

Voltage Detector IC Series

CMOS Over Voltage Detector IC

BD71L4L-1series

General Descriptions

ROHM's BD71L4L-1series is highly accurate and low current Over Voltage Detector IC. It is an N-Channel Open-Drain output type with detection voltage of 4.05V and hysteresis voltage of 30mV. It is most suitable for monitoring the charge of a lithium-ion battery.

Features

- High Accuracy Detection Voltage
- Low Current Consumption
- N-Channel Open Drain Output
- Wide Operating Temperature Range
- Very Small and Low Height Package
- Package SSOP5 is similar to SOT-23-5 (JEDEC)

Key Specifications

- Detection Voltage: 4.05V (Typ.)
- High Accuracy Detection Voltage: ±0.8%
- Ultra-Low Current Consumption: 0.8μA (Typ.)
- Operating Temperature Range: -40°C to +85°C

Package

- SSOP5: 2.90mm x 2.80mm x 1.25mm
- HVSO5: 1.60mm x 1.60mm x 0.60mm



Applications

- All electronics equipment with lithium-ion battery
- All electronics equipment that needs over-voltage protection

Typical Application Circuit

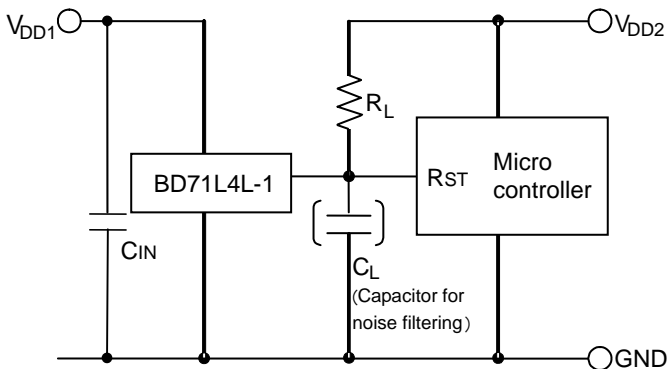

Connection Diagram

SSOP5

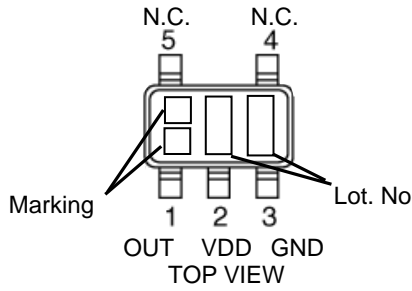

HVSOF5

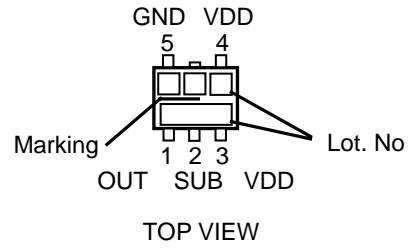

Pin Descriptions

SSOP5		
PIN No.	Symbol	Function
1	OUT	Reset Output
2	VDD	Power Supply Voltage
3	GND	GND
4	N.C.	Unconnected Terminal
5	N.C.	Unconnected Terminal

HVSOF5		
PIN No.	Symbol	Function
1	OUT	Reset Output
2	SUB *	Substrate
3	VDD *	Power Supply Voltage
4	VDD *	Power Supply Voltage
5	GND	GND

* The SUB pin(2pin) and the VDD pins(3pin, 4pin) must be wired together.

Ordering Information

B D x x x x x x - 1 T R

Part Number	Function 71 : Over Voltage Detector	Output logic L : Active Low	Detection Voltage Value 4L : 4.05V	Package G : SSOP5 HFV : HVSOF5	Packaging and forming specification Embossed tape and reel TR : The pin number 1 is the upper right : SSOP5 : HVSOF5
-------------	--	--------------------------------	---------------------------------------	--------------------------------------	--

Absolute Maximum Ratings

Parameter		Symbol	Limits	Unit
Power Supply Voltage		VDD-GND	-0.3 to +7	V
Output Voltage	N-Channel Open Drain Output	VOUT	GND-0.3 to +7	V
Output Current		Io	70	mA
Power Dissipation	SSOP5 *1*3	Pd	0.540	W
	HVSOF5 *2*3		0.530	
Operating Temperature		Topr	-40 to +85	°C
Ambient Storage Temperature		Tstg	-55 to +125	°C

*1 Reduced by 0.0054W/°C when used over 25°C.

*2 Reduced by 0.0053W/°C when used over 25°C.

*3 When mounted on ROHM standard circuit board (70mm×70mm×1.6mm, glass epoxy board).

Caution: Operating the IC over the absolute maximum ratings may damage the IC. The damage can either be a short circuit between pins or an open circuit between pins and the internal circuitry. Therefore, it is important to consider circuit protection measures, such as adding a fuse, in case the IC is operated over the absolute maximum ratings.

Electrical Characteristics (Unless Otherwise Specified, Ta=0°C to 60°C, VDD=1.2V to 6.0V)

Parameter	Symbol	Conditions	Limit			Unit	
			Min	Typ	Max		
Detection Voltage	VDET	RL=470kΩ VDD=L→H	Ta=25°C	4.034	4.05	4.066	V
			Ta =0°C to 60°C	4.018	-	4.083	
Hysteresis Voltage	ΔVDET	VDD=L→H→L, RL=470kΩ	-	30	40	mV	
Output Delay Time "L→H"	TPLH	RL=100kΩ, CL=100pF *4 Vout = GND→50%	-	-	100	μs	
Output Delay Time "H→L"	TPHL	RL=100kΩ, CL=100pF *5 Vout = VDD→50%	-	-	100	μs	
Supply Current 1	IDD1	VDD= VDET + 0.2V	-	0.60	2.40	μA	
Supply Current 2	IDD2	VDD= VDET - 0.2V	-	0.70	2.80	μA	
Operating Voltage Range	VOPL	VOUT ≥ 0.8V, RL=470kΩ	1.20	-	-	V	
'Low' Output Voltage(Nch)	VOL	VDD= VDET+0.2 V, ISINK=4.0mA	-	-	0.3	V	
Output Leak Current	Ileak	VDD=VDS=3.8V	-	-	1.0	uA	

VDET : Standard Detection Voltage(4.05V)

RL : Pull-up Resistor between VOUT and VDD.

CL : Capacitor to be connected between VOUT and GND.

Designed Guarantee.(Outgoing inspection is not done on all products.)

*4 TPLH: VDD = (VDET typ. + 0.5V) to (VDET typ. - 0.5V)

*5 TPHL: VDD = (VDET typ - 0.5V) to (VDET typ.+ 0.5V)

Block Diagram

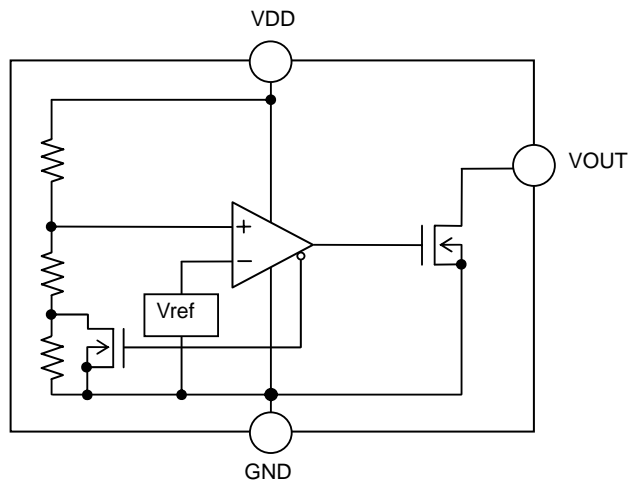

Figure 1. BD71L4L-1

Typical Performance Curves

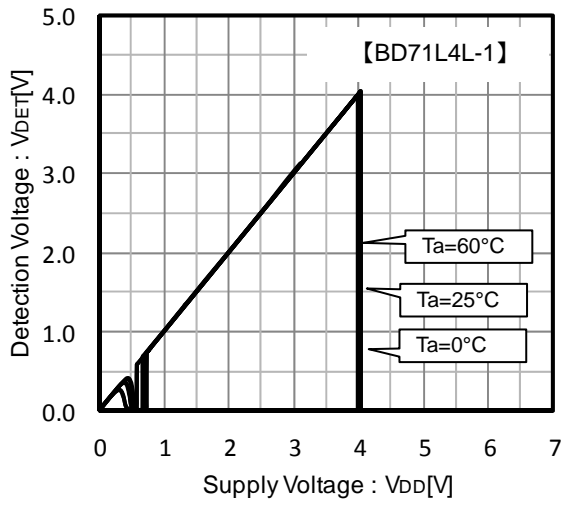

Figure 2. Detection Voltage

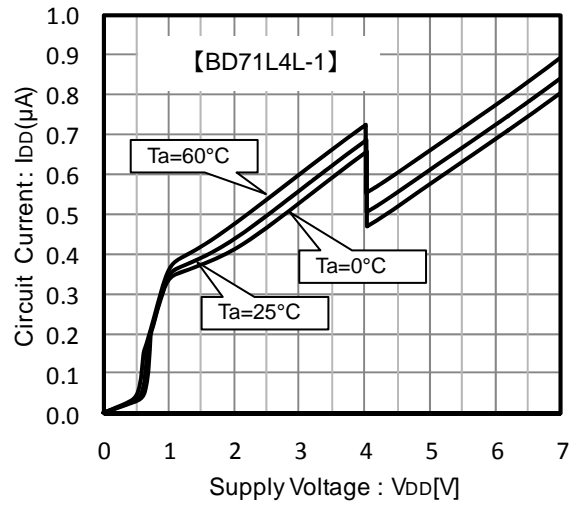

Figure 3. Circuit Current

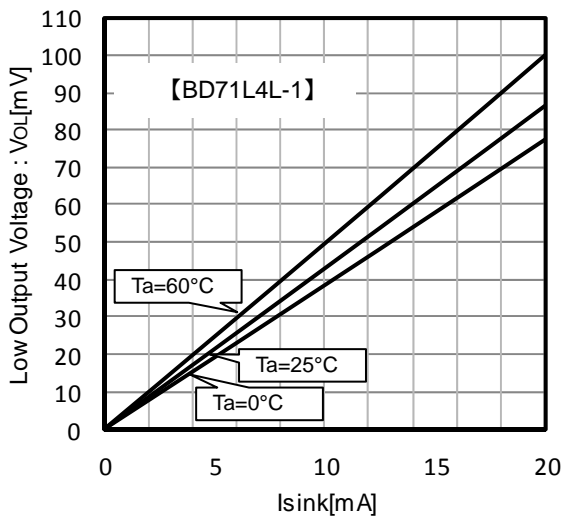

Figure 4. Low Output Voltage

V_{DD}=4.0V

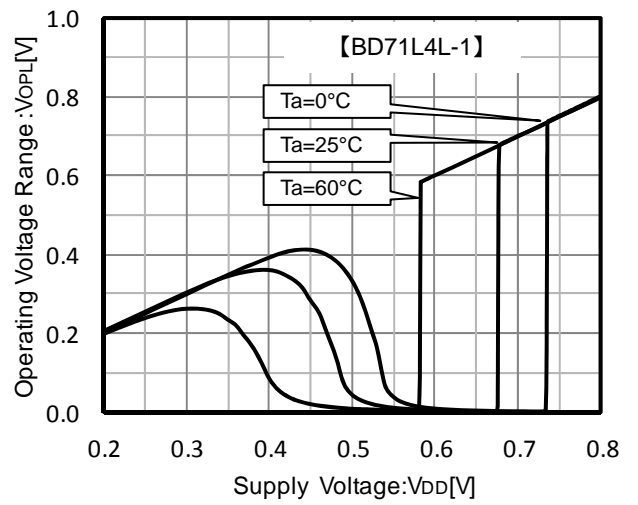

Figure 5. Operating Voltage Range

Typical Performance Curves – continued

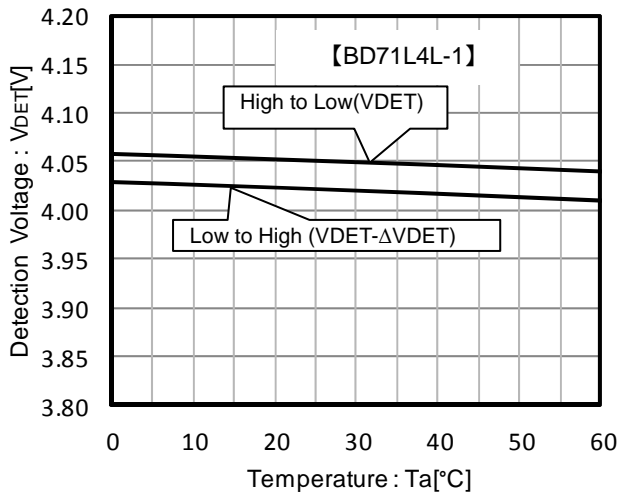

Figure 6. Detection Voltage vs. Temperature

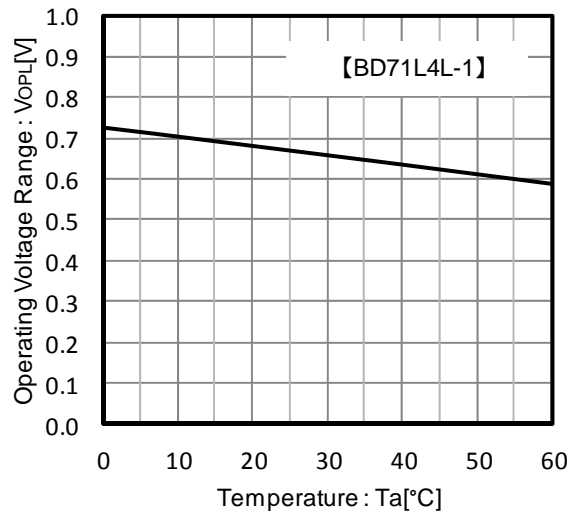

Figure 7. Operating Voltage Range vs. Temperature

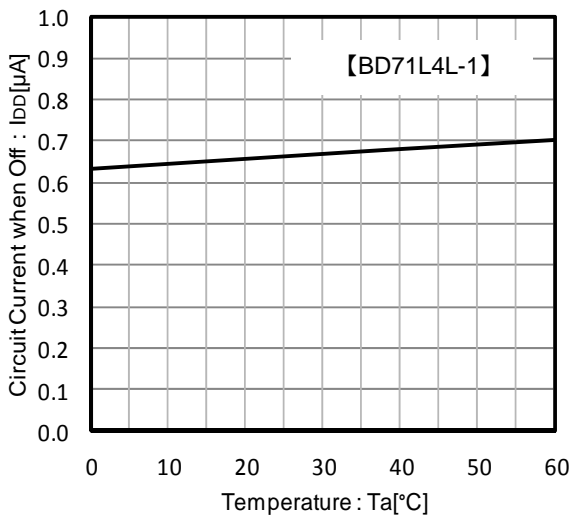

Figure 8. Supply Current 1 vs. Temperature

VDD=VDET-0.2V
VDD=3.85V

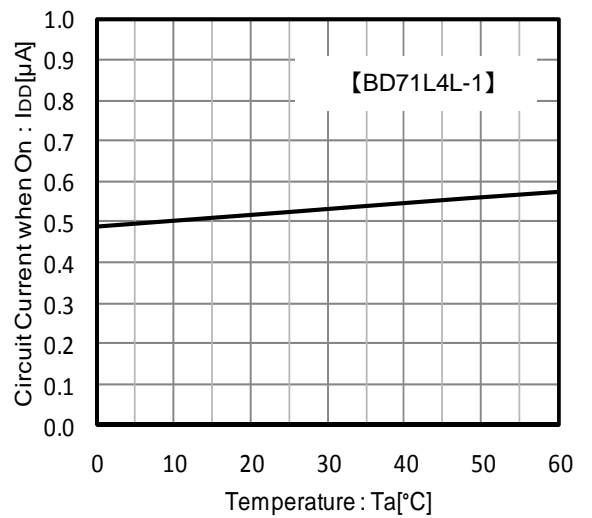

Figure 9. Supply Current 2 vs. Temperature

VDD=VDET+0.2V
VDD=4.25V

Typical Performance Curves – continued

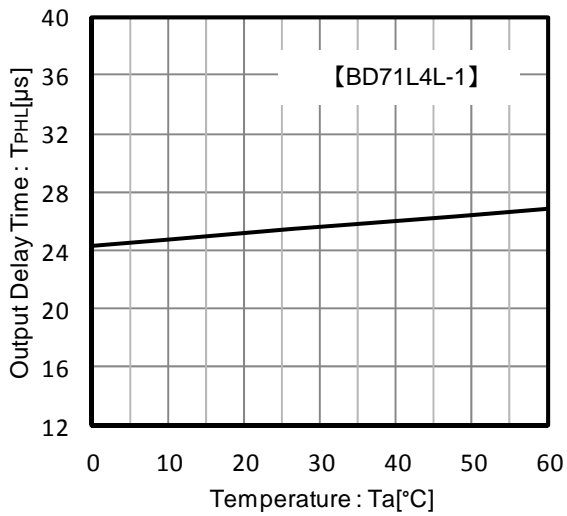

Figure 10. Output Delay Time (T_{PHL})
 V_{DD}=V_{DET}-0.5V to V_{DET}+0.5V
 V_{DD}=3.55V to 4.55V

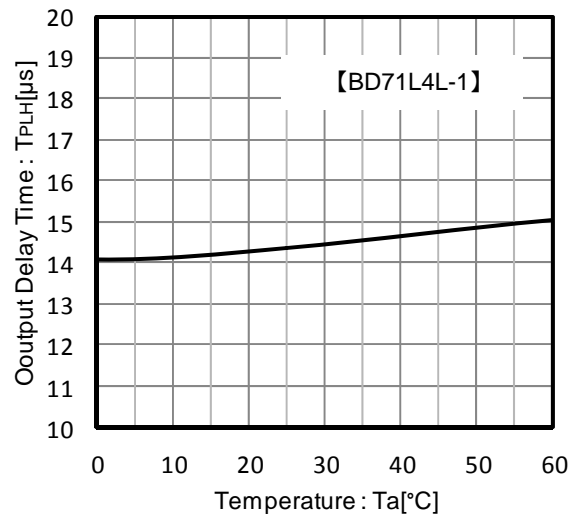

Figure 11. Output Delay Time(T_{PLH})
 V_{DD}=V_{DET}+0.5V to V_{DET}-0.5V
 V_{DD}=4.55V to 3.55V

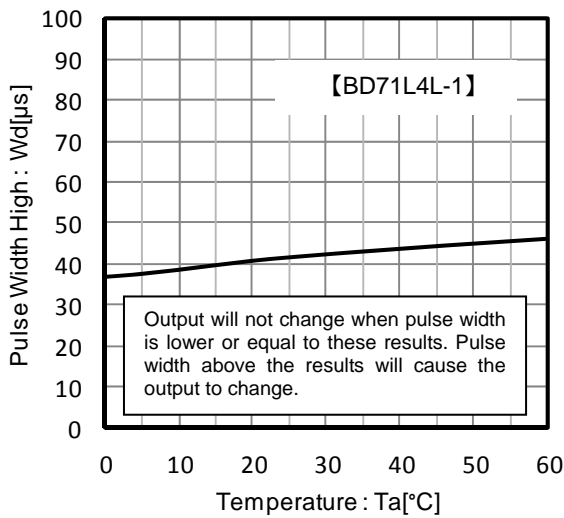

Figure 12. Pulse Width vs. Voltage Level
 V_{DD-LOW}=1.2V, V_{DD-HIGH}=4.2V, C_{IN}=0.1μF

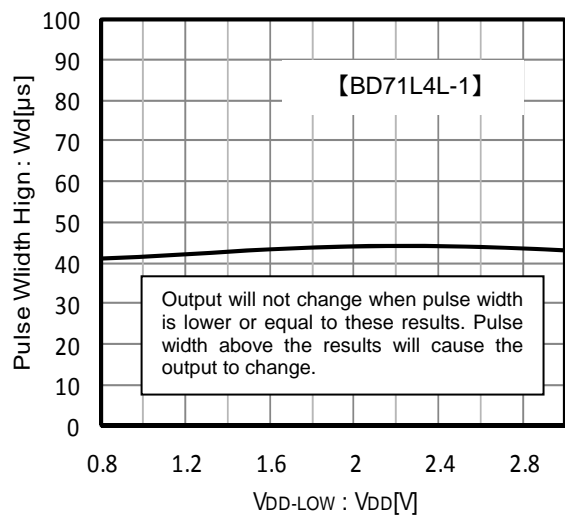

Figure 13. Pulse Width vs. Voltage Level
 V_{DD-HIGH}=4.2V, C_{IN}=0.1μF, Ta=25°C

Application Information

Explanation of Operation

The detection and release voltages are used as threshold voltages. When the voltage applied to the VDD pins reaches the appropriate threshold voltage, the OUT terminal voltage switches from either “High” to “Low” or from “Low” to “High”. Please refer to the Timing Waveform and Electrical Characteristics for information on hysteresis.

Because the BD71L4L-1 uses an open drain output type, it is necessary to connect a pull-up resistor to VDD or another power supply if needed [The output “High” voltage (VOUT) in this case becomes VDD or the voltage of the other power supply].

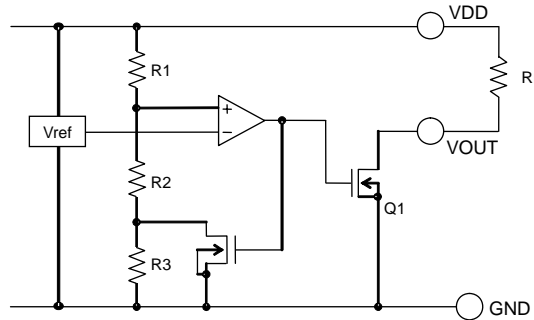

Figure 14. Internal Block Diagram

Timing Waveform

Example: the following shows the relationship between the input voltages (VDD) and the output voltage (VOUT) when the input power supply voltage (VDD) swept up and down (the circuits are those in Figure .14).

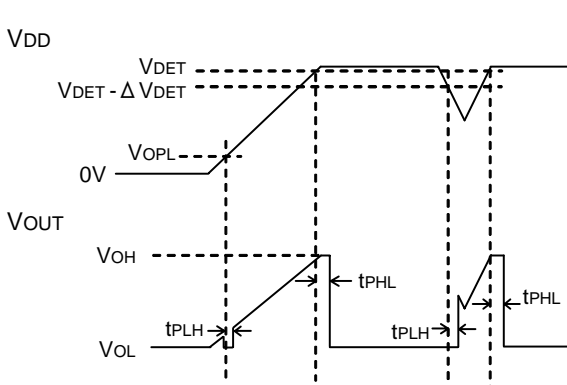

Figure 15. Timing Waveform

- ① When the power supply is turned on, the output is unstable from after over the operating limit voltage (VOPL) until TPLH. Therefore it is possible that the reset signal is not outputted when the rise time of VDD is faster than TPLH.
- ② When VDD is greater than VOPL but less than the reset detection voltage (VDET), the output voltages will switch to High.
- ③ If VDD exceeds the reset detection voltage (VDET), then VOUT switches from H to L.
- ④ If VDD drops below the release voltage (VDET+ΔVDET) when the power supply is powered down or when there is a power supply fluctuation, VOUT switches to H (with a delay of TPLH).
- ⑤ The potential difference between the detection voltage and the release voltage is known as the hysteresis width (ΔVDET).

Circuit Applications

1) Examples of a common power supply detection reset circuit.

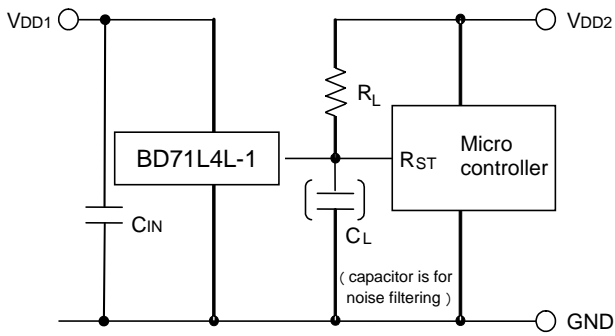

Figure 16. Open Drain Output Type

CASE1: Power supply of the microcontroller (VDD2) differs from the power supply of the reset detection IC (VDD1).

Use an open drain output type device with a load resistance R_L attached as shown in Figure 16.

CASE2: Power supply of the microcontroller (VDD1) is same as the power supply of the reset detection IC (VDD1).

Use an open drain device with a pull up resistor between output and VDD1.

This IC's hysteresis between detection voltage and release voltage is 30mV(typ), so when the VOUT logic changes a chattering occur.

C_{IN} value needs more than 0.1uF to eliminate this.

When a capacitance C_L for noise filtering is connected to the OUT pin (the reset signal input terminal of the microcontroller), please take into account the rise and fall waveform of the output voltage (VOUT).

The Electrical characteristics were measured using $R_L = 470k\Omega$ and $C_L = 100pF$.

2) The following is an example of a circuit application in which an OR connection between two types of detection voltage resets the microcontroller.

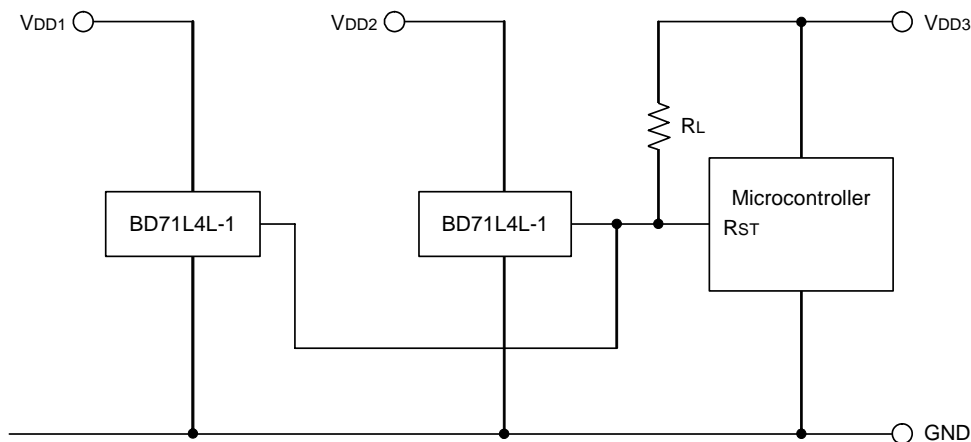

Figure 17

To reset the microcontroller when many independent power supplies are used in the system, OR connect to the microcontroller's input with pull-up resistor to the supply voltage of the microcontroller (VDD3) as shown in Figure 17. By pulling-up to VDD3, output "High" voltage of micro-controller power supply is possible.

3) Examples of the power supply with resistor dividers

In applications wherein the power supply voltage of an IC comes from a resistor divider circuit, an in-rush current will flow into the circuit when the output level switches from “High” to “Low” or vice versa. In-rush current is a sudden surge of current that flows from the power supply (VDD) to ground (GND) as the output logic changes its state. This current flow may cause malfunction in the systems operation such as output oscillations, etc.

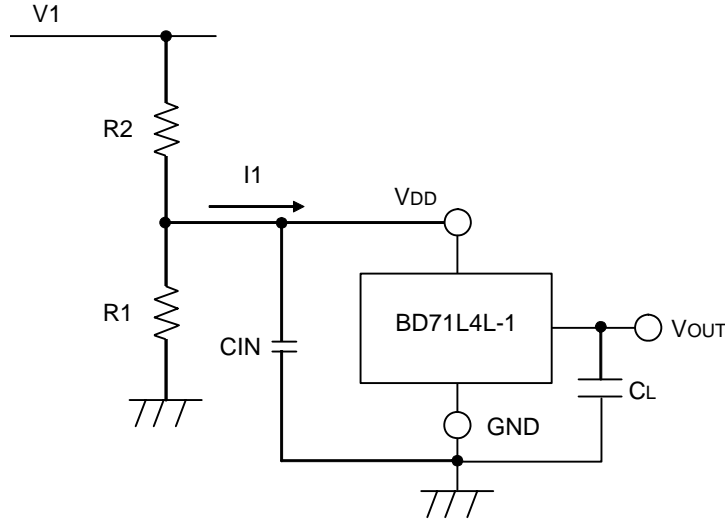

Figure 18

When an in-rush current (I1) flows into the circuit (Refer to Figure 18.) at the time when output switches from “Low” to “High”, a voltage drop of $I1 \times R2$ (input resistor) will occur in the circuit causing the VDD supply voltage to decrease. When the VDD voltage drops below the detection voltage, the output will switch from “High” to “Low”. While the output voltage is at “Low” condition, in-rush current will stop flowing and the voltage drop will be reduced. As a result, the output voltage will switch again from “Low” to “High” which causes an in-rush current and a voltage drop. This operation repeats and will result to oscillation.

It is same when only the R2 used.

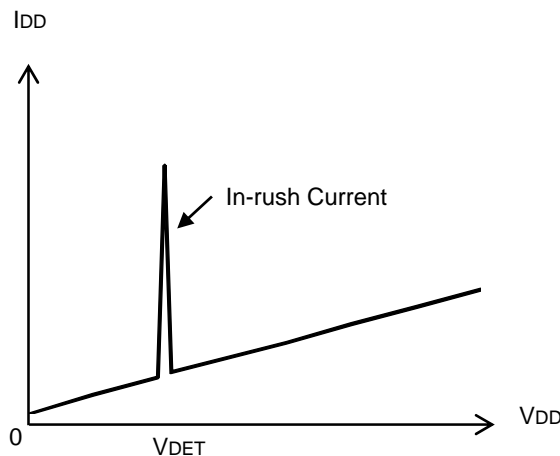

Figure 19. Current Consumption vs. Power Supply Voltage

Operational Notes

1. Reverse Connection of Power Supply

Connecting the power supply in reverse polarity can damage the IC. Take precautions against reverse polarity when connecting the power supply, such as mounting an external diode between the power supply and the IC's power supply terminals.

2. Power Supply Lines

Design the PCB layout pattern to provide low impedance ground and supply lines. Separate the ground and supply lines of the digital and analog blocks to prevent noise in the ground and supply lines of the digital block from affecting the analog block. Furthermore, connect a capacitor to ground at all power supply pins. Consider the effect of temperature and aging on the capacitance value when using electrolytic capacitors.

3. Ground Voltage

Ensure that no pins are at a voltage below that of the ground pin at any time, even during transient condition.

4. Ground Wiring Pattern

When using both small-signal and large-current GND traces, the two ground traces should be routed separately but connected to a single ground at the reference point of the application board to avoid fluctuations in the small-signal ground caused by large currents. Also ensure that the GND traces of external components do not cause variations on the GND voltage. The power supply and ground lines must be as short and thick as possible to reduce line impedance.

5. Thermal Consideration

Should by any chance the power dissipation rating be exceeded, the rise in temperature of the chip may result in deterioration of the properties of the chip. The absolute maximum rating of the Pd stated in this specification is when the IC is mounted on a 70mm x 70mm x 1.6mm glass epoxy board. In case of exceeding this absolute maximum rating, increase the board size and copper area to prevent exceeding the Pd rating.

6. Recommended Operating Conditions

These conditions represent a range within which the expected characteristics of the IC can be approximately obtained. The electrical characteristics are guaranteed under the conditions of each parameter.

7. Rush Current

When power is first supplied to the IC, it is possible that the internal logic may be unstable and inrush current may flow instantaneously due to the internal powering sequence and delays, especially if the IC has more than one power supply. Therefore, give special consideration to power coupling capacitance, power wiring, width of GND wiring, and routing of connections.

8. Operation Under Strong Electromagnetic Field

Operating the IC in the presence of a strong electromagnetic field may cause the IC to malfunction.

9. Testing on Application Boards

When testing the IC on an application board, connecting a capacitor directly to a low-impedance output pin may subject the IC to stress. Always discharge capacitors completely after each process or step. The IC's power supply should always be turned off completely before connecting or removing it from the test setup during the inspection process. To prevent damage from static discharge, ground the IC during assembly and use similar precautions during transport and storage.

10. Inter-pin Short and Mounting Errors

Ensure that the direction and position are correct when mounting the IC on the PCB. Incorrect mounting may result in damaging the IC. Avoid nearby pins being shorted to each other especially to ground. Inter-pin shorts could be due to many reasons such as metal particles, water droplets (in very humid environment) and unintentional solder bridge deposited in between pins during assembly to name a few.

11. Unused Input Terminals

Input terminals of an IC are often connected to the gate of a MOS transistor. The gate has extremely high impedance and extremely low capacitance. If left unconnected, the electric field from the outside can easily charge it. The small charge acquired in this way is enough to produce a significant effect on the conduction through the transistor and cause unexpected operation of the IC. So unless otherwise specified, unused input terminals should be connected to the power supply or ground line.

12. Regarding Input Pins of the IC

In the construction of this IC, P-N junctions are inevitably formed creating parasitic diodes or transistors. The operation of these parasitic elements can result in mutual interference among circuits, operational faults, or physical damage. Therefore, conditions which cause these parasitic elements to operate, such as applying a voltage to an input pin lower than the GND voltage should be avoided. Furthermore, do not apply a voltage to the input terminals when no power supply voltage is applied to the IC. Even if the power supply voltage is applied, make sure that the input terminals have voltages within the values specified in the electrical characteristics of this IC

13. Ceramic Capacitor

When using a ceramic capacitor, determine the dielectric constant considering the change of capacitance with temperature and the decrease in nominal capacitance due to DC bias and others.

14. Bypass Capacitor for Noise Rejection

To help reject noise, put a 1 μ F capacitor between VDD pin and GND and 1000pF capacitor between VOUT pin and GND. Be careful when using extremely big capacitor as transient response will be affected.

15. The VDD line impedance might cause oscillation because of the detection current.

16. A VDD to GND capacitor (as close connection as possible) should be used in high VDD line impedance condition.

17. Lower than the minimum input voltage puts the VOUT in high impedance state, and it must be VDD in pull up (VDD) condition.

18. External Parameters

The recommended parameter range for R_L is 10k Ω to 1M Ω . There are many factors (board layout, etc) that can affect characteristics. Please verify and confirm using practical applications.

19. Power-on Reset Operation

Please note that the power on reset output varies with the VDD rise time. Please verify the behavior in the actual operation.

20. This IC has extremely high impedance terminals. Small leak current due to the uncleanness of PCB surface might cause unexpected operations. Application values in these conditions should be selected carefully. If the leakage is assumed between the VOUT terminal and the GND terminal, the pull up resistor should be less than 1/10 of the assumed leak resistance.

Physical Dimension, Tape and Reel Information

Package Name	SSOP5
--------------	-------

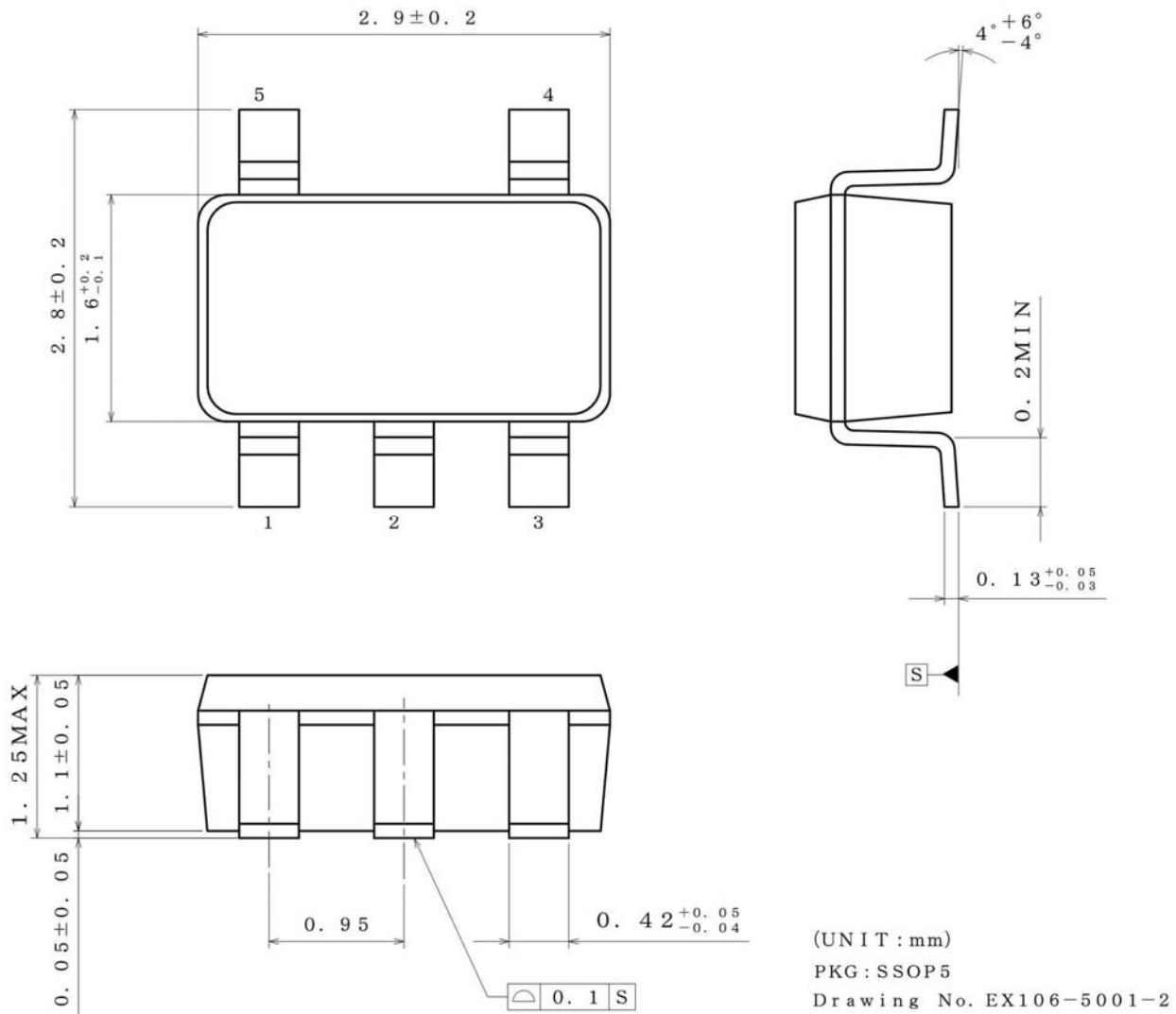

< Tape and Reel Information >

Tape	Embossed carrier tape
Quantity	3000pcs
Direction of feed	TR (The direction is the 1pin of product is at the upper right when you hold) reel on the left hand and you pull out the tape on the right hand

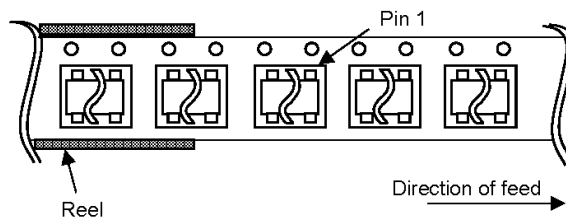

Package Name	HVSOF5
--------------	--------

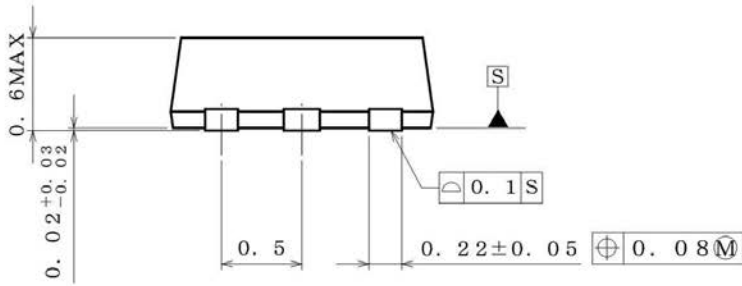
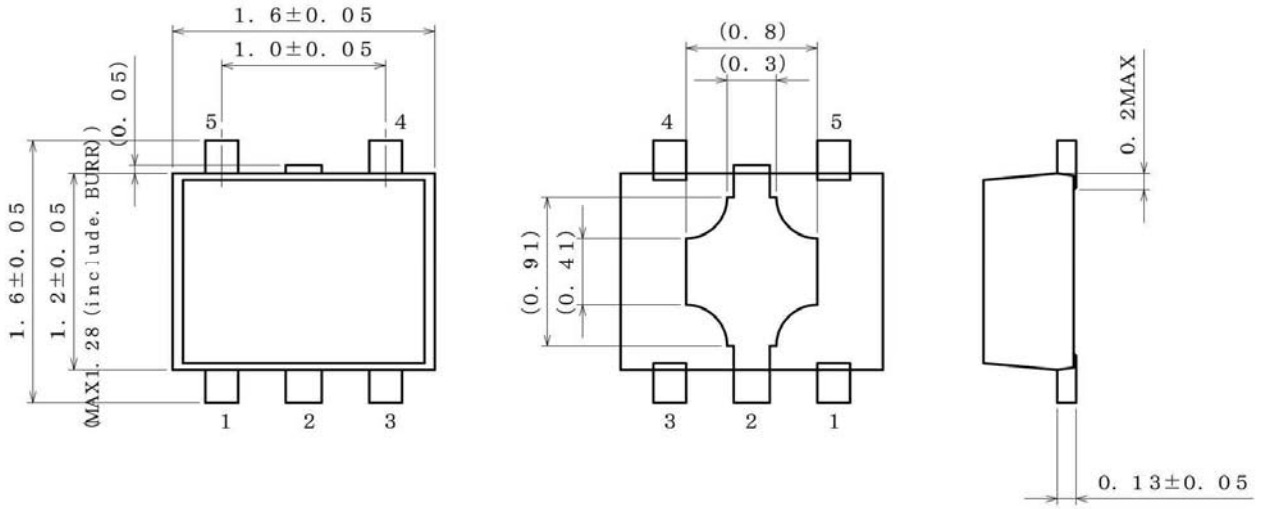

(UNIT : mm)
 PKG : HVSOF5
 Drawing No. EX108-5002

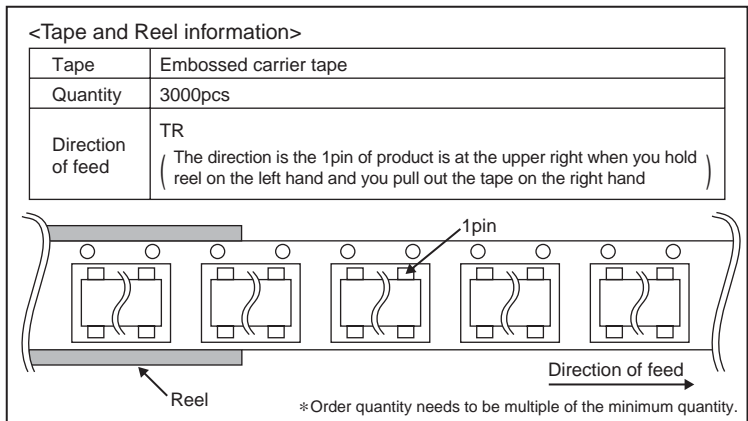

Revision History

Date	Revision	Changes
20.May.2013	001	New Release
24.July.2013	002	Modify the general description and applications on page 1 Changed VDET spec on pages 1 ~ 3 Changed IDD1 and IDD2 spec on page 3 Changed I _{leak} condition on page 3
24.Oct.2013	003	Add 1 packages as following:HVSO5
31.Jan.2014	004	Modify the package on page 1 and the connection diagram on page 2 Add note of HVSO5 on page 2

Notice

Precaution on using ROHM Products

- Our Products are designed and manufactured for application in ordinary electronic equipments (such as AV equipment, OA equipment, telecommunication equipment, home electronic appliances, amusement equipment, etc.). If you intend to use our Products in devices requiring extremely high reliability (such as medical equipment ^(Note 1), transport equipment, traffic equipment, aircraft/spacecraft, nuclear power controllers, fuel controllers, car equipment including car accessories, safety devices, etc.) and whose malfunction or failure may cause loss of human life, bodily injury or serious damage to property ("Specific Applications"), please consult with the ROHM sales representative in advance. Unless otherwise agreed in writing by ROHM in advance, ROHM shall not be in any way responsible or liable for any damages, expenses or losses incurred by you or third parties arising from the use of any ROHM's Products for Specific Applications.

(Note1) Medical Equipment Classification of the Specific Applications

JAPAN	USA	EU	CHINA
CLASS III	CLASS III	CLASS II b	CLASS III
CLASS IV		CLASS III	

- ROHM designs and manufactures its Products subject to strict quality control system. However, semiconductor products can fail or malfunction at a certain rate. Please be sure to implement, at your own responsibilities, adequate safety measures including but not limited to fail-safe design against the physical injury, damage to any property, which a failure or malfunction of our Products may cause. The following are examples of safety measures:
 - Installation of protection circuits or other protective devices to improve system safety
 - Installation of redundant circuits to reduce the impact of single or multiple circuit failure
- Our Products are designed and manufactured for use under standard conditions and not under any special or extraordinary environments or conditions, as exemplified below. Accordingly, ROHM shall not be in any way responsible or liable for any damages, expenses or losses arising from the use of any ROHM's Products under any special or extraordinary environments or conditions. If you intend to use our Products under any special or extraordinary environments or conditions (as exemplified below), your independent verification and confirmation of product performance, reliability, etc. prior to use, must be necessary:
 - Use of our Products in any types of liquid, including water, oils, chemicals, and organic solvents
 - Use of our Products outdoors or in places where the Products are exposed to direct sunlight or dust
 - Use of our Products in places where the Products are exposed to sea wind or corrosive gases, including Cl₂, H₂S, NH₃, SO₂, and NO₂
 - Use of our Products in places where the Products are exposed to static electricity or electromagnetic waves
 - Use of our Products in proximity to heat-producing components, plastic cords, or other flammable items
 - Sealing or coating our Products with resin or other coating materials
 - Use of our Products without cleaning residue of flux (even if you use no-clean type fluxes, cleaning residue of flux is recommended); or Washing our Products by using water or water-soluble cleaning agents for cleaning residue after soldering
 - Use of the Products in places subject to dew condensation
- The Products are not subject to radiation-proof design.
- Please verify and confirm characteristics of the final or mounted products in using the Products.
- In particular, if a transient load (a large amount of load applied in a short period of time, such as pulse. is applied, confirmation of performance characteristics after on-board mounting is strongly recommended. Avoid applying power exceeding normal rated power; exceeding the power rating under steady-state loading condition may negatively affect product performance and reliability.
- De-rate Power Dissipation (Pd) depending on Ambient temperature (Ta). When used in sealed area, confirm the actual ambient temperature.
- Confirm that operation temperature is within the specified range described in the product specification.
- ROHM shall not be in any way responsible or liable for failure induced under deviant condition from what is defined in this document.

Precaution for Mounting / Circuit board design

- When a highly active halogenous (chlorine, bromine, etc.) flux is used, the residue of flux may negatively affect product performance and reliability.
- In principle, the reflow soldering method must be used; if flow soldering method is preferred, please consult with the ROHM representative in advance.

For details, please refer to ROHM Mounting specification

Precautions Regarding Application Examples and External Circuits

1. If change is made to the constant of an external circuit, please allow a sufficient margin considering variations of the characteristics of the Products and external components, including transient characteristics, as well as static characteristics.
2. You agree that application notes, reference designs, and associated data and information contained in this document are presented only as guidance for Products use. Therefore, in case you use such information, you are solely responsible for it and you must exercise your own independent verification and judgment in the use of such information contained in this document. ROHM shall not be in any way responsible or liable for any damages, expenses or losses incurred by you or third parties arising from the use of such information.

Precaution for Electrostatic

This Product is electrostatic sensitive product, which may be damaged due to electrostatic discharge. Please take proper caution in your manufacturing process and storage so that voltage exceeding the Products maximum rating will not be applied to Products. Please take special care under dry condition (e.g. Grounding of human body / equipment / solder iron, isolation from charged objects, setting of ionizer, friction prevention and temperature / humidity control).

Precaution for Storage / Transportation

1. Product performance and soldered connections may deteriorate if the Products are stored in the places where:
 - [a] the Products are exposed to sea winds or corrosive gases, including Cl₂, H₂S, NH₃, SO₂, and NO₂
 - [b] the temperature or humidity exceeds those recommended by ROHM
 - [c] the Products are exposed to direct sunshine or condensation
 - [d] the Products are exposed to high Electrostatic
2. Even under ROHM recommended storage condition, solderability of products out of recommended storage time period may be degraded. It is strongly recommended to confirm solderability before using Products of which storage time is exceeding the recommended storage time period.
3. Store / transport cartons in the correct direction, which is indicated on a carton with a symbol. Otherwise bent leads may occur due to excessive stress applied when dropping of a carton.
4. Use Products within the specified time after opening a humidity barrier bag. Baking is required before using Products of which storage time is exceeding the recommended storage time period.

Precaution for Product Label

QR code printed on ROHM Products label is for ROHM's internal use only.

Precaution for Disposition

When disposing Products please dispose them properly using an authorized industry waste company.

Precaution for Foreign Exchange and Foreign Trade act

Since our Products might fall under controlled goods prescribed by the applicable foreign exchange and foreign trade act, please consult with ROHM representative in case of export.

Precaution Regarding Intellectual Property Rights

1. All information and data including but not limited to application example contained in this document is for reference only. ROHM does not warrant that foregoing information or data will not infringe any intellectual property rights or any other rights of any third party regarding such information or data. ROHM shall not be in any way responsible or liable for infringement of any intellectual property rights or other damages arising from use of such information or data.:
2. No license, expressly or implied, is granted hereby under any intellectual property rights or other rights of ROHM or any third parties with respect to the information contained in this document.

Other Precaution

1. This document may not be reprinted or reproduced, in whole or in part, without prior written consent of ROHM.
2. The Products may not be disassembled, converted, modified, reproduced or otherwise changed without prior written consent of ROHM.
3. In no event shall you use in any way whatsoever the Products and the related technical information contained in the Products or this document for any military purposes, including but not limited to, the development of mass-destruction weapons.
4. The proper names of companies or products described in this document are trademarks or registered trademarks of ROHM, its affiliated companies or third parties.

General Precaution

1. Before you use our Products, you are requested to carefully read this document and fully understand its contents. ROHM shall not be in any way responsible or liable for failure, malfunction or accident arising from the use of any ROHM's Products against warning, caution or note contained in this document.
2. All information contained in this document is current as of the issuing date and subject to change without any prior notice. Before purchasing or using ROHM's Products, please confirm the latest information with a ROHM sales representative.
3. The information contained in this document is provided on an "as is" basis and ROHM does not warrant that all information contained in this document is accurate and/or error-free. ROHM shall not be in any way responsible or liable for any damages, expenses or losses incurred by you or third parties resulting from inaccuracy or errors of or concerning such information.

Компания «Life Electronics» занимается поставками электронных компонентов импортного и отечественного производства от производителей и со складов крупных дистрибьюторов Европы, Америки и Азии.

С конца 2013 года компания активно расширяет линейку поставок компонентов по направлению коаксиальный кабель, кварцевые генераторы и конденсаторы (керамические, пленочные, электролитические), за счёт заключения дистрибьюторских договоров

Мы предлагаем:

- Конкурентоспособные цены и скидки постоянным клиентам.
- Специальные условия для постоянных клиентов.
- Подбор аналогов.
- Поставку компонентов в любых объемах, удовлетворяющих вашим потребностям.
- Приемлемые сроки поставки, возможна ускоренная поставка.
- Доставку товара в любую точку России и стран СНГ.
- Комплексную поставку.
- Работу по проектам и поставку образцов.
- Формирование склада под заказчика.
- Сертификаты соответствия на поставляемую продукцию (по желанию клиента).
- Тестирование поставляемой продукции.
- Поставку компонентов, требующих военную и космическую приемку.
- Входной контроль качества.
- Наличие сертификата ISO.

В составе нашей компании организован Конструкторский отдел, призванный помогать разработчикам, и инженерам.

Конструкторский отдел помогает осуществить:

- Регистрацию проекта у производителя компонентов.
- Техническую поддержку проекта.
- Защиту от снятия компонента с производства.
- Оценку стоимости проекта по компонентам.
- Изготовление тестовой платы монтаж и пусконаладочные работы.



Тел: +7 (812) 336 43 04 (многоканальный)

Email: org@lifeelectronics.ru