

# NLAS5223C, NLAS5223CL

## Ultra-Low 0.35 $\Omega$ Dual SPDT Analog Switch

The NLAS5223C is an advanced CMOS analog switch fabricated in Sub-micron silicon gate CMOS technology. The device is a dual Independent Single Pole Double Throw (SPDT) switch featuring Ultra-Low  $R_{ON}$  of 0.35  $\Omega$ , at  $V_{CC} = 4.3$  V.

The part also features guaranteed Break Before Make (BBM) switching, assuring the switches never short the driver.

### Features

- Ultra-Low  $R_{ON}$ , 0.35  $\Omega$  (typ) at  $V_{CC} = 4.3$  V
- NLAS5223C Interfaces with 2.8 V Chipset
- NLAS5223CL Interfaces with 1.8 V Chipset
- Single Supply Operation from 1.65–4.5 V
- Full 0– $V_{CC}$  Signal Handling Capability
- High Off-Channel Isolation
- Low Standby Current, < 50 nA
- Low Distortion
- $R_{ON}$  Flatness of 0.15  $\Omega$
- High Continuous Current Capability
  - ◆  $\pm 320$  mA Through Each Switch
- Large Current Clamping Diodes at Analog Inputs
  - ◆  $\pm 320$  mA Continuous Current Capability
- Package:
  - ◆ 1.4 x 1.8 x 0.55 mm UQFN10 Pb-Free
- These are Pb-Free Devices

### Applications

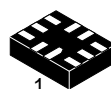
- Cell Phone Audio Block
- Speaker and Earphone Switching
- Ring-Tone Chip/Amplifier Switching
- Modems



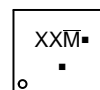
ON Semiconductor®

<http://onsemi.com>

### MARKING DIAGRAM

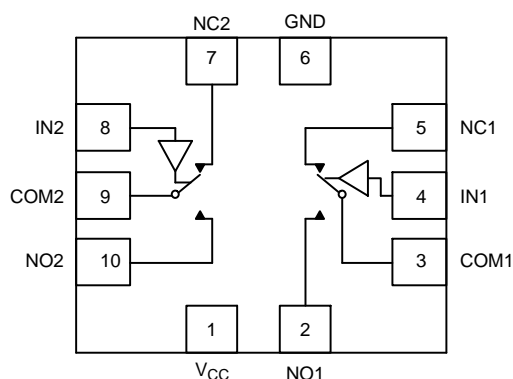


UQFN10  
CASE 488AT



XX = Specific Device Code  
M = Date Code/Assembly Location  
▪ = Pb-Free Device

(Note: Microdot may be in either location)



### FUNCTION TABLE

IN 1, 2	NO 1, 2	NC 1, 2
0	OFF	ON
1	ON	OFF

### ORDERING INFORMATION

See detailed ordering, marking and shipping information in the package dimensions section on page 9 of this data sheet.

# NLAS5223C, NLAS5223CL

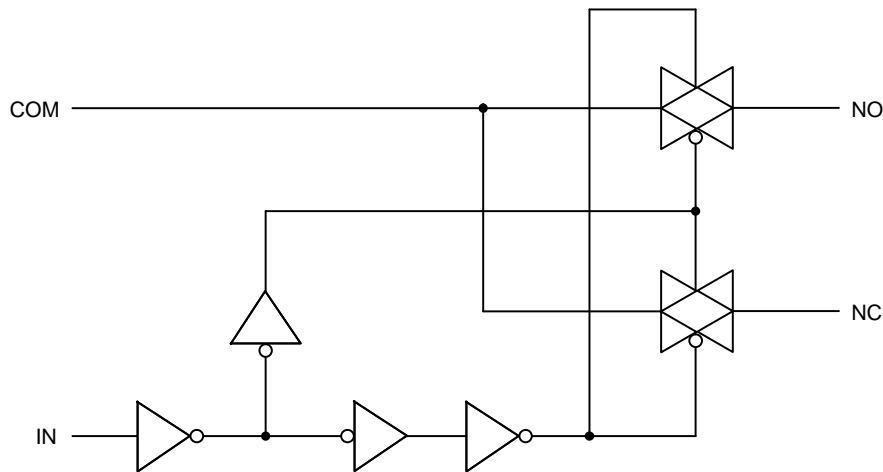


Figure 1. Logic Equivalent Circuit

## PIN DESCRIPTION

QFN PIN #	Symbol	Name and Function
2, 5, 7, 10	NC1 to NC2, NO1 to NO2	Independent Channels
4, 8	IN1 and IN2	Controls
3, 9	COM1 and COM2	Common Channels
6	GND	Ground (V)
1	V <sub>CC</sub>	Positive Supply Voltage

## MAXIMUM RATINGS

Symbol	Parameter	Value	Unit
V <sub>CC</sub>	Positive DC Supply Voltage	-0.5 to +7.0	V
V <sub>IS</sub>	Analog Input Voltage (V <sub>NO</sub> , V <sub>NC</sub> , or V <sub>COM</sub> )	-0.5 ≤ V <sub>IS</sub> ≤ V <sub>CC</sub> + 0.5	V
V <sub>IN</sub>	Digital Select Input Voltage	-0.5 ≤ V <sub>IN</sub> ≤ +5.5	V
I <sub>anI1</sub>	Continuous DC Current from COM to NC/NO	±320	mA
I <sub>anI-pk1</sub>	Peak Current from COM to NC/NO, 10% Duty Cycle, 100 ms = t <sub>ON</sub> (Note 1)	±600	mA
I <sub>anI-pk2</sub>	Instantaneous Peak Current from COM to NC/NO, 10% Duty Cycle, t <sub>ON</sub> < 1 μs	±850	mA
I <sub>clmp</sub>	Continuous DC Current into COM/NO/NC with Respect to V <sub>CC</sub> or GND	±100	mA
ESD	ESD Withstand Voltage Human Body Model (HBM)	>3000	V

Stresses exceeding Maximum Ratings may damage the device. Maximum Ratings are stress ratings only. Functional operation above the Recommended Operating Conditions is not implied. Extended exposure to stresses above the Recommended Operating Conditions may affect device reliability.

1. Defined as 10% ON, 90% OFF Duty Cycle.

## RECOMMENDED OPERATING CONDITIONS

Symbol	Parameter	Min	Max	Unit
V <sub>CC</sub>	DC Supply Voltage	1.65	4.5	V
V <sub>IN</sub>	Digital Select Input Voltage (OVT) Overvoltage Tolerance	GND	4.5	V
V <sub>IS</sub>	Analog Input Voltage (NC, NO, COM)	GND	V <sub>CC</sub>	V
T <sub>A</sub>	Operating Temperature Range	-40	+85	°C
t <sub>r</sub> , t <sub>f</sub>	Input Rise or Fall Time, SELECT V <sub>CC</sub> = 1.6 V – 2.7 V V <sub>CC</sub> = 3.0 V – 4.5 V		20 10	ns/V

# NLAS5223C, NLAS5223CL

## NLAS5223C DC CHARACTERISTICS – DIGITAL SECTION (Voltages Referenced to GND)

Symbol	Parameter	Condition	V <sub>CC</sub>	Guaranteed Limit		Unit
				25°C	-40°C to +85°C	
V <sub>IH</sub>	Minimum High-Level Input Voltage, Select Inputs		3.0 4.3	1.4 2.0	1.4 2.0	V
V <sub>IL</sub>	Maximum Low-Level Input Voltage, Select Inputs		3.0 4.3	0.7 0.8	0.7 0.8	V
I <sub>IN</sub>	Maximum Input Leakage Current, Select Inputs	V <sub>IN</sub> = V <sub>CC</sub> or GND	4.3	±0.1	±1.0	μA
I <sub>OFF</sub>	Power Off Leakage Current	V <sub>IN</sub> = V <sub>CC</sub> or GND	0	±0.5	±2.0	μA
I <sub>CC</sub>	Maximum Quiescent Supply Current (Note 2)	Select and V <sub>IS</sub> = V <sub>CC</sub> or GND	1.65 to 4.5	±1.0	±2.0	μA

2. Guaranteed by design. Resistance measurements do not include test circuit or package resistance.

## NLAS5223C DC ELECTRICAL CHARACTERISTICS – ANALOG SECTION

Symbol	Parameter	Condition	V <sub>CC</sub>	Guaranteed Maximum Limit				Unit
				25°C		-40°C to +85°C		
				Min	Max	Min	Max	
R <sub>ON</sub>	NC/NO On-Resistance (Note 3)	V <sub>IN</sub> = V <sub>IL</sub> or V <sub>IN</sub> = V <sub>IH</sub> V <sub>IS</sub> = GND to V <sub>CC</sub> I <sub>COM</sub> = 100 mA	3.0 4.3		0.4 0.35		0.5 0.4	Ω
R <sub>FLAT</sub>	NC/NO On-Resistance Flatness (Notes 3 and 4)	I <sub>COM</sub> = 100 mA V <sub>IS</sub> = 0 to V <sub>CC</sub>	3.0 4.3		0.16 0.11		0.20 0.14	Ω
ΔR <sub>ON</sub>	On-Resistance Match Between Channels (Notes 3 and 5)	V <sub>IS</sub> = 1.5 V; I <sub>COM</sub> = 100 mA V <sub>IS</sub> = 2.2 V; I <sub>COM</sub> = 100 mA	3.0 4.3		0.05 0.05		0.05 0.05	Ω
I <sub>NC(OFF)</sub> I <sub>NO(OFF)</sub>	NC or NO Off Leakage Current (Note 3)	V <sub>IN</sub> = V <sub>IL</sub> or V <sub>IH</sub> V <sub>NO</sub> or V <sub>NC</sub> = 0.3 V V <sub>COM</sub> = 4.0 V	4.3	-5.0	5.0	-50	50	nA
I <sub>COM(ON)</sub>	COM ON Leakage Current (Note 3)	V <sub>IN</sub> = V <sub>IL</sub> or V <sub>IH</sub> V <sub>NO</sub> 0.3 V or 4.0 V with V <sub>NC</sub> floating or V <sub>NC</sub> 0.3 V or 4.0 V with V <sub>NO</sub> floating V <sub>COM</sub> = 0.3 V or 4.0 V	4.3	-10	10	-100	100	nA

3. Guaranteed by design. Resistance measurements do not include test circuit or package resistance.

4. Flatness is defined as the difference between the maximum and minimum value of On-resistance as measured over the specified analog signal ranges.

5. ΔR<sub>ON</sub> = R<sub>ON(MAX)</sub> – R<sub>ON(MIN)</sub> between NC1 and NC2 or between NO1 and NO2.

# NLAS5223C, NLAS5223CL

## NLAS5223CL DC CHARACTERISTICS – DIGITAL SECTION (Voltages Referenced to GND)

Symbol	Parameter	Condition	V <sub>CC</sub>	Guaranteed Limit		Unit
				25°C	-40°C to +85°C	
V <sub>IH</sub>	Minimum High-Level Input Voltage, Select Inputs		3.0 4.3	1.3 1.6	1.3 1.6	V
V <sub>IL</sub>	Maximum Low-Level Input Voltage, Select Inputs		3.0 4.3	0.5 0.6	0.5 0.6	V
I <sub>IN</sub>	Maximum Input Leakage Current, Select Inputs	V <sub>IN</sub> = 4.5 V or GND	4.3	±0.1	±1.0	μA
I <sub>OFF</sub>	Power Off Leakage Current	V <sub>IN</sub> = 4.5 V or GND	0	±0.5	±2.0	μA
I <sub>CC</sub>	Maximum Quiescent Supply Current	Select and V <sub>IS</sub> = V <sub>CC</sub> or GND	1.65 to 4.5	±1.0	±2.0	μA
I <sub>CCV</sub>	Maximum Quiescent Supply Current, Low Voltage Driving (Note 6)	V <sub>IS</sub> = V <sub>CC</sub> or GND V <sub>IN</sub> = 1.65 V	4.3	±145	±150	μA
		V <sub>IS</sub> = V <sub>CC</sub> or GND V <sub>IN</sub> = 1.80 V		±125	±130	
		V <sub>IS</sub> = V <sub>CC</sub> or GND V <sub>IN</sub> = 2.60 V		±50	±55	

6. Guaranteed by design. Resistance measurements do not include test circuit or package resistance.

## NLAS5223CL DC ELECTRICAL CHARACTERISTICS – ANALOG SECTION

Symbol	Parameter	Condition	V <sub>CC</sub>	Guaranteed Maximum Limit				Unit
				25°C		-40°C to +85°C		
				Min	Max	Min	Max	
R <sub>ON</sub>	NC/NO On-Resistance (Note 7)	V <sub>IN</sub> = V <sub>IL</sub> or V <sub>IN</sub> = V <sub>IH</sub> V <sub>IS</sub> = GND to V <sub>CC</sub> I <sub>COM</sub> = 100 mA	3.0 4.3		0.4 0.35		0.5 0.4	Ω
R <sub>FLAT</sub>	NC/NO On-Resistance Flatness (Notes 7 and 8)	I <sub>COM</sub> = 100 mA V <sub>IS</sub> = 0 to V <sub>CC</sub>	3.0 4.3		0.16 0.11		0.20 0.14	Ω
ΔR <sub>ON</sub>	On-Resistance Match Between Channels (Notes 7 and 9)	V <sub>IS</sub> = 1.5 V; I <sub>COM</sub> = 100 mA V <sub>IS</sub> = 2.2 V; I <sub>COM</sub> = 100 mA	3.0 4.3		0.05 0.05		0.05 0.05	Ω
I <sub>NC(OFF)</sub> I <sub>NO(OFF)</sub>	NC or NO Off Leakage Current (Note 7)	V <sub>IN</sub> = V <sub>IL</sub> or V <sub>IH</sub> V <sub>NO</sub> or V <sub>NC</sub> = 0.3 V V <sub>COM</sub> = 4.0 V	4.3	-10	10	-100	100	nA
I <sub>COM(ON)</sub>	COM ON Leakage Current (Note 7)	V <sub>IN</sub> = V <sub>IL</sub> or V <sub>IH</sub> V <sub>NO</sub> 0.3 V or 4.0 V with V <sub>NC</sub> floating or V <sub>NC</sub> 0.3 V or 4.0 V with V <sub>NO</sub> floating V <sub>COM</sub> = 0.3 V or 4.0 V	4.3	-10	10	-100	100	nA

7. Guaranteed by design. Resistance measurements do not include test circuit or package resistance.

8. Flatness is defined as the difference between the maximum and minimum value of On-resistance as measured over the specified analog signal ranges.

9. ΔR<sub>ON</sub> = R<sub>ON(MAX)</sub> - R<sub>ON(MIN)</sub> between NC1 and NC2 or between NO1 and NO2.

# NLAS5223C, NLAS5223CL

## AC ELECTRICAL CHARACTERISTICS (Input $t_r = t_f = 3.0$ ns)

Symbol	Parameter	Test Conditions	$V_{CC}$ (V)	$V_{IS}$ (V)	Guaranteed Maximum Limit					Unit
					25°C			-40°C to +85°C		
					Min	Typ*	Max	Min	Max	
$t_{ON}$	Turn-On Time	$R_L = 50 \Omega$ , $C_L = 35$ pF (Figures 3 and 4)	2.3 – 4.5	1.5			50		60	ns
$t_{OFF}$	Turn-Off Time	$R_L = 50 \Omega$ , $C_L = 35$ pF (Figures 3 and 4)	2.3 – 4.5	1.5			30		40	ns
$t_{BBM}$	Minimum Break-Before-Make Time	$V_{IS} = 3.0$ $R_L = 50 \Omega$ , $C_L = 35$ pF (Figure 2)	3.0	1.5	2	15				ns

		Typical @ 25, $V_{CC} = 3.6$ V	
$C_{IN}$	Control Pin Input Capacitance	3.5	
$C_{NO/NC}$	NO, NC Port Capacitance	60	
$C_{COM}$	COM Port Capacitance When Switch is Enabled	200	

\*Typical Characteristics are at 25°C.

## ADDITIONAL APPLICATION CHARACTERISTICS (Voltages Referenced to GND Unless Noted)

Symbol	Parameter	Condition	$V_{CC}$ (V)	25°C	Unit
				Typical	
BW	Maximum On-Channel -3 dB Bandwidth or Minimum Frequency Response	$V_{IN}$ centered between $V_{CC}$ and GND (Figure 5)	1.65 – 4.5	24	MHz
$V_{ONL}$	Maximum Feed-through On Loss	$V_{IN} = 0$ dBm @ 100 kHz to 50 MHz $V_{IN}$ centered between $V_{CC}$ and GND (Figure 5)	1.65 – 4.5	-0.06	dB
$V_{ISO}$	Off-Channel Isolation	$f = 100$ kHz; $V_{IS} = 1$ V RMS; $C_L = 5.0$ pF $V_{IN}$ centered between $V_{CC}$ and GND (Figure 5)	1.65 – 4.5	-68	dB
Q	Charge Injection Select Input to Common I/O	$V_{IN} = V_{CC}$ to GND, $R_{IS} = 0 \Omega$ , $C_L = 1.0$ nF $Q = C_L \times DV_{OUT}$ (Figure 6)	1.65 – 4.5	38	pC
THD	Total Harmonic Distortion THD + Noise	$F_{IS} = 20$ Hz to 20 kHz, $R_L = R_{gen} = 600 \Omega$ , $C_L = 50$ pF $V_{IS} = 2.0$ V RMS	3.0	0.08	%
VCT	Channel-to-Channel Crosstalk	$f = 100$ kHz; $V_{IS} = 1.0$ V RMS, $C_L = 5.0$ pF, $R_L = 50 \Omega$ $V_{IN}$ centered between $V_{CC}$ and GND (Figure 5)	1.65 – 4.5	-70	dB

10. Off-Channel Isolation =  $20 \log_{10} (V_{COM}/V_{NO})$ ,  $V_{COM}$  = output,  $V_{NO}$  = input to off switch.

# NLAS5223C, NLAS5223CL

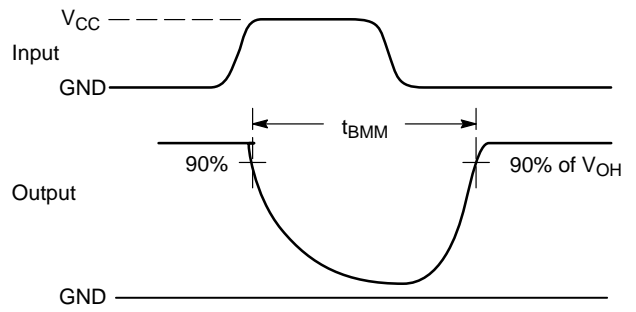
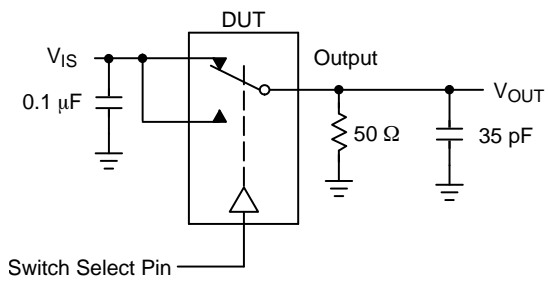


Figure 2.  $t_{BMM}$  (Time Break-Before-Make)

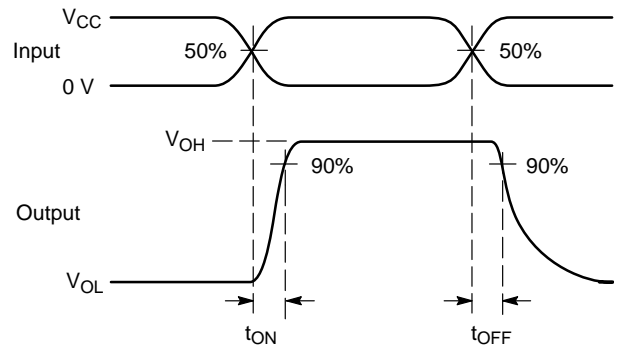
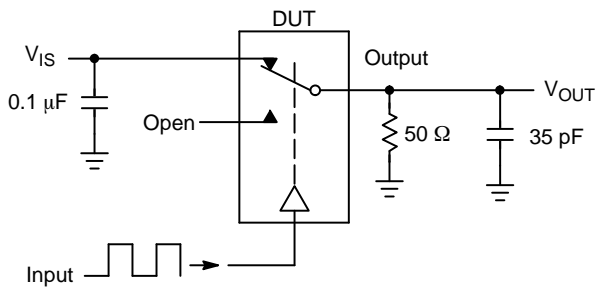


Figure 3.  $t_{ON}/t_{OFF}$

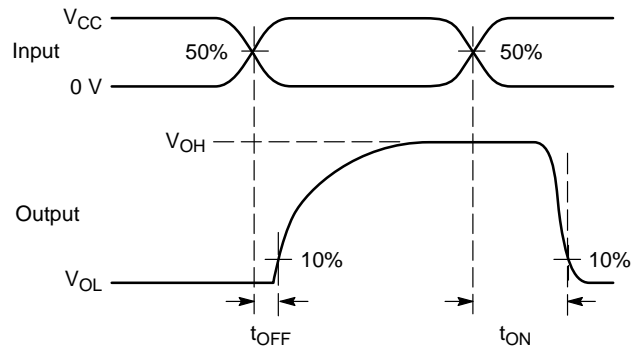
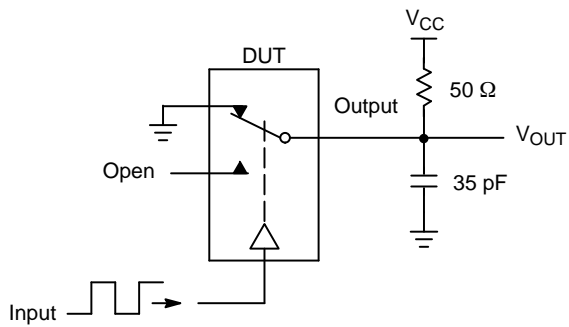
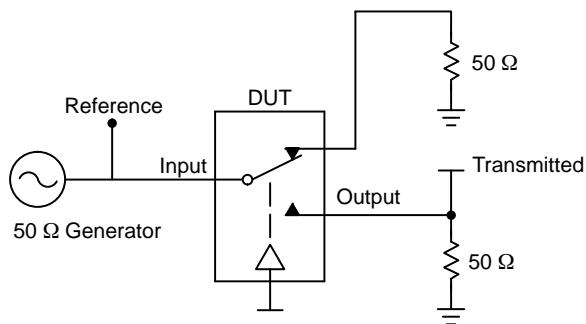


Figure 4.  $t_{ON}/t_{OFF}$

# NLAS5223C, NLAS5223CL



Channel switch control/s test socket is normalized. Off isolation is measured across an off channel. On loss is the bandwidth of an On switch.  $V_{ISO}$ , Bandwidth and  $V_{ONL}$  are independent of the input signal direction.

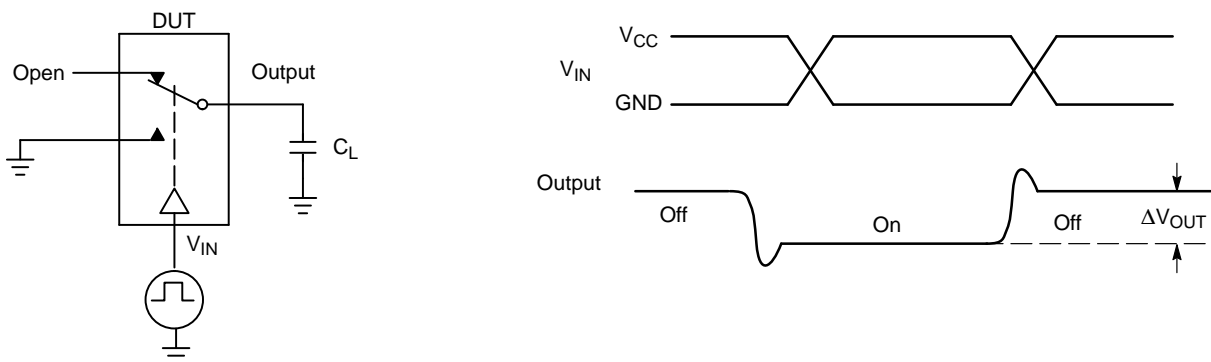
$$V_{ISO} = \text{Off Channel Isolation} = 20 \text{ Log} \left( \frac{V_{OUT}}{V_{IN}} \right) \text{ for } V_{IN} \text{ at } 100 \text{ kHz}$$

$$V_{ONL} = \text{On Channel Loss} = 20 \text{ Log} \left( \frac{V_{OUT}}{V_{IN}} \right) \text{ for } V_{IN} \text{ at } 100 \text{ kHz to } 50 \text{ MHz}$$

Bandwidth (BW) = the frequency 3 dB below  $V_{ONL}$

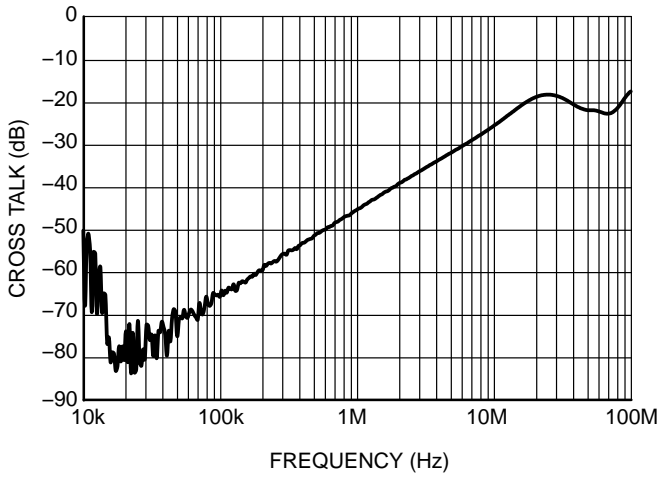
$V_{CT}$  = Use  $V_{ISO}$  setup and test to all other switch analog input/outputs terminated with 50  $\Omega$

**Figure 5. Off Channel Isolation/On Channel Loss (BW)/Crosstalk (On Channel to Off Channel)/ $V_{ONL}$**

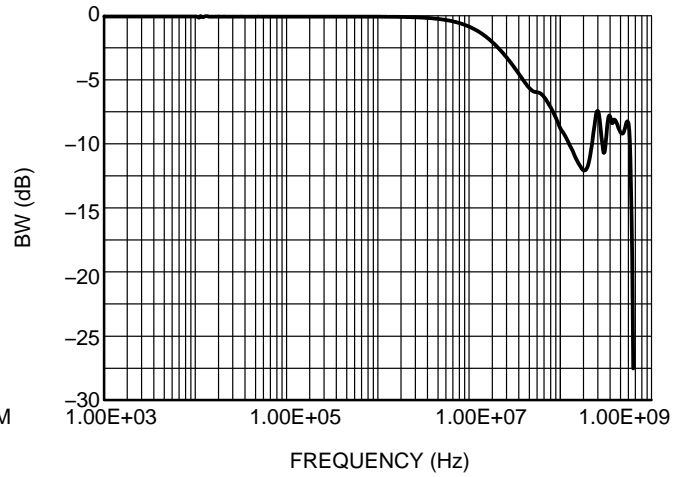


**Figure 6. Charge Injection: (Q)**

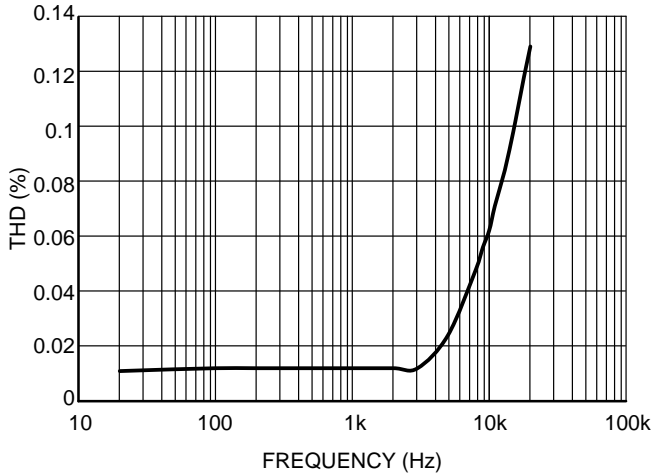
# NLAS5223C, NLAS5223CL



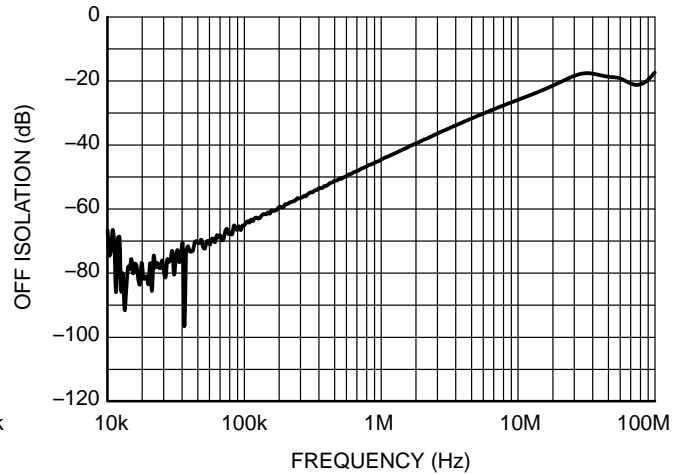
**Figure 7. Cross Talk vs. Frequency**  
( $V_{CC} = 3.0\text{ V}$ )



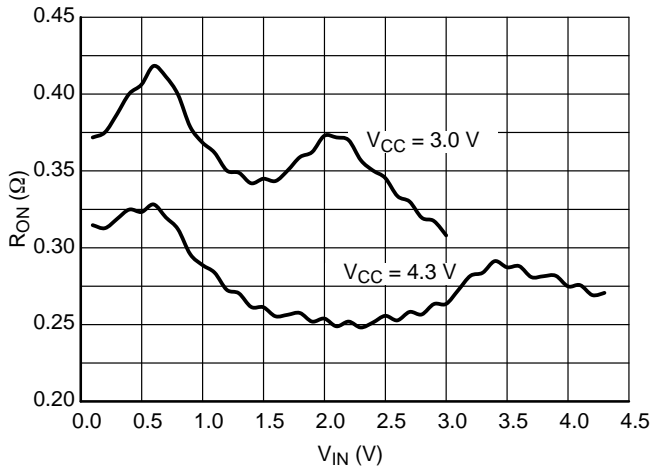
**Figure 8. Bandwidth**  
( $V_{CC} = 3.0\text{ V}$ )



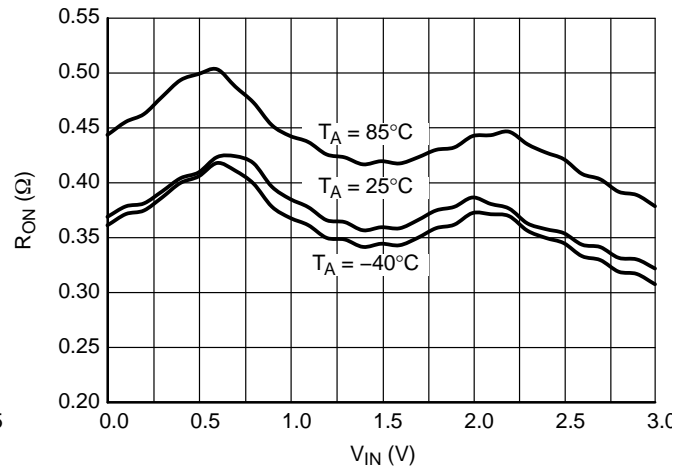
**Figure 9. Total Harmonic Distortion**  
( $V_{CC} = 3.0\text{ V}$ )



**Figure 10. Off Isolation**  
( $V_{CC} = 3.0\text{ V}$ )



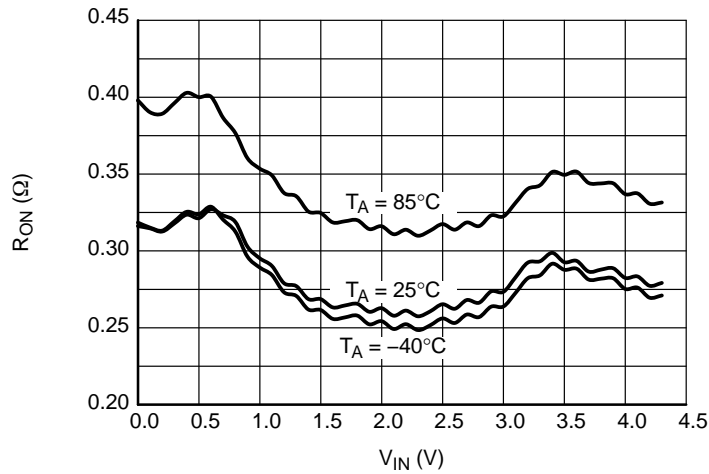
**Figure 11. On-Resistance vs. Input Voltage**  
@  $25^{\circ}\text{C}$  and  $V_{CC} = 3.0\text{ V}$  and  $4.3\text{ V}$



**Figure 12. On-Resistance vs. Input Voltage**  
@  $V_{CC} = 3.0\text{ V}$ ,  $T_A = -40^{\circ}\text{C}$  to  $85^{\circ}\text{C}$



## NLAS5223C, NLAS5223CL



**Figure 13. On-Resistance vs. Input Voltage**  
 @  $V_{CC} = 3.0\text{ V}$ ,  $T_A = -40^\circ\text{C}$  to  $85^\circ\text{C}$

### ORDERING INFORMATION

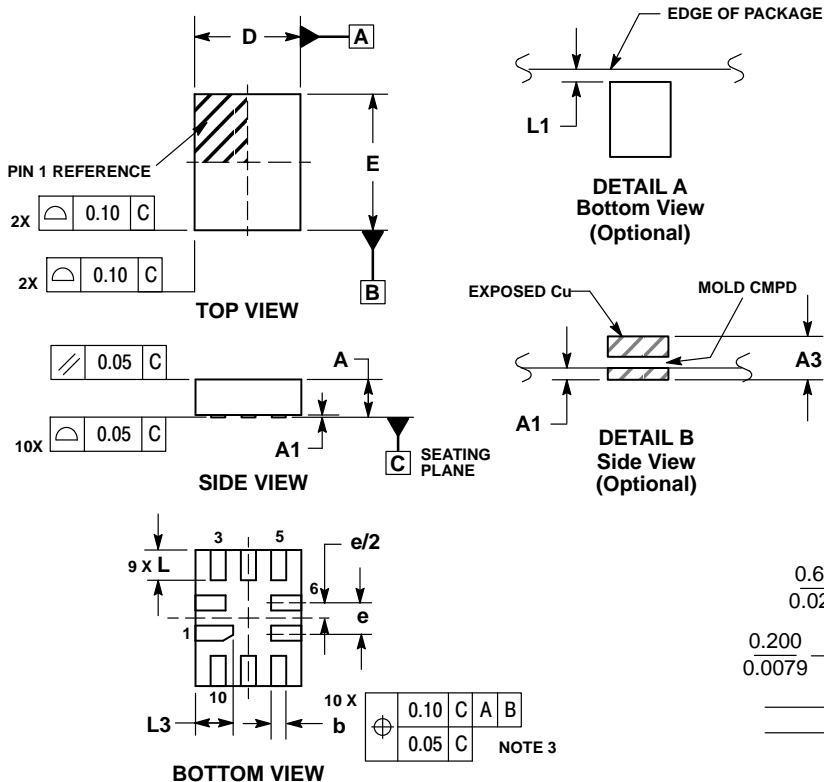
Device	Marking	Package	Shipping†
NLAS5223CMUTAG	AK	UQFN10 (Pb-Free)	3000 / Tape & Reel
NLAS5223CLMUTAG	AU	UQFN10 (Pb-Free)	3000 / Tape & Reel

†For information on tape and reel specifications, including part orientation and tape sizes, please refer to our Tape and Reel Packaging Specifications Brochure, BRD8011/D.

# NLAS5223C, NLAS5223CL

## PACKAGE DIMENSIONS

UQFN10, 1.4x1.8, 0.4P  
CASE 488AT  
ISSUE A

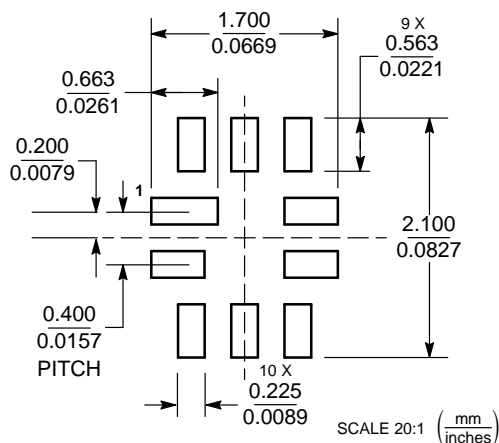


NOTES:

1. DIMENSIONING AND TOLERANCING PER ASME Y14.5M, 1994.
2. CONTROLLING DIMENSION: MILLIMETERS
3. DIMENSION b APPLIES TO PLATED TERMINAL AND IS MEASURED BETWEEN 0.25 AND 0.30 MM FROM TERMINAL.
4. COPLANARITY APPLIES TO THE EXPOSED PAD AS WELL AS THE TERMINALS.

MILLIMETERS		
DIM	MIN	MAX
A	0.45	0.60
A1	0.00	0.05
A3	0.127	REF
b	0.15	0.25
D	1.40	BSC
E	1.80	BSC
e	0.40	BSC
L	0.30	0.50
L1	0.00	0.15
L3	0.40	0.60

### MOUNTING FOOTPRINT



**ON Semiconductor** and **ON** are registered trademarks of Semiconductor Components Industries, LLC (SCILLC). SCILLC owns the rights to a number of patents, trademarks, copyrights, trade secrets, and other intellectual property. A listing of SCILLC's product/patent coverage may be accessed at [www.onsemi.com/site/pdf/Patent-Marking.pdf](http://www.onsemi.com/site/pdf/Patent-Marking.pdf). SCILLC reserves the right to make changes without further notice to any products herein. SCILLC makes no warranty, representation or guarantee regarding the suitability of its products for any particular purpose, nor does SCILLC assume any liability arising out of the application or use of any product or circuit, and specifically disclaims any and all liability, including without limitation special, consequential or incidental damages. "Typical" parameters which may be provided in SCILLC data sheets and/or specifications can and do vary in different applications and actual performance may vary over time. All operating parameters, including "Typicals" must be validated for each customer application by customer's technical experts. SCILLC does not convey any license under its patent rights nor the rights of others. SCILLC products are not designed, intended, or authorized for use as components in systems intended for surgical implant into the body, or other applications intended to support or sustain life, or for any other application in which the failure of the SCILLC product could create a situation where personal injury or death may occur. Should Buyer purchase or use SCILLC products for any such unintended or unauthorized application, Buyer shall indemnify and hold SCILLC and its officers, employees, subsidiaries, affiliates, and distributors harmless against all claims, costs, damages, and expenses, and reasonable attorney fees arising out of, directly or indirectly, any claim of personal injury or death associated with such unintended or unauthorized use, even if such claim alleges that SCILLC was negligent regarding the design or manufacture of the part. SCILLC is an Equal Opportunity/Affirmative Action Employer. This literature is subject to all applicable copyright laws and is not for resale in any manner.

### PUBLICATION ORDERING INFORMATION

**LITERATURE FULFILLMENT:**  
Literature Distribution Center for ON Semiconductor  
P.O. Box 5163, Denver, Colorado 80217 USA  
**Phone:** 303-675-2175 or 800-344-3860 Toll Free USA/Canada  
**Fax:** 303-675-2176 or 800-344-3867 Toll Free USA/Canada  
**Email:** [orderlit@onsemi.com](mailto:orderlit@onsemi.com)

**N. American Technical Support:** 800-282-9855 Toll Free  
USA/Canada  
**Europe, Middle East and Africa Technical Support:**  
Phone: 421 33 790 2910  
**Japan Customer Focus Center**  
Phone: 81-3-5817-1050

**ON Semiconductor Website:** [www.onsemi.com](http://www.onsemi.com)  
**Order Literature:** <http://www.onsemi.com/orderlit>

For additional information, please contact your local Sales Representative

Компания «Life Electronics» занимается поставками электронных компонентов импортного и отечественного производства от производителей и со складов крупных дистрибьюторов Европы, Америки и Азии.

С конца 2013 года компания активно расширяет линейку поставок компонентов по направлению коаксиальный кабель, кварцевые генераторы и конденсаторы (керамические, пленочные, электролитические), за счёт заключения дистрибьюторских договоров

Мы предлагаем:

- Конкурентоспособные цены и скидки постоянным клиентам.
- Специальные условия для постоянных клиентов.
- Подбор аналогов.
- Поставку компонентов в любых объемах, удовлетворяющих вашим потребностям.
- Приемлемые сроки поставки, возможна ускоренная поставка.
- Доставку товара в любую точку России и стран СНГ.
- Комплексную поставку.
- Работу по проектам и поставку образцов.
- Формирование склада под заказчика.
- Сертификаты соответствия на поставляемую продукцию (по желанию клиента).
- Тестирование поставляемой продукции.
- Поставку компонентов, требующих военную и космическую приемку.
- Входной контроль качества.
- Наличие сертификата ISO.

В составе нашей компании организован Конструкторский отдел, призванный помогать разработчикам, и инженерам.

Конструкторский отдел помогает осуществить:

- Регистрацию проекта у производителя компонентов.
- Техническую поддержку проекта.
- Защиту от снятия компонента с производства.
- Оценку стоимости проекта по компонентам.
- Изготовление тестовой платы монтаж и пусконаладочные работы.



Тел: +7 (812) 336 43 04 (многоканальный)

Email: [org@lifeelectronics.ru](mailto:org@lifeelectronics.ru)