

REVISIONS					
P.	LTN	DESCRIPTION	DATE	DMN	APVD
9		REVISED	18SEP2013	BL	AC
10		REVISED	20NOV2013	BL	JY
11		ADD 2170207-4	6MAY2015	RG	SH

NOTES, UNLESS OTHERWISE SPECIFIED:

- △ MATERIAL:  
 TOP CAGE: NICKEL SILVER, 0.25MM THICK  
 BOTTOM CAGE: STAINLESS STEEL, 0.25MM THICK  
 HEAT SINK: ALUMINUM  
 HEAT SINK CLIP: STAINLESS STEEL  
 EMI SPRING: COPPER ALLOY  
 GASKET RETENTION PLATE: STAINLESS STEEL  
 EMI GASKET: CONDUCTIVE RUBBER, UL 94V-0 RATED.
- △ PITCH BETWEEN PORTS OF ONE 1X6 CAGE ASSEMBLY.
- △ SPACING BETWEEN CAGES ON THE SAME PC BOARD, TO BE SPECIFIED BY CUSTOMER, MUST COMPLY WITH MINIMUM DIMENSIONS SHOWN.
- △ REFERENCE APPLICATION SPEC 114-13217 FOR RECOMMENDED DRILL HOLE DIAMETER AND PLATING THICKNESS.
- △ DATUMS AND BASIC DIMENSIONS ESTABLISHED BY CUSTOMER.
- △ DIMENSION F IS THE NOMINAL THICKNESS OF CUSTOMER SUPPLIED PC BOARD,  
 SINGLE SIDED PC BOARD MIN THICKNESS: 1.45MM.  
 DOUBLE SIDED PC BOARD MIN THICKNESS: 3.0MM.
- △ HEAT SINKS AND CLIP SHIPPED ASSEMBLED TO CAGE ASSEMBLY.
- △ DATUM -A- IS TOP SURFACE OF PC BOARD.

- △ DIMENSION APPLIES WITH MODULE INSERTED IN CAGE.
- △ UNPLATED THRU HOLES
- △ MATES WITH QSFP MSA COMPATIBLE TRANSCEIVER.
- △ SURFACE TRACES PERMITTED WITHIN THIS AREA EXCEPT WHERE CAGE STANDOFFS, SHOWN IN DETAIL S, CONTACT PC BOARD.
- △ BASELINE FOR THESE DIMENSIONS IS THE CENTER OF COMPLIANT PIN HOLE.
- △ DATE CODE (YYWWD) MARKED ON TOP OF CAGE AND CONCEALED BY HEAT SINKS APPLIES TO CAGE ASSEMBLY ONLY.
- △ REFERENCE APP SPEC 114-13217 FOR GASKET THICKNESS CALCULATION.
- △ FINISH:  
 EMI SPRING: 2um MINIMUM TIN.  
 HEAT SINK: NICKEL PLATING.

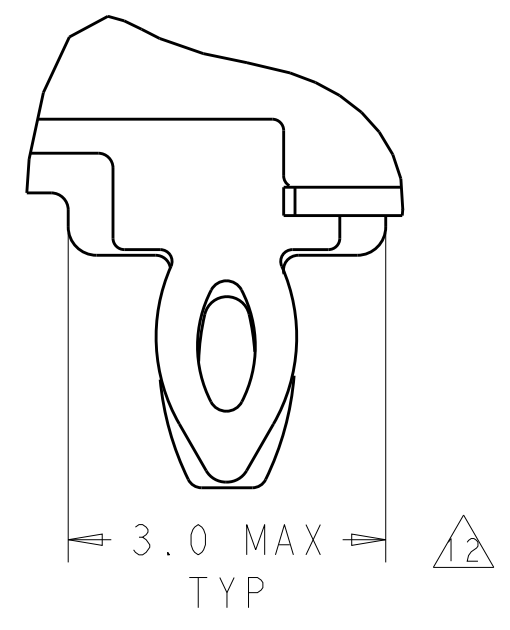

DETAIL S  
 SCALE 15:1

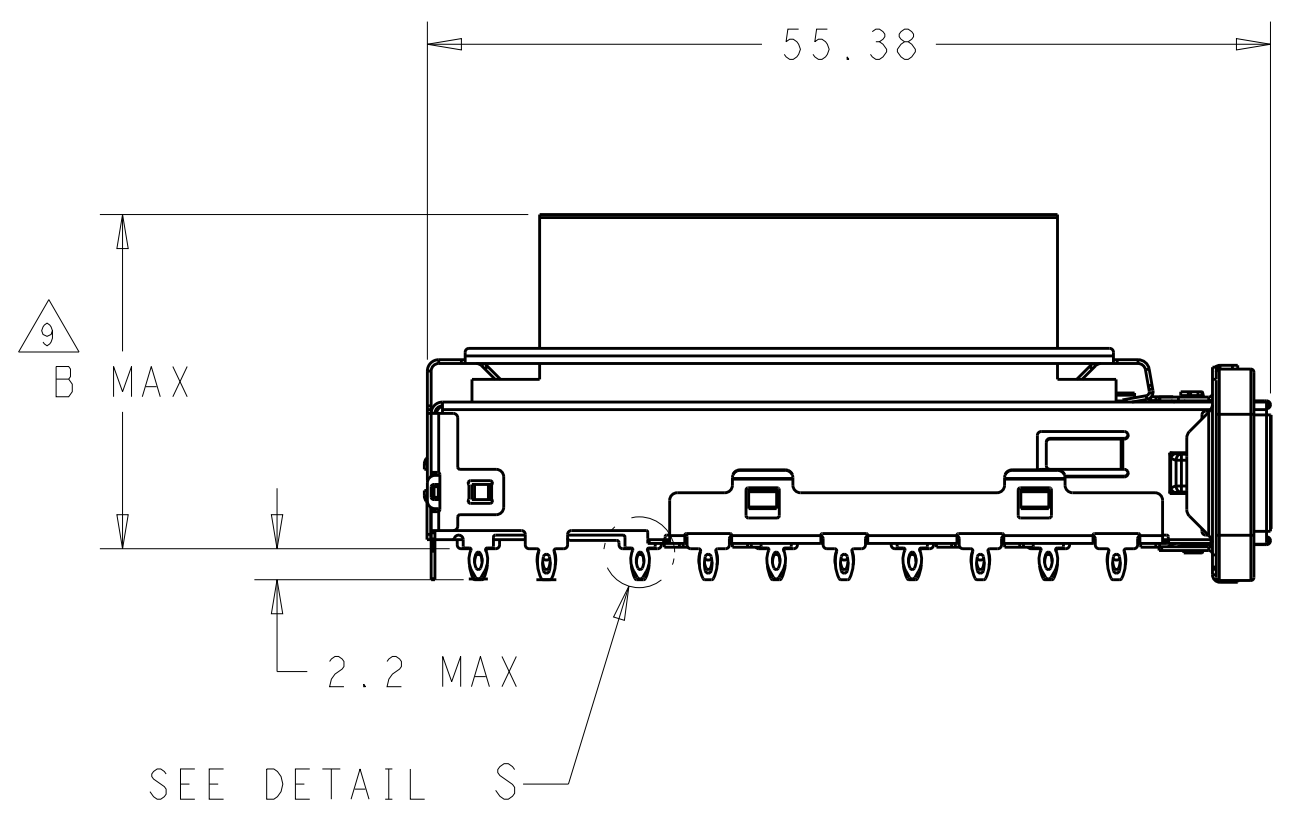

SCALE 2:1

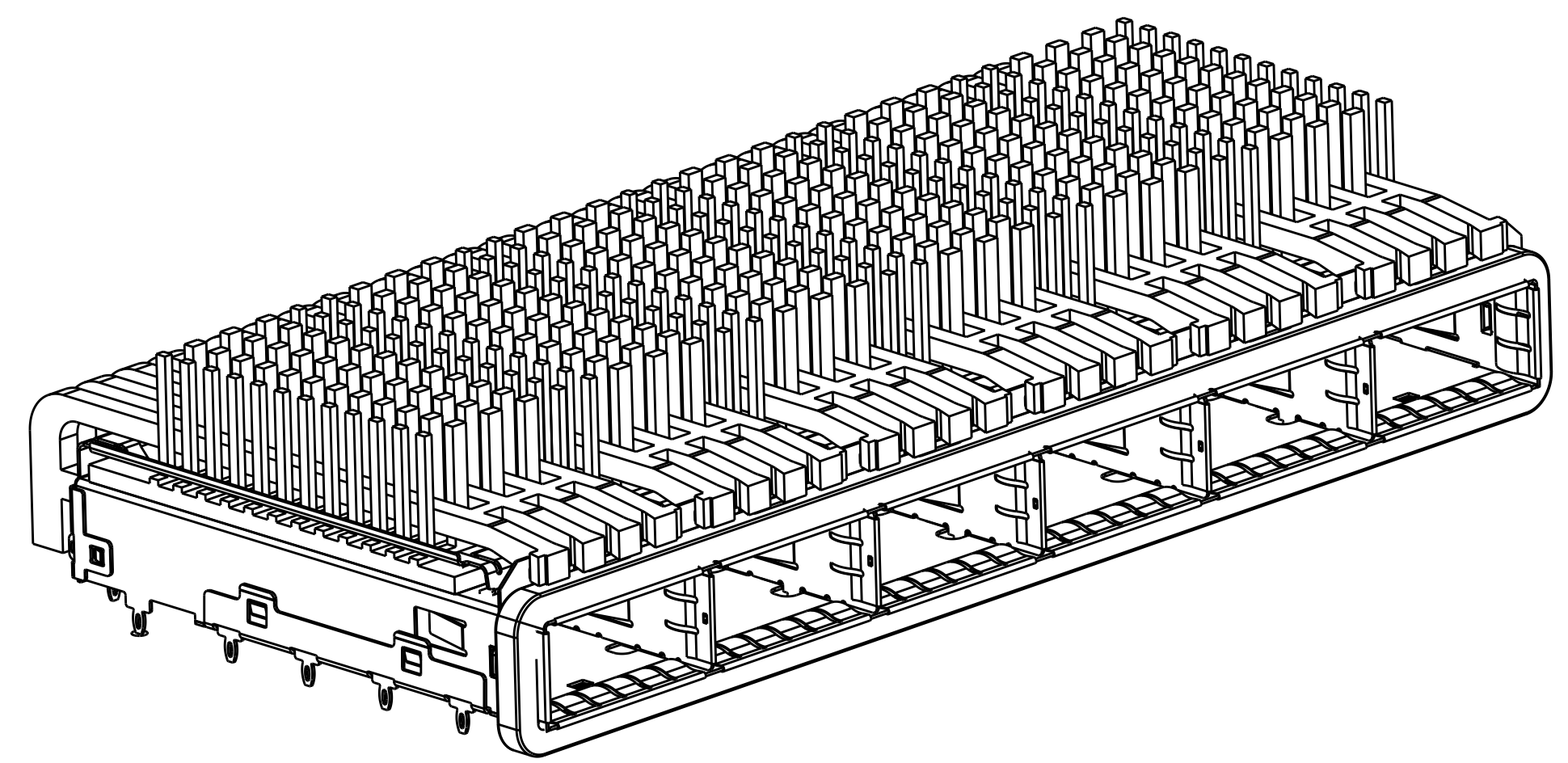
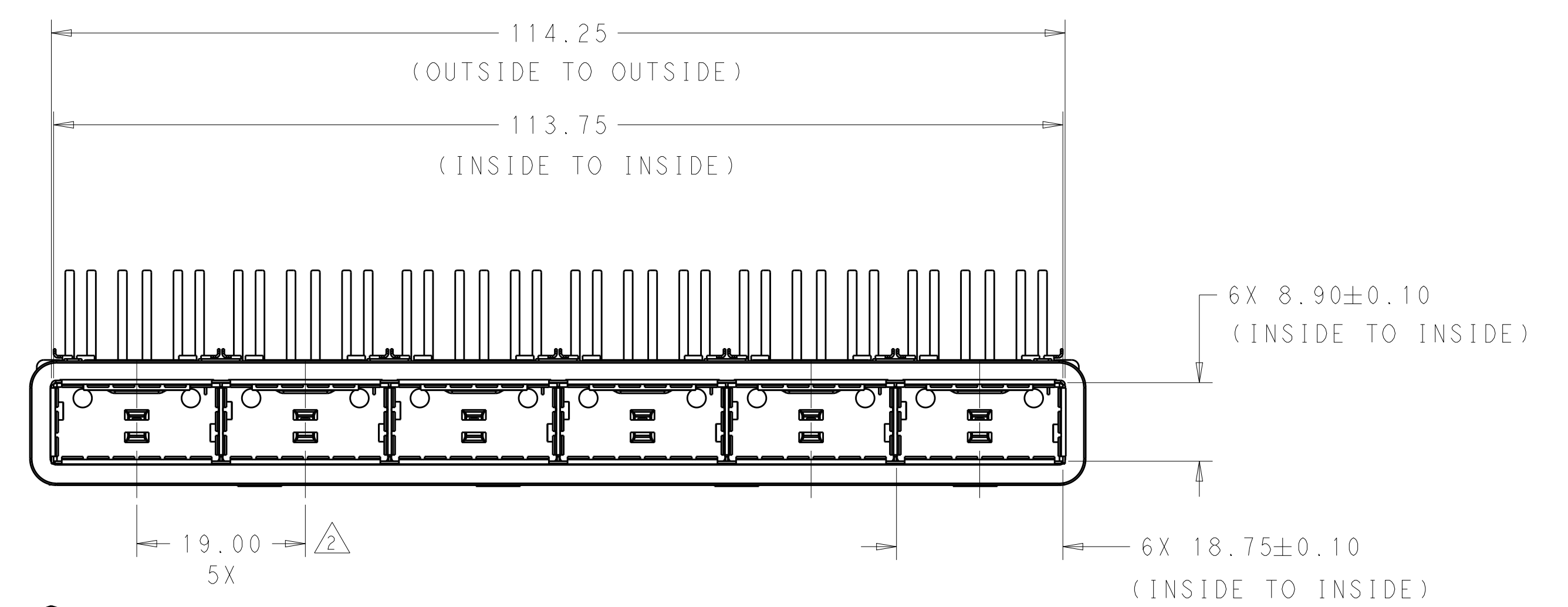

2170207-4  
 SCALE 2:1

WITH	23.0	Networking pin type	2170207-4
WITHOUT	23.0	Networking FIN TYPE	2170207-3
WITHOUT	16.0	SAN FIN TYPE	2170207-2
WITHOUT	13.7	PCI FIN TYPE	2170207-1
LIGHT PIPE	DIM.B	HEAT SINK	PART NUMBER

THIS DRAWING IS A CONTROLLED DOCUMENT.		DMN	ROBERT GAN	15NOV2012
DIMENSIONS:		CHK	JASON YANG	15NOV2012
mm		APVD	AILEY CAI	15NOV2012
TOLERANCES UNLESS OTHERWISE SPECIFIED:		NAME		
0 PLC	±	PRODUCT SPEC		
1 PLC	±0.2	108-2286		
2 PLC	±0.20	APPLICATION SPEC		
3 PLC	±	114-13217		
4 PLC	±	WEIGHT		
ANGLES	±	A100779C=2170207		
MATERIAL	FINISH	Customer Drawing		
		SCALE	1:1	SHEET 1 OF 6
		REV 12		

**PRELIMINARY**  
 STE TE Connectivity

REVISIONS				
P.	LTN.	DESCRIPTION	DATE	APVD.
-	-	SEE SHEET 1	-	-

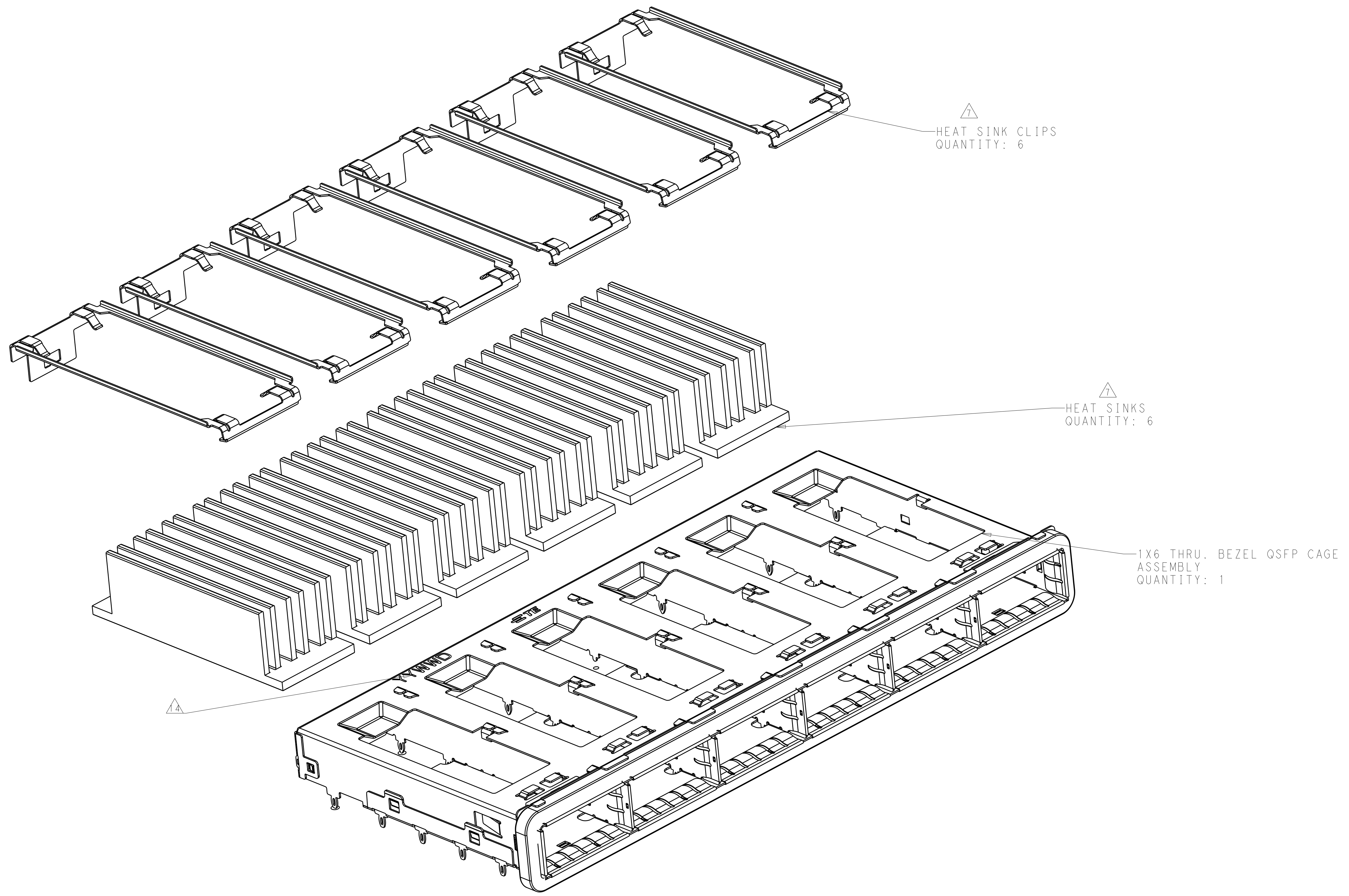

SCALE 3:1

THIS DRAWING IS A CONTROLLED DOCUMENT.		OWN: ROBERT GAN 15NOV2012	
DIMENSIONS: mm		CHK: JASON YANG 15NOV2012	
TOLERANCES UNLESS OTHERWISE SPECIFIED:		APVD: ALEY CAI 15NOV2012	NAME: 1X6 OSFP CAGE ASSY THRU BEZEL WITH HEAT SINK
0 PLC ±0.2	1 PLC ±0.2	PRODUCT SPEC: 108-2286	SIZE: A1
2 PLC ±0.20	3 PLC ±	APPLICATION SPEC: 114-13217	CAGE CODE: C=2170207
4 PLC ±	ANGLES ±	WEIGHT: -	RESTRICTED TO: -
MATERIAL: -	FINISH: -	Customer Drawing	SCALE: 1:1 SHEET 2 OF 6 REV 12

REVISIONS				
P.	LTN	DESCRIPTION	DATE	APVD
-	-	SEE SHEET 1	-	-

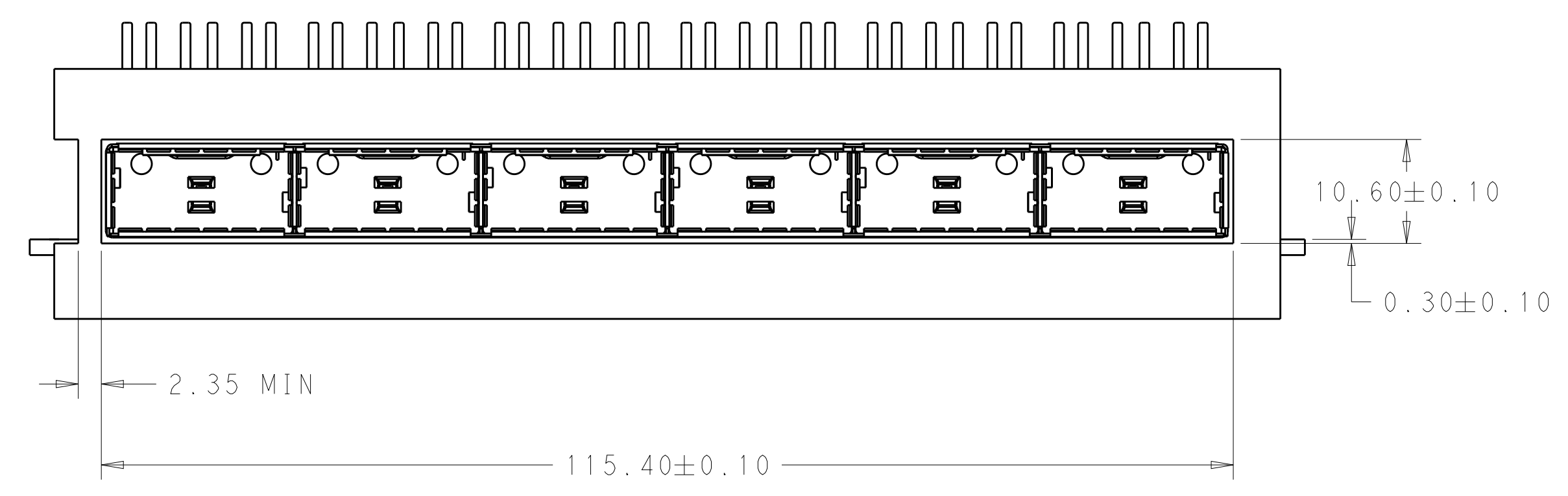

ONE SIDED CONFIGURATION

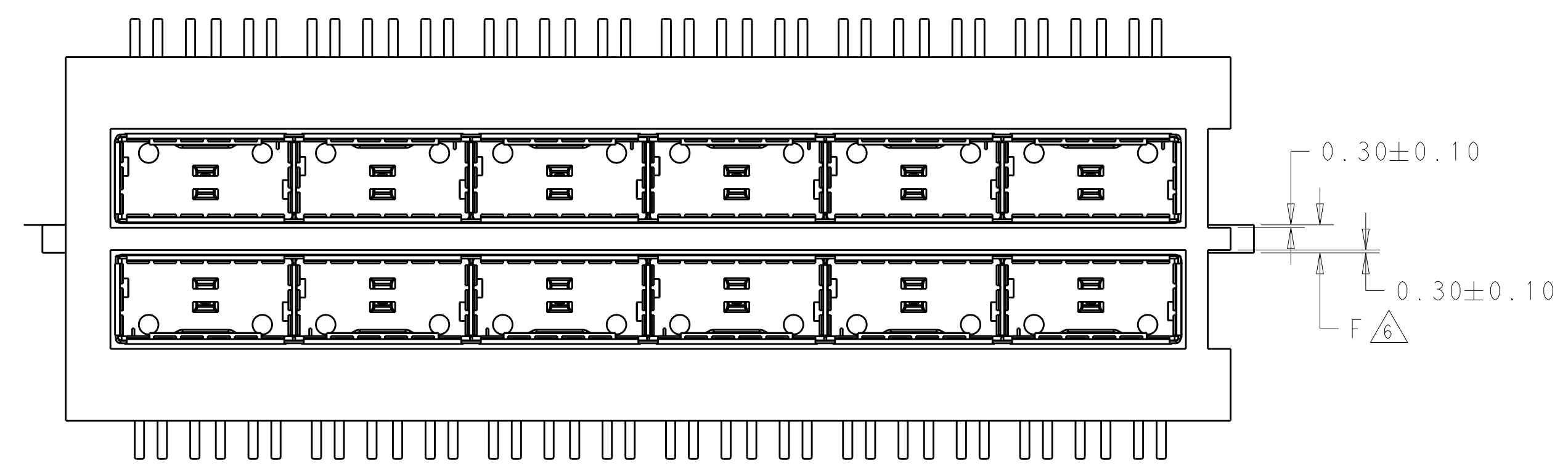

BELLY TO BELLY CONFIGURATION  
 SIMILAR TO ONE SIDED  
 EXCEPT WHERE NOTED

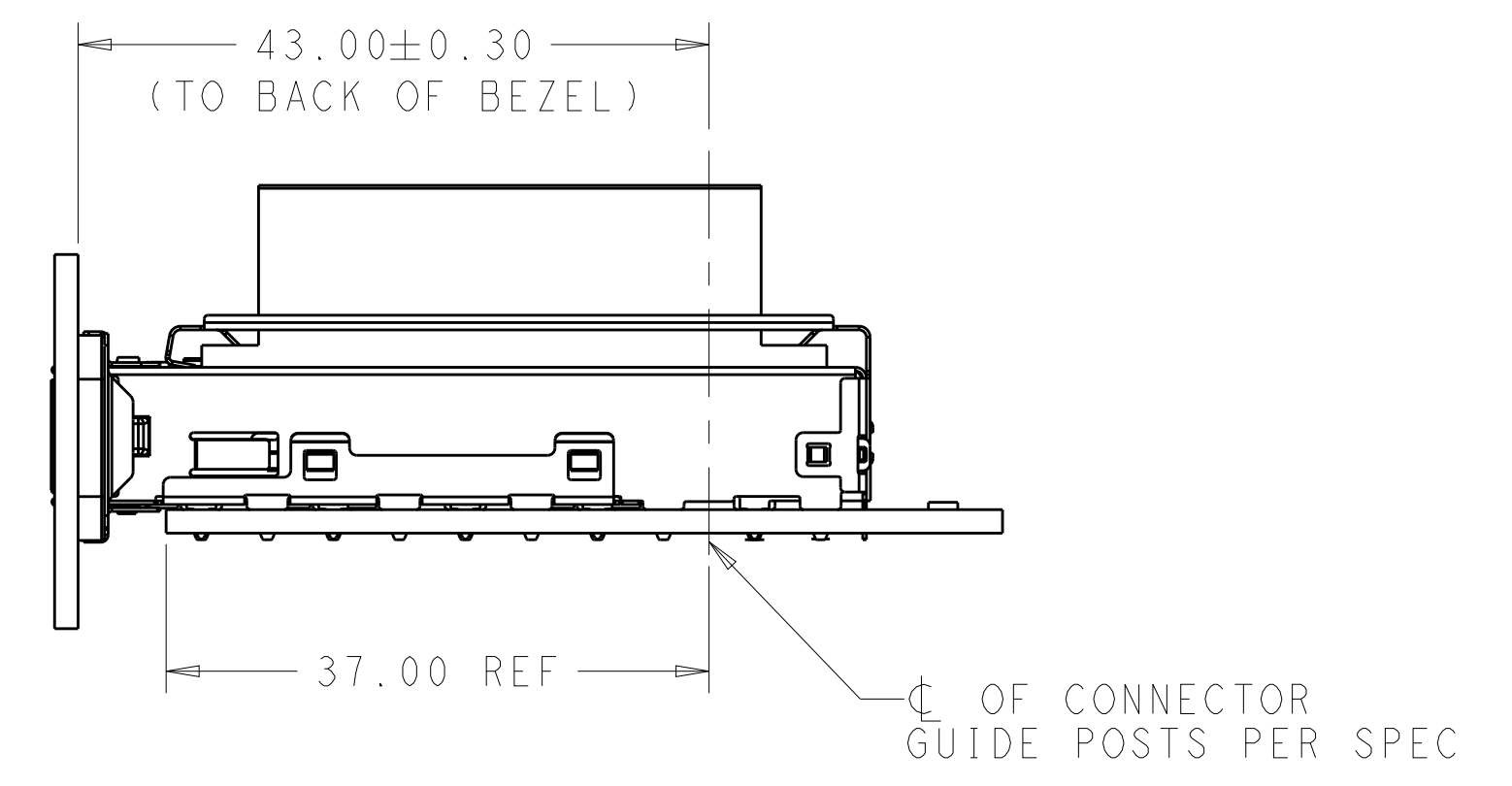

SCALE 2:1

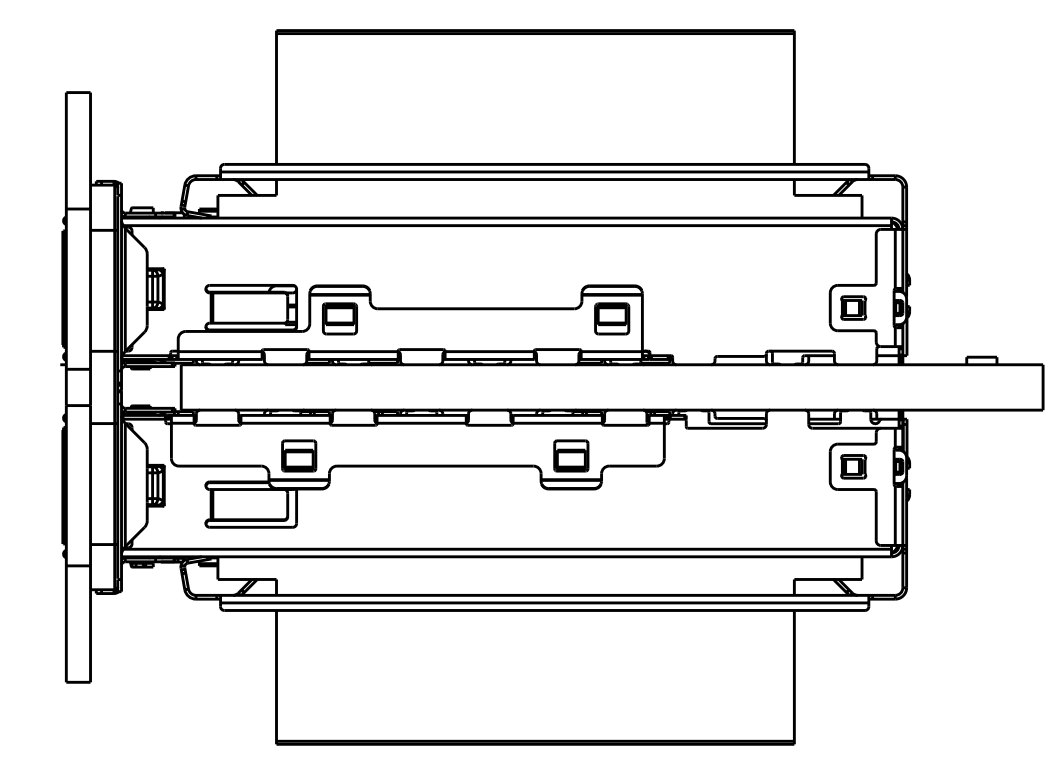

SCALE 2:1

THIS DRAWING IS A CONTROLLED DOCUMENT.		DWN: ROBERT GAN 15NOV2012	
		CHK: JASON YANG 15NOV2012	
DIMENSIONS:		APVD: ALEY CAI 15NOV2012	NAME: 1X6 QSFP CAGE ASSY THRU BEZEL WITH HEAT SINK PRODUCT SPEC: 108-2286 APPLICATION SPEC: 114-13217
TOLERANCES UNLESS OTHERWISE SPECIFIED: 0 PLC ± 1 PLC ±0.2 2 PLC ±0.20 3 PLC ± 4 PLC ± ANGLES ± FINISH ±		SIZE: CAGE CODE DRAWING NO WEIGHT: A100779C=2170207	
MATERIAL:		Customer Drawing	RESTRICTED TO:
		SCALE: 1:1	SHEET 3 OF 6 REV 12

REVISIONS				
P.	LTN	DESCRIPTION	DATE	APVD
-	-	SEE SHEET 1	-	-

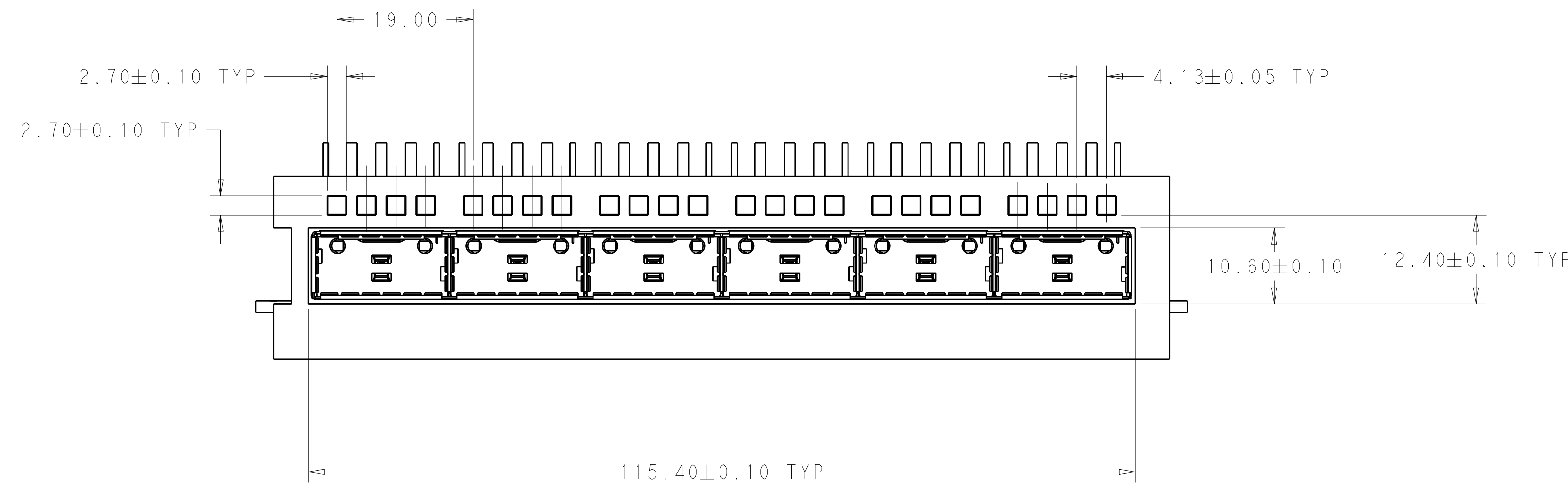

SCALE 2:1

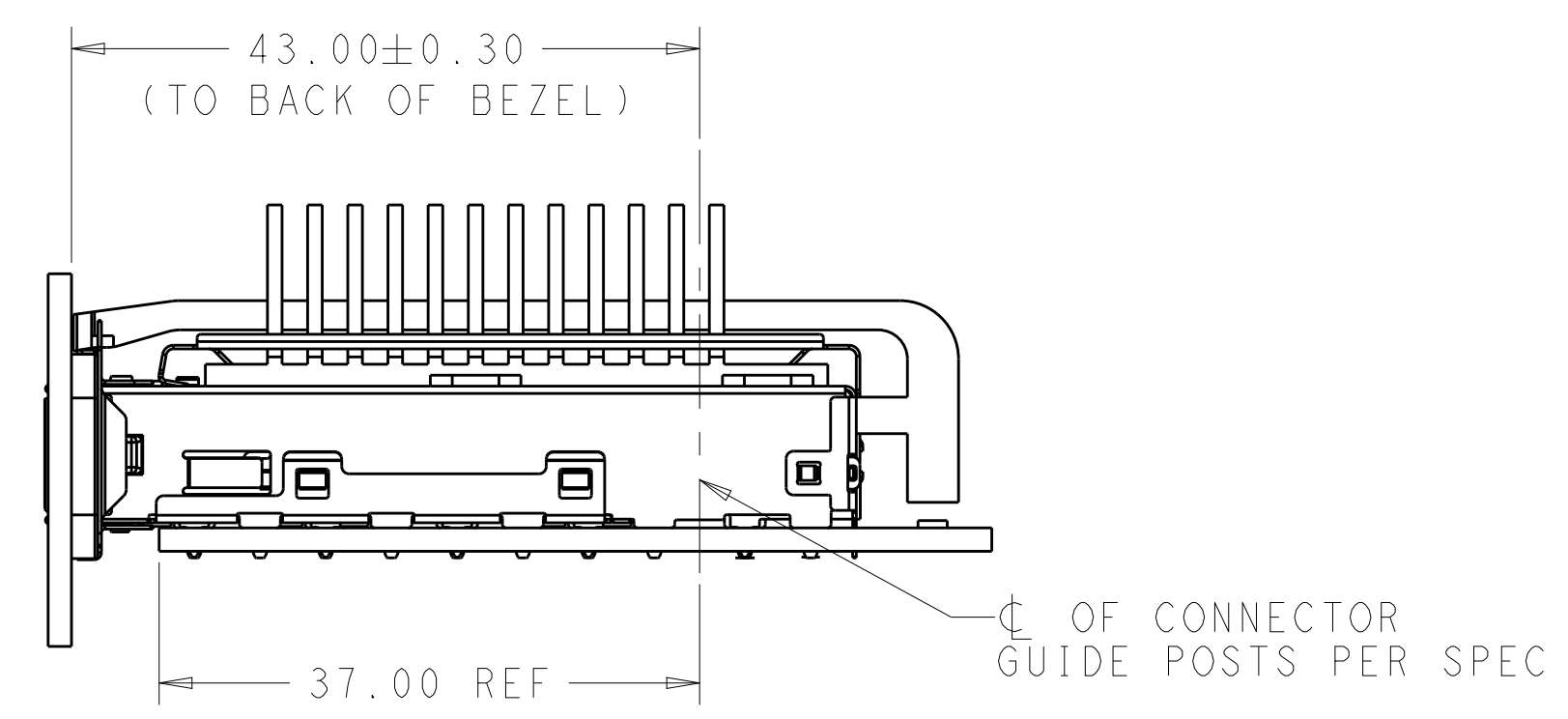

THIS DRAWING IS A CONTROLLED DOCUMENT.		DWN: ROBERT GAN 15NOV2012	TE Connectivity
DIMENSIONS: mm		CHK: JASON YANG 15NOV2012	
TOLERANCES UNLESS OTHERWISE SPECIFIED:		APVD: AILEY CAI 15NOV2012	NAME: 1X6 QSFP CAGE ASSY THRU BEZEL WITH HEAT SINK
0 PLC ±	1 PLC ±0.2	PRODUCT SPEC	SIZE: CAGE CODE DRAWING NO
2 PLC ±0.20	3 PLC ±	108-2286	RESTRICTED TO
4 PLC ±	ANGLES ±	APPLICATION SPEC	A100779C=2170207
MATERIAL: -	FINISH: -	114-13217	SCALE: 1:1 SHEET 4 OF 6 REV 12
Customer Drawing		WEIGHT: -	

REVISIONS				
P.	LTN	DESCRIPTION	DATE	APVD
-	-	SEE SHEET 1	-	-

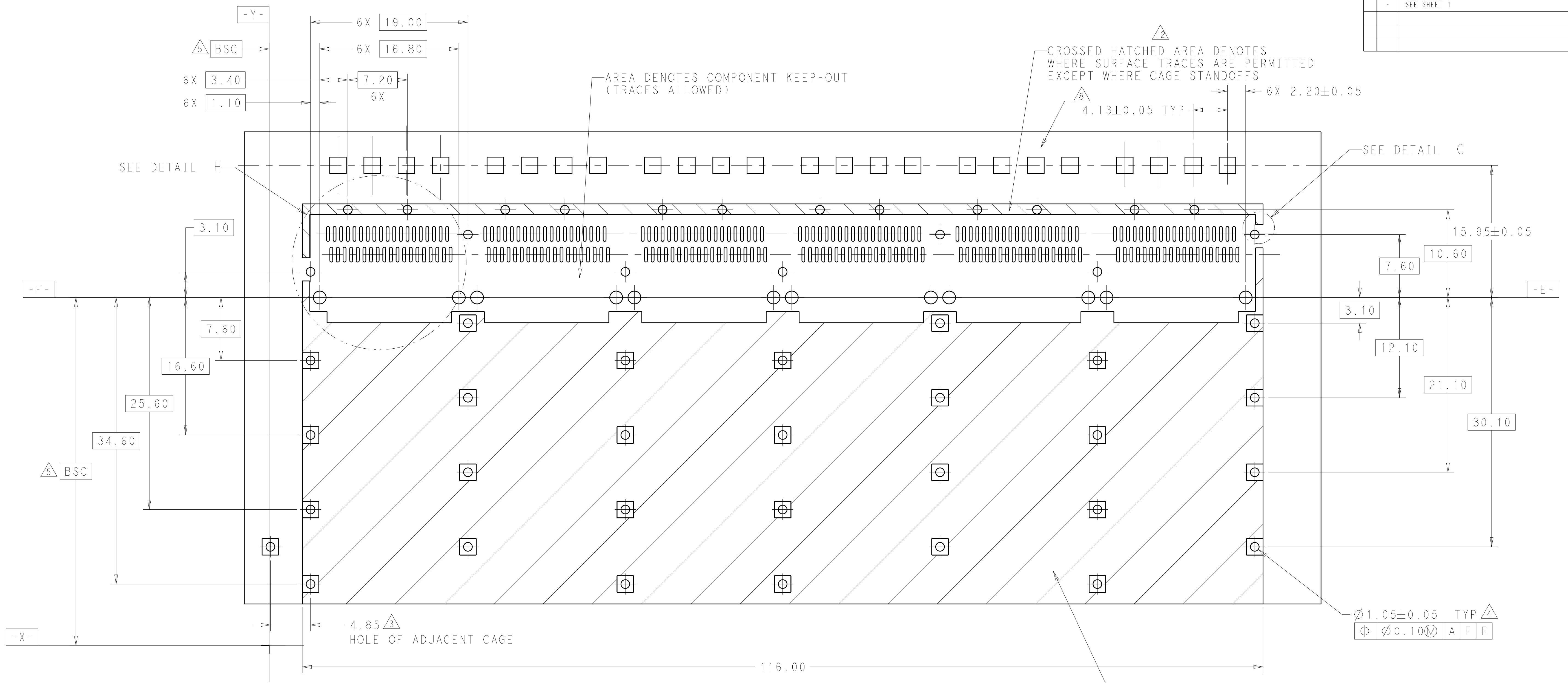

RECOMMENDED PC BOARD LAYOUT  
 SINGLE SIDE MOUNT CONFIGURATION

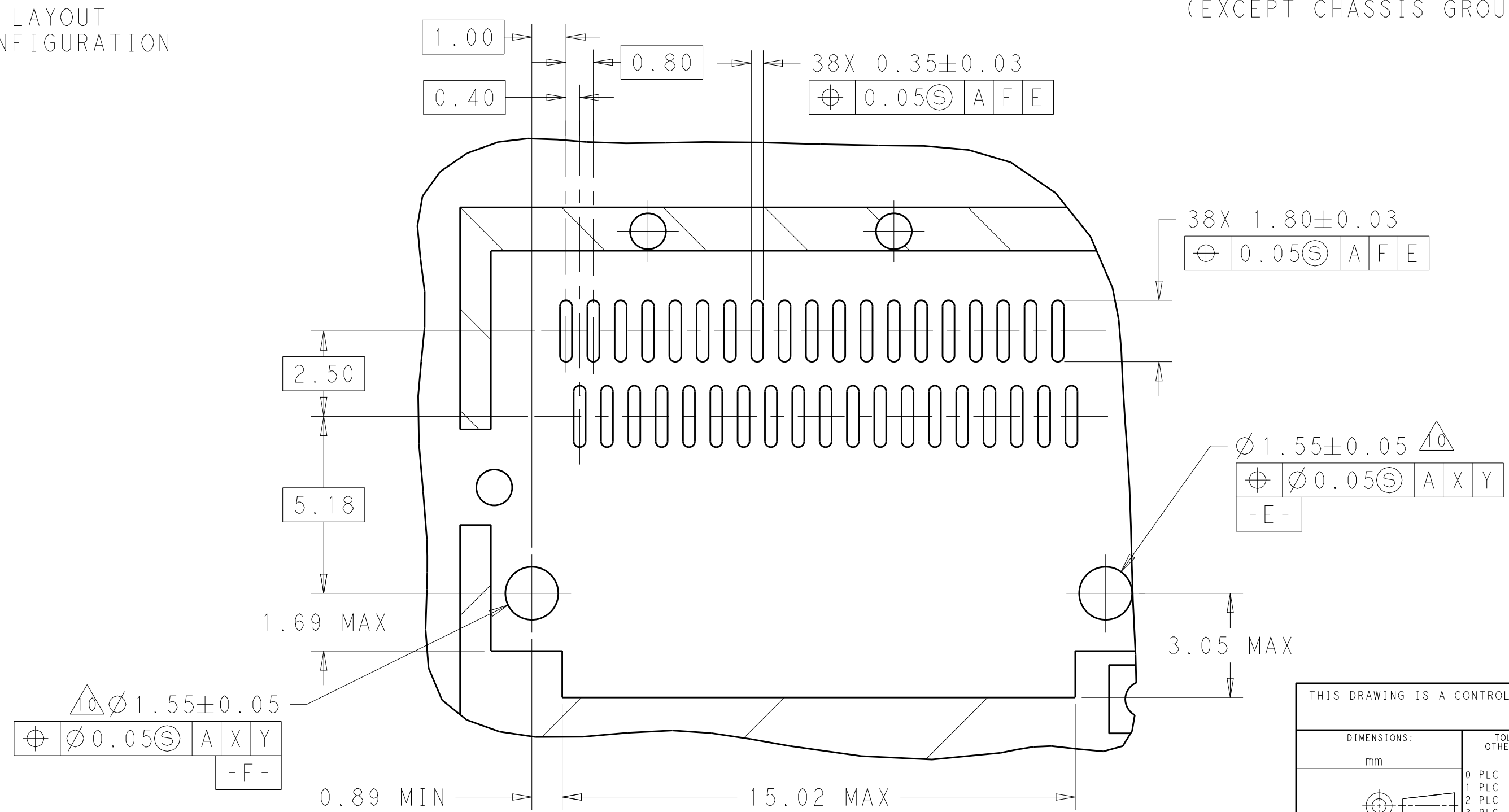
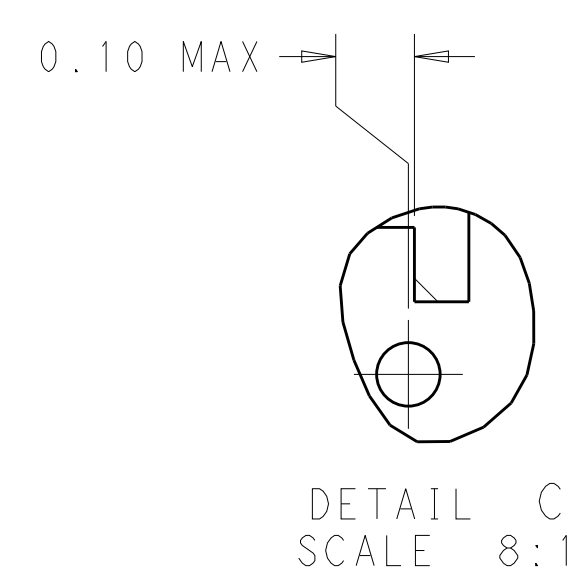

THIS DRAWING IS A CONTROLLED DOCUMENT.		OWN: ROBERT GAN 15NOV2012	TE Connectivity
		CHK: JASON YANG 15NOV2012	
		APVD: ALEY CAI 15NOV2012	NAME: 1X6 QSFP CAGE ASSY THRU BEZEL WITH HEAT SINK
		PRODUCT SPEC: 108-2286	SIZE: CAGE CODE DRAWING NO: A100779C=2170207
		APPLICATION SPEC: 114-13217	RESTRICTED TO: -
		WEIGHT: -	SCALE: 1:1 SHEET 5 OF 6 REV 12
		MATERIAL: -	Customer Drawing



REVISIONS				
P.	LTN.	DESCRIPTION	DATE	APPD.
-	-	SEE SHEET 1	-	-

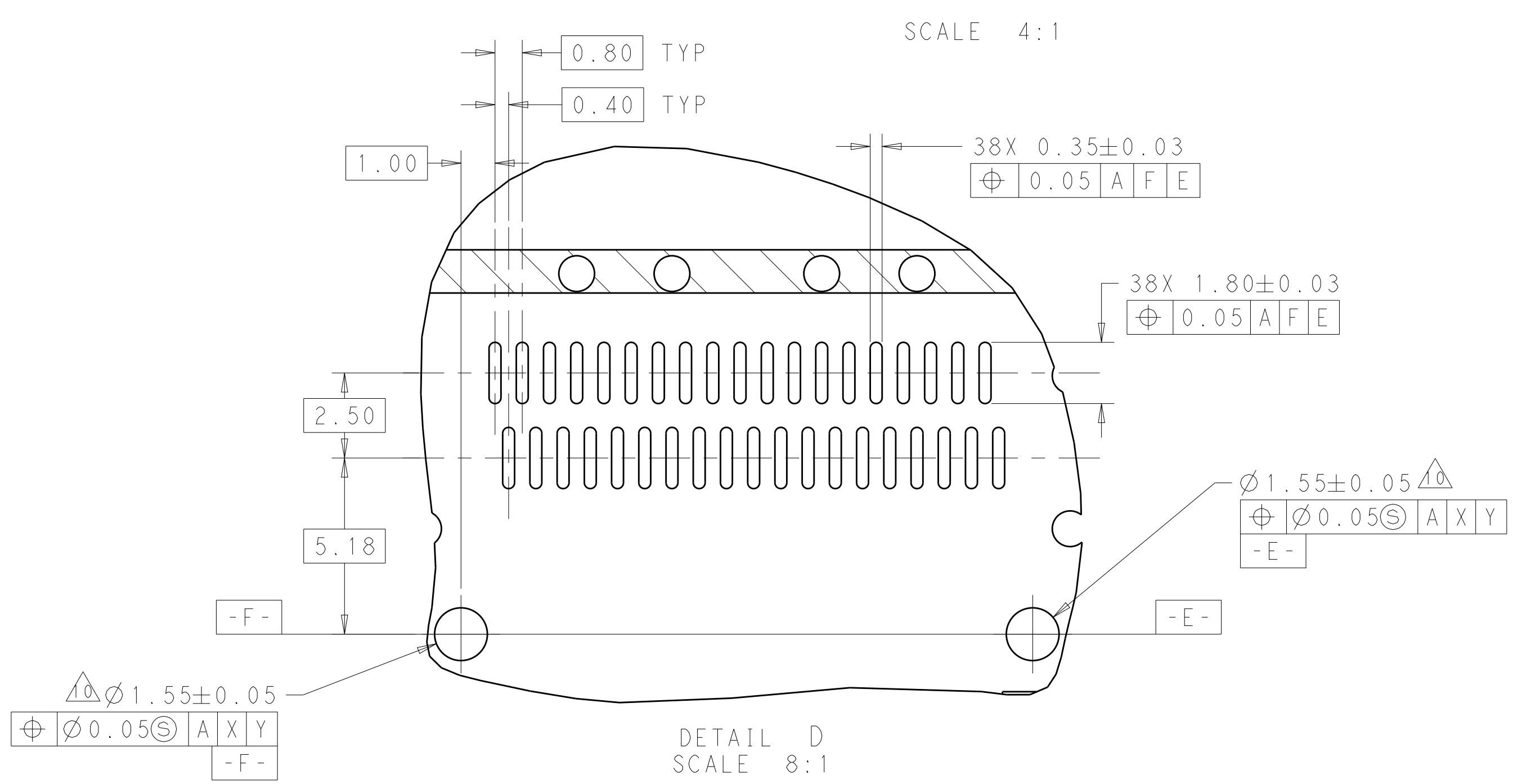
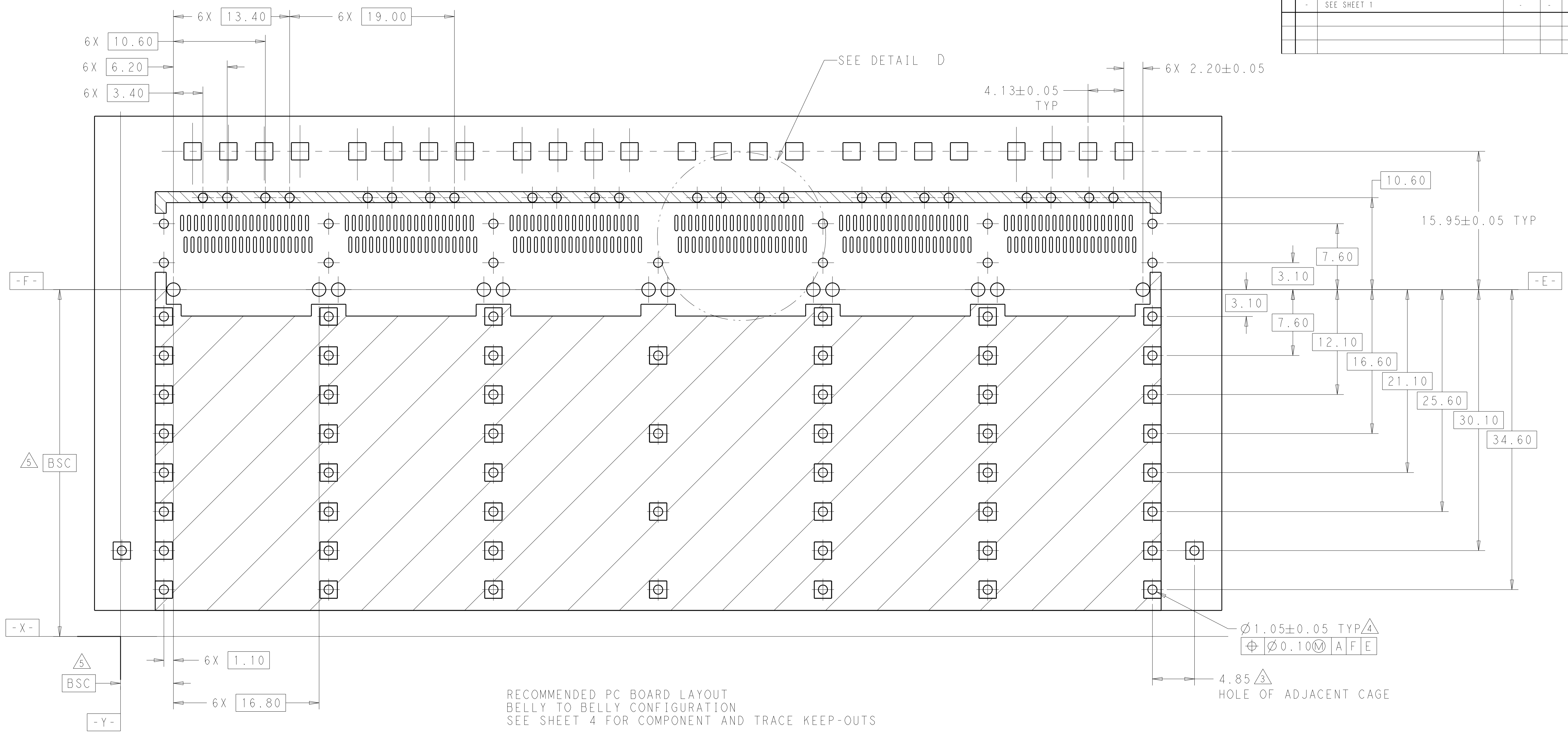

THIS DRAWING IS A CONTROLLED DOCUMENT.		DWN: ROBERT GAN 15NOV2012 CHK: JASON YANG 15NOV2012 APVD: AILEY CAI 15NOV2012	TE Connectivity
DIMENSIONS: mm TOLERANCES UNLESS OTHERWISE SPECIFIED: 0 PLC ± 1 PLC ±0.2 2 PLC ±0.20 3 PLC ± 4 PLC ± ANGLES ±		NAME: 1X6 OSFP CAGE ASSY THRU BEZEL WITH HEAT SINK PRODUCT SPEC: 108-2286 APPLICATION SPEC: 114-13217 WEIGHT:	
MATERIAL: FINISH:		SIZE: 114-13217 CAGE CODE: A100779 DRAWING NO: C=2170207 SCALE: 1:1	RESTRICTED TO: - SHEET 6 OF 6 REV 12

Компания «Life Electronics» занимается поставками электронных компонентов импортного и отечественного производства от производителей и со складов крупных дистрибьюторов Европы, Америки и Азии.

С конца 2013 года компания активно расширяет линейку поставок компонентов по направлению коаксиальный кабель, кварцевые генераторы и конденсаторы (керамические, пленочные, электролитические), за счёт заключения дистрибьюторских договоров

Мы предлагаем:

- Конкуренеспособные цены и скидки постоянным клиентам.
- Специальные условия для постоянных клиентов.
- Подбор аналогов.
- Поставку компонентов в любых объемах, удовлетворяющих вашим потребностям.
- Приемлемые сроки поставки, возможна ускоренная поставка.
- Доставку товара в любую точку России и стран СНГ.
- Комплексную поставку.
- Работу по проектам и поставку образцов.
- Формирование склада под заказчика.
- Сертификаты соответствия на поставляемую продукцию (по желанию клиента).
- Тестирование поставляемой продукции.
- Поставку компонентов, требующих военную и космическую приемку.
- Входной контроль качества.
- Наличие сертификата ISO.

В составе нашей компании организован Конструкторский отдел, призванный помогать разработчикам, и инженерам.

Конструкторский отдел помогает осуществить:

- Регистрацию проекта у производителя компонентов.
- Техническую поддержку проекта.
- Защиту от снятия компонента с производства.
- Оценку стоимости проекта по компонентам.
- Изготовление тестовой платы монтаж и пусконаладочные работы.



Тел: +7 (812) 336 43 04 (многоканальный)

Email: [org@lifeelectronics.ru](mailto:org@lifeelectronics.ru)