

THIS DRAWING IS UNPUBLISHED. RELEASED FOR PUBLICATION NOV. 2004.  
 © COPYRIGHT 2004 By - ALL RIGHTS RESERVED.

LOC	DIST	REVISIONS					
ES		P	LTR	DESCRIPTION	DATE	DWN	APVD
			B3	REVISED PER ECO-11-005033	29MAR11	RK	HMR

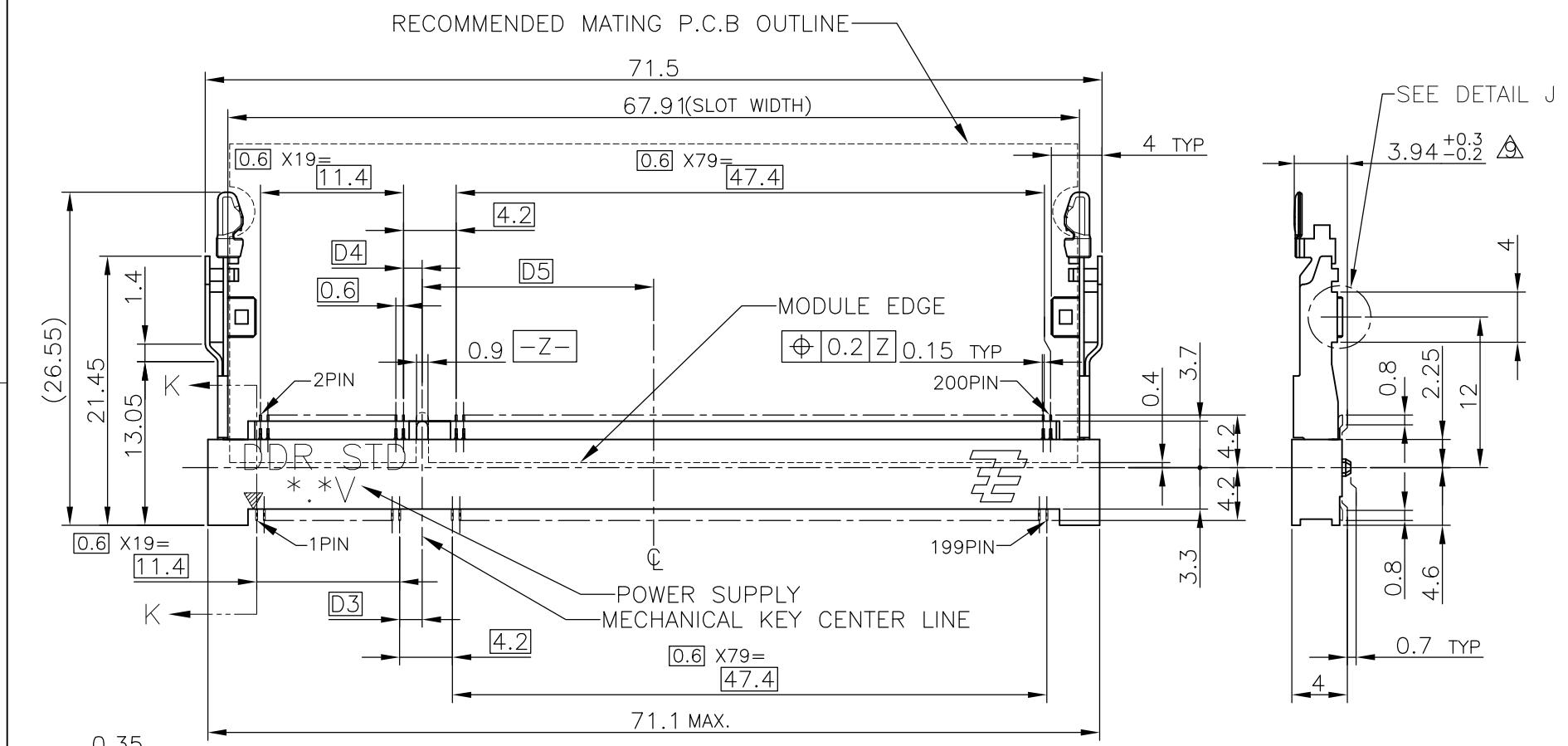

- (APPLIED TO SHEET 1-2)
- MATERIAL ; HOUSING: HIGH TEMPERATURE THERMO PLASTIC UL94V-0  
CONTACT: COPPER ARROY  
LOCK LEVER: STAINLESS STEEL
  - FINISH ; CONTACT AREA: GOLD FLASH ON 0.0013MIN ALL OVER NICKEL.  
SOLDERING AREA: GOLD FLASH PLATING.  
LOCK LEVER: TIN PLATING.
  - MECHANICAL KEY POSITION OF CONNECTOR SEE TABLE.
  - TOLERANCES NON-CUMULATIVE.
  - NOT TO SCALE.
  - INSIDE MUST BE RESIST COAT EXCEPT SOLDER PATTERN.
  - COPLANARITY : 0.1 MAX.
  - THE FLOATING VALUE BY SOLDERING IS NOT INCLUDED.
  - NOT MATING CONDITION.
  - IF THE MODULE DOESN'T INSERT AND LOCK IN THE LATCH SMOOTHLY, OPEN WIDE BOTH LATCHES BY MANUAL. AND THE MODULE MUST BE INSERTED AND LOCKED IN THE LATCH.
  - FINISH ; CONTACT AREA: GOLD PLATING 0.000254MIN ON 0.0013MIN ALL OVER NICKEL.  
SOLDERING AREA: GOLD FLASH PLATING.  
LOCK LEVER: TIN PLATING.

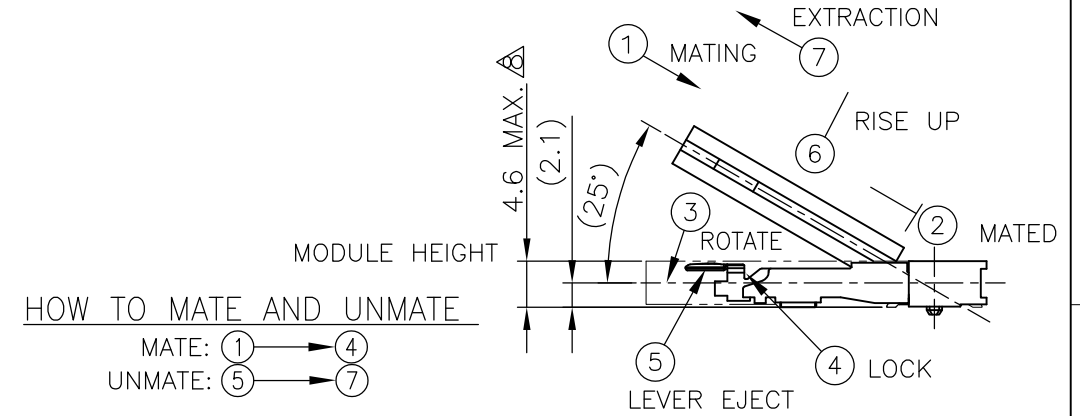
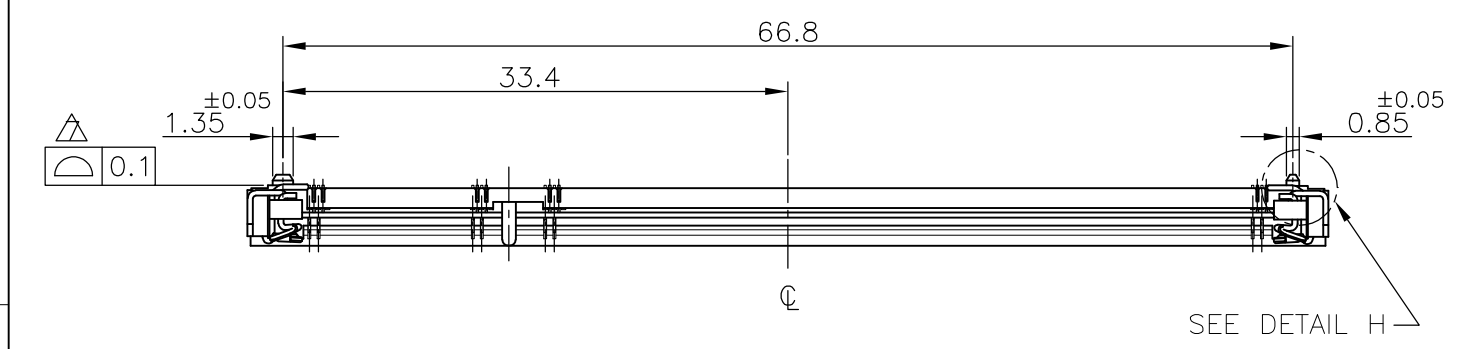
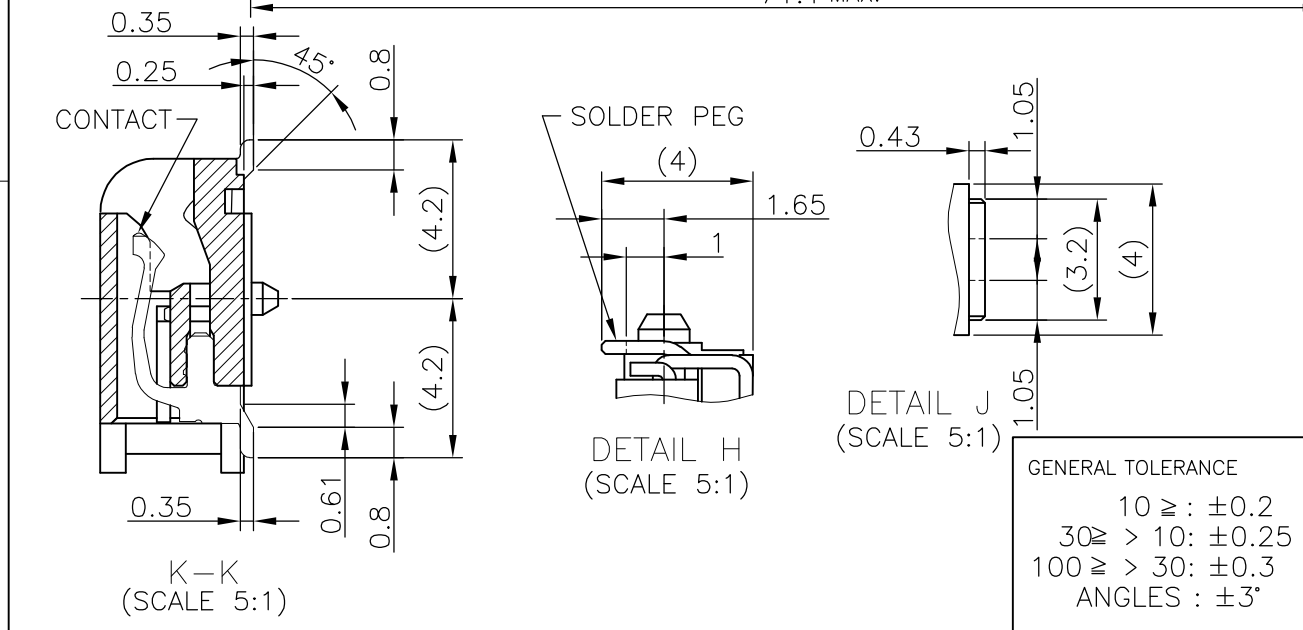

GENERAL TOLERANCE  
 10 ≥ : ±0.2  
 30 ≥ > 10: ±0.25  
 100 ≥ > 30: ±0.3  
 ANGLES : ±3'

AVAILABLE	△	1.8V (DDR2)	17.55	2.4	2.7	200	292406 -5
AVAILABLE	△	1.8V (DDR2)	17.55	2.4	2.7	200	292406 -4
TOOLING STATUS	REMARK	POWER SUPPLY	D5	D4	D3	POS	PART NO.
THIS DRAWING IS A CONTROLLED DOCUMENT.		DWN	LEO ZHOU	25MAY05			
		CHK	T.KAWAMAE	25MAY05			
		APVD	STEVEN YAO	25MAY05			
DIMENSIONS: MM		PRODUCT SPEC		NAME			
TOLERANCES UNLESS OTHERWISE SPECIFIED:		108-5701		DDR1 & DDR2 SODIMM SOCKET 0.6mm PITCH			
0 PLC ±		APPLICATION SPEC		200POS LOW PROFILE STANDARD TYPE			
1 PLC ±		WEIGHT		(LATCH DIRECT SOLDERING TYPE)			
2 PLC ±		3.2 g		SIZE	CAGE CODE	DRAWING NO	RESTRICTED TO
3 PLC ±		CUSTOMER DRAWING		A3	00779	C-292406	
4 PLC ±		SCALE		2:1		SHEET 1 OF 4	
ANGLES ±		REV		B3			
FINISH							

THIS DRAWING IS UNPUBLISHED. RELEASED FOR PUBLICATION NOV ,2004.  
 © COPYRIGHT 2004 By - ALL RIGHTS RESERVED.

LOC	DIST	REVISIONS					
ES		P	LTR	DESCRIPTION	DATE	DWN	APVD
		-		SEE SHEET 1	-	-	-

### REFERENCE P.C. BOARD PATTERN LAYOUT (CONNECTOR MOUNTING SIDE)

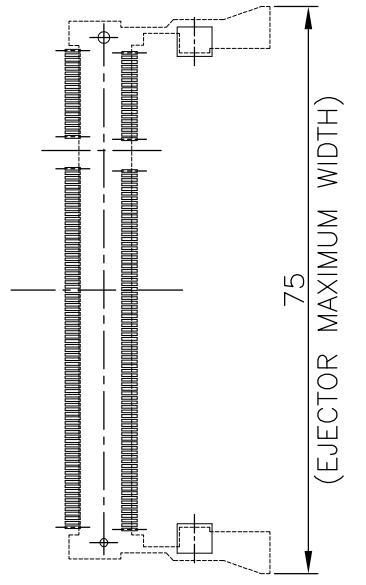

REAL SIZE (SCALE 1:1)

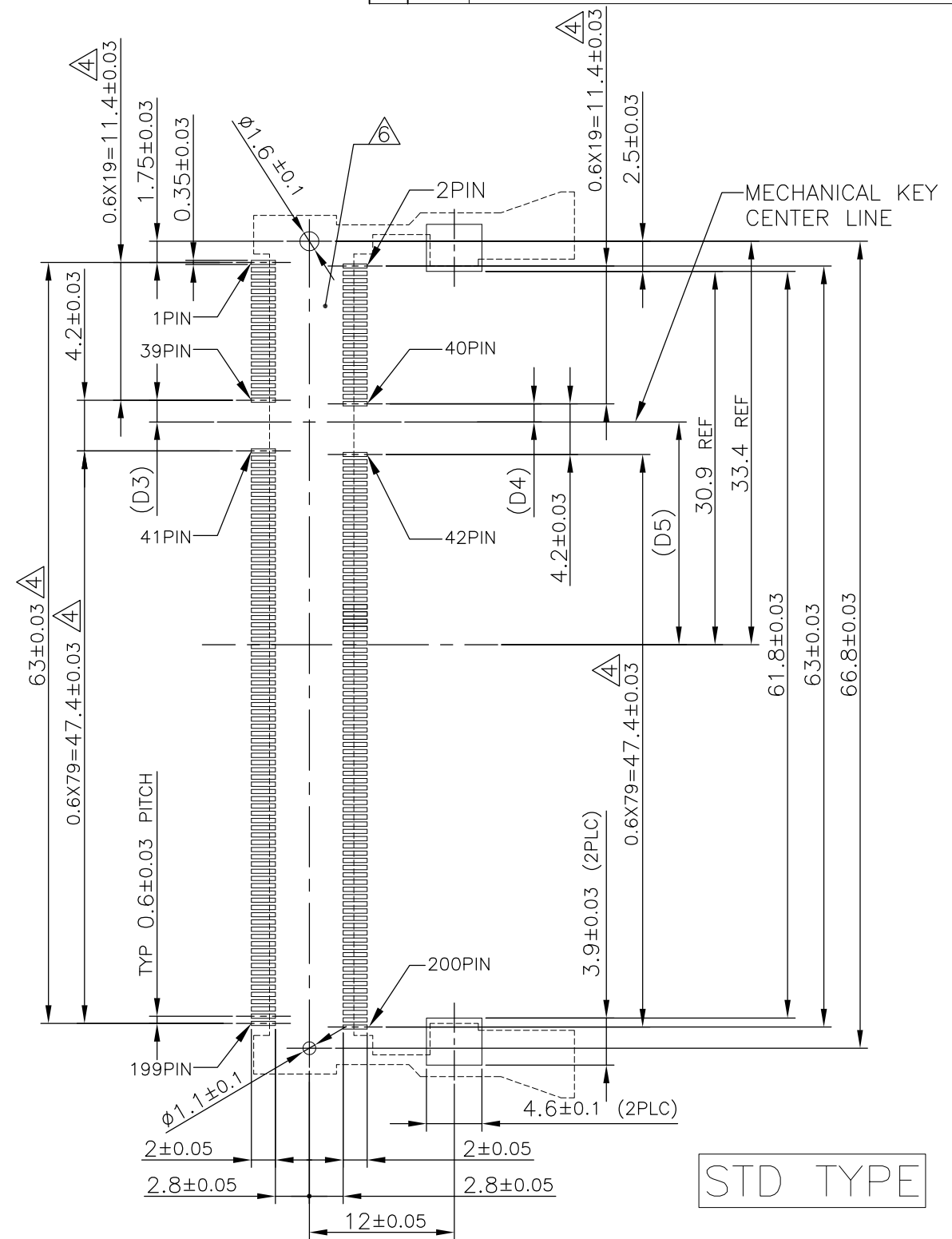

STD TYPE

1.8V	17.55	2.4	2.7
2.5V	18.45	1.5	1.8
POWER SUPPLY	D5	D4	D3

THIS DRAWING IS A CONTROLLED DOCUMENT.		DWN	<b>STE</b> TE Connectivity	
DIMENSIONS: MM		CHK		
TOLERANCES UNLESS OTHERWISE SPECIFIED:		APVD	NAME	
0 PLC ±		PRODUCT SPEC	DDR1 & DDR2 SODIMM SOCKET 0.6mm PITCH	
1 PLC ±		APPLICATION SPEC	200POS LOW PROFILE STANDARD TYPE	
2 PLC ±		WEIGHT	(LATCH DIRECT SOLDERING TYPE)	
3 PLC ±		CUSTOMER DRAWING	SIZE	RESTRICTED TO
4 PLC ±			A3	
ANGLES ±		CAGE CODE	DRAWING NO	
FINISH		00779	C-292406	
		SCALE	SHEET	REV
		2:1	2 OF 4	B3

THIS DRAWING IS UNPUBLISHED. RELEASED FOR PUBLICATION NOV. 2004. ALL RIGHTS RESERVED.

LOC ES	DIST	REVISIONS			
P	LTR	DESCRIPTION	DATE	DWN	APVD
	-	SEE SHEET 1	-	-	-

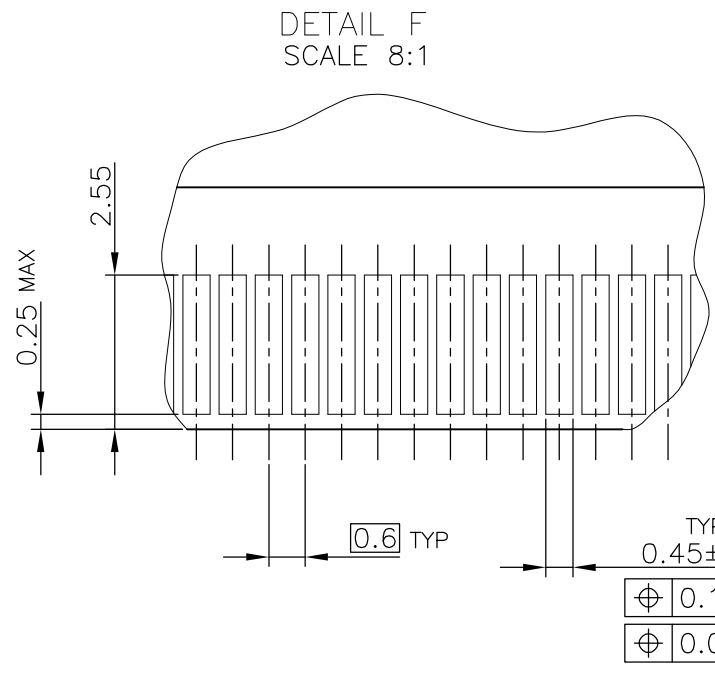
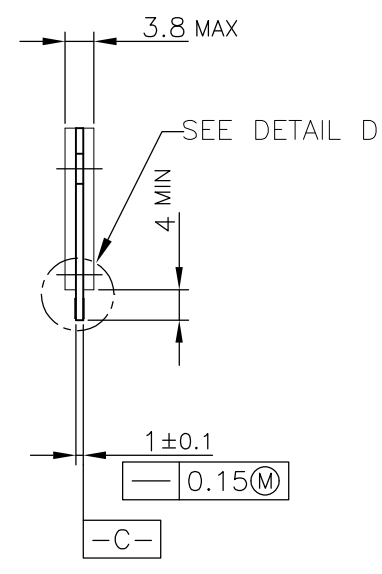
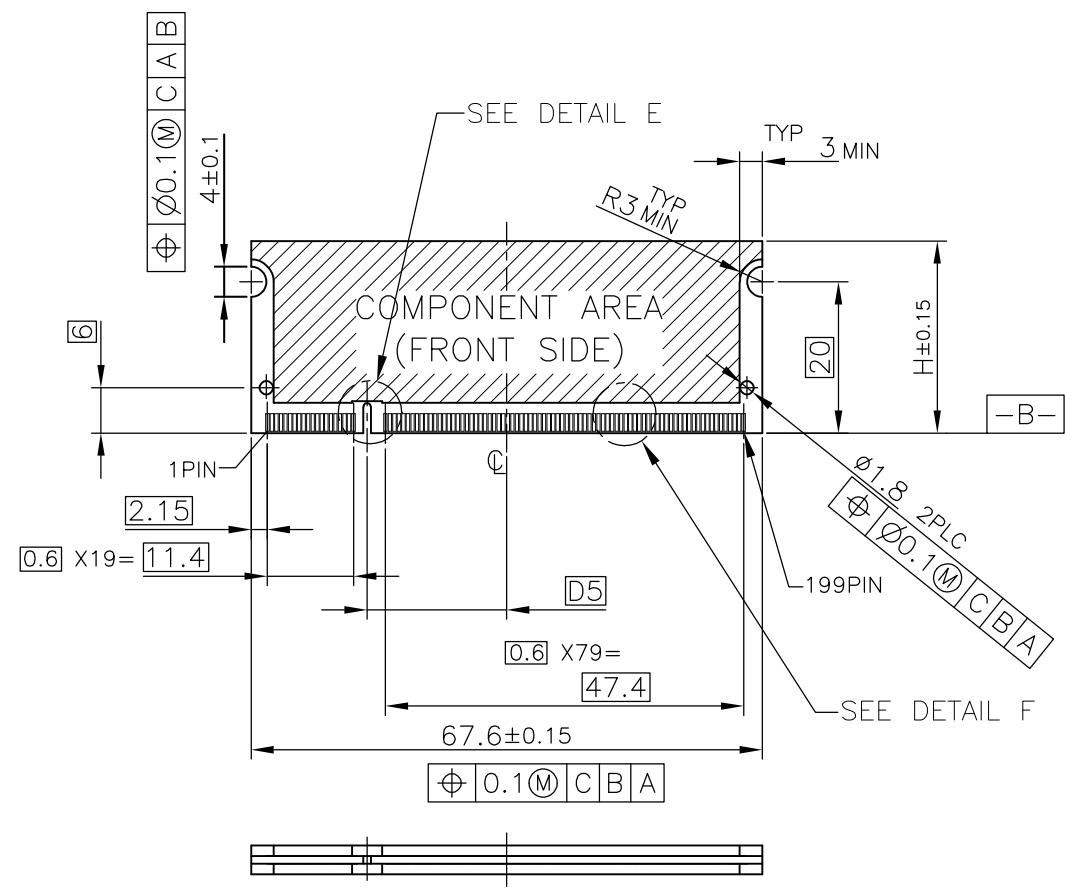

- (APPLIED TO SHEET 3)
1. TOLERANCES ON ALL DIMENSIONS ±0.15 UNLESS OTHERWISE SPECIFIED.
  2. P.C.BOARD THICKNESS APPLIES ACROSS TABS AND INCLUDES PLATING AND/OR METALIZATION.
  3. FINISH OF PAD : GOLD PLATING 0.00076 MIN. OVER Ni PLATING 0.002MIN.
- ⚠ NO BURR
- ⚠ CHAMFER 0.25 MAX x 45° IF EXIST.

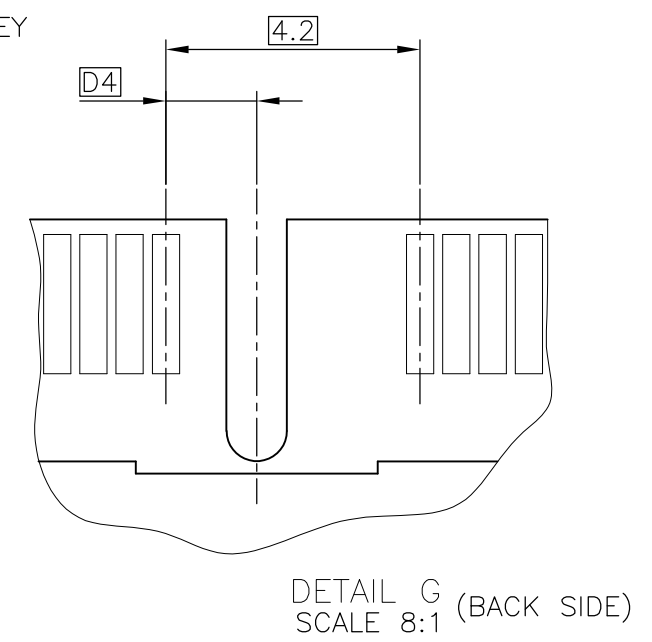
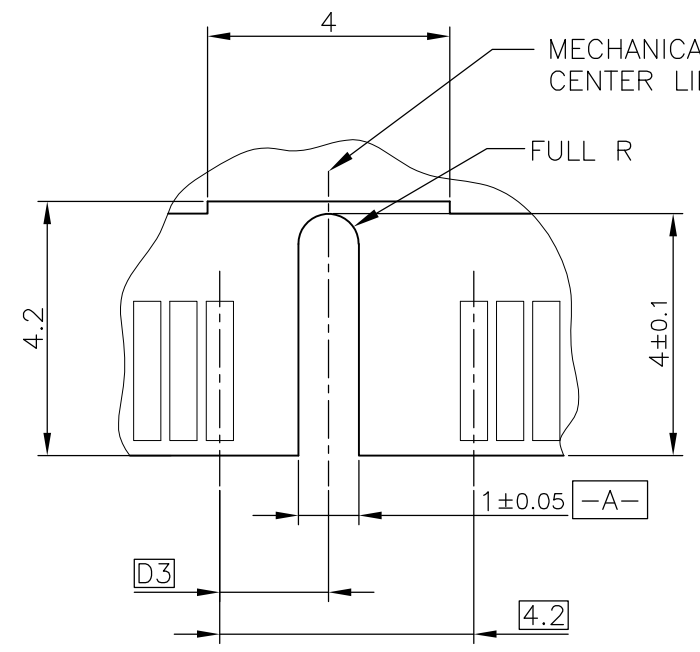
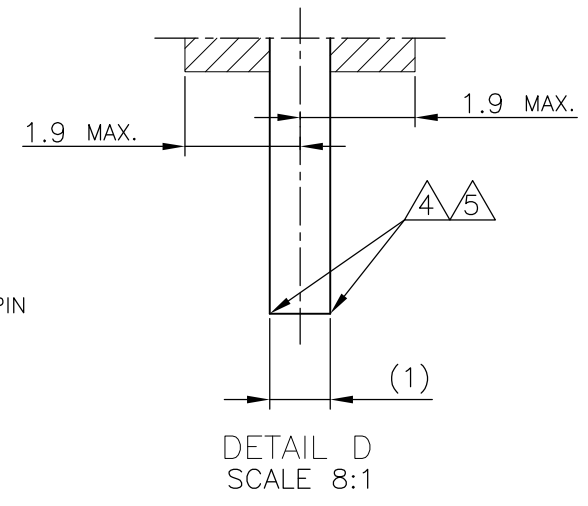
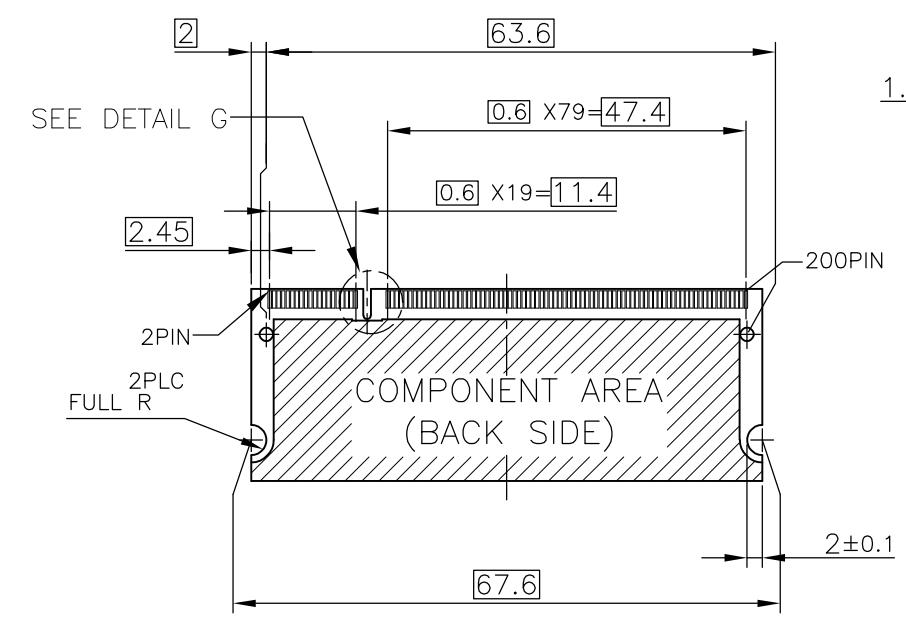

RECOMMENDED MATING P.C.B CONFIGURATION

31.75	1.8V	17.55	2.4	2.7
25.4	2.5V	18.45	1.5	1.8
H	POWER SUPPLY	D5	D4	D3

THIS DRAWING IS A CONTROLLED DOCUMENT.		DWN	TE Connectivity			
DIMENSIONS: MM		CHK				
TOLERANCES UNLESS OTHERWISE SPECIFIED:		APVD				
0 PLC ± 1 PLC ± 2 PLC ± 3 PLC ± 4 PLC ± ANGLES ± FINISH ±		NAME				
MATERIAL		PRODUCT SPEC	DDR1 & DDR2 SODIMM SOCKET 0.6mm PITCH 200POS LOW PROFILE STANDARD TYPE (LATCH DIRECT SOLDERING TYPE)			
		APPLICATION SPEC	SIZE	CAGE CODE	DRAWING NO	RESTRICTED TO
		WEIGHT	A3 00779 C-292406			
		CUSTOMER DRAWING	SCALE	SHEET	REV	
			2:1	3 OF 4	B3	

THIS DRAWING IS UNPUBLISHED. RELEASED FOR PUBLICATION NOV ,2004.  
 © COPYRIGHT 2004 By - ALL RIGHTS RESERVED.

LOC	DIST	REVISIONS			
P	LTR	DESCRIPTION	DATE	DWN	APVD
ES		SEE SHEET 1	-	-	-

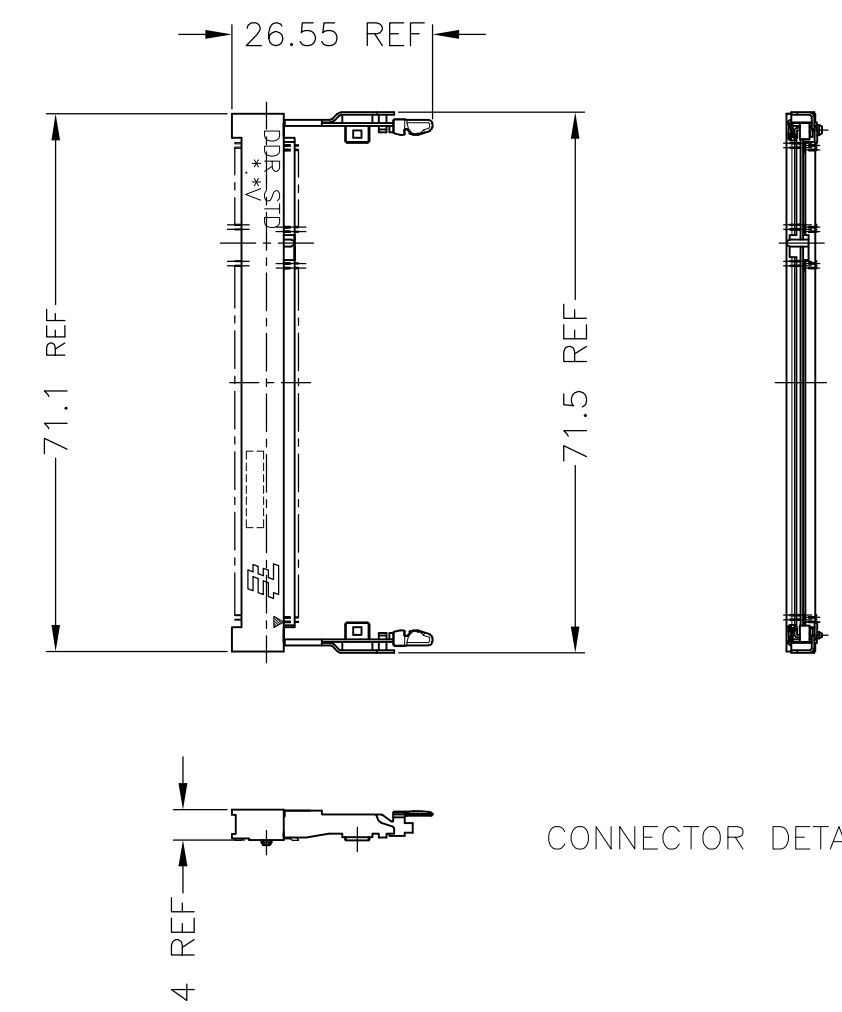
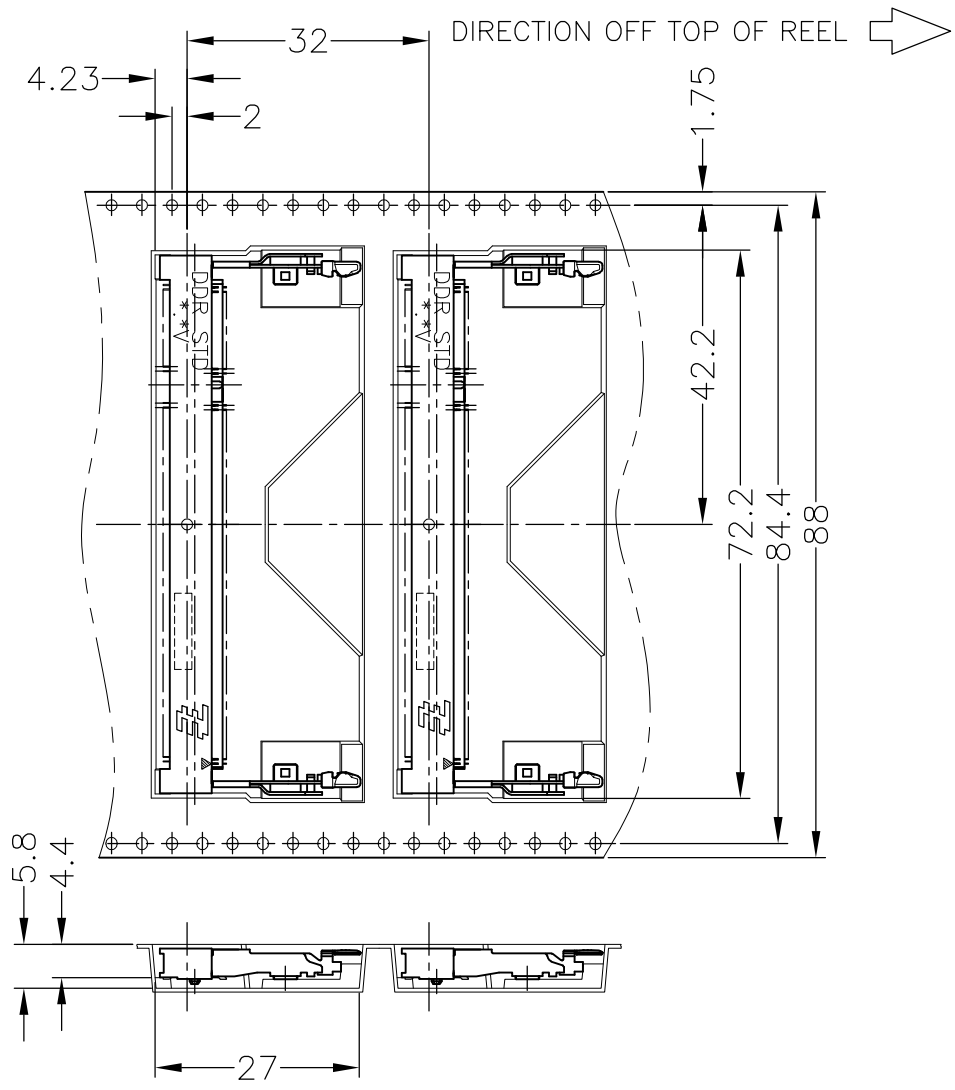

CONNECTOR DETAIL

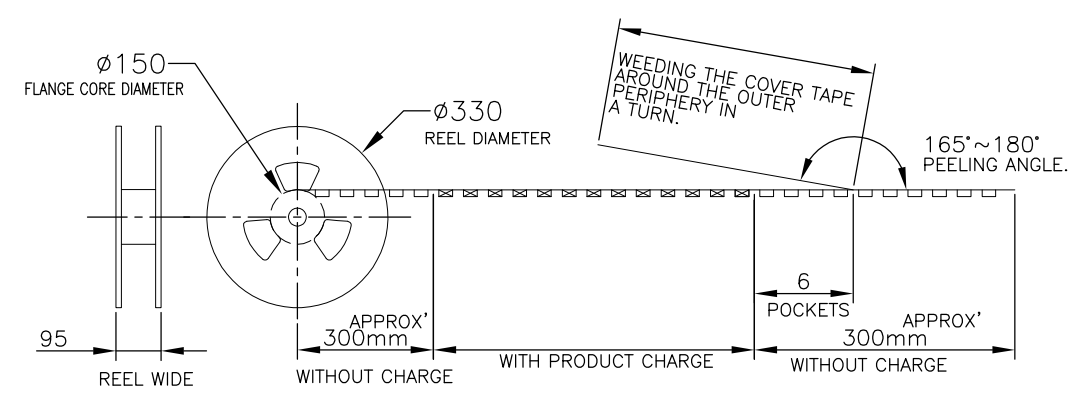

AVAILABLE	200EA/EMBOSS	292406-5
AVAILABLE	200EA/EMBOSS	292406-4
TOOLING STATUS	QTY	P/N

THIS DRAWING IS A CONTROLLED DOCUMENT.		DWN	TE Connectivity					
DIMENSIONS: MM		CHK				NAME		
TOLERANCES UNLESS OTHERWISE SPECIFIED: 0 PLC ± 1 PLC ± 2 PLC ± 3 PLC ± 4 PLC ± ANGLES ± FINISH ±		APVD				DDR1 & DDR2 SODIMM SOCKET 0.6mm PITCH 200POS LOW PROFILE STANDARD TYPE (LATCH DIRECT SOLDERING TYPE)		
MATERIAL		PRODUCT SPEC				SIZE	CAGE CODE	DRAWING NO
		APPLICATION SPEC	A3 00779 C-292406					
		WEIGHT	RESTRICTED TO					
		CUSTOMER DRAWING	SCALE	SHEET	REV			
			1:1	4 OF 4	B3			

Компания «Life Electronics» занимается поставками электронных компонентов импортного и отечественного производства от производителей и со складов крупных дистрибьюторов Европы, Америки и Азии.

С конца 2013 года компания активно расширяет линейку поставок компонентов по направлению коаксиальный кабель, кварцевые генераторы и конденсаторы (керамические, пленочные, электролитические), за счёт заключения дистрибьюторских договоров

Мы предлагаем:

- Конкурентоспособные цены и скидки постоянным клиентам.
- Специальные условия для постоянных клиентов.
- Подбор аналогов.
- Поставку компонентов в любых объемах, удовлетворяющих вашим потребностям.
- Приемлемые сроки поставки, возможна ускоренная поставка.
- Доставку товара в любую точку России и стран СНГ.
- Комплексную поставку.
- Работу по проектам и поставку образцов.
- Формирование склада под заказчика.
- Сертификаты соответствия на поставляемую продукцию (по желанию клиента).
- Тестирование поставляемой продукции.
- Поставку компонентов, требующих военную и космическую приемку.
- Входной контроль качества.
- Наличие сертификата ISO.

В составе нашей компании организован Конструкторский отдел, призванный помогать разработчикам, и инженерам.

Конструкторский отдел помогает осуществить:

- Регистрацию проекта у производителя компонентов.
- Техническую поддержку проекта.
- Защиту от снятия компонента с производства.
- Оценку стоимости проекта по компонентам.
- Изготовление тестовой платы монтаж и пусконаладочные работы.



Тел: +7 (812) 336 43 04 (многоканальный)

Email: [org@lifeelectronics.ru](mailto:org@lifeelectronics.ru)