

High Voltage $I_o=100\text{mA}$ Low Dropout Regulator

■ GENERAL DESCRIPTION

The NJW4183 is a high voltage and low current consumption low dropout regulator using BCD process.

It have lineup as A version(built-in ON/OFF function type) and B version.(without ON/OFF function type)

NJW4183 is mounted to SOT-89-3/5, TO-252-3/5 package and corresponded to Low ESR capacitor (MLCC).

It is suitable for a Car accessory, battery equipment and various applications.

■ PACKAGE OUTLINE



NJW4183U2

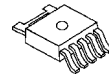

NJW4183DL3



NJW4183U3

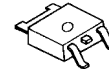

NJW4183DL1

■ FEATURES

- Wide Operating Voltage Range 4.0V to 35V
- Low Current Consumption 18 μ A (A version.)
15 μ A (B version.)
- Correspond to Low ESR capacitor (MLCC)
- Output Current $I_o(\text{min.})=100\text{mA}$
- Output Voltage Range V_o : 2.0V to 5.0V
- High Precision Output $V_o \pm 1.0\%$
- ON / OFF Function (Apply only the A version.)
- Thermal Overload Protection
- Over Current Protection
- Reverse Current Protection
- Package Outline A ver. : SOT-89-5 TO-252-5
B ver. : SOT-89-3 TO-252-3

■ PRODUCT CLASSIFICATION

Device Name	Version	ON/OFF Function	Package
NJM4183U2-xxA	A	Yes	SOT-89-5
NJM4183DL3-xxA	A	Yes	TO-252-5
NJM4183U3-xxB	B	-	SOT-89-3
NJW4183DL1-xxB	B	-	TO-252-3

xx=Output Voltage ex) 33=3.3V 05=5.0V

■ PIN CONFIGURATION

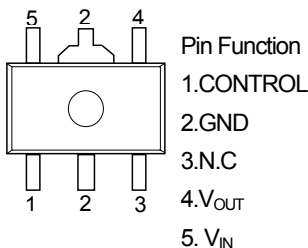

NJW4183U2-A

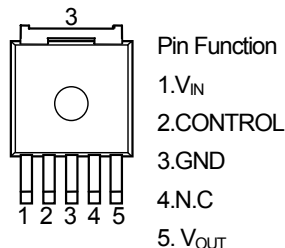

NJW4183DL3-A

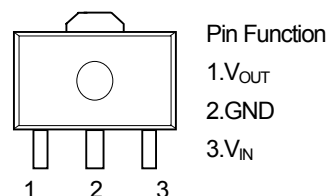

NJW4183U3-B

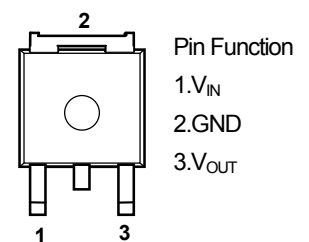

NJW4183DL1-B

NJW4183

■ BLOCK DIAGRAM

• A version

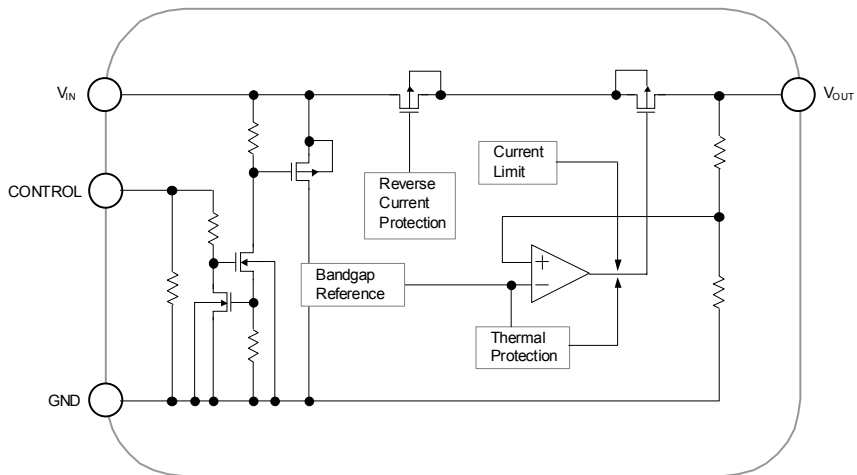

• B version

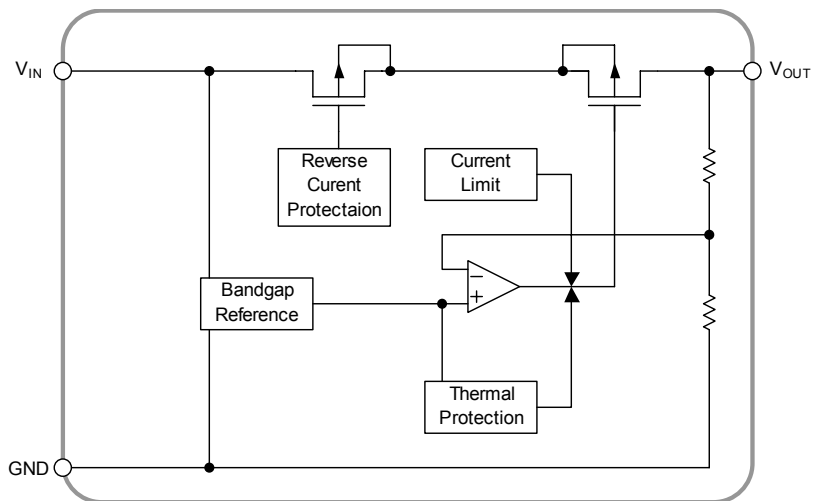

■ OUTPUT VOLTAGE RANK LIST

• A version

SOT-89-5

TO-252-5

Device Name	V _{OUT}	Device Name	V _{OUT}
NJW4183U2-33A	3.3V	NJW4183DL3-33A	3.3V
NJW4183U2-05A	5.0V	NJW4183DL3-05A	5.0V

• B version

SOT-89-3

TO-252-3

Device Name	V _{OUT}	Device Name	V _{OUT}
NJW4183U3-33B	3.3V	NJW4183DL1-33B	3.3V
NJW4183U3-05B	5.0V	NJW4183DL1-05B	5.0V

■ ABSOLUTE MAXIMUM RATINGS (Ta=25°C)

PARAMETER	SYMBOL	RATINGS	UNIT	
Input Voltage	V _{IN}	-0.3 to +40	V	
Control Voltage(*1)	V _{CONT}	-0.3 to +40	V	
Output Voltage	V _{OUT}	-0.3 to +7	V	
Power Dissipation	P _D	SOT-89-3/5	625(*2) 2400(*3)	mW
		TO-252-3/5	1190(*2) 3125(*3)	
Junction Temperature	T _J	-40 to +150	°C	
Operating Temperature	Topr	-40 to +85	°C	
Storage Temperature	Tstg	-40 to +150	°C	

(*1): Apply only the A version.

(*2): Mounted on glass epoxy board. (76.2 × 114.3 × 1.6mm:based on EIA/JDEC standard size, 2Layers, Cu area 100mm²)

(*3): Mounted on glass epoxy board. (76.2 × 114.3 × 1.6mm:based on EIA/JDEC standard, 4Layers)

(For 4Layers: Applying 74.2 × 74.2mm inner Cu area and a thermal via hole to a board based on JEDEC standard JESD51-5)

■ ELECTRICAL CHARACTERISTICS

(Unless otherwise noted, V_O = 3V: V_{IN}=V_O + 1V, C_{IN}=1μF, C_O=2.2μF, Ta=25°C

V_O < 3V: V_{IN}=4V, C_{IN}=1μF, C_O=2.2μF (V_O = 2.5 : C_O=4.7μF), Ta=25°C)

PARAMETER	SYMBOL	TEST CONDITION	MIN.	TYP.	MAX.	UNIT	
Output Voltage	V _O	I _O = 30mA	-1.0%	-	+1.0%	V	
Quiescent Current	I _Q	A version I _O = 0mA, except I _{CONT}	-	18	30	μA	
		B version I _O = 0mA	-	15	27		
Quiescent Current at Control OFF(*4)	I _Q	V _O × 0.9	100	-	-	mA	
Output Current	I _{Q(OFF)}	V _{CONT} =0V	-	-	1	μA	
Line Regulation	ΔV _O /ΔV _{IN}	V _{IN} = V _O + 1V to 35V, I _O = 30mA (V _O ≥ 3V), V _{IN} = 4V to 35V, I _O = 30mA (V _O < 3V)	-	-	0.05	%/V	
Load Regulation	ΔV _O /ΔI _O	I _O = 0mA to 100mA	-	-	0.018	%/mA	
Ripple Rejection	RR	V _{IN} =V _O +2V, ein=50mVrms f=1kHz, I _O = 10mA	V _O =3.3V	-	45	-	dB
			V _O =5.0V	-	43	-	
Dropout Voltage(*5)	ΔV _{IO}	I _O =60mA	-	0.16	0.26	V	
Control Current(*4)	I _{CONT}	V _{CONT} =1.6V	-	0.5	3	μA	
Control Voltage for ON-state(*4)	V _{CONT(ON)}		1.6	-	-	V	
Control Voltage for OFF-state(*4)	V _{CONT(OFF)}		-	-	0.6	V	
Average Temperature Coefficient of Output Voltage	ΔV _O /ΔTa	Ta=0 to 85°C, I _O = 30mA	-	±50	-	ppm/°C	

(*4): Apply only the A version.

(*5): The output voltage excludes under 3.8V.

The above specification is a common specification for all output voltages.

Therefore, it may be different from the individual specification for a specific output voltage.

■ POWER DISSIPATION vs. AMBIENT TEMPERATURE

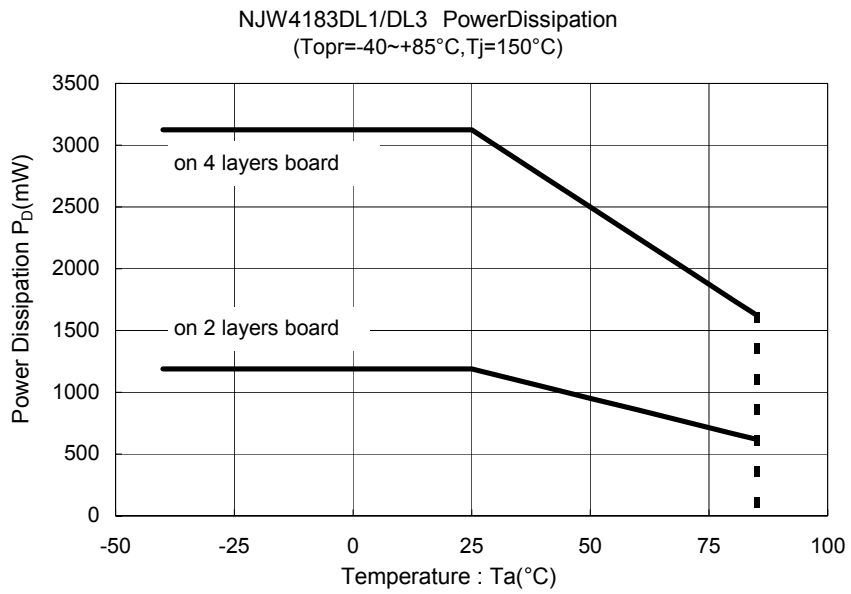
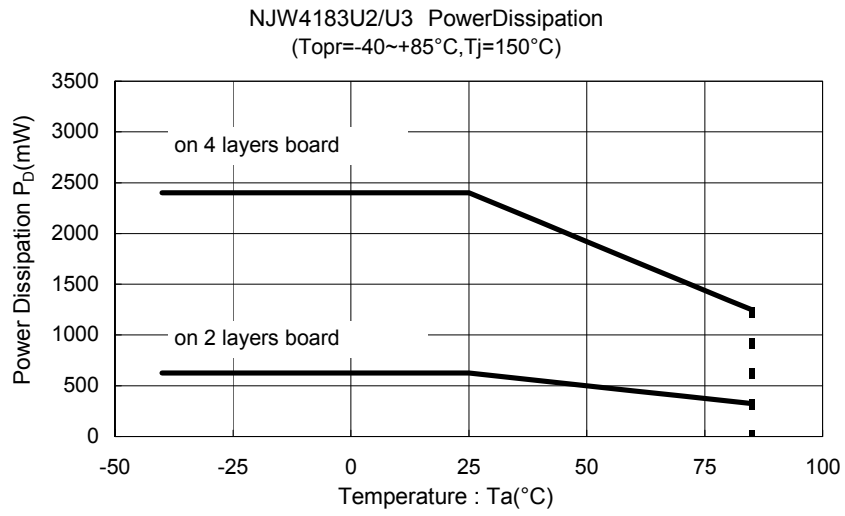

■ TEST CIRCUIT

• A version

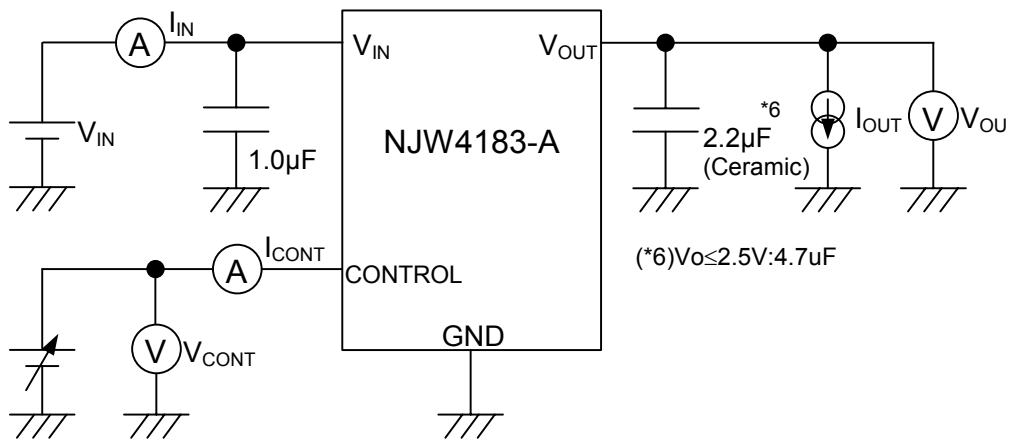

• B version

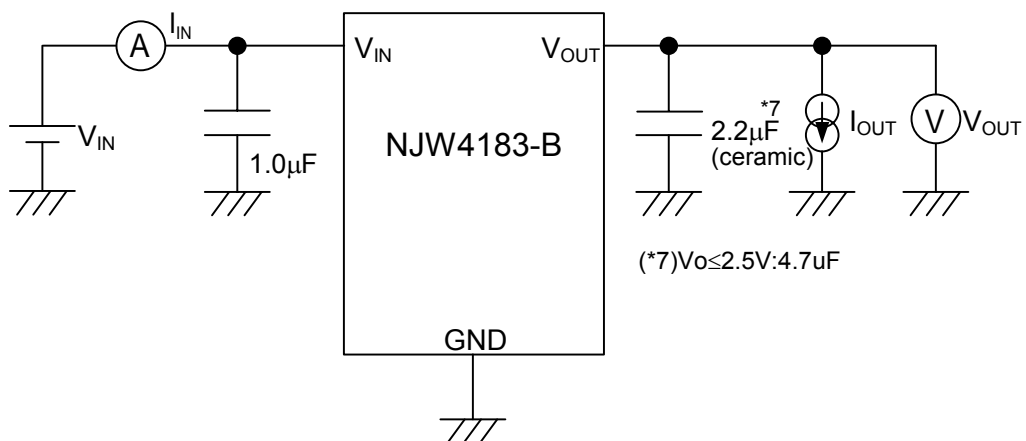

NJW4183

■ TYPICAL APPLICATION

• A version

① In the case where ON/OFF Control is not required

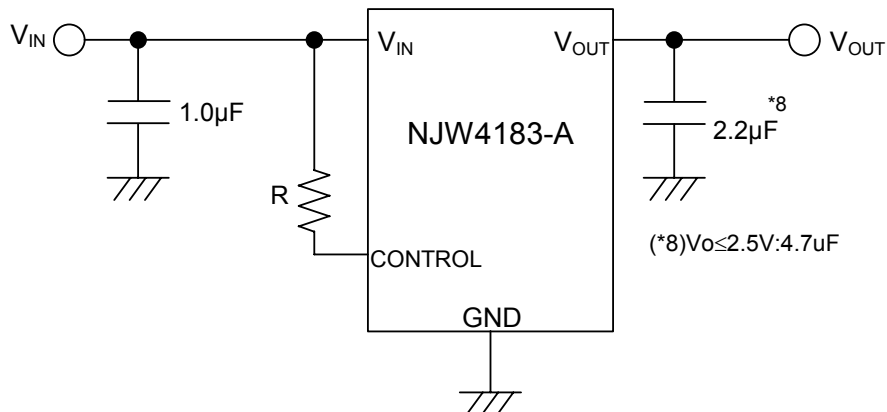

Connect control pin to V_{IN} pin

② In use of ON/OFF CONTROL

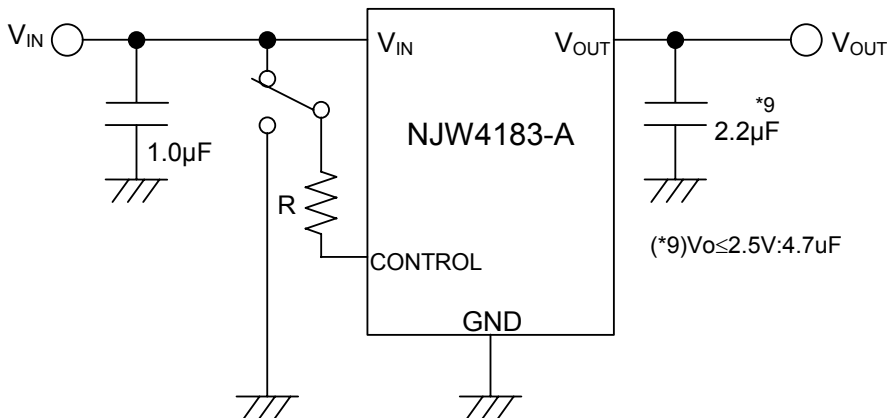

State of control pin:

- “H” → output is enabled.
- “L” or “open” → output is disabled.

• B version

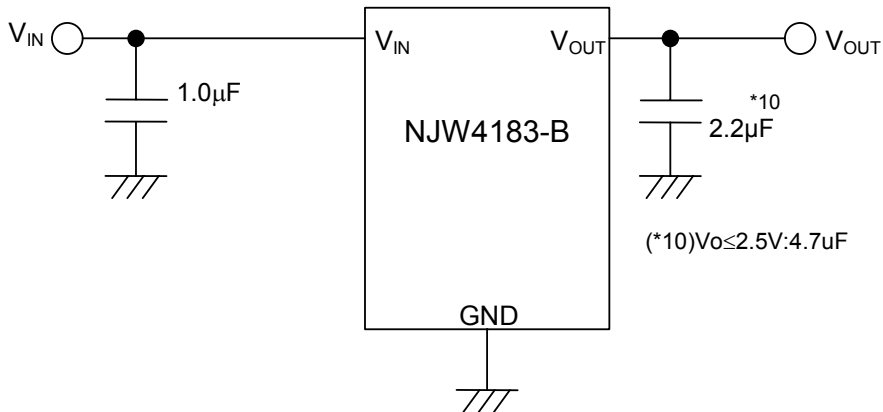

*In the case of using a resistance "R" between V_{IN} and control.

If this resistor is inserted, it can reduce the control current when the control voltage is high.

The applied voltage to control pin should set to consider voltage drop through the resistor "R" and the minimum control voltage for ON-state.

The $V_{CONT(ON)}$ and I_{CONT} have temperature dependence as shown in the "Control Current vs. Temperature" and "Control Voltage vs. Temperature" characteristics. Therefore, the resistance "R" should be selected to consider the temperature characteristics.

*Input Capacitor C_{IN}

Input Capacitor C_{IN} is required to prevent oscillation and reduce power supply ripple for applications when high power supply impedance or a long power supply line.

Therefore, use the recommended C_{IN} value (refer to conditions of ELECTRIC CHARACTERISTIC) or larger and should connect between GND and V_{IN} as shortest path as possible to avoid the problem.

*Output Capacitor C_O

Output capacitor (C_O) will be required for a phase compensation of the internal error amplifier.

The capacitance and the equivalent series resistance (ESR) influence to stable operation of the regulator.

Use of a smaller C_O may cause excess output noise or oscillation of the regulator due to lack of the phase compensation.

On the other hand, Use of a larger C_O reduces output noise and ripple output, and also improves output transient response when rapid load change.

Therefore, use the recommended C_O value (refer to conditions of ELECTRIC CHARACTERISTIC) or larger and should connect between GND and V_{OUT} as shortest path as possible for stable operation

The recommended capacitance depends on the output voltage rank. Especially, low voltage regulator requires larger C_O value.

In addition, you should consider varied characteristics of capacitor (a frequency characteristic, a temperature characteristic, a DC bias characteristic and so on) and unevenness peculiar to a capacitor supplier enough.

When selecting C_O , recommend that have withstand voltage margin against output voltage and superior temperature characteristic.

TYPICAL CHARACTERISTICS

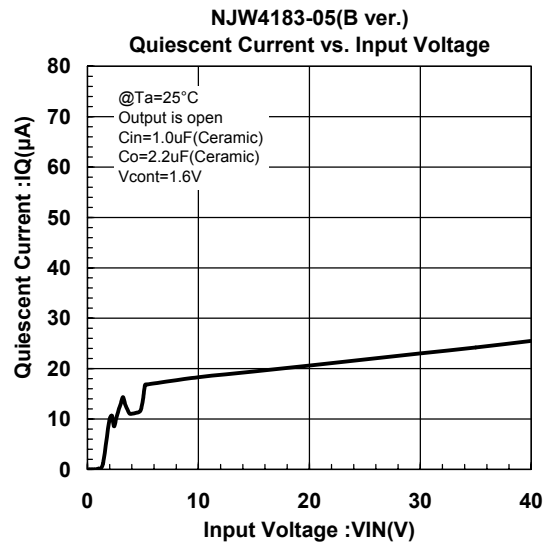
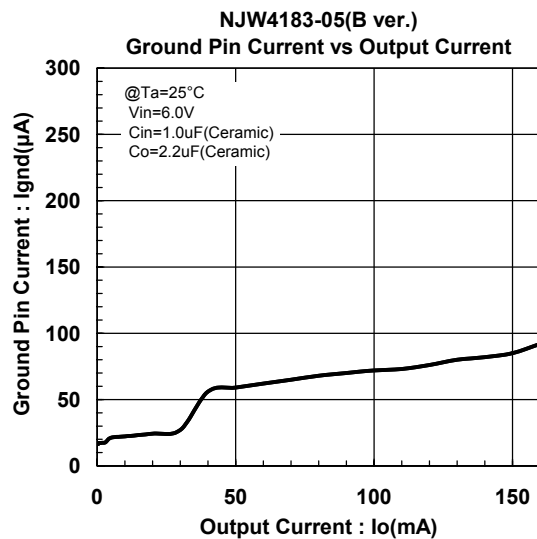
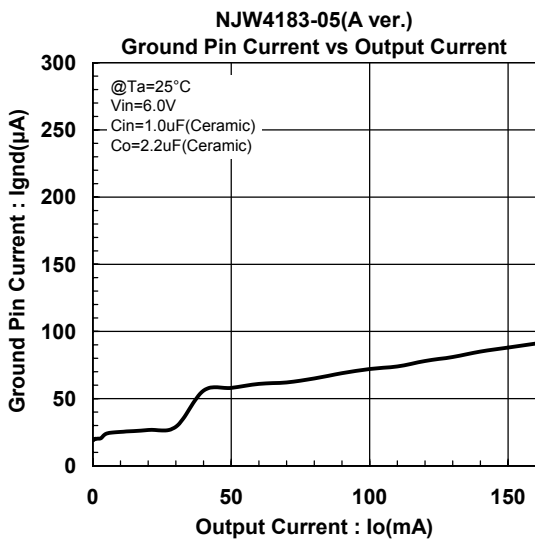
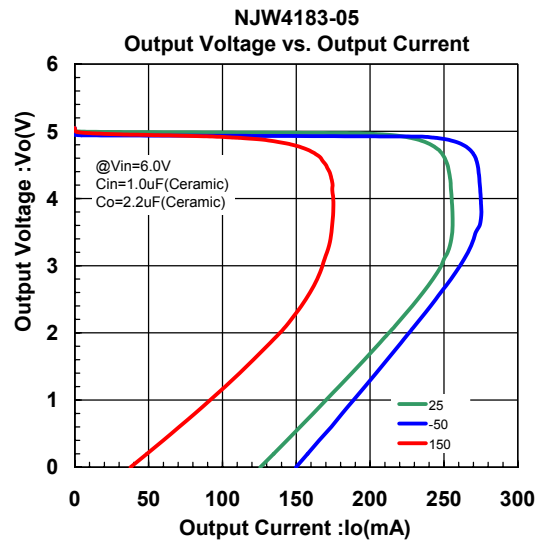
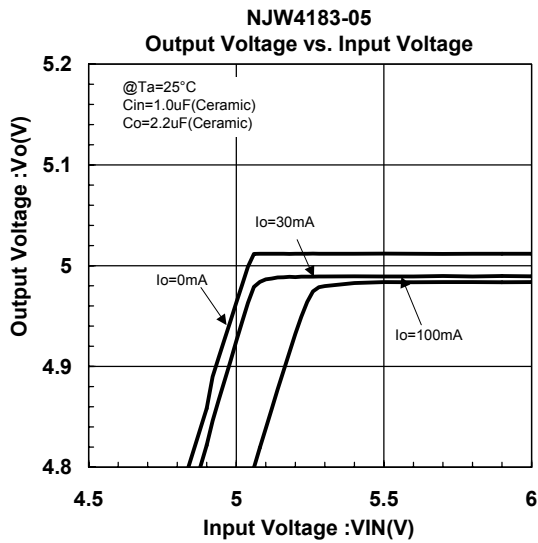

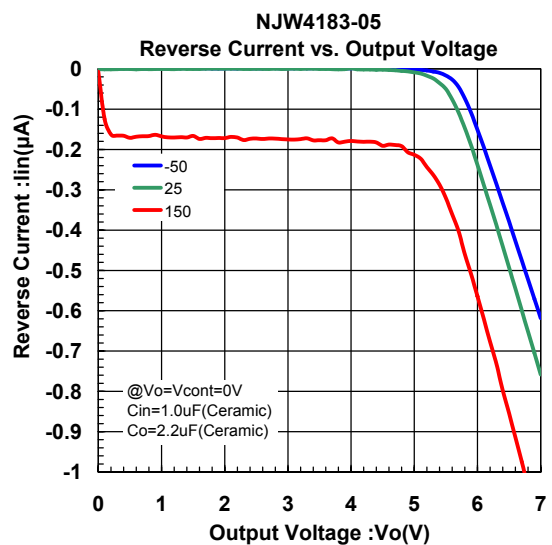
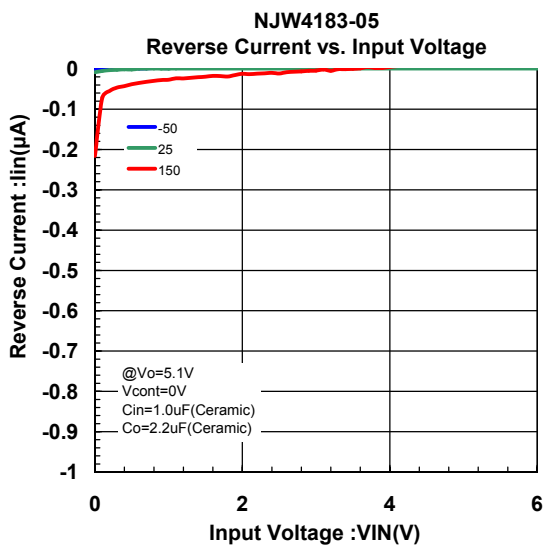
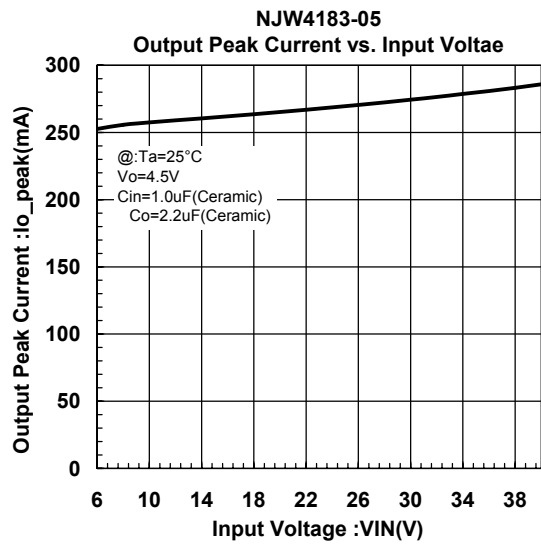
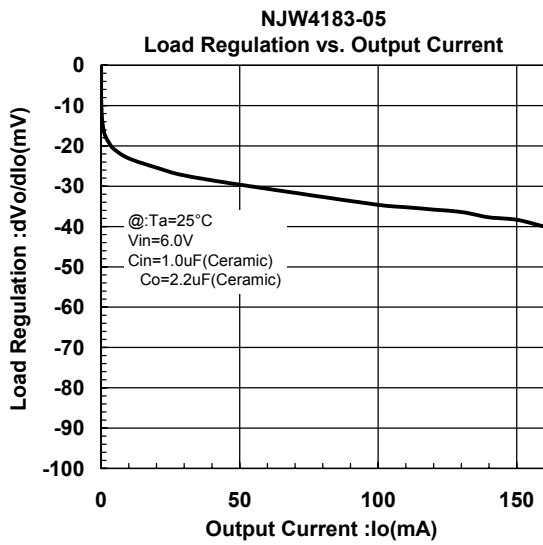
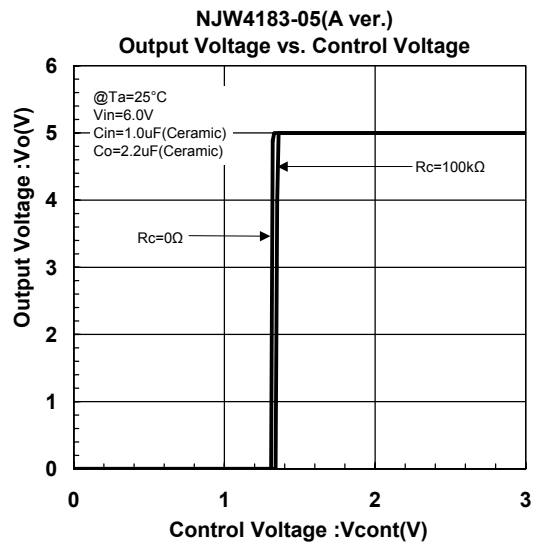
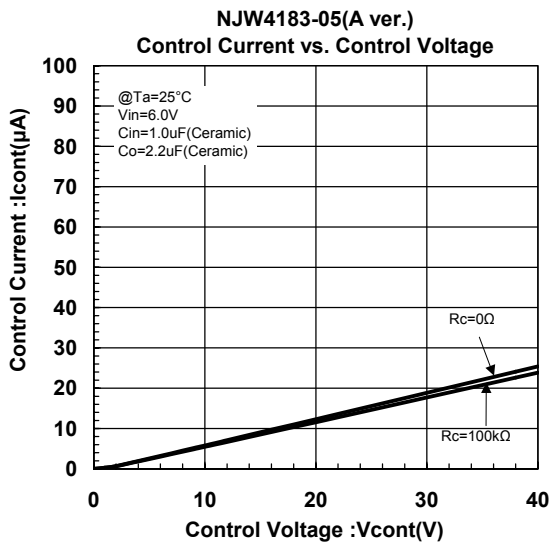

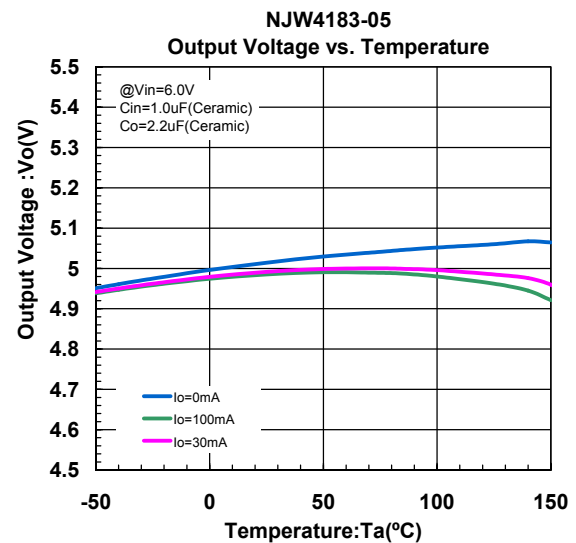
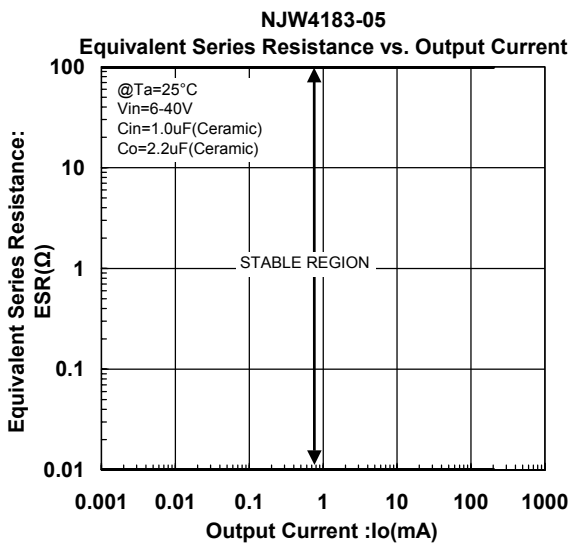
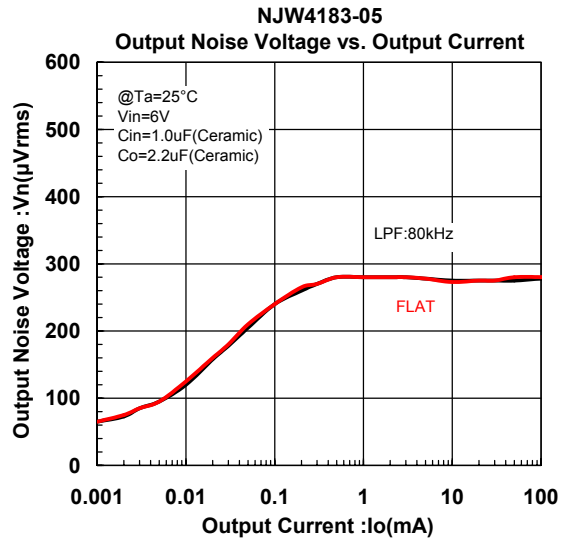
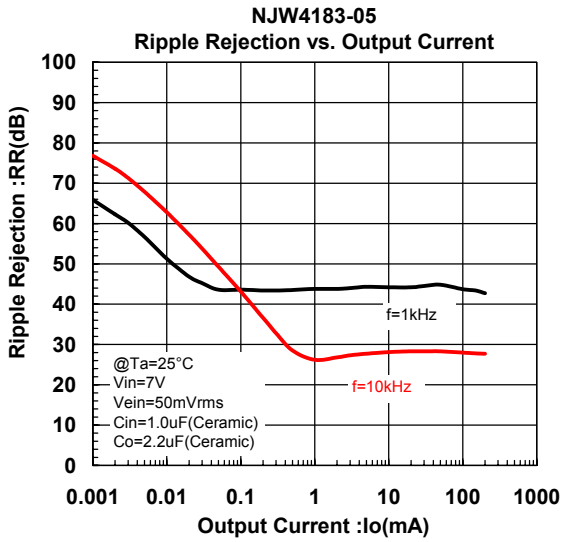
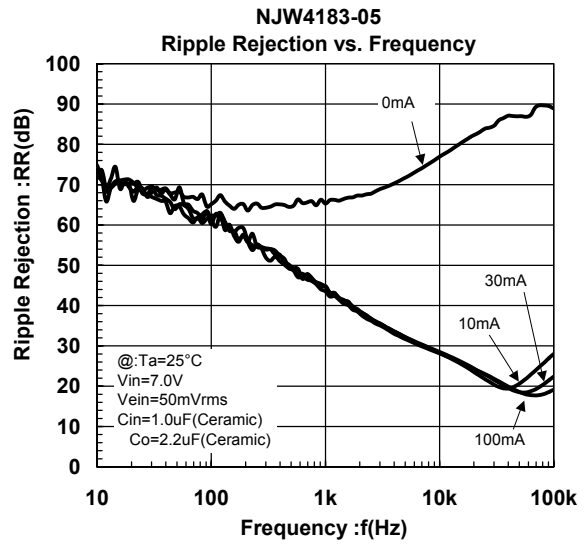
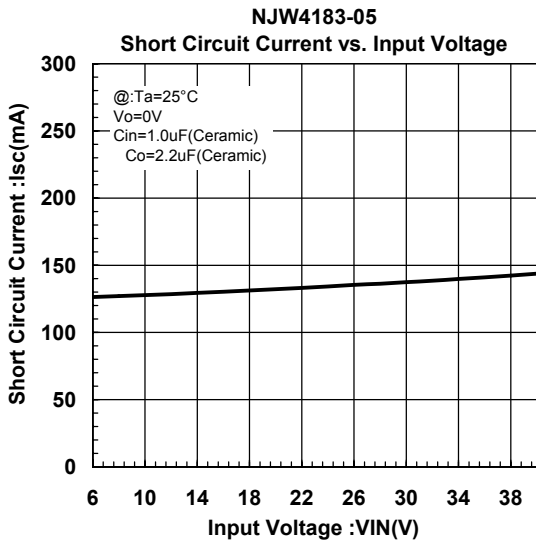

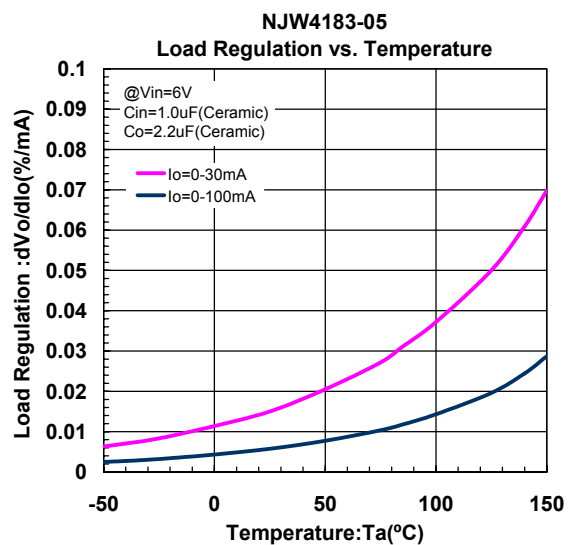
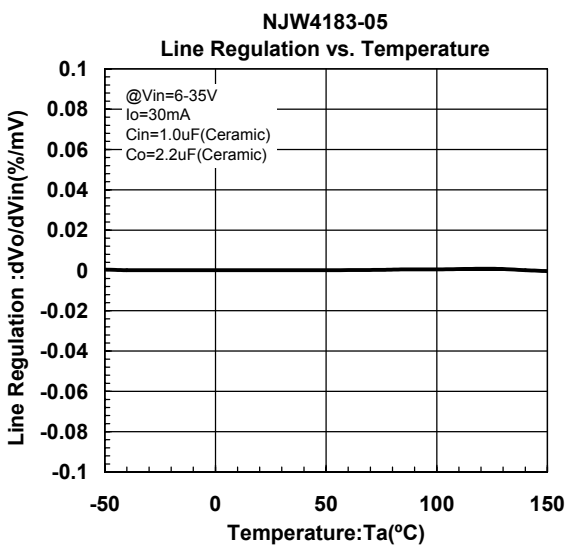
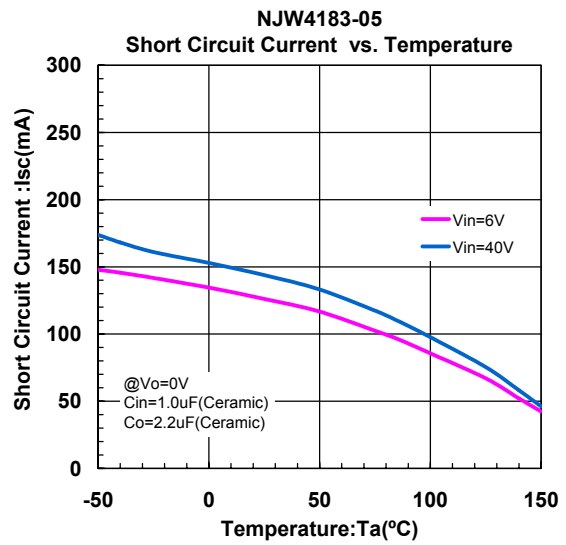
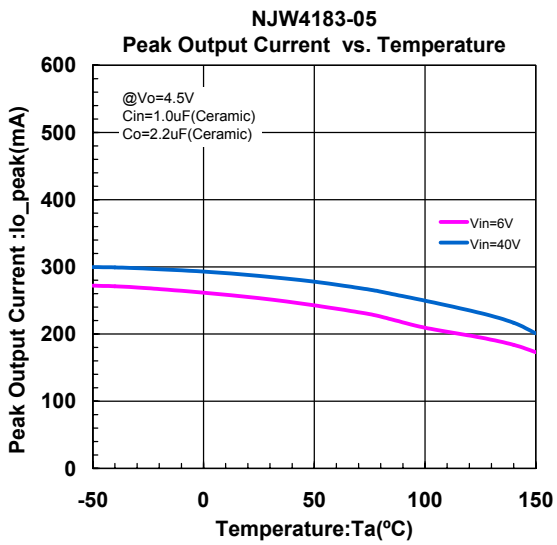
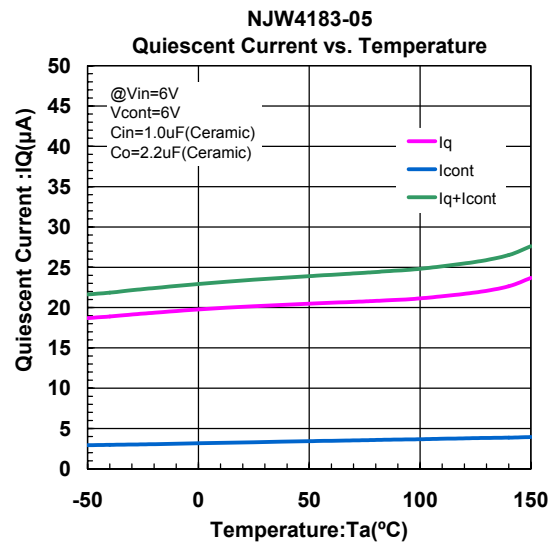
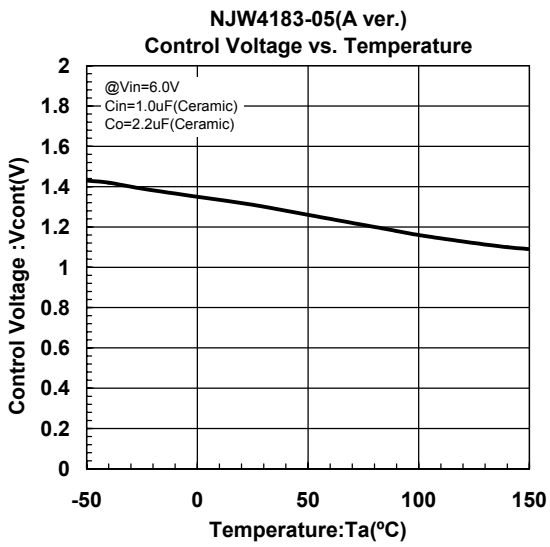

NJW4183

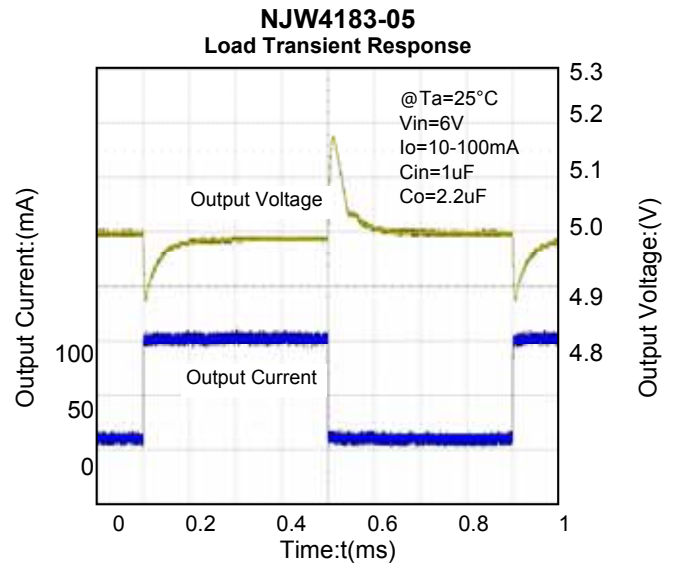
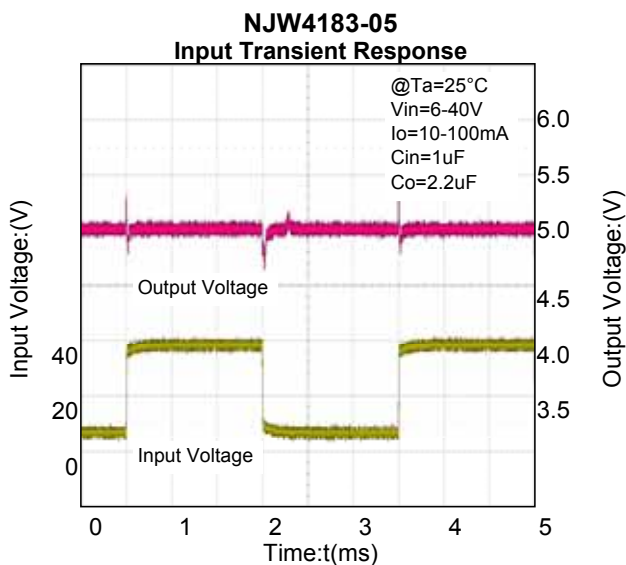
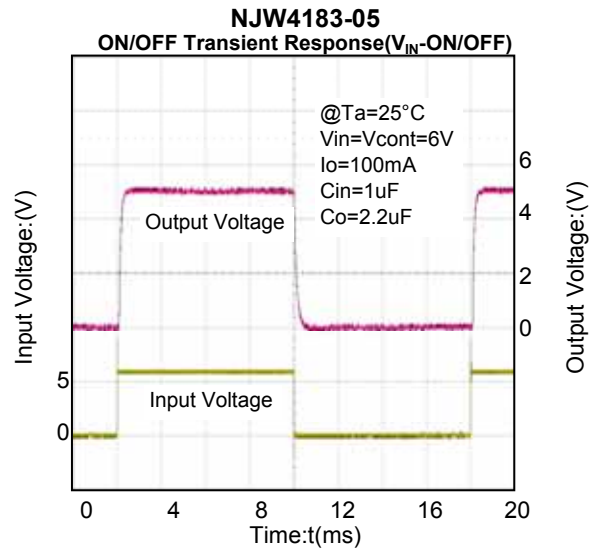
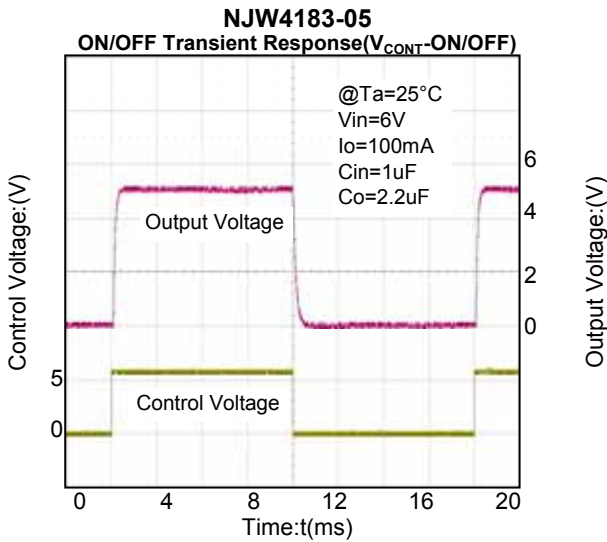
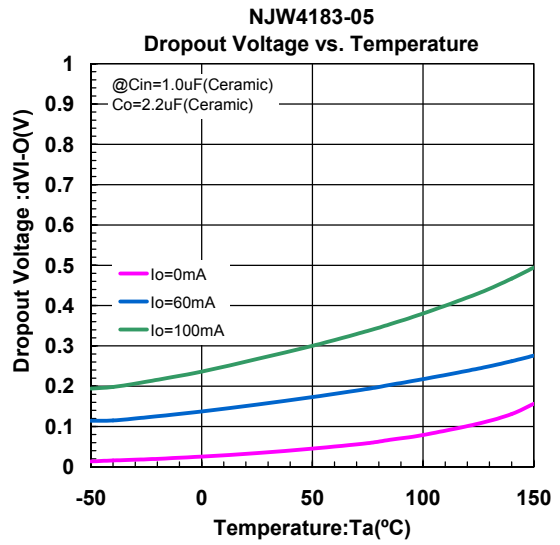
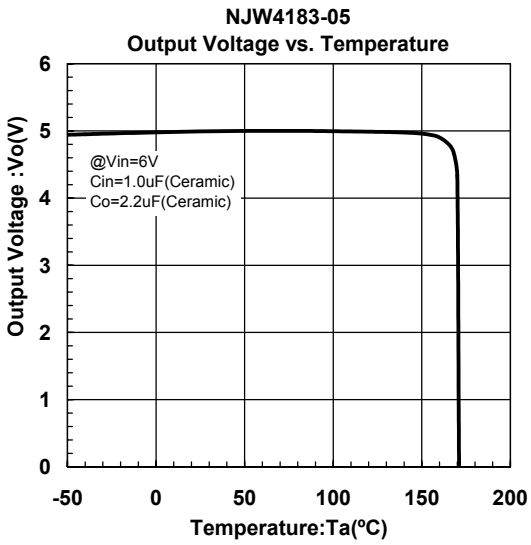

[CAUTION]

The specifications on this databook are only given for information, without any guarantee as regards either mistakes or omissions. The application circuits in this databook are described only to show representative usages of the product and not intended for the guarantee or permission of any right including the industrial rights.

Mouser Electronics

Authorized Distributor

Click to View Pricing, Inventory, Delivery & Lifecycle Information:

[NJR:](#)

[NJW4183U3](#)

Компания «Life Electronics» занимается поставками электронных компонентов импортного и отечественного производства от производителей и со складов крупных дистрибьюторов Европы, Америки и Азии.

С конца 2013 года компания активно расширяет линейку поставок компонентов по направлению коаксиальный кабель, кварцевые генераторы и конденсаторы (керамические, пленочные, электролитические), за счёт заключения дистрибьюторских договоров

Мы предлагаем:

- Конкурентоспособные цены и скидки постоянным клиентам.
- Специальные условия для постоянных клиентов.
- Подбор аналогов.
- Поставку компонентов в любых объемах, удовлетворяющих вашим потребностям.
- Приемлемые сроки поставки, возможна ускоренная поставка.
- Доставку товара в любую точку России и стран СНГ.
- Комплексную поставку.
- Работу по проектам и поставку образцов.
- Формирование склада под заказчика.
- Сертификаты соответствия на поставляемую продукцию (по желанию клиента).
- Тестирование поставляемой продукции.
- Поставку компонентов, требующих военную и космическую приемку.
- Входной контроль качества.
- Наличие сертификата ISO.

В составе нашей компании организован Конструкторский отдел, призванный помогать разработчикам, и инженерам.

Конструкторский отдел помогает осуществить:

- Регистрацию проекта у производителя компонентов.
- Техническую поддержку проекта.
- Защиту от снятия компонента с производства.
- Оценку стоимости проекта по компонентам.
- Изготовление тестовой платы монтаж и пусконаладочные работы.



Тел: +7 (812) 336 43 04 (многоканальный)
Email: org@lifeelectronics.ru