



USB2512A



USB 2.0 Hi-Speed 2-Port Hub Controller

PRODUCT FEATURES

Data Brief

General Description

The SMSC 2-Port Hub is a low power, OEM configurable, STT (Single transaction translator) hub controller IC with 2 downstream ports for embedded USB solutions. The 2-port hub is fully compliant with the USB 2.0 Specification and will attach to an upstream port as a Full-Speed Hub or as a Full-/Hi-Speed Hub. The 2-Port Hub supports Low-Speed, Full-Speed, and Hi-Speed (if operating as a Hi-Speed Hub) downstream devices on all of the enabled downstream ports.

General Features

- Hub Controller IC with 2 downstream ports
- Enhanced OEM configuration options available through either a single serial I²C EEPROM, or SMBus Slave Port
- 36-pin (6x6mm) QFN lead-free, RoHS compliant package

Hardware Features

- Low power operation
- Full Power Management with individual or ganged power control of each downstream port
- On-chip Power On Reset (POR)
- Internal 1.8V Voltage Regulator
- Fully integrated USB termination and Pull-up/Pull-down resistors
- On Board 24MHz Crystal Driver, Resonator or External 24MHz clock input
- Enhanced EMI rejection and ESD protection performance

OEM Selectable Features

- Customizable Vendor ID, Product ID, and Device ID
- Select whether the hub is part of a compound device (When any downstream port is permanently hardwired to a USB peripheral device, the hub is part of a compound device)
- Flexible port mapping and disable sequence. Ports can be disabled/reordered in any order to support multiple product SKUs. Hub will automatically reorder the remaining ports to match the Host controller's numbering scheme.
- Programmable USB differential-pair pin location. Ease PCB layout by aligning USB signal lines directly to connectors
- Programmable USB signal drive strength. Recover USB signal integrity due to compromised system environment using 2-level driving strength resolution

- Select the presence of a permanently hardwired USB peripheral device on a port by port basis
- Configure the delay time for filtering the over-current sense inputs
- Configure the delay time for turning on downstream port power
- Indicate the maximum current that the 2-port hub consumes from the USB upstream port
- Indicate the maximum current required for the hub controller
- Pin Selectable Options for Default Configuration
 - Select Downstream Ports as Non-Removable Ports

Applications

- LCD monitors and TVs
- Multi-function USB peripherals
- PC mother boards
- Set-top boxes, DVD players, DVR/PVR
- Printers and scanners
- PC media drive bay
- Portable hub boxes
- Mobile PC docking
- Embedded systems

ORDER NUMBER:**USB2512A-AEZG FOR 36 PIN, QFN LEAD-FREE ROHS COMPLIANT PACKAGE**

80 ARKAY DRIVE, HAUPPAUGE, NY 11788 (631) 435-6000, FAX (631) 273-3123

Copyright © 2008 SMSC or its subsidiaries. All rights reserved.

Circuit diagrams and other information relating to SMSC products are included as a means of illustrating typical applications. Consequently, complete information sufficient for construction purposes is not necessarily given. Although the information has been checked and is believed to be accurate, no responsibility is assumed for inaccuracies. SMSC reserves the right to make changes to specifications and product descriptions at any time without notice. Contact your local SMSC sales office to obtain the latest specifications before placing your product order. The provision of this information does not convey to the purchaser of the described semiconductor devices any licenses under any patent rights or other intellectual property rights of SMSC or others. All sales are expressly conditional on your agreement to the terms and conditions of the most recently dated version of SMSC's standard Terms of Sale Agreement dated before the date of your order (the "Terms of Sale Agreement"). The product may contain design defects or errors known as anomalies which may cause the product's functions to deviate from published specifications. Anomaly sheets are available upon request. SMSC products are not designed, intended, authorized or warranted for use in any life support or other application where product failure could cause or contribute to personal injury or severe property damage. Any and all such uses without prior written approval of an Officer of SMSC and further testing and/or modification will be fully at the risk of the customer. Copies of this document or other SMSC literature, as well as the Terms of Sale Agreement, may be obtained by visiting SMSC's website at <http://www.smisc.com>. SMSC is a registered trademark of Standard Microsystems Corporation ("SMSC"). Product names and company names are the trademarks of their respective holders.

SMSC DISCLAIMS AND EXCLUDES ANY AND ALL WARRANTIES, INCLUDING WITHOUT LIMITATION ANY AND ALL IMPLIED WARRANTIES OF MERCHANTABILITY, FITNESS FOR A PARTICULAR PURPOSE, TITLE, AND AGAINST INFRINGEMENT AND THE LIKE, AND ANY AND ALL WARRANTIES ARISING FROM ANY COURSE OF DEALING OR USAGE OF TRADE. IN NO EVENT SHALL SMSC BE LIABLE FOR ANY DIRECT, INCIDENTAL, INDIRECT, SPECIAL, PUNITIVE, OR CONSEQUENTIAL DAMAGES; OR FOR LOST DATA, PROFITS, SAVINGS OR REVENUES OF ANY KIND; REGARDLESS OF THE FORM OF ACTION, WHETHER BASED ON CONTRACT; TORT; NEGLIGENCE OF SMSC OR OTHERS; STRICT LIABILITY; BREACH OF WARRANTY; OR OTHERWISE; WHETHER OR NOT ANY REMEDY OF BUYER IS HELD TO HAVE FAILED OF ITS ESSENTIAL PURPOSE, AND WHETHER OR NOT SMSC HAS BEEN ADVISED OF THE POSSIBILITY OF SUCH DAMAGES.

Pin Configuration

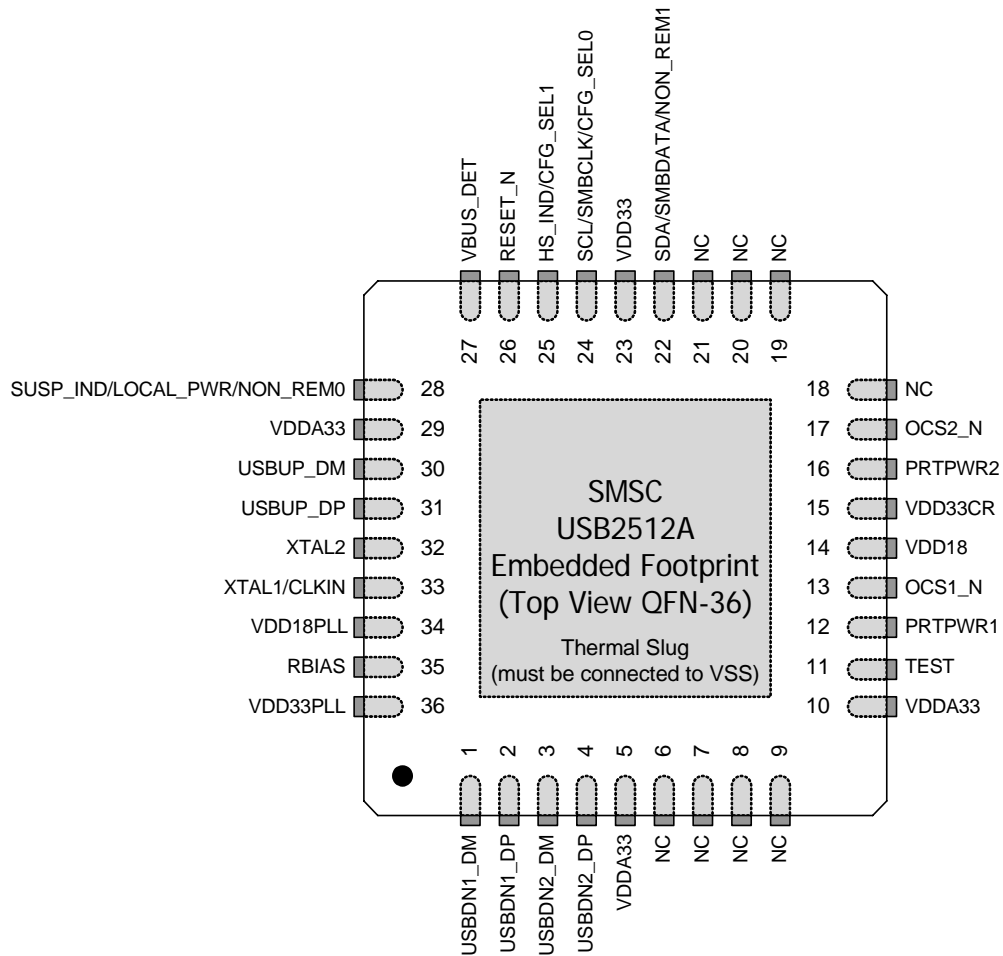

Indicates pins on the bottom of the device.

Figure 1 USB2512A 36-Pin QFN (Embedded Footprint)

Block Diagram

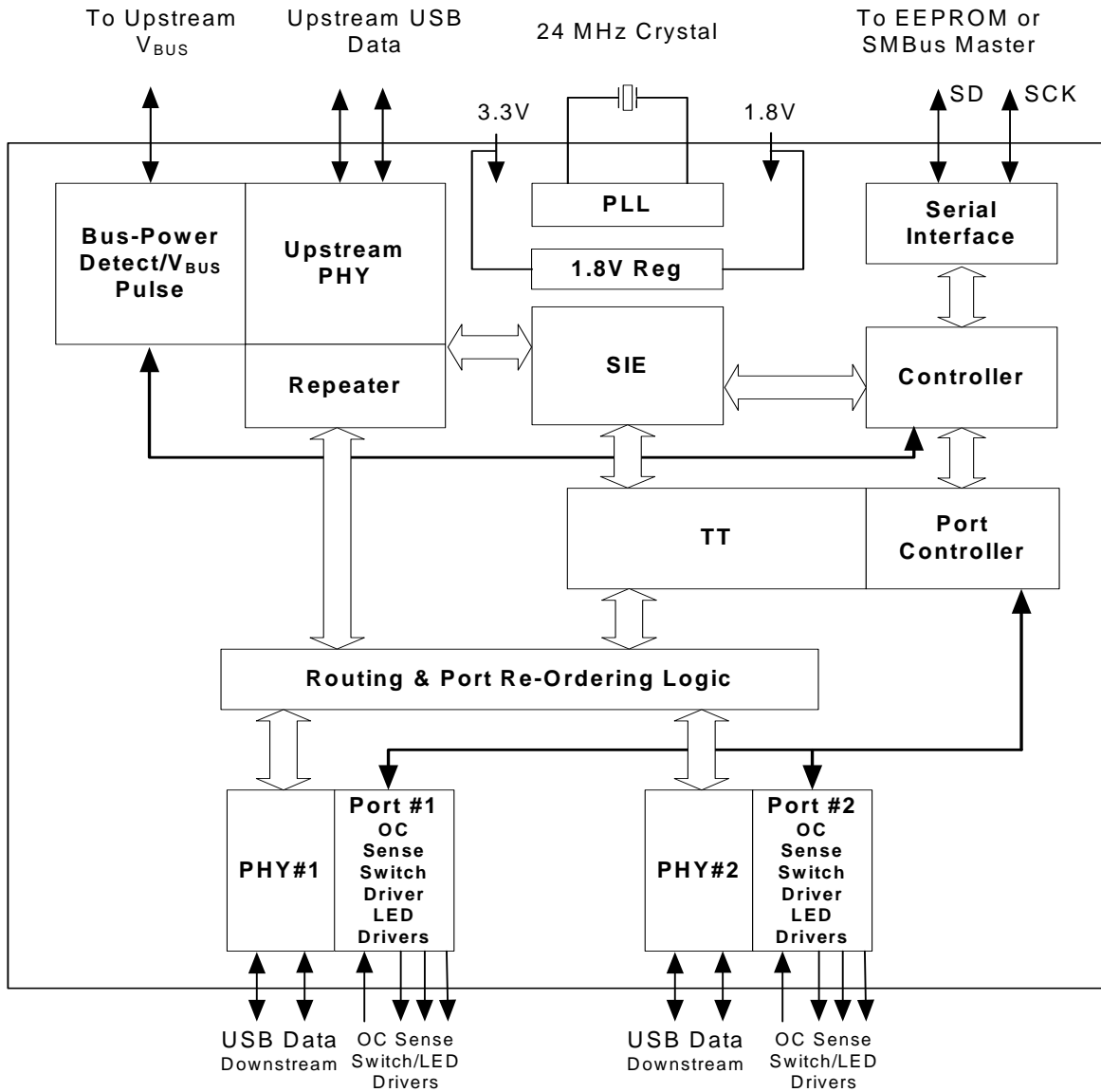
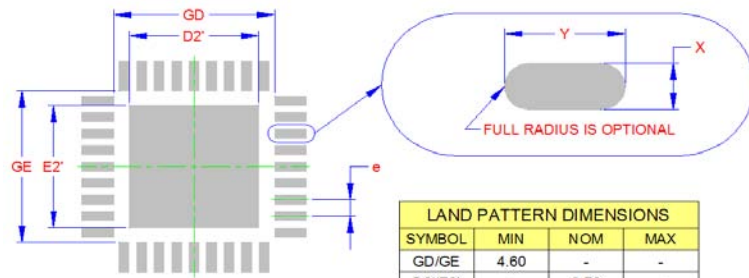
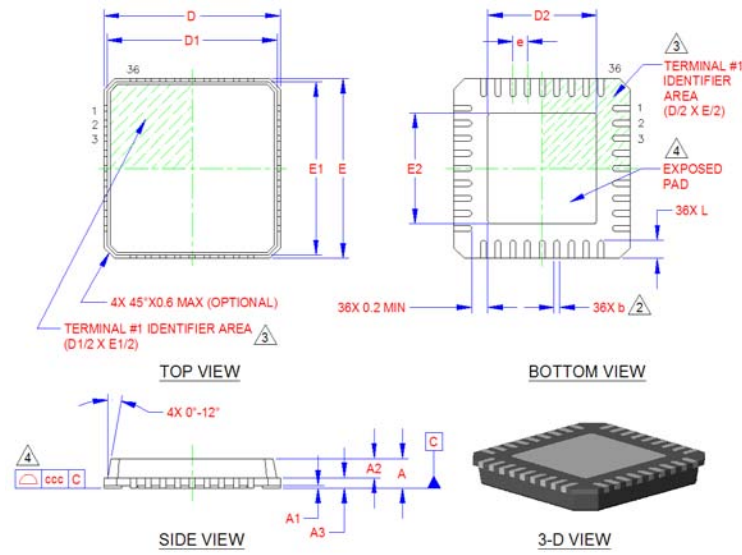

Figure 2 USB2512A Block Diagram

Package Outline



THE USER MAY MODIFY THE PCB LAND PATTERN DIMENSIONS BASED ON THEIR EXPERIENCE AND/OR PROCESS CAPABILITY

LAND PATTERN DIMENSIONS			
SYMBOL	MIN	NOM	MAX
GD/GE	4.60	-	-
D2'/E2'	-	3.70	-
X	-	-	0.28
Y	-	-	0.90
e	-	0.50	-

RECOMMENDED PCB LAND PATTERN

COMMON DIMENSIONS					
SYMBOL	MIN	NOM	MAX	NOTE	REMARK
A	0.80	-	1.00	-	OVERALL PACKAGE HEIGHT
A1	0	0.02	0.05	-	STANDOFF
A2	0.60	-	0.80	-	MOLD CAP THICKNESS
A3	-	0.20 REF	-	-	LEADFRAME THICKNESS
D/E	5.85	6.00	6.15	-	X/Y BODY SIZE
D1/E1	5.55	-	5.95	-	X/Y MOLD CAP SIZE
D2/E2	3.55	3.70	3.85	2	X/Y EXPOSED PAD SIZE
L	0.50	0.60	0.75	-	TERMINAL LENGTH
b	0.18	0.25	0.30	2	TERMINAL WIDTH
e	-	0.50 BSC	-	-	TERMINAL PITCH

- NOTES:**
- ALL DIMENSIONS ARE IN MILLIMETERS.
 - POSITION TOLERANCE OF EACH TERMINAL AND EXPOSED PAD IS $\pm 0.05\text{mm}$ AT MAXIMUM MATERIAL CONDITION. DIMENSIONS "b" APPLIES TO PLATED TERMINALS AND IT IS MEASURED BETWEEN 0.15 AND 0.30 mm FROM THE TERMINAL TIP.
 - DETAILS OF TERMINAL #1 IDENTIFIER ARE OPTIONAL BUT MUST BE LOCATED WITHIN THE AREA INDICATED.
 - COPLANARITY ZONE APPLIES TO EXPOSED PAD AND TERMINALS.

Figure 3 36-Pin QFN, 6x6mm Body, 0.5mm Pitch

Mouser Electronics

Authorized Distributor

Click to View Pricing, Inventory, Delivery & Lifecycle Information:

[Microchip:](#)

[USB2512A-AEZG](#) [USB2512A-AEZG-TR](#)

Компания «Life Electronics» занимается поставками электронных компонентов импортного и отечественного производства от производителей и со складов крупных дистрибьюторов Европы, Америки и Азии.

С конца 2013 года компания активно расширяет линейку поставок компонентов по направлению коаксиальный кабель, кварцевые генераторы и конденсаторы (керамические, пленочные, электролитические), за счёт заключения дистрибьюторских договоров

Мы предлагаем:

- Конкуренспособные цены и скидки постоянным клиентам.
- Специальные условия для постоянных клиентов.
- Подбор аналогов.
- Поставку компонентов в любых объемах, удовлетворяющих вашим потребностям.
- Приемлемые сроки поставки, возможна ускоренная поставка.
- Доставку товара в любую точку России и стран СНГ.
- Комплексную поставку.
- Работу по проектам и поставку образцов.
- Формирование склада под заказчика.
- Сертификаты соответствия на поставляемую продукцию (по желанию клиента).
- Тестирование поставляемой продукции.
- Поставку компонентов, требующих военную и космическую приемку.
- Входной контроль качества.
- Наличие сертификата ISO.

В составе нашей компании организован Конструкторский отдел, призванный помогать разработчикам, и инженерам.

Конструкторский отдел помогает осуществить:

- Регистрацию проекта у производителя компонентов.
- Техническую поддержку проекта.
- Защиту от снятия компонента с производства.
- Оценку стоимости проекта по компонентам.
- Изготовление тестовой платы монтаж и пусконаладочные работы.



Тел: +7 (812) 336 43 04 (многоканальный)
Email: org@lifeelectronics.ru