



**MCP6XXX Amplifier
Evaluation Board 1
User's Guide**

Note the following details of the code protection feature on Microchip devices:

- Microchip products meet the specification contained in their particular Microchip Data Sheet.
- Microchip believes that its family of products is one of the most secure families of its kind on the market today, when used in the intended manner and under normal conditions.
- There are dishonest and possibly illegal methods used to breach the code protection feature. All of these methods, to our knowledge, require using the Microchip products in a manner outside the operating specifications contained in Microchip's Data Sheets. Most likely, the person doing so is engaged in theft of intellectual property.
- Microchip is willing to work with the customer who is concerned about the integrity of their code.
- Neither Microchip nor any other semiconductor manufacturer can guarantee the security of their code. Code protection does not mean that we are guaranteeing the product as "unbreakable."

Code protection is constantly evolving. We at Microchip are committed to continuously improving the code protection features of our products. Attempts to break Microchip's code protection feature may be a violation of the Digital Millennium Copyright Act. If such acts allow unauthorized access to your software or other copyrighted work, you may have a right to sue for relief under that Act.

Information contained in this publication regarding device applications and the like is provided only for your convenience and may be superseded by updates. It is your responsibility to ensure that your application meets with your specifications. MICROCHIP MAKES NO REPRESENTATIONS OR WARRANTIES OF ANY KIND WHETHER EXPRESS OR IMPLIED, WRITTEN OR ORAL, STATUTORY OR OTHERWISE, RELATED TO THE INFORMATION, INCLUDING BUT NOT LIMITED TO ITS CONDITION, QUALITY, PERFORMANCE, MERCHANTABILITY OR FITNESS FOR PURPOSE. Microchip disclaims all liability arising from this information and its use. Use of Microchip devices in life support and/or safety applications is entirely at the buyer's risk, and the buyer agrees to defend, indemnify and hold harmless Microchip from any and all damages, claims, suits, or expenses resulting from such use. No licenses are conveyed, implicitly or otherwise, under any Microchip intellectual property rights.

Trademarks

The Microchip name and logo, the Microchip logo, Accuron, dsPIC, KEELOQ, KEELOQ logo, microID, MPLAB, PIC, PICmicro, PICSTART, PRO MATE, rfPIC and SmartShunt are registered trademarks of Microchip Technology Incorporated in the U.S.A. and other countries.

AmpLab, FilterLab, Linear Active Thermistor, Migratable Memory, MXDEV, MXLAB, SEEVAL, SmartSensor and The Embedded Control Solutions Company are registered trademarks of Microchip Technology Incorporated in the U.S.A.

Analog-for-the-Digital Age, Application Maestro, CodeGuard, dsPICDEM, dsPICDEM.net, dsPICworks, ECAN, ECONOMONITOR, FanSense, FlexROM, fuzzyLAB, In-Circuit Serial Programming, ICSP, ICEPIC, Mindi, MiWi, MPASM, MPLAB Certified logo, MPLIB, MPLINK, PICkit, PICDEM, PICDEM.net, PICLAB, PICtail, PowerCal, PowerInfo, PowerMate, PowerTool, REAL ICE, rFLAB, Select Mode, Smart Serial, SmartTel, Total Endurance, UNI/O, WiperLock and ZENA are trademarks of Microchip Technology Incorporated in the U.S.A. and other countries.

SQTP is a service mark of Microchip Technology Incorporated in the U.S.A.

All other trademarks mentioned herein are property of their respective companies.

© 2007, Microchip Technology Incorporated, Printed in the U.S.A., All Rights Reserved.

 Printed on recycled paper.

QUALITY MANAGEMENT SYSTEM
CERTIFIED BY DNV
== ISO/TS 16949:2002 ==

Microchip received ISO/TS-16949:2002 certification for its worldwide headquarters, design and wafer fabrication facilities in Chandler and Tempe, Arizona; Gresham, Oregon and design centers in California and India. The Company's quality system processes and procedures are for its PIC® MCUs and dsPIC® DSCs, KEELOQ® code hopping devices, Serial EEPROMs, microperipherals, nonvolatile memory and analog products. In addition, Microchip's quality system for the design and manufacture of development systems is ISO 9001:2000 certified.



MCP6XXX AMPLIFIER EVALUATION BOARD 1 USER'S GUIDE

Table of Contents

Preface	1
Introduction.....	1
Document Layout	1
Conventions Used in this Guide	2
Recommended Reading.....	3
The Microchip Web Site	3
Customer Support	3
Document Revision History	3
Chapter 1. Product Overview	5
1.1 Introduction	5
1.2 MCP6XXX Amplifier Evaluation Board 1 Kit Contents	5
1.3 Microchip's Web-Based Mindi™ Analog Simulator	6
1.4 MCP6XXX Amplifier Evaluation Board 1 Description	6
Chapter 2. Installation and Operation	7
2.1 Introduction	7
2.2 Required Tools	7
2.3 MCP6XXX Amplifier Evaluation Board 1 Set-up	7
2.4 MCP6XXX Amplifier Evaluation Board 1 Operation	18
Appendix A. Schematic and Layouts	29
A.1 Introduction	29
A.2 Board - Schematic	30
A.3 Board - Top Silk Layer	31
A.4 Board - Top Metal Layer	32
A.5 Board - Bottom Metal Layer	33
Appendix B. Bill Of Materials (BOM)	35
B.1 MCP6XXX Amplifier Evaluation Board 1 BOM	35
Worldwide Sales and Service	38

MCP6XXX Amplifier Evaluation Board 1 User's Guide

NOTES:



MCP6XXX AMPLIFIER EVALUATION BOARD 1 USER'S GUIDE

Preface

NOTICE TO CUSTOMERS

All documentation becomes dated, and this manual is no exception. Microchip tools and documentation are constantly evolving to meet customer needs, so some actual dialogs and/or tool descriptions may differ from those in this document. Please refer to our web site (www.microchip.com) to obtain the latest documentation available.

Documents are identified with a "DS" number. This number is located on the bottom of each page, in front of the page number. The numbering convention for the DS number is "DSXXXXA", where "XXXX" is the document number and "A" is the revision level of the document.

For the most up-to-date information on development tools, see the MPLAB® IDE on-line help. Select the Help menu, and then Topics to open a list of available on-line help files.

INTRODUCTION

This chapter contains general information that will be useful to know before using the MCP6XXX Amplifier Evaluation Board 1. Items discussed in this chapter include:

- Document Layout
- Conventions Used in this Guide
- Recommended Reading
- The Microchip Web Site
- Customer Support
- Document Revision History

DOCUMENT LAYOUT

This document describes how to use the MCP6XXX Amplifier Evaluation Board 1. The manual layout is as follows:

- **Chapter 1. "Product Overview"** - Provides all important information about the MCP6XXX Amplifier Evaluation Board 1.
- **Chapter 2. "Installation and Operation"** – Covers the installation and operation of the MCP6XXX Amplifier Evaluation Board 1. It lists the required tools, shows how to set up the board, and demonstrates how to verify the operation.
- **Appendix A. "Schematic and Layouts"** – Shows the schematic and board layouts for the MCP6XXX Amplifier Evaluation Board 1.
- **Appendix B. "Bill Of Materials (BOM)"** – Lists the parts used to build the MCP6XXX Amplifier Evaluation Board 1.

MCP6XXX Amplifier Evaluation Board 1 User's Guide

CONVENTIONS USED IN THIS GUIDE

This manual uses the following documentation conventions:

DOCUMENTATION CONVENTIONS

Description	Represents	Examples
Arial font:		
Italic characters	Referenced books	<i>MPLAB[®] IDE User's Guide</i>
	Emphasized text	...is the <i>only</i> compiler...
Initial caps	A window	the Output window
	A dialog	the Settings dialog
	A menu selection	select Enable Programmer
Quotes	A field name in a window or dialog	"Save project before build"
Underlined, italic text with right angle bracket	A menu path	<u><i>File>Save</i></u>
Bold characters	A dialog button	Click OK
	A tab	Click the Power tab
N'Rnnnn	A number in verilog format, where N is the total number of digits, R is the radix and n is a digit.	4'b0010, 2'hF1
Text in angle brackets < >	A key on the keyboard	Press <Enter>, <F1>
Courier New font:		
Plain Courier New	Sample source code	#define START
	Filenames	autoexec.bat
	File paths	c:\mcc18\h
	Keywords	_asm, _endasm, static
	Command-line options	-Opa+, -Opa-
	Bit values	0, 1
	Constants	0xFF, 'A'
Italic Courier New	A variable argument	<i>file.o</i> , where <i>file</i> can be any valid filename
Square brackets []	Optional arguments	mcc18 [options] <i>file</i> [options]
Curly brackets and pipe character: { }	Choice of mutually exclusive arguments; an OR selection	errorlevel {0 1}
Ellipses...	Replaces repeated text	var_name [, var_name...]
	Represents code supplied by user	void main (void) { ... }

RECOMMENDED READING

This user's guide describes how to use MCP6XXX Amplifier Evaluation Board 1. Other useful documents are listed below. The following Microchip documents are available and recommended as supplemental reference resources.

MCP6021 Data Sheet “Rail-to-Rail Input/Output, 10 MHz Op Amps“ (DS21685)

This data sheet provides detailed information regarding the MCP6021 product family.

THE MICROCHIP WEB SITE

Microchip provides online support via our web site at www.microchip.com. This web site is used as a means to make files and information easily available to customers. Accessible by using your favorite Internet browser, the web site contains the following information:

- **Product Support** – Data sheets and errata, application notes and sample programs, design resources, user's guides and hardware support documents, latest software releases and archived software
- **General Technical Support** – Frequently Asked Questions (FAQs), technical support requests, online discussion groups, Microchip consultant program member listing
- **Business of Microchip** – Product selector and ordering guides, latest Microchip press releases, listing of seminars and events, listings of Microchip sales offices, distributors and factory representatives

CUSTOMER SUPPORT

Users of Microchip products can receive assistance through several channels:

- Distributor or Representative
- Local Sales Office
- Field Application Engineer (FAE)
- Technical Support
- Development Systems Information Line

Customers should contact their distributor, representative or field application engineer for support. Local sales offices are also available to help customers. A listing of sales offices and locations is included in the back of this document.

Technical support is available through the web site at: <http://support.microchip.com>.

DOCUMENT REVISION HISTORY

Revision A (July 2007)

- Initial Release of this Document.

MCP6XXX Amplifier Evaluation Board 1 User's Guide

NOTES:

Chapter 1. Product Overview

1.1 INTRODUCTION

The MCP6XXX Amplifier Evaluation Board 1 is described by the following:

- Assembly # : 114-00147
- Order # : MCP6XXXEV-AMP1
- Name: MCP6XXX Amplifier Evaluation Board 1

Items discussed in this chapter include:

- **Section 1.2 “MCP6XXX Amplifier Evaluation Board 1 Kit Contents”**
- **Section 1.3 “Microchip’s Web-Based Mindi™ Analog Simulator”**
- **Section 1.4 “MCP6XXX Amplifier Evaluation Board 1 Description”**

1.2 MCP6XXX AMPLIFIER EVALUATION BOARD 1 KIT CONTENTS

- MCP6XXX Amplifier Evaluation Board 1 - One partially assembled board
- Important Information “Read First”
- Accessory Bag - Contains loose parts for populating sockets on board
- Analog and Interface Products Demonstration Boards CD-ROM (DS21912)
 - MCP6XXX Amplifier Evaluation Board 1 User’s Guide (DS51667)



FIGURE 1-1: MCP6XXX Amplifier Evaluation Board 1 Kit.

MCP6XXX Amplifier Evaluation Board 1 User's Guide

1.3 MICROCHIP'S WEB-BASED MINDI™ ANALOG SIMULATOR

The Mindi™ Analog Simulator tool is an innovative software tool that simplifies analog circuit design. The Mindi™ Analog Simulator tool supports the following application circuits: 1) Active Filters, 2) Amplifiers, 3) Battery Chargers, and 4) DC-to-DC Converters. The Mindi™ Amplifier Designer provides full schematic diagrams of the amplifier application circuit with recommended component values and displays the responses in frequency and time domains.

The Mindi™ Analog Simulator tool is a free web-based design tool available on the Microchip web site at <http://www.microchip.com> under “**Online Simulation Tools**” or by going directly to the Mindi™ web site at <http://www.microchip.com/mindi>.

The circuit simulator within the Mindi™ Analog Simulator tool can be downloaded and installed on a personal computer (PC) for more convenient simulations. Modified circuit files can also be downloaded to the PC.

1.4 MCP6XXX AMPLIFIER EVALUATION BOARD 1 DESCRIPTION

The MCP6XXX Amplifier Evaluation Board 1 is designed to support inverting/non-inverting amplifiers, voltage follower, inverting/non-inverting comparators, inverting/non-inverting differentiators.

However, at this time, the Mindi™ Amplifier Designer does not support the non-inverting comparator or the non-inverting differentiator.

MCP6XXX Amplifier Evaluation Board 1 has the following features:

- All amplifier resistors and capacitors are socketed
- All of the component labels on board keep consistent with those on schematic generated in the Mindi™ Amplifier Designer
- Supports all Microchip single op amps
 - PDIP-8 package (e.g., MCP6021) are socketed
 - SOIC-8 package can be accommodated; see **Section 2.4.3 “Amplifier Modification: Using 8-Pin SOIC Op Amps”**
- Test points for connecting lab equipment
- Single supply configuration

Figure 1-2 shows the block diagram of the MCP6XXX Amplifier Evaluation Board 1. Lab equipment can be attached (via test points) to measure the amplifier response.

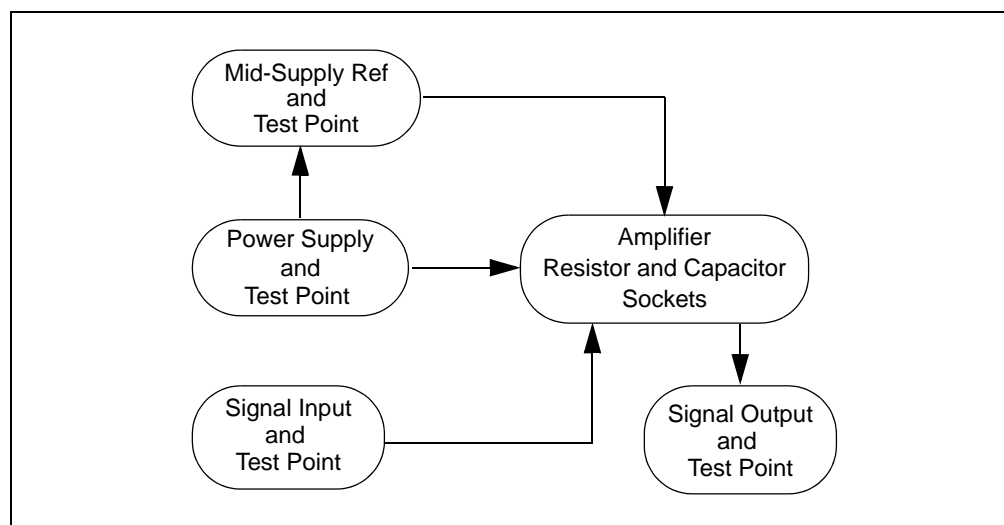

FIGURE 1-2: MCP6XXX Amplifier Evaluation Board 1 Block Diagram.

Chapter 2. Installation and Operation

2.1 INTRODUCTION

This chapter shows how to set up the MCP6XXX Amplifier Evaluation Board 1 and verify its operation. This chapter includes the following topics:

- Required Tools
- MCP6XXX Amplifier Evaluation Board 1 Set-Up
- MCP6XXX Amplifier Evaluation Board 1 Operation

2.2 REQUIRED TOOLS

- Lab power supply
- Lab signal source (e.g., function generator)
- Lab measurement equipment (e.g., oscilloscope)

2.3 MCP6XXX AMPLIFIER EVALUATION BOARD 1 SET-UP

The MCP6XXX Amplifier Evaluation Board 1 is designed to support inverting/non-inverting amplifiers, voltage follower, inverting/non-inverting comparators, inverting/non-inverting differentiators

At this time, the Mindi™ Amplifier Designer does not support the non-inverting comparator or the non-inverting differentiator.

This section details the conversion of these topologies to the MCP6XXX Amplifier Evaluation Board 1. Figure 2-1 shows the circuit diagram for the board.

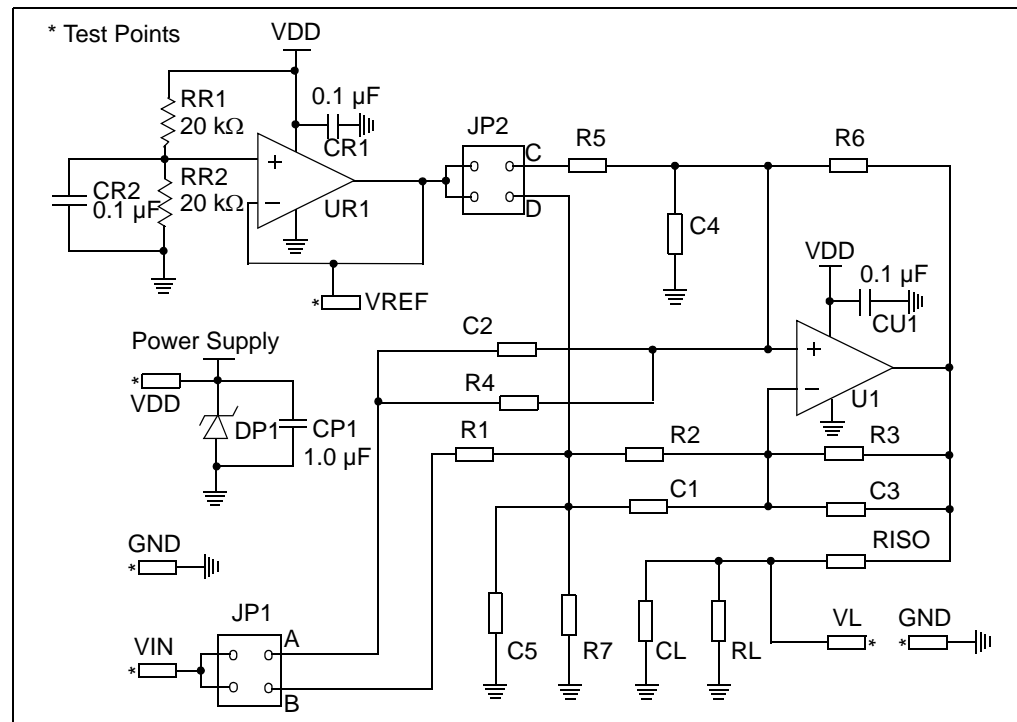

FIGURE 2-1: MCP6XXX Amplifier Evaluation Board 1 Circuit Diagram.

MCP6XXX Amplifier Evaluation Board 1 User's Guide

The power supply voltage should be in the allowed range for the installed op amps. Any of Microchip's op amps that operate below 5.5V can be used. Moreover, power supply is protected by a zener diode with nominal voltage 6.2V and bypassed by a 1.0 μ F capacitor. (See **Figure 2-3: "Power Supply Block."**)

The mid-supply reference consists of a voltage divider and a buffer amplifier. (See **Figure 2-4: "Mid-Supply Reference Block."**)

The resistors and capacitors that are part of an amplifier are placed in pin sockets which are labeled. All of the component labels on board keep consistent with those on schematic generated in the Mindi™ Amplifier Designer. The op amps are bypassed by 0.1 μ F capacitors and the single op amp U1 can have either a PDIP-8 or SOIC-8 package.

- PDIP-8 packages are inserted into the DIP-8 socket to the right of the U1 label
- SOIC-8 packages can be accommodated; see **Section 2.4.3 "Amplifier Modification: Using 8-Pin SOIC Op Amps"**

The (surface mount) test points for power supply, ground, input signal and output signal allow lab equipment to be connected to the board. The MCP6XXX Amplifier Evaluation Board 1 top view is shown in Figure 2-2.

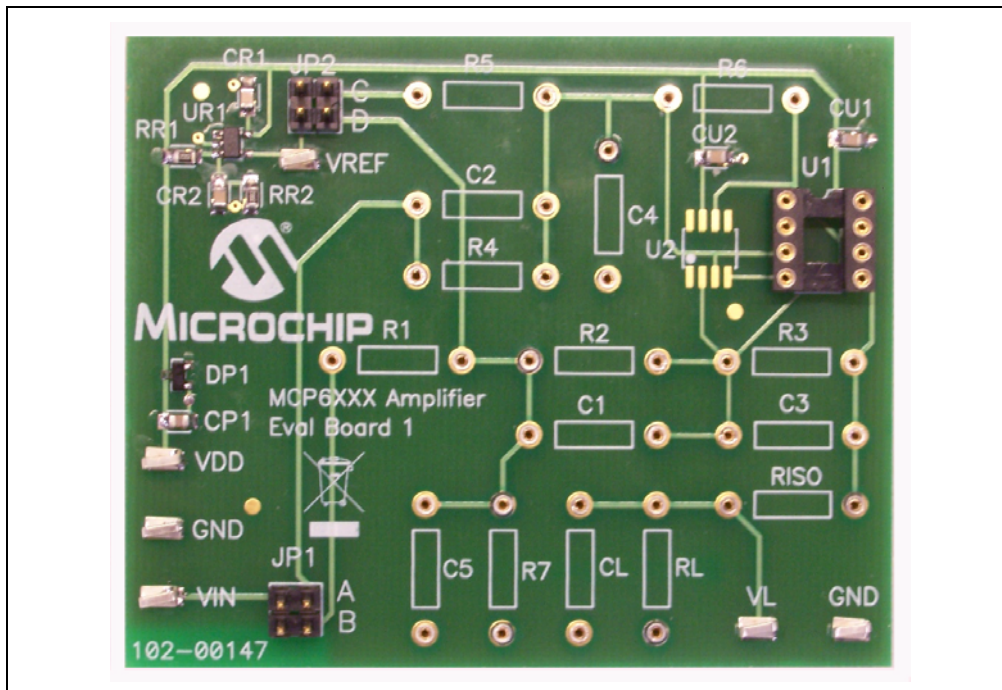

FIGURE 2-2: MCP6XXX Amplifier Evaluation Board 1 Top View.

2.3.1 Top Level Amplifier Circuit Diagrams

2.3.1.1 POWER SUPPLY BLOCK

The power supply is protected by a zener diode and bypassed by a capacitor. Figure 2-3 shows the circuit diagram for the power supply. $C_{P1} = 1.0 \mu\text{F}$.

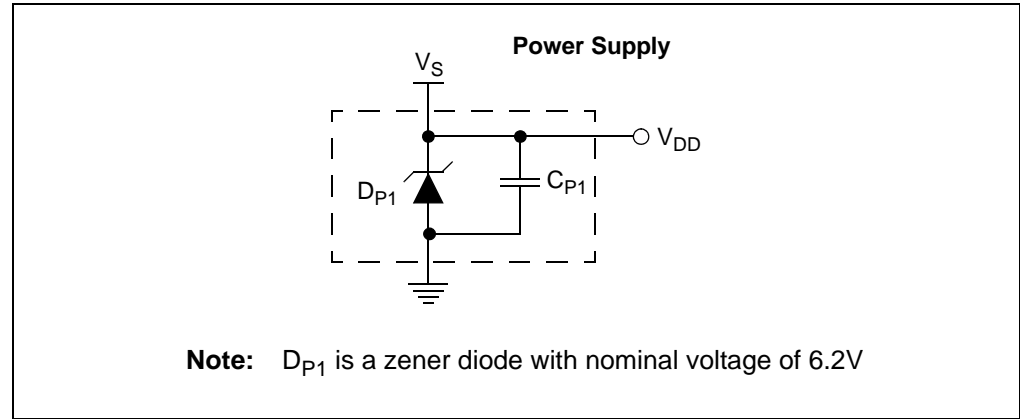
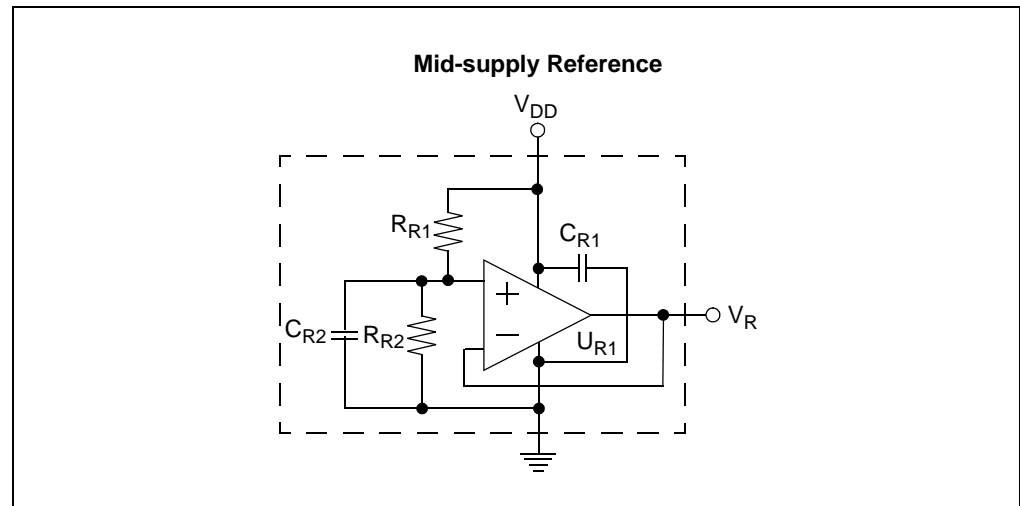

FIGURE 2-3: Power Supply Block.

2.3.1.2 MID-SUPPLY REFERENCE BLOCK

The mid-supply reference consists of a voltage divider and a buffer amplifier. Figure 2-4 shows the circuit diagram for the mid-supply reference. $C_{R1} = C_{R2} = 0.1 \mu\text{F}$, $R_{R1} = R_{R2} = 20.0 \text{ k}\Omega$.



MCP6XXX Amplifier Evaluation Board 1 User's Guide

2.3.1.3 OUTPUT LOAD BLOCK

The output load consists of a capacitor and two resistors. Figure 2-5 shows the circuit diagram for the output load. R_{ISO} is used to stabilize the amplifier when it drives a large capacitive load. R_{ISO} is a short circuit (0Ω) when C_L is small.

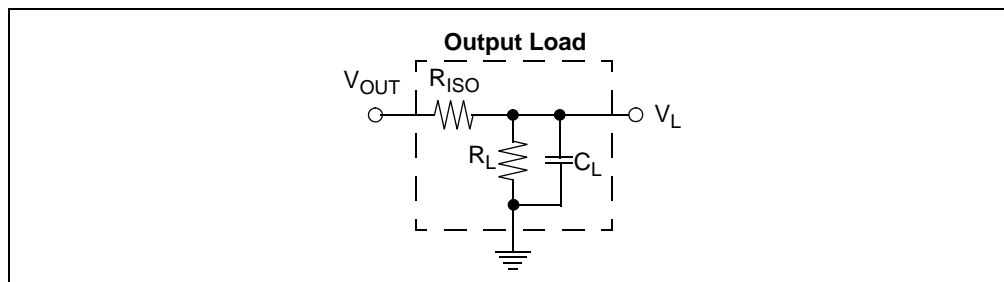

FIGURE 2-5: Output Load Block.

Installation and Operation

2.3.1.4 INVERTING AMPLIFIER

- Amplifies a voltage with an inverting gain. Input and output voltages are shifted by a reference voltage for single supply.
- The Mindi™ Amplifier Designer gives design recommendations for an inverting amplifier circuit; see the circuit diagram shown in Figure 2-6
 - Fill the sockets with the recommended resistors and capacitors
 - Set JP1 and JP2 in the correct positions
(for the given example, JP1: Position B, JP2: Position C)

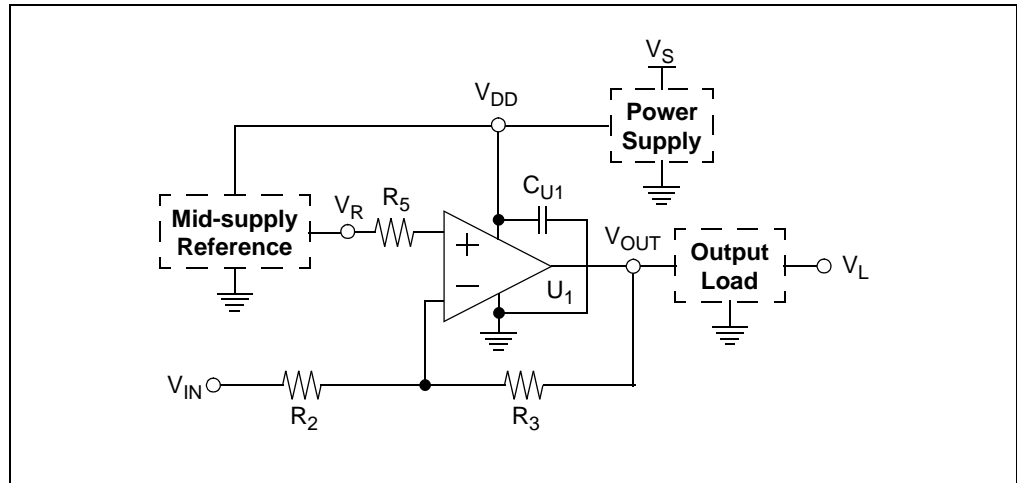

FIGURE 2-6: Inverting Amplifier Circuit Diagram.

Figure 2-7 shows an example of the inverting amplifier circuit diagram supported by MCP6XXX Amplifier Evaluation Board 1.

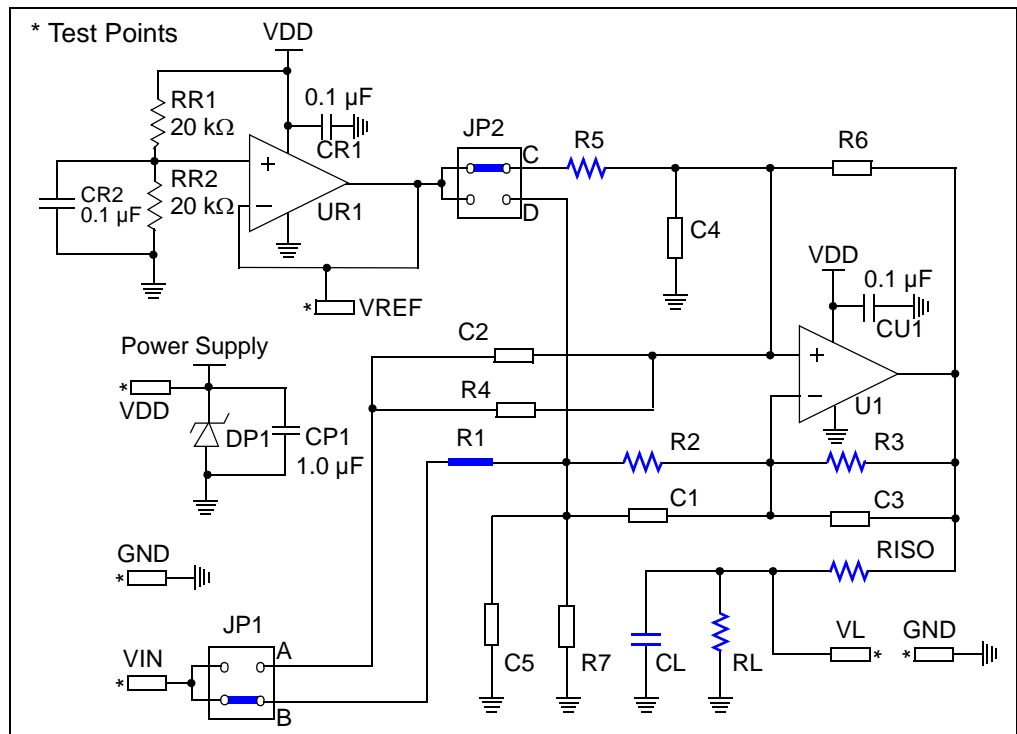

FIGURE 2-7: Inverting Amplifier Example Supported by the MCP6XXX Amplifier Evaluation Board 1.

MCP6XXX Amplifier Evaluation Board 1 User's Guide

2.3.1.5 NON-INVERTING AMPLIFIER

- Amplifies a voltage with a non-inverting gain $> +1$ V/V. Input and output voltages are shifted by a reference voltage for single supply
- The Mindi™ Amplifier Designer gives design recommendations for the non-inverting amplifier circuit; see the circuit diagram shown in Figure 2-8
 - Fill the sockets with the recommended resistors and capacitors
 - Set JP1 and JP2 in the correct positions (for the given example, JP1: Position A, JP2: Position D)

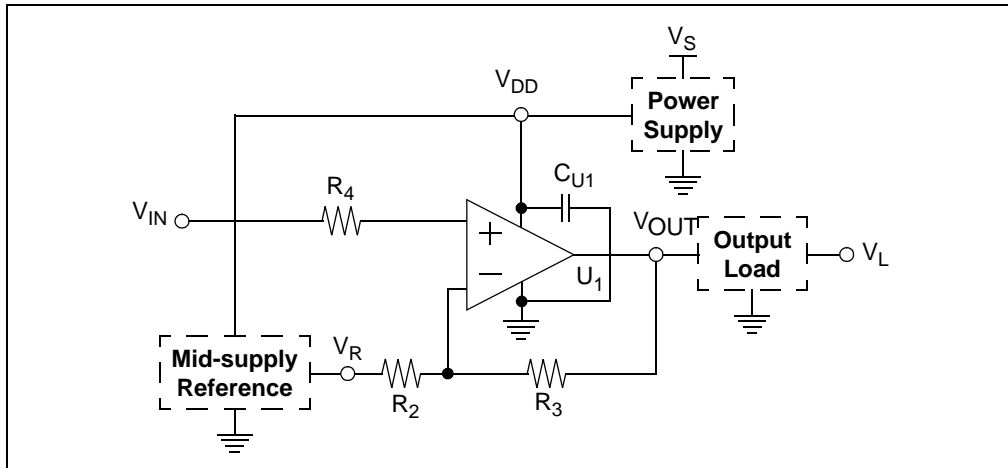

FIGURE 2-8: Non-Inverting Amplifier Circuit Diagram.

Figure 2-9 shows an example of the inverting amplifier circuit diagram supported by MCP6XXX Amplifier Evaluation Board 1.

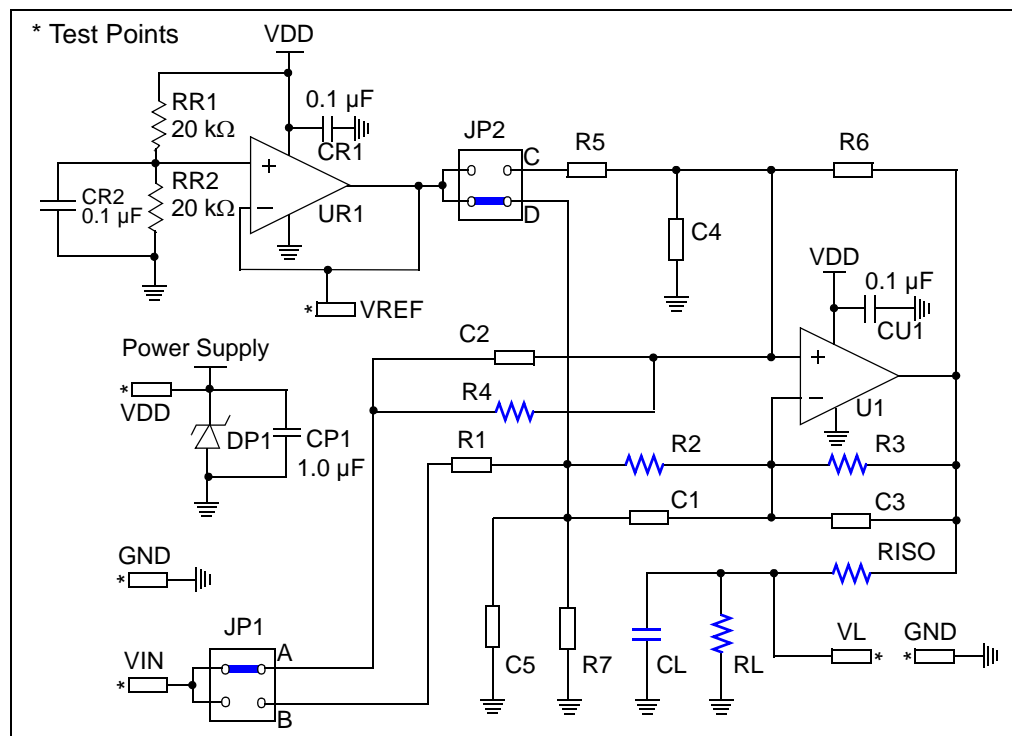

FIGURE 2-9: Non-Inverting Amplifier Example Supported by the MCP6XXX Amplifier Evaluation Board 1.

Installation and Operation

2.3.1.6 VOLTAGE FOLLOWER

- Known as a Unity Gain Buffer and as a Voltage Follower. Amplifies a voltage with a gain of 1 V/V
- The Mindi™ Amplifier Designer gives design recommendations for the voltage follower circuit; see the circuit diagram shown in Figure 2-10
 - Fill the sockets with the recommended resistors and capacitors
 - Set JP1 and JP2 in the correct positions
(for the given example, JP1: Position A, JP2: Position N/A)

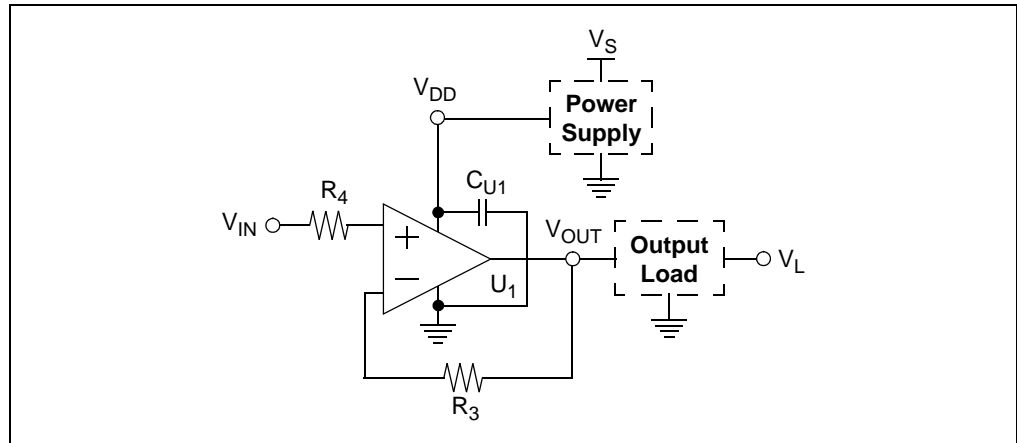

FIGURE 2-10: Voltage Follower Circuit Diagram.

Figure 2-11 shows an example of the voltage amplifier circuit diagram supported by MCP6XXX Amplifier Evaluation Board 1.

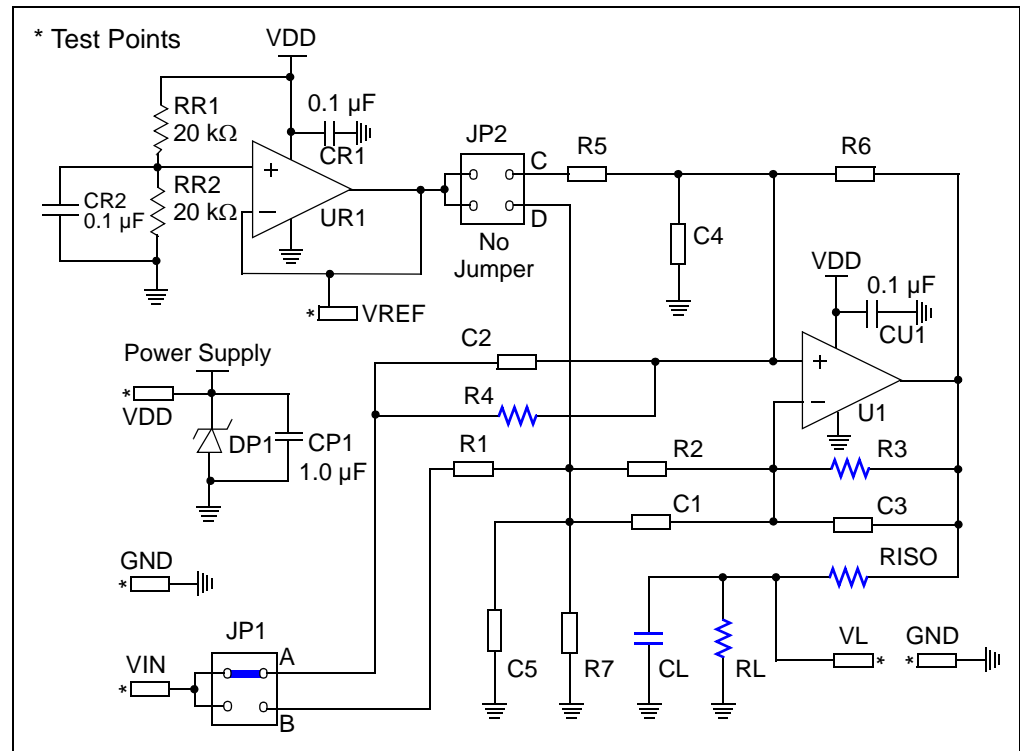

FIGURE 2-11: Voltage Amplifier Example Supported by the MCP6XXX Amplifier Evaluation Board 1.

MCP6XXX Amplifier Evaluation Board 1 User's Guide

2.3.1.7 INVERTING COMPARATOR

- Compares the input voltage to another (reference) voltage and forces the output to one of two digital states. Input signal is applied to the inverting input. The comparison includes a user selected amount of hysteresis. Input and output voltages are shifted by a reference for single supply
- The Mindi™ Amplifier Designer gives design recommendations for the inverting comparator circuit; see the circuit diagram shown in Figure 2-12
 - Fill the sockets with the recommended resistors and capacitors
 - Set JP1 and JP2 in the correct positions (for the given example, JP1: Position B, JP2: Position C)

Note: The MCP6XXX Amplifier Evaluation Board 1 currently only supports the inverting comparator with center trip point = 2.5V.

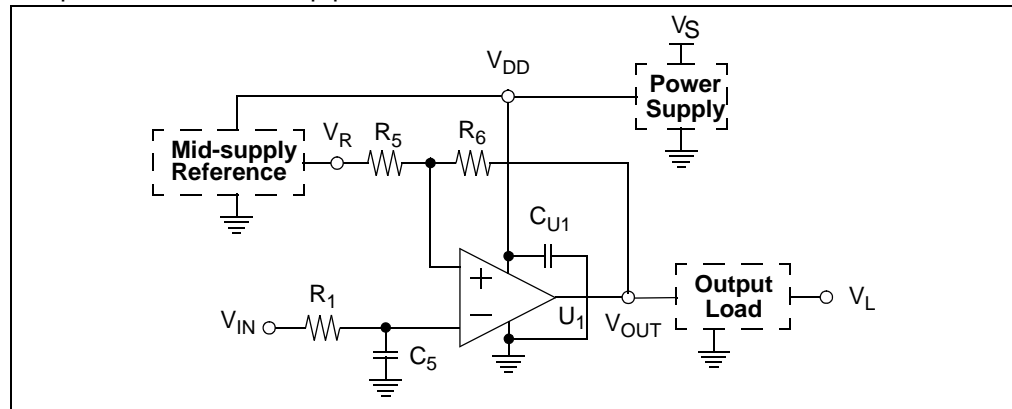

FIGURE 2-12: Inverting Comparator Circuit Diagram.

Figure 2-13 shows an example of the inverting comparator circuit diagram supported by MCP6XXX Amplifier Evaluation Board 1.

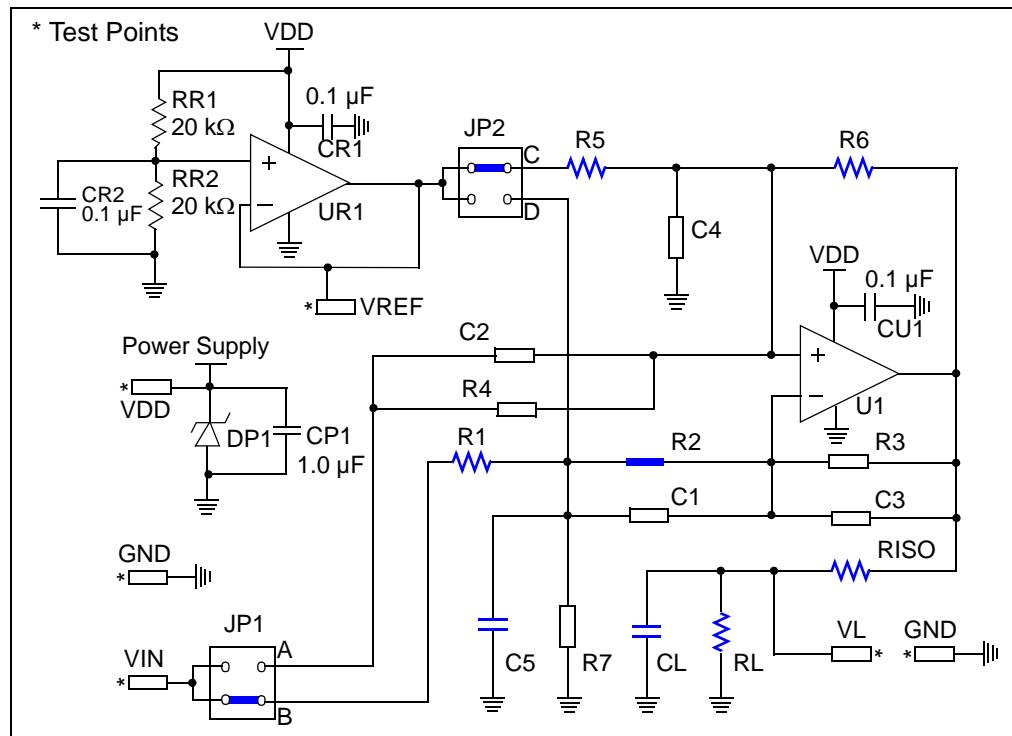

FIGURE 2-13: Inverting Comparator Example Supported by the MCP6XXX Amplifier Evaluation Board 1.

Installation and Operation

2.3.1.8 NON-INVERTING COMPARATOR (NOT CURRENTLY SUPPORTED)

- Compares the input voltage to another (reference) voltage and forces the output to one of two digital states. Input signal is applied to the non-inverting input. The comparison includes a user selected amount of hysteresis. Input and output voltages are shifted by a reference for single supply
- The Mindi™ Amplifier Designer gives design recommendations for the non-inverting comparator circuit; see the circuit diagram shown in Figure 2-14
 - Fill the sockets with the recommended resistors and capacitors
 - Set JP1 and JP2 in the correct positions
(for the given example, JP1: Position A, JP2: Position D)

Note: The MCP6XXX Amplifier Evaluation Board 1 currently only supports the non-inverting comparator with center trip point = 2.5V.

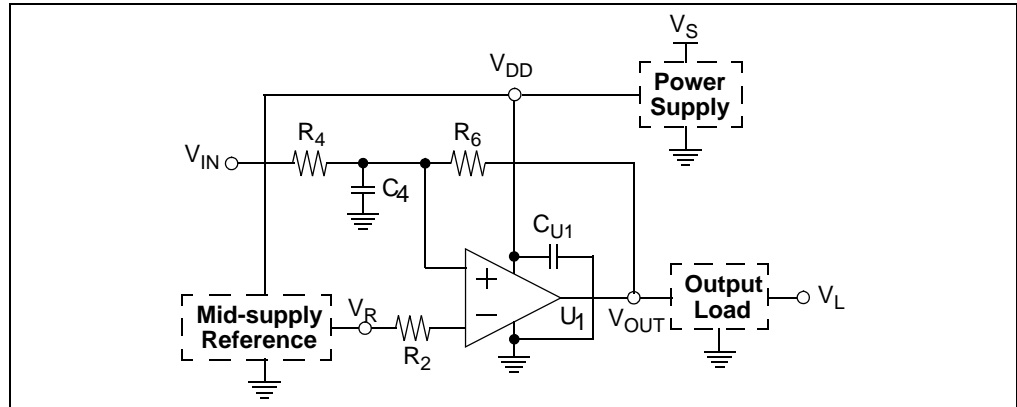

FIGURE 2-14: Non-Inverting Comparator Circuit Diagram.

Figure 2-15 shows an example of the non-inverting comparator circuit diagram supported by the MCP6XXX Amplifier Evaluation Board 1.

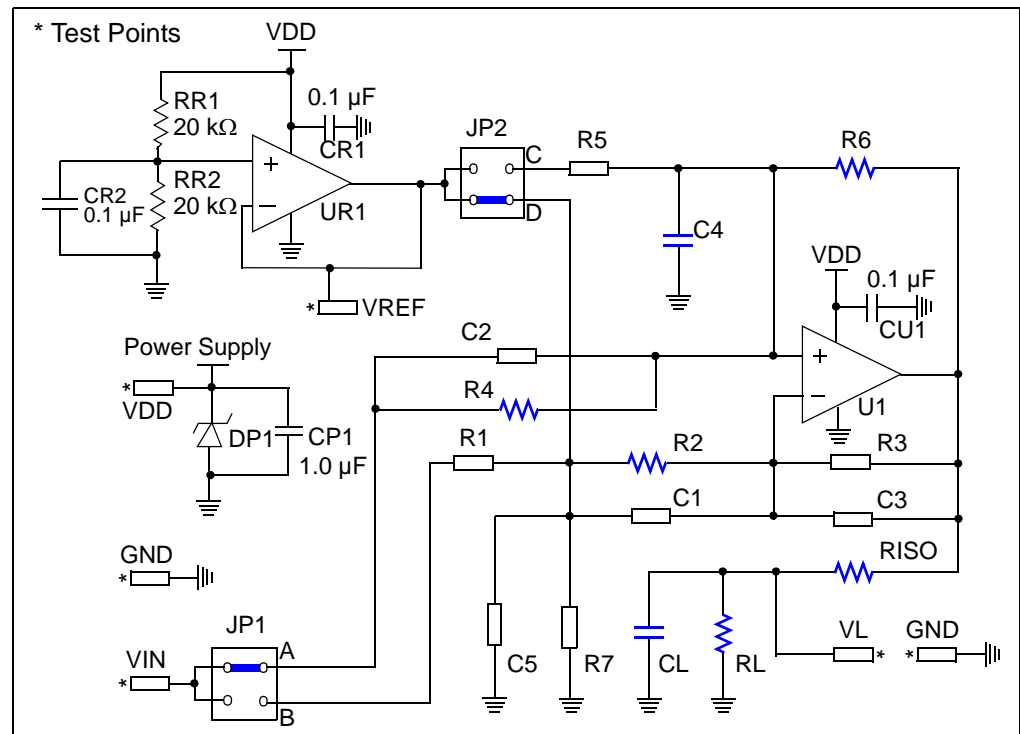

FIGURE 2-15: Non-Inverting Comparator Example Supported by the MCP6XXX Amplifier Evaluation Board 1.

MCP6XXX Amplifier Evaluation Board 1 User's Guide

2.3.1.9 INVERTING DIFFERENTIATOR (NOT CURRENTLY SUPPORTED)

- Differentiates and inverts a voltage with a differentiating frequency. Additional components (R_1 , C_3) achieve stabilization and noise. Input and output voltages are shifted by a reference for single supply
- The Mindi™ Amplifier Designer gives design recommendations for the inverting differentiator circuit; see the circuit diagram shown in Figure 2-16
 - Fill the sockets with the recommended resistors and capacitors
 - Set JP1 and JP2 in the correct positions
(for the given example, JP1: Position B, JP2: Position C)

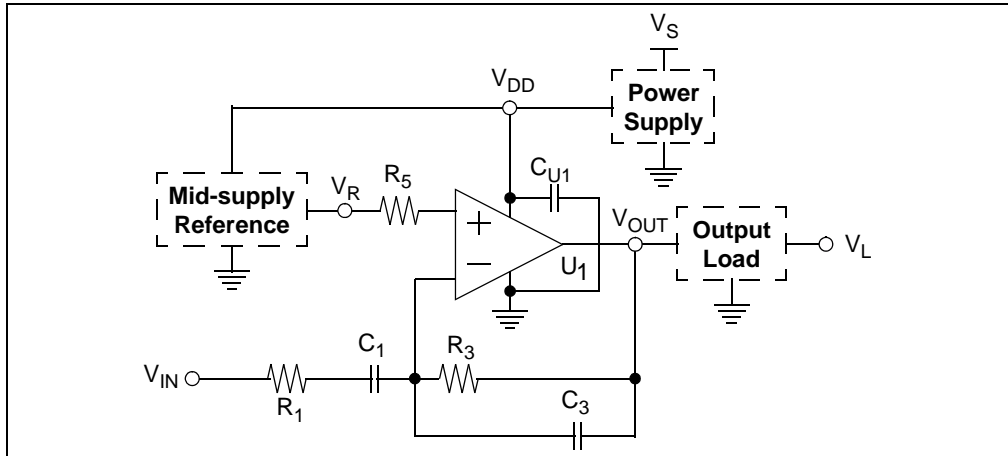

FIGURE 2-16: Inverting Differentiator Circuit Diagram.

Figure 2-17 shows an example of the inverting differentiator circuit diagram supported by MCP6XXX Amplifier Evaluation Board 1.

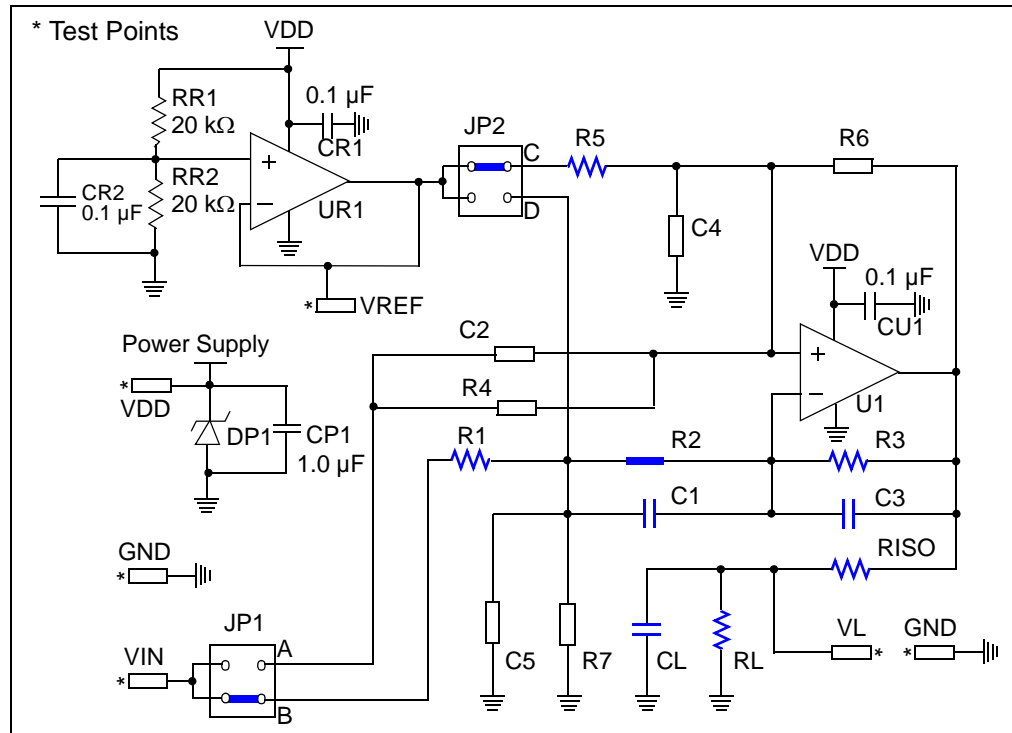

FIGURE 2-17: Inverting Differentiator Example Supported by the MCP6XXX Amplifier Evaluation Board 1.

Installation and Operation

2.3.1.10 NON-INVERTING DIFFERENTIATOR (NOT CURRENTLY SUPPORTED)

- Differentiates and inverts a voltage with a differentiating frequency. Additional components (R_7 , C_3) achieve stabilization and noise. Input and output voltages are shifted by a reference for single supply
- The Mindi™ Amplifier Designer gives design recommendations for the non-inverting differentiator circuit; see the circuit diagram shown in Figure 2-18
 - Fill the sockets with the recommended resistors and capacitors
 - Set JP1 and JP2 in the correct positions
(for the given example, JP1: Position A, JP2: Position C)

Note: The MCP6XXX Amplifier Evaluation Board 1 currently only supports the non-inverting differentiator with center trip point = 2.5V.

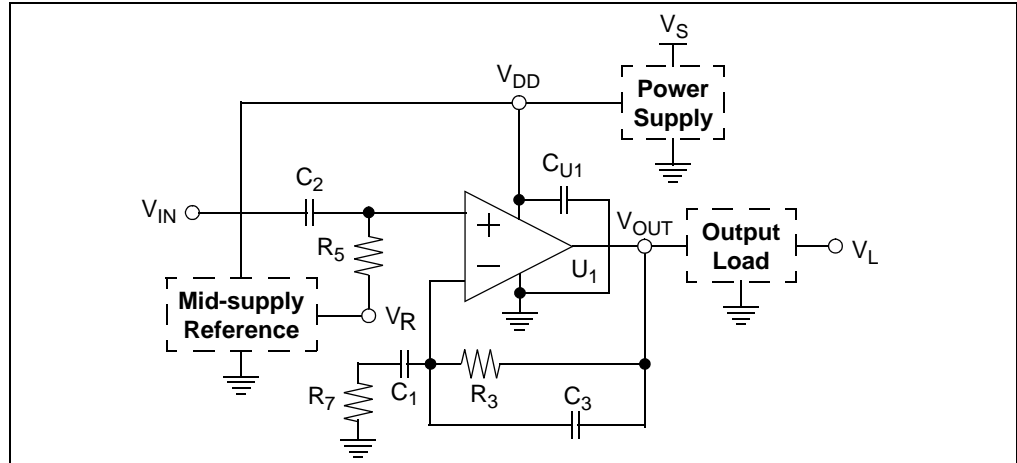

FIGURE 2-18: Non-Inverting Differentiator Circuit Diagram.

Figure 2-19 shows an example of the non-inverting differentiator circuit diagram supported by MCP6XXX Amplifier Evaluation Board 1.

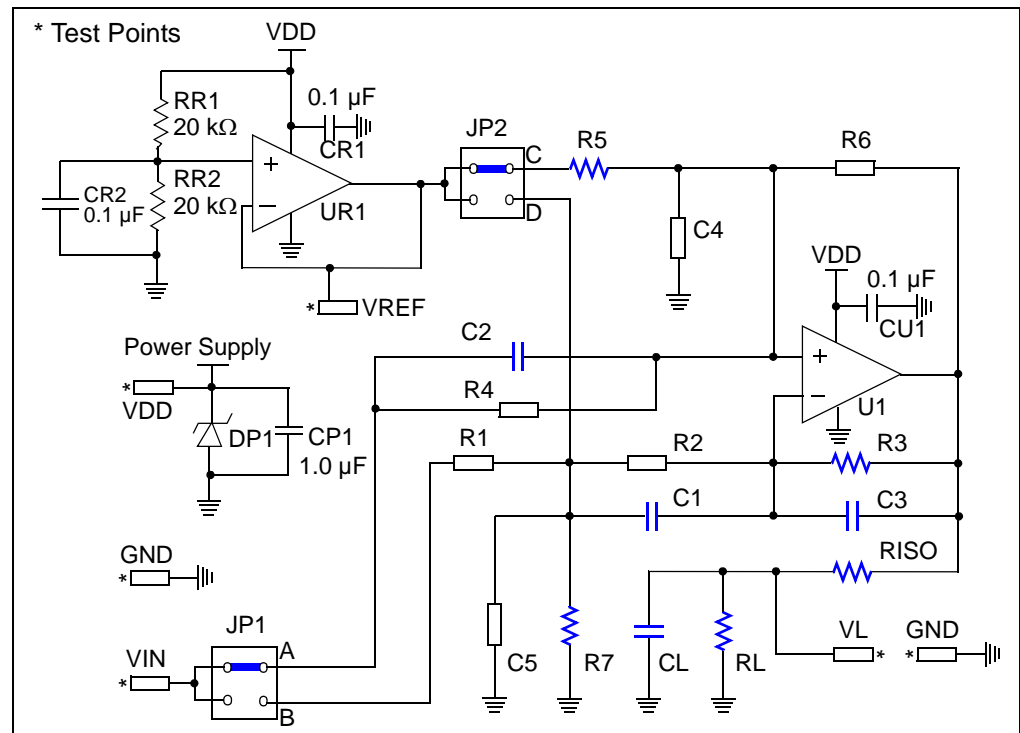

FIGURE 2-19: Non-Inverting Differentiator Example Supported by the MCP6XXX Amplifier Evaluation Board 1.

MCP6XXX Amplifier Evaluation Board 1 User's Guide

2.4 MCP6XXX AMPLIFIER EVALUATION BOARD 1 OPERATION

Items discussed in this section include:

- Building the Amplifier
- Testing the Amplifier
- Amplifier Modification: Using 8-Pin SOIC Op Amps

2.4.1 Building the Amplifier

The accessory bag that comes with this kit makes it quick and easy to evaluate the amplifier described below; it was designed in Mindi™ Amplifier Designer.

This amplifier is described as follows:

- Non-Inverting Amplifier (Single Supply Configuration)
- Power Supply Voltage is 5.0V
- Desired Closed Loop Gain is 2 V/V
- Load Capacitance is 56 pF

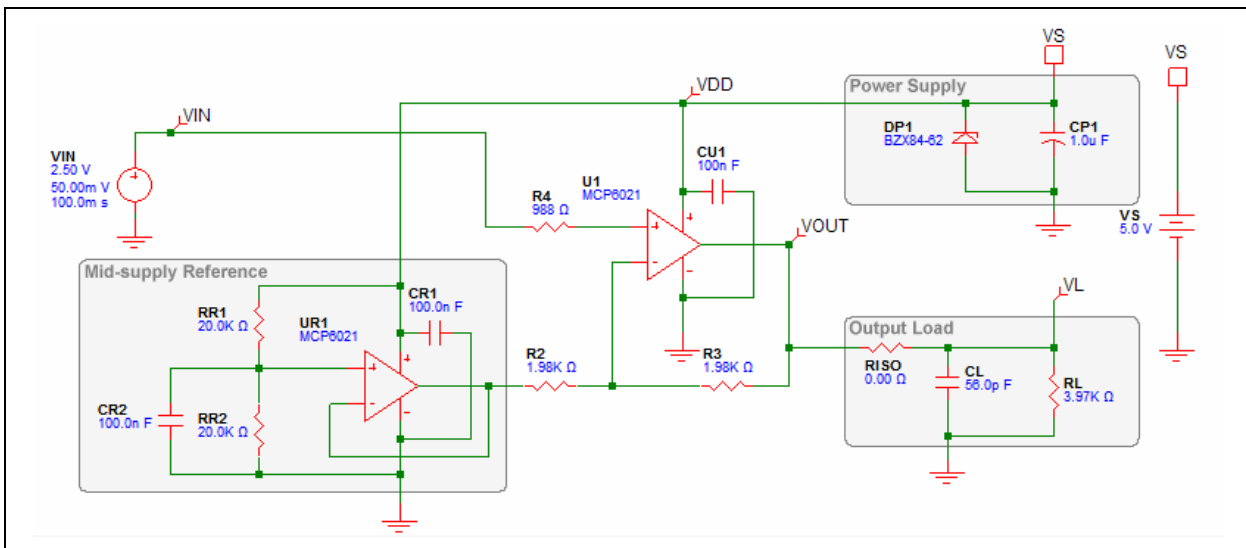

FIGURE 2-20: Non-Inverting Amplifier Designed In Mindi™ Amplifier Designer.

Installation and Operation

Figure 2-21 shows the same circuit redrawn to emphasize the non-inverting amplifier.

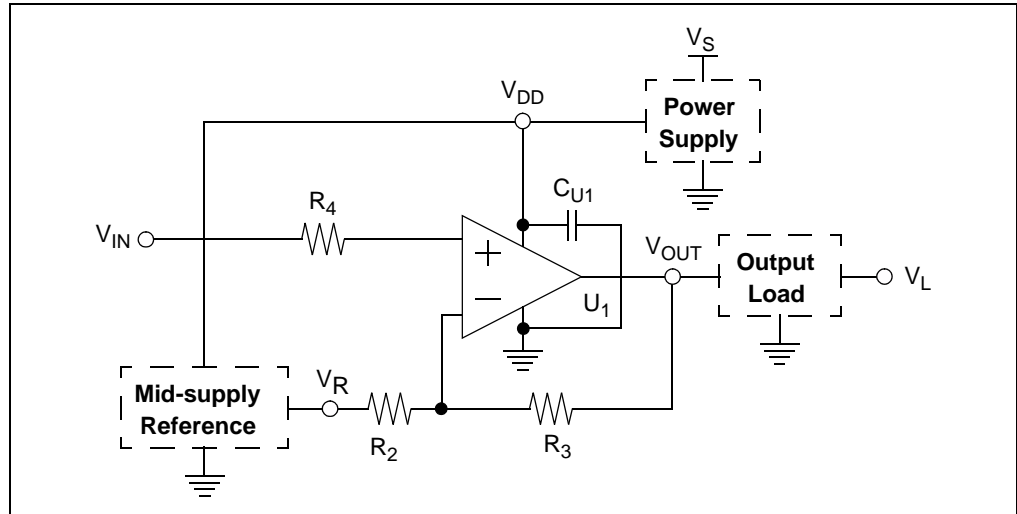

FIGURE 2-21: Non-Inverting Amplifier Circuit Diagram Supported by the MCP6XXX Amplifier Evaluation Board 1 Kit.

Each of the components in Figure 2-21 that needs to be inserted in a socket on the MCP6XXX Amplifier Evaluation Board 1 is listed in Table 2-1 and Table 2-2.

TABLE 2-1: AMPLIFIER COMPONENTS LIST

PCB Labels	Component Values
R2	1.98 k Ω
R3	1.98 k Ω
R4	988 Ω
RISO	0 Ω
RL	3.97 k Ω
CL	56 pF
U1	MCP6021, PDIP-8, 10 MHz

TABLE 2-2: JUMPER POSITIONS

Jumper	Position
JP1	A
JP2	D

MCP6XXX Amplifier Evaluation Board 1 User's Guide

Figure 2-22 shows the fully assembled MCP6XXX Amplifier Evaluation Board 1 for the non-inverting amplifier.

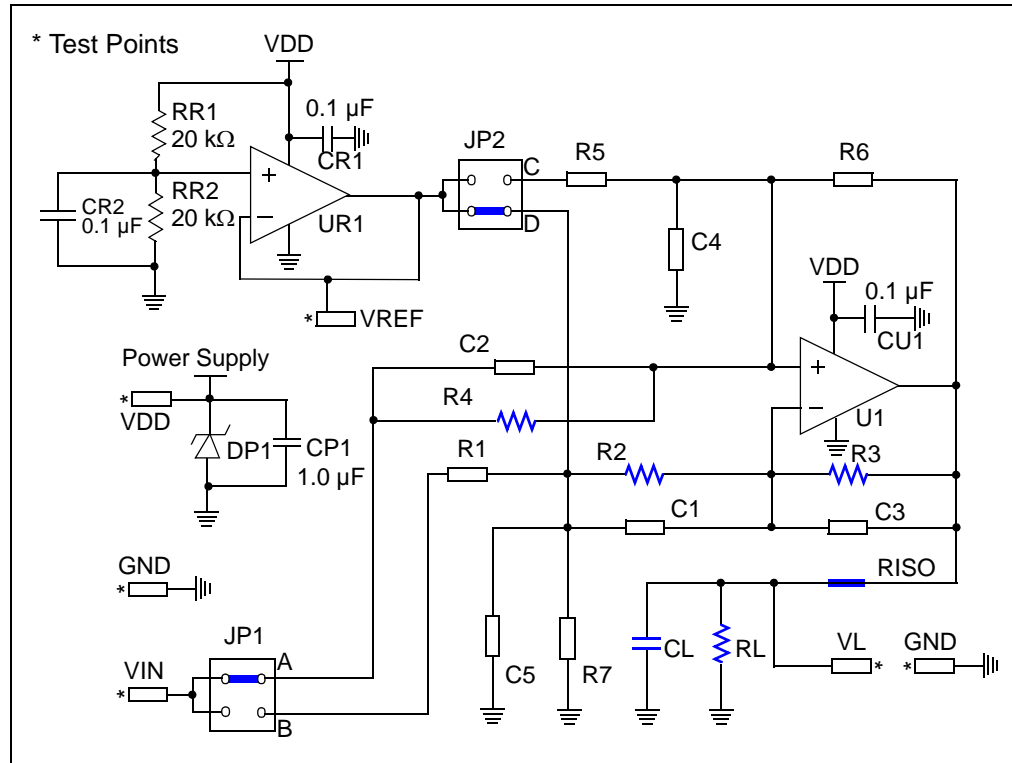

FIGURE 2-22: Fully Assembled Non-Inverting Amplifier Supported by the MCP6XXX Amplifier Evaluation Board 1.

The fully assembled MCP6XXX Amplifier Evaluation Board 1 top view is shown in Figure 2-23.

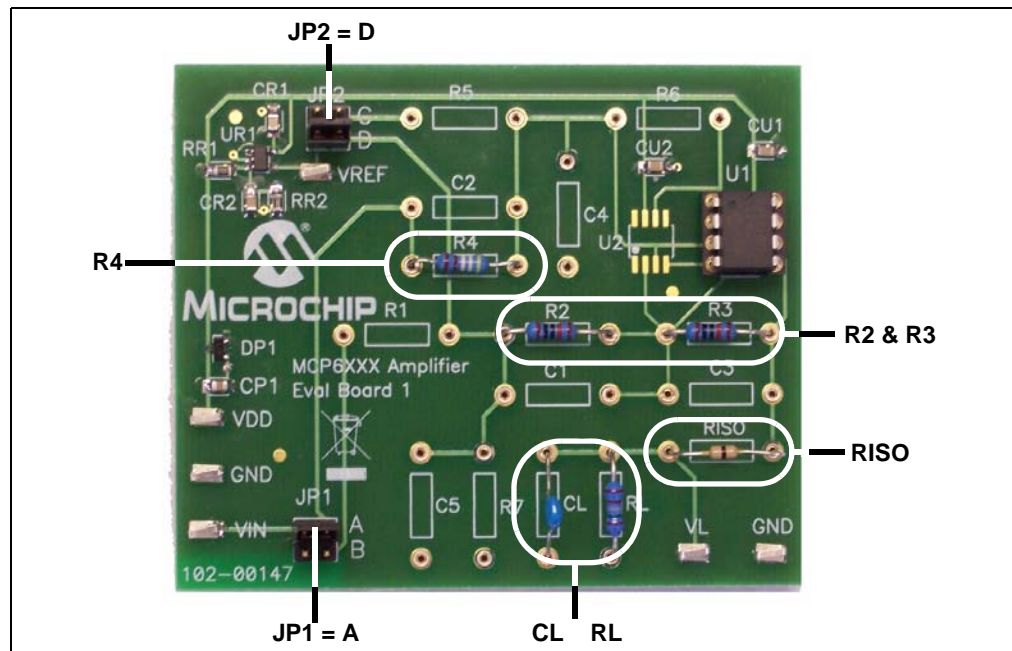

FIGURE 2-23: Picture of the Non-Inverting Amplifier Supported by the MCP6XXX Amplifier Evaluation Board 1.

2.4.2 Testing the Amplifier

2.4.2.1 CHECKING THE TEST POINTS

The (surface mount) test points for power supply, ground, input signal and output signal allow lab equipment to be connected to the board. Figure 2-24 shows the test points to check.

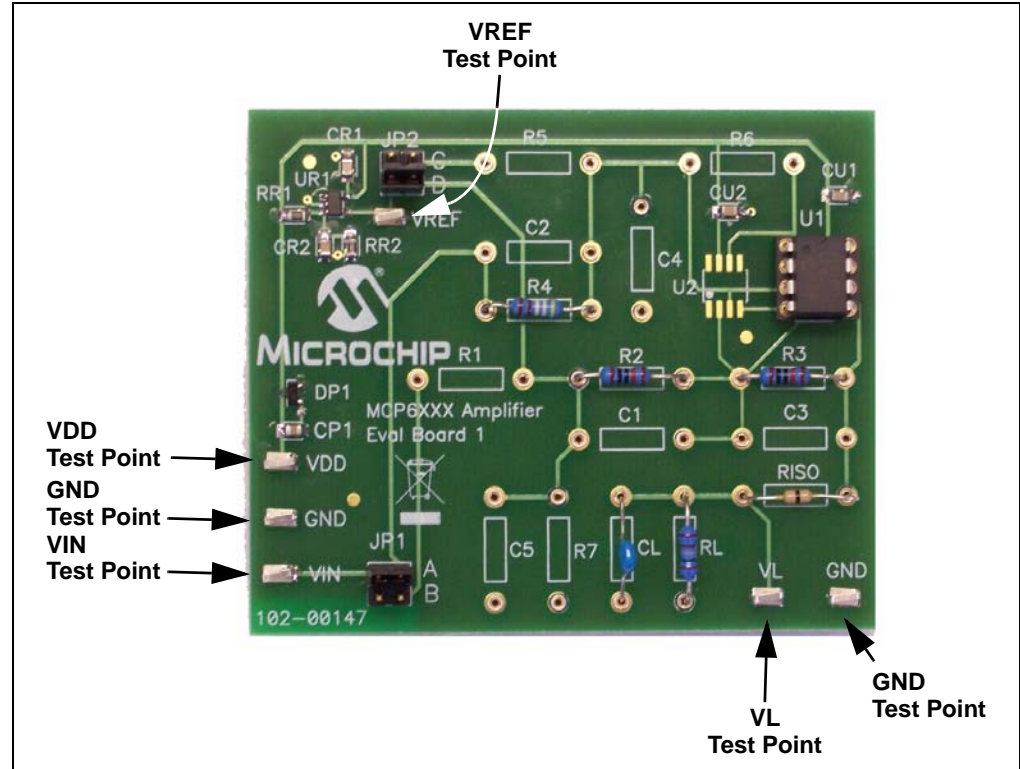

FIGURE 2-24: Checking the Test Points.

MCP6XXX Amplifier Evaluation Board 1 User's Guide

2.4.2.2 TRANSIENT RESPONSES

This non-inverting amplifier was built, and its responses were measured. A MCP6021 op amp, 1% resistors, and 5% capacitors were used. Notice how close the measured and simulated data are.

2.4.2.2.1 Step Response

In Bench Measurement:

- Set V_{IN} with a step amplitude of 2.0V and a center voltage of 2.5V. (i.e. V_{IN} starts 1.0V below center and ends 1.0V above center).
- The measured step response is shown in Figure 2-25. It is a signal with a step amplitude of 4.0V and an center voltage of 2.5V. (i.e. V_{OUT} starts 2.0V below center and ends 2.0V above center).

Note: The center voltage of V_{IN} is set at $V_{REF} = V_{DD}/2$ (For $V_{DD} = 5.0V$, $V_{REF} = 2.5V$)

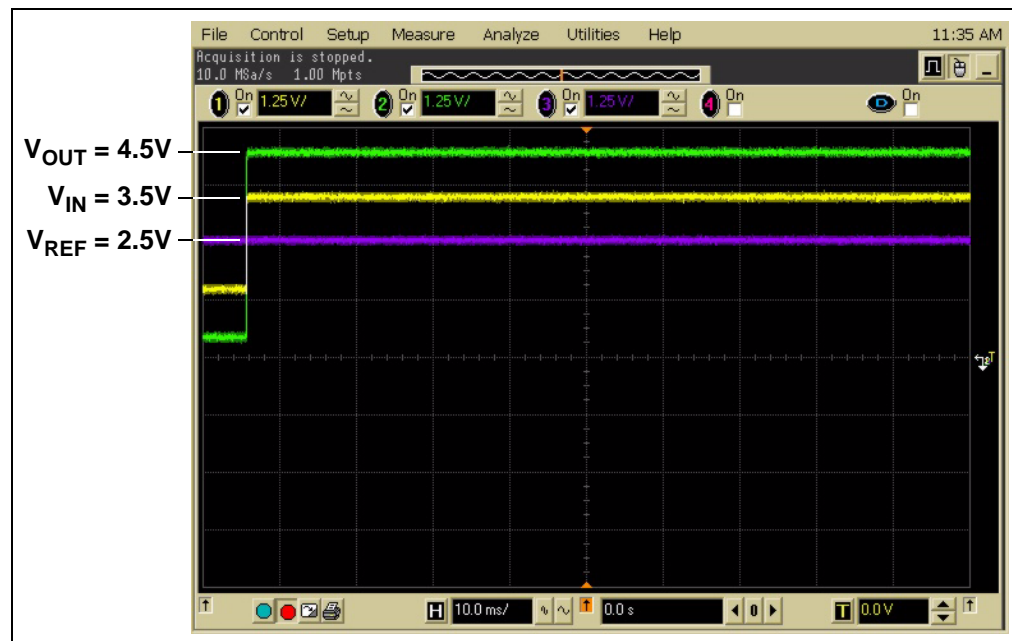

FIGURE 2-25: Measured Step Response.

Installation and Operation

In Mindi™ Amplifier Designer:

- Set V_{IN} with a step amplitude of 2.0V and a center voltage of 2.5V. (i.e. starts 1V below center and ends 1V above center)
- The simulated step response is shown in Figure 2-26. It is a signal with a step amplitude of 4.0V and an center voltage of 2.5V

Note: The center voltage of V_{IN} is set at $V_{REF} = V_{DD}/2$ (For $V_{DD} = 5.0V$, $V_{REF} = 2.5V$)

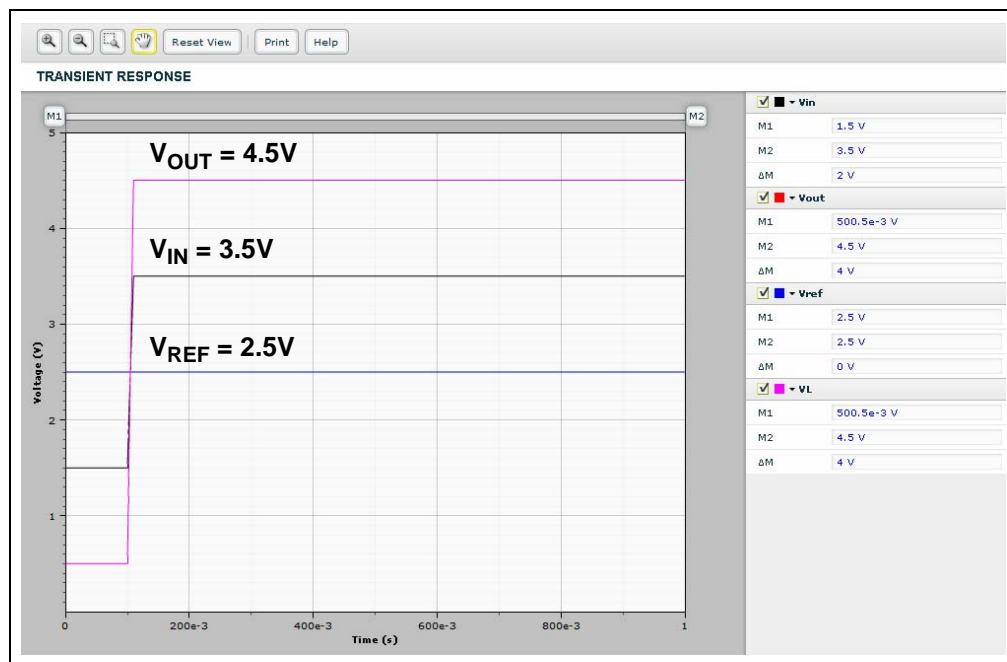

FIGURE 2-26: Simulated Step Response.

MCP6XXX Amplifier Evaluation Board 1 User's Guide

2.4.2.2.2 Sine Wave Response

In Bench Measurement:

- Set V_{IN} as a sine wave with a frequency of 100.0 Hz, a peak-to-peak voltage of 2.0V and a center voltage of 2.5V
- The measured sine wave response is shown in Figure 2-27. It is a sine wave signal with a frequency of 100.0 Hz, a peak-to-peak voltage of 4.0V and a center voltage of 2.5V

Note: The center voltage of V_{IN} is set at $V_{REF} = V_{DD}/2$ (For $V_{DD} = 5.0V$, $V_{REF} = 2.5V$)

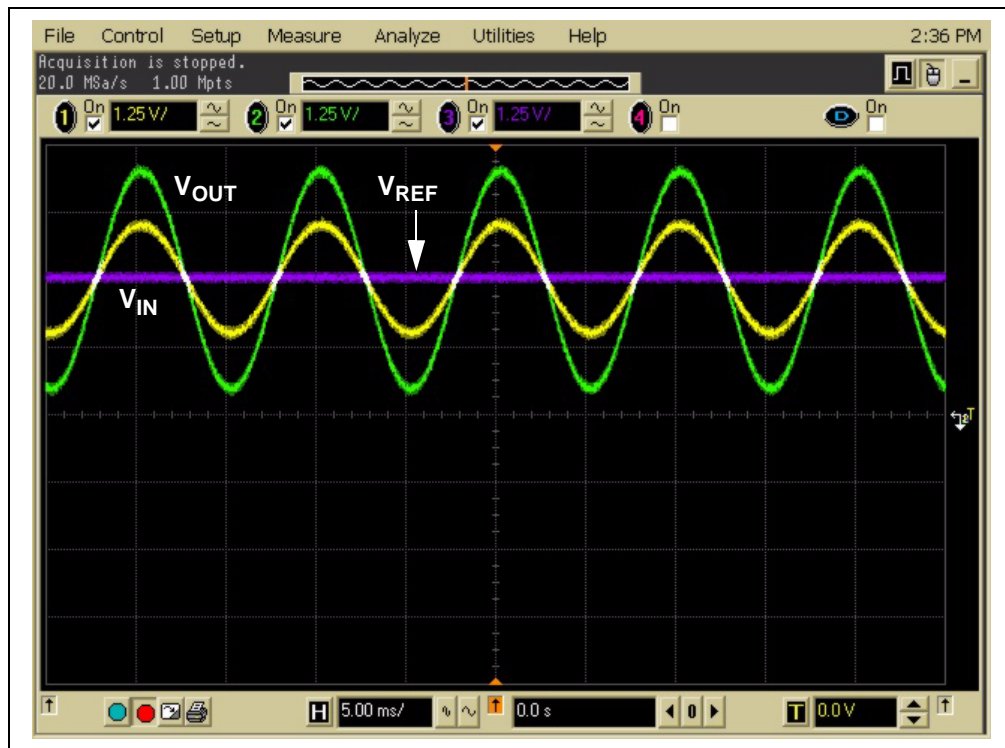

FIGURE 2-27: Measured Sine Wave Response.

Installation and Operation

In Mindi™ Amplifier Designer:

- Set V_{IN} as a sine wave with a frequency of 100.0 Hz, a peak-to-peak voltage of 2.0V and a center voltage of 2.5V
- The simulated sine wave response is shown in Figure 2-28. It is a sine wave signal with a frequency of 100.0 Hz, a peak-to-peak voltage of 4.0V and a center voltage of 2.5V

Note: The center voltage of V_{IN} is set at $V_{REF} = V_{DD}/2$ (For $V_{DD} = 5.0V$, $V_{REF} = 2.5V$)

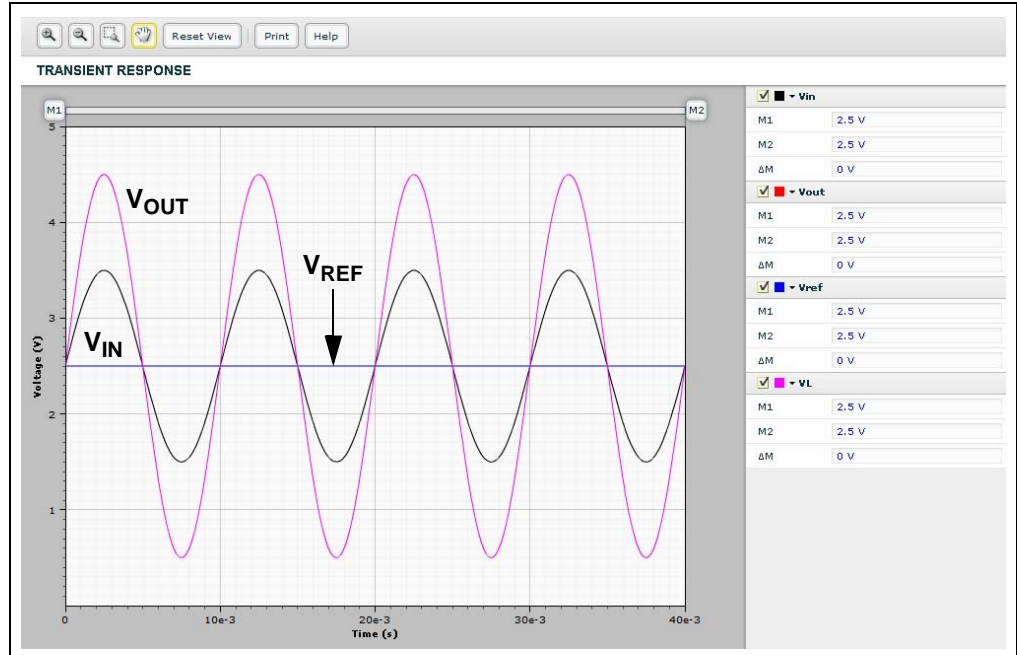

FIGURE 2-28: Simulated Sine Wave Response.

MCP6XXX Amplifier Evaluation Board 1 User's Guide

2.4.3 Amplifier Modification: Using 8-Pin SOIC Op Amps

There are two options available when using single op amps in SOIC-8 packages (150 mil wide):

- Soldering onto the MCP6XXX Amplifier Evaluation Board 1, or
- Soldering it onto a separate board which is connected to the DIP-8 socket

Note: The DIP-8 socket must be empty; only one op amp can be used at a time.

Figure 2-29 shows a SOIC-8 op amp soldered onto the MCP6XXX Amplifier Evaluation Board 1.

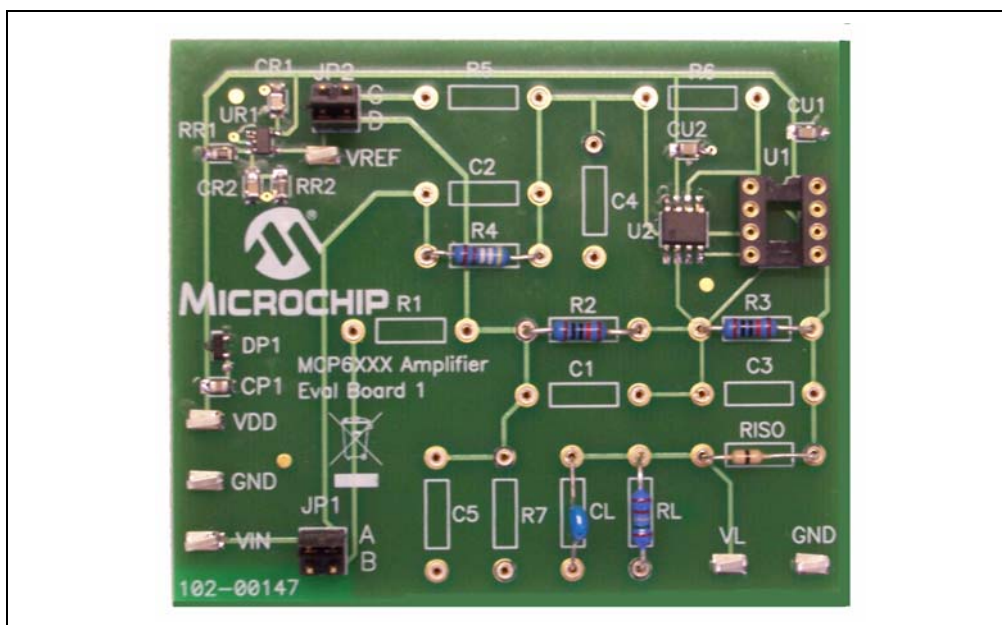

FIGURE 2-29: Op Amp in SOIC-8 package soldered onto the MCP6XXX Amplifier Evaluation Board 1.

Figure 2-30 shows a SOIC-8 op amp and a DIP-8 socket, soldered onto the 8-Pin SOIC/MSOP/TSSOP/DIP Evaluation Board available from Microchip Technology Inc (order # SOIC8EV). The two interconnect strips on the bottom are Samtec part # BBS-14-T-B or equivalent and are soldered into the through holes for the DIP-8 socket. Figure 2-31 shows the SOIC8EV board plugged into the MCP6XXX Amplifier Evaluation Board 1.

Note: Insert the interconnect strips into the DIP-8 socket on the MCP6XXX Amplifier Evaluation Board 1. Place the SOIC8EV board on the top of the interconnect strips with the same pin orientation. Now solder the strips to the top board; this procedure ensures correct alignment of the strips. Clip the pins flush with the top surface of the SOIC8EV board, then solder the SOIC-8 op amp on the top.

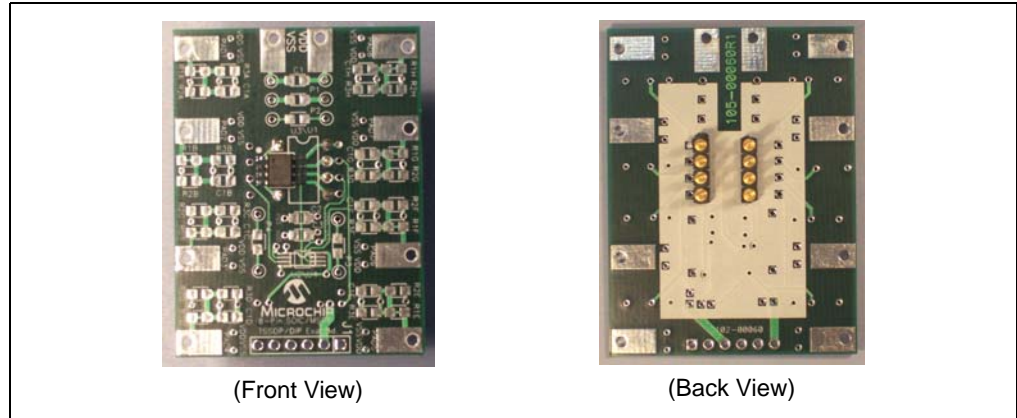

FIGURE 2-30: Op Amp in SOIC-8 Package Soldered onto a Separate Board.

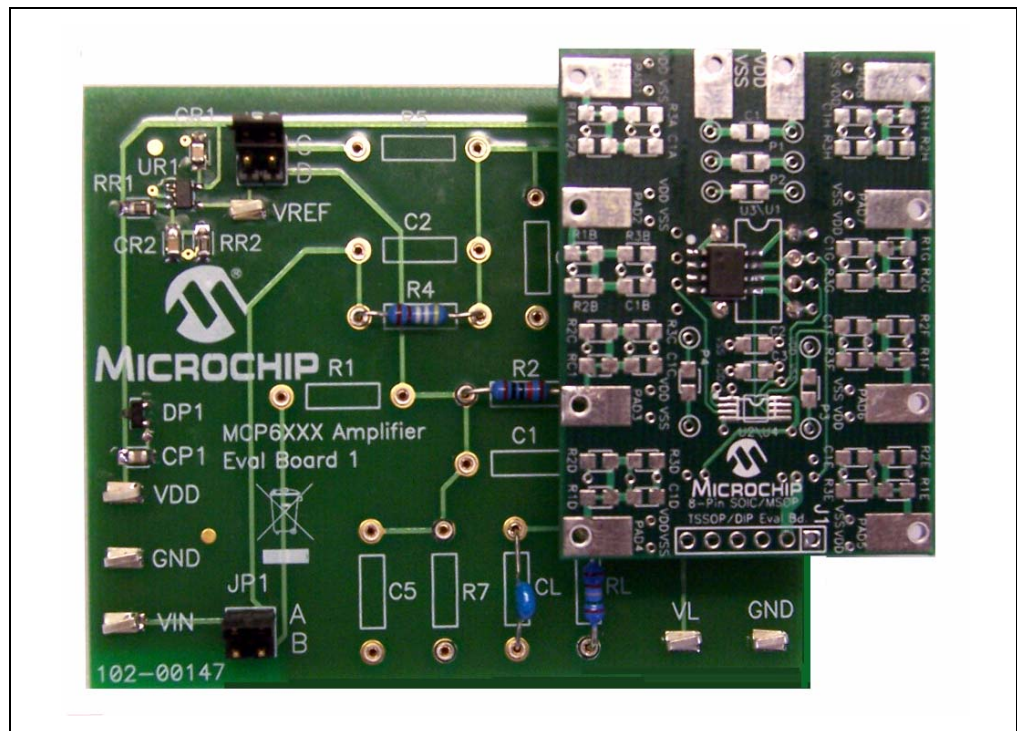

FIGURE 2-31: Connecting Adaptor Board onto the MCP6XXX Amplifier Evaluation Board 1.

MCP6XXX Amplifier Evaluation Board 1 User's Guide

NOTES:



MCP6XXX AMPLIFIER EVALUATION BOARD 1 USER'S GUIDE

Appendix A. Schematic and Layouts

A.1 INTRODUCTION

This appendix contains the following schematics and layouts for the MCP6XXX Amplifier Evaluation Board 1:

- Board – Schematic
- Board – Top Silk Layer
- Board – Top Metal Layer
- Board – Bottom Metal Layer

MCP6XXX Amplifier Evaluation Board 1 User's Guide

A.2 BOARD - SCHEMATIC

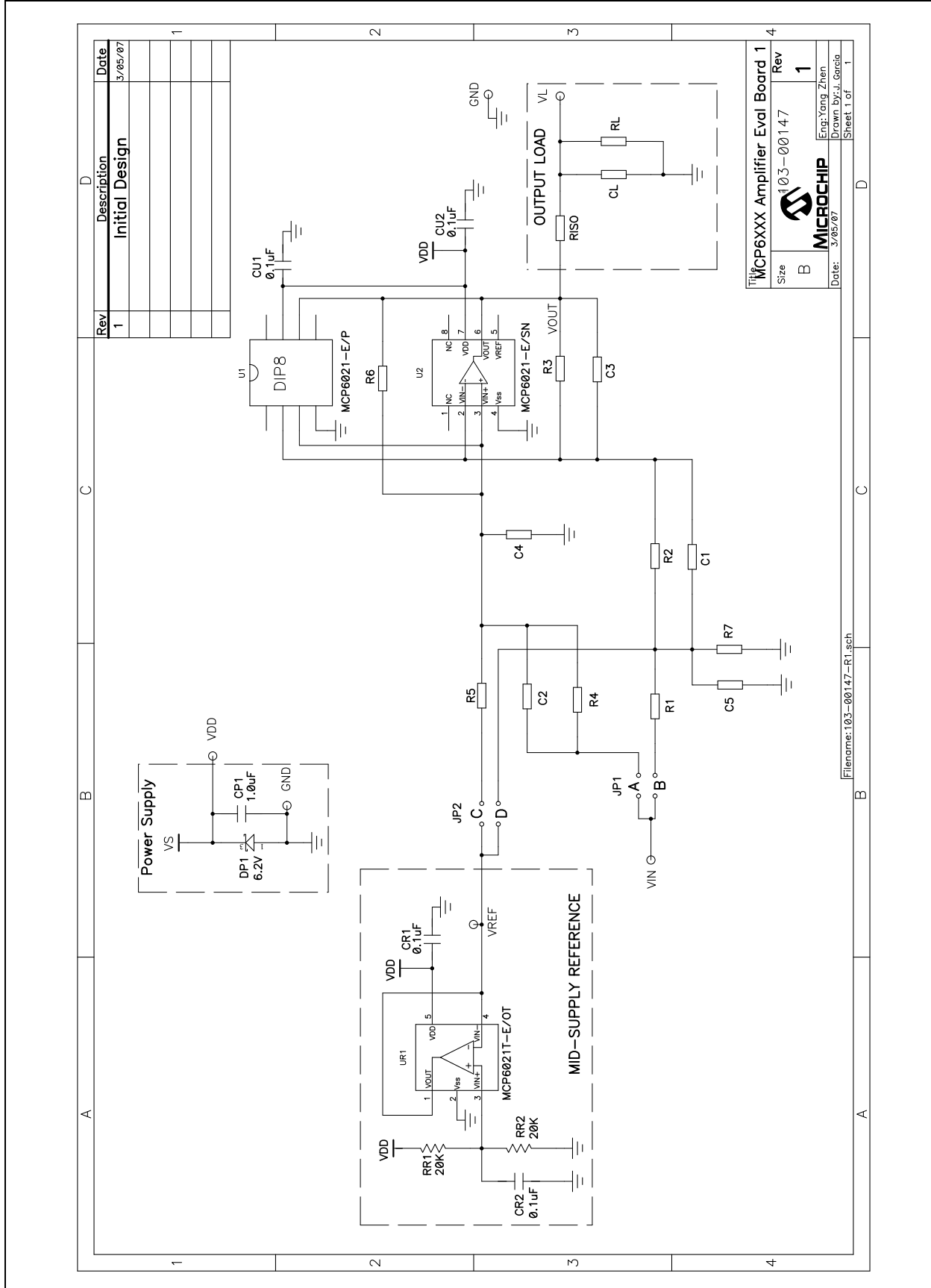

Filename: 103-00147-R1.sch

A.3 BOARD - TOP SILK LAYER

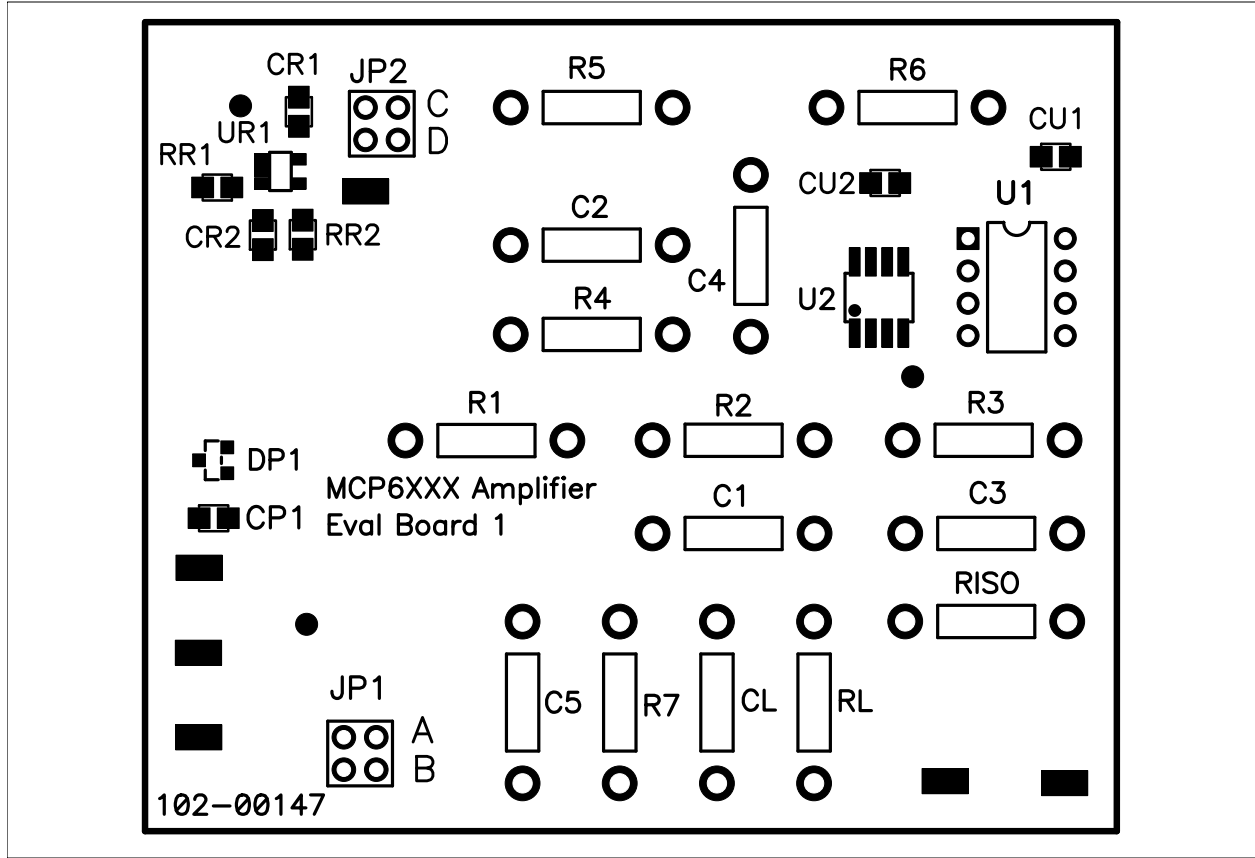

MCP6XXX Amplifier Evaluation Board 1 User's Guide

A.4 BOARD - TOP METAL LAYER

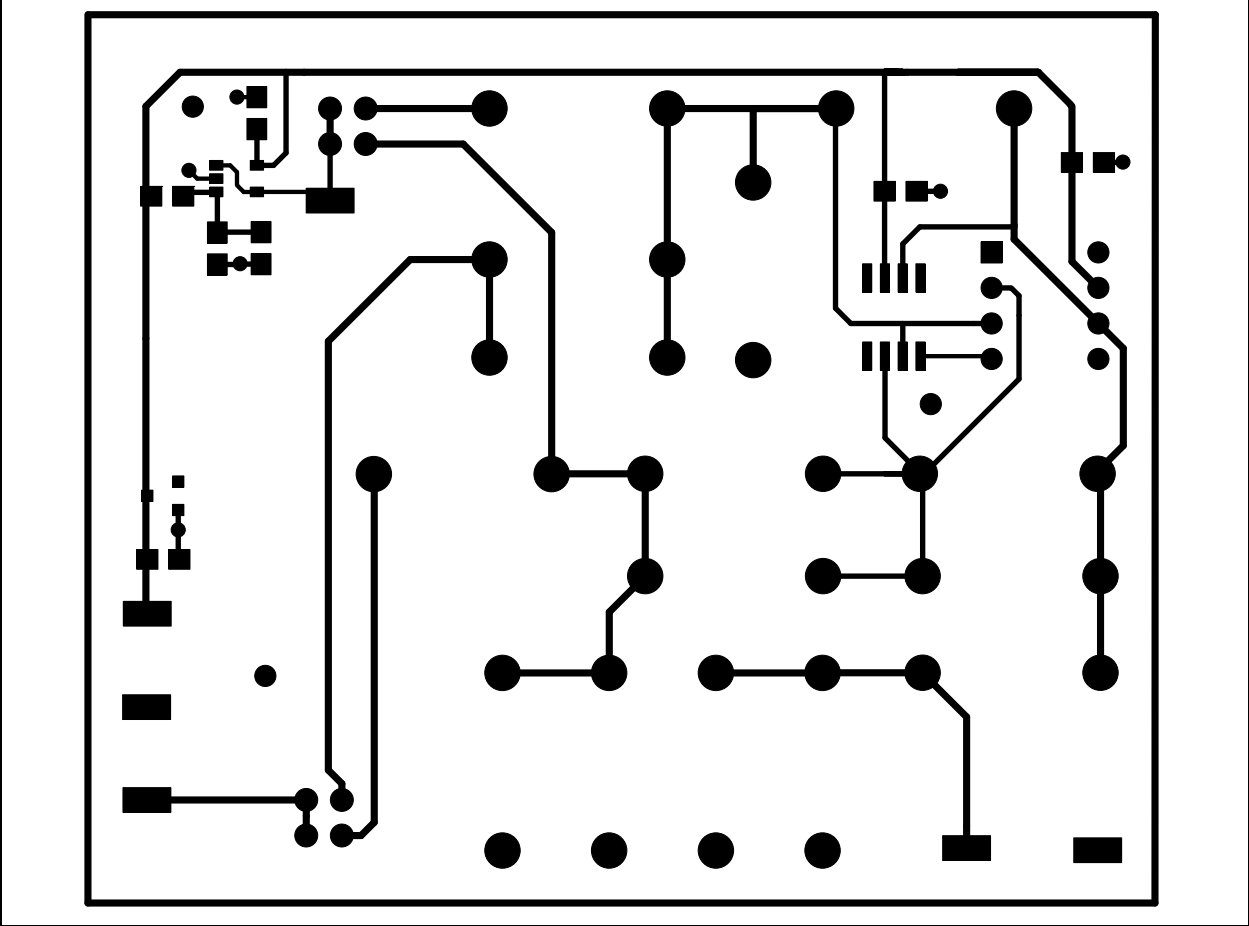

A.5 BOARD - BOTTOM METAL LAYER

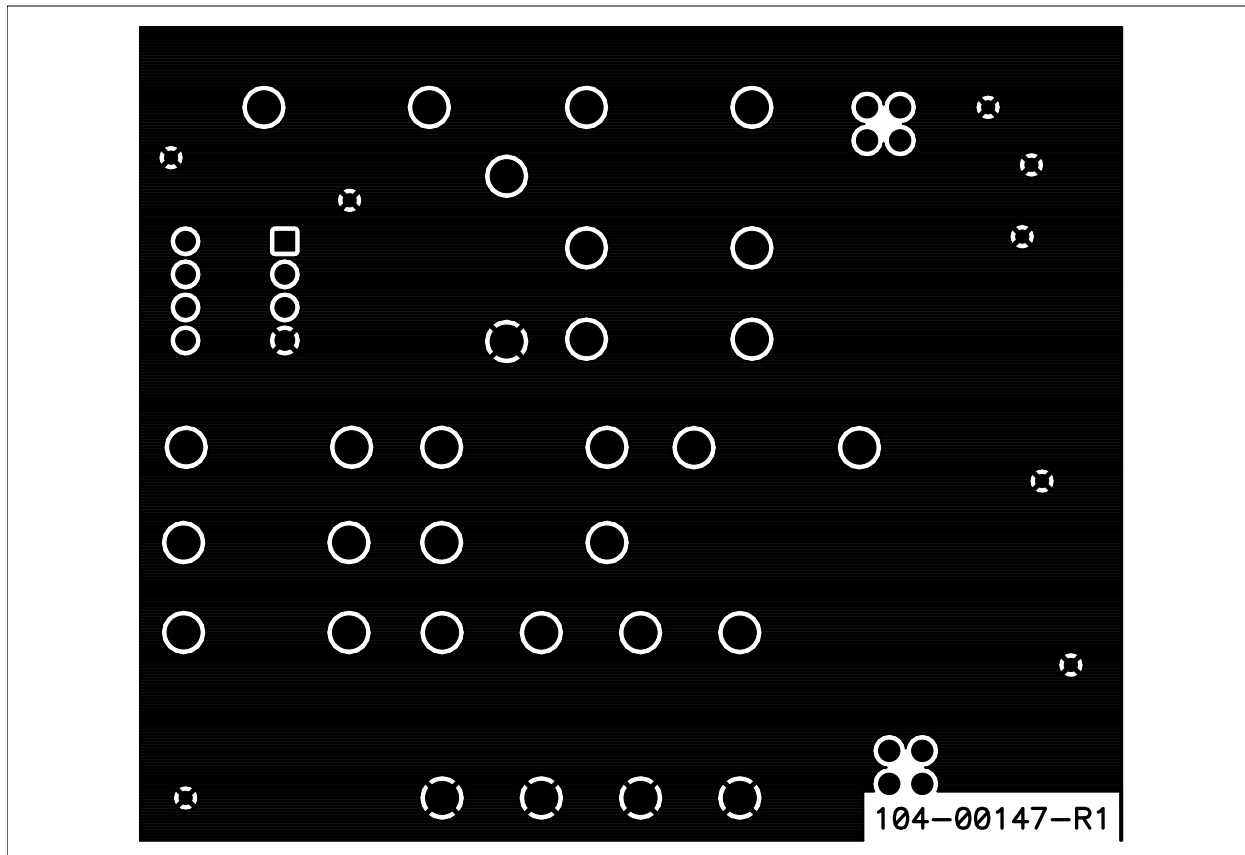

MCP6XXX Amplifier Evaluation Board 1 User's Guide

NOTES:



MCP6XXX AMPLIFIER EVALUATION BOARD 1 USER'S GUIDE

Appendix B. Bill Of Materials (BOM)

B.1 MCP6XXX AMPLIFIER EVALUATION BOARD 1 BOM

The Bill of Materials (BOM) in Table B-1 corresponds to Figure 2-1 and Figure 2-2. Unpopulated parts are in Table B-2.

TABLE B-1: BILL OF MATERIALS (102-00147R1) (NOTE 1)

Qty	Reference	Description	Manufacturer	Part Number
1	CP1	CAP CERAMIC 1UF 10% 25V X5R 0805	Panasonic® - ECG	ECJ-2FB1E105K
4	CR1, CR2, CU1, CU2	CAP CERAMIC .1UF 10% 25V X7R 0805	Panasonic - ECG	ECJ-2VB1E104K
1	DP1	DIODE ZENER 6.2V 350MW SOT-23	Fairchild Semiconductor	BZX84C6V2
4	EA Corner	BUMPER CLEAR .375X.15"DOME	Richco Plastic Co	RBS-12
2	J1, J2	CONN HEADR BRKWAY .100 04POS STR	Tyco Electronics/Amp	9-146258-0-02
1	PCB	RoHS Compliant Bare PCB, MCP6XXX Amplifier Evaluation Board 1	—	104-00147
30	Pin Socket	PIN RECPT .015/.025 DIA 0667 SER	Mill-Max®	0667-0-15-01-30-27-10-0
2	RR1, RR2	RES 20.0K OHM 1/8W 1% 0805 SMD	Panasonic - ECG	ERJ-6ENF2002V
2	Shunts for J1&J2	SOCKET,SHORT BLKS W TAB BLK	JAMECO VALUEPRO	2012JH-R
6	Test Points	PC TEST POINT COMPACT SMT	Keystone Electronics	5016
1	UR1	MCP6021 SOT-23-5 Single Op Amp	Microchip Technology Inc.	MCP6021T-E/OT
1	U1 Socket	CONN IC SOCKET 8POS DIP TIN	Tyco Electronics/Amp	2-641260-1

Note 1: The components listed in this Bill of Materials are representative of the PCB assembly. The released BOM used in manufacturing uses all RoHS-compliant components.

Bill Of Materials (BOM)

TABLE B-2: BILL OF MATERIALS – UNPOPULATED PARTS (102-00147R1)

Qty	Reference	Description	Manufacturer	Part Number
1	U1	MCP6021 PDIP-8, Single Op Amp	Microchip Technology Inc.	MCP6021-E/P
1	U2	MCP6021 SOIC-8, Single Op Amp	Microchip Technology Inc.	MCP6021-E/SN
15	R1-R7, RISO, RL C1-C5, CL	Not Populated when shipped to customer	—	—

Note 1: The components listed in this Bill of Materials are representative of the PCB assembly. The released BOM used in manufacturing uses all RoHS-compliant components.

The BOM in Table B-3 corresponds to the collection of resistors, capacitors, jumpers and MCP6021 op amps that come in the Accessory Bag which is shipped in the MCP6XXX Amplifier Evaluation Board 1 Kit. These components are placed in a separate ESD bag. They support the circuit in **Section 2.4.1 “Building the Amplifier”**. Customers need to provide the resistors and capacitors for more amplifier circuits.

TABLE B-3: BILL OF MATERIALS – ACCESSORY BAG PARTS (102-00147R1)

Qty	Reference	Description	Manufacturer	Part Number
1	Accessory Bag	CAP CER 56PF 50V COG RADIAL	Murata Electronics	RPE5C1H560J2P1Z03B
1	Accessory Bag	JUMPER ZERO OHM 1/8W	Yageo Corporation	ZOR-12-B-52
1	Accessory Bag	RES 976 OHM 1/4W 1% METAL FILM	Yageo Corporation	MFR-25FBB-976R
1	Accessory Bag	RES 3.92K OHM 1/4W 1% METAL FILM	Yageo Corporation	MFR-25FBB-3K92
2	Accessory Bag	RES 1.96K OHM 1/4W 1% METAL FILM	Yageo Corporation	MFR-25FBB-1K96
1	ESD Sample Box	MCP6021 Single Op Amp PDIP-8	Microchip Technology Inc.	MCP6021-E/P

Note 1: The components listed in this Bill of Materials are representative of the PCB assembly. The released BOM used in manufacturing uses all RoHS-compliant components.

Bill Of Materials (BOM)

NOTES:



WORLDWIDE SALES AND SERVICE

AMERICAS

Corporate Office
2355 West Chandler Blvd.
Chandler, AZ 85224-6199
Tel: 480-792-7200
Fax: 480-792-7277
Technical Support:
<http://support.microchip.com>
Web Address:
www.microchip.com

Atlanta
Duluth, GA
Tel: 678-957-9614
Fax: 678-957-1455

Boston
Westborough, MA
Tel: 774-760-0087
Fax: 774-760-0088

Chicago
Itasca, IL
Tel: 630-285-0071
Fax: 630-285-0075

Dallas
Addison, TX
Tel: 972-818-7423
Fax: 972-818-2924

Detroit
Farmington Hills, MI
Tel: 248-538-2250
Fax: 248-538-2260

Kokomo
Kokomo, IN
Tel: 765-864-8360
Fax: 765-864-8387

Los Angeles
Mission Viejo, CA
Tel: 949-462-9523
Fax: 949-462-9608

Santa Clara
Santa Clara, CA
Tel: 408-961-6444
Fax: 408-961-6445

Toronto
Mississauga, Ontario,
Canada
Tel: 905-673-0699
Fax: 905-673-6509

ASIA/PACIFIC

Asia Pacific Office
Suites 3707-14, 37th Floor
Tower 6, The Gateway
Harbour City, Kowloon
Hong Kong
Tel: 852-2401-1200
Fax: 852-2401-3431

Australia - Sydney
Tel: 61-2-9868-6733
Fax: 61-2-9868-6755

China - Beijing
Tel: 86-10-8528-2100
Fax: 86-10-8528-2104

China - Chengdu
Tel: 86-28-8665-5511
Fax: 86-28-8665-7889

China - Fuzhou
Tel: 86-591-8750-3506
Fax: 86-591-8750-3521

China - Hong Kong SAR
Tel: 852-2401-1200
Fax: 852-2401-3431

China - Qingdao
Tel: 86-532-8502-7355
Fax: 86-532-8502-7205

China - Shanghai
Tel: 86-21-5407-5533
Fax: 86-21-5407-5066

China - Shenyang
Tel: 86-24-2334-2829
Fax: 86-24-2334-2393

China - Shenzhen
Tel: 86-755-8203-2660
Fax: 86-755-8203-1760

China - Shunde
Tel: 86-757-2839-5507
Fax: 86-757-2839-5571

China - Wuhan
Tel: 86-27-5980-5300
Fax: 86-27-5980-5118

China - Xian
Tel: 86-29-8833-7252
Fax: 86-29-8833-7256

ASIA/PACIFIC

India - Bangalore
Tel: 91-80-4182-8400
Fax: 91-80-4182-8422

India - New Delhi
Tel: 91-11-4160-8631
Fax: 91-11-4160-8632

India - Pune
Tel: 91-20-2566-1512
Fax: 91-20-2566-1513

Japan - Yokohama
Tel: 81-45-471- 6166
Fax: 81-45-471-6122

Korea - Daegu
Tel: 82-53-744-4301
Fax: 82-53-744-4302

Korea - Seoul
Tel: 82-2-554-7200
Fax: 82-2-558-5932 or
82-2-558-5934

Malaysia - Penang
Tel: 60-4-646-8870
Fax: 60-4-646-5086

Philippines - Manila
Tel: 63-2-634-9065
Fax: 63-2-634-9069

Singapore
Tel: 65-6334-8870
Fax: 65-6334-8850

Taiwan - Hsin Chu
Tel: 886-3-572-9526
Fax: 886-3-572-6459

Taiwan - Kaohsiung
Tel: 886-7-536-4818
Fax: 886-7-536-4803

Taiwan - Taipei
Tel: 886-2-2500-6610
Fax: 886-2-2508-0102

Thailand - Bangkok
Tel: 66-2-694-1351
Fax: 66-2-694-1350

EUROPE

Austria - Wels
Tel: 43-7242-2244-39
Fax: 43-7242-2244-393

Denmark - Copenhagen
Tel: 45-4450-2828
Fax: 45-4485-2829

France - Paris
Tel: 33-1-69-53-63-20
Fax: 33-1-69-30-90-79

Germany - Munich
Tel: 49-89-627-144-0
Fax: 49-89-627-144-44

Italy - Milan
Tel: 39-0331-742611
Fax: 39-0331-466781

Netherlands - Drunen
Tel: 31-416-690399
Fax: 31-416-690340

Spain - Madrid
Tel: 34-91-708-08-90
Fax: 34-91-708-08-91

UK - Wokingham
Tel: 44-118-921-5869
Fax: 44-118-921-5820

06/25/07

Компания «Life Electronics» занимается поставками электронных компонентов импортного и отечественного производства от производителей и со складов крупных дистрибьюторов Европы, Америки и Азии.

С конца 2013 года компания активно расширяет линейку поставок компонентов по направлению коаксиальный кабель, кварцевые генераторы и конденсаторы (керамические, пленочные, электролитические), за счёт заключения дистрибьюторских договоров

Мы предлагаем:

- Конкуренспособные цены и скидки постоянным клиентам.
- Специальные условия для постоянных клиентов.
- Подбор аналогов.
- Поставку компонентов в любых объемах, удовлетворяющих вашим потребностям.
- Приемлемые сроки поставки, возможна ускоренная поставка.
- Доставку товара в любую точку России и стран СНГ.
- Комплексную поставку.
- Работу по проектам и поставку образцов.
- Формирование склада под заказчика.
- Сертификаты соответствия на поставляемую продукцию (по желанию клиента).
- Тестирование поставляемой продукции.
- Поставку компонентов, требующих военную и космическую приемку.
- Входной контроль качества.
- Наличие сертификата ISO.

В составе нашей компании организован Конструкторский отдел, призванный помогать разработчикам, и инженерам.

Конструкторский отдел помогает осуществить:

- Регистрацию проекта у производителя компонентов.
- Техническую поддержку проекта.
- Защиту от снятия компонента с производства.
- Оценку стоимости проекта по компонентам.
- Изготовление тестовой платы монтаж и пусконаладочные работы.



Тел: +7 (812) 336 43 04 (многоканальный)

Email: org@lifeelectronics.ru