

NEW

microSD™ Card Connectors

DM3 Series

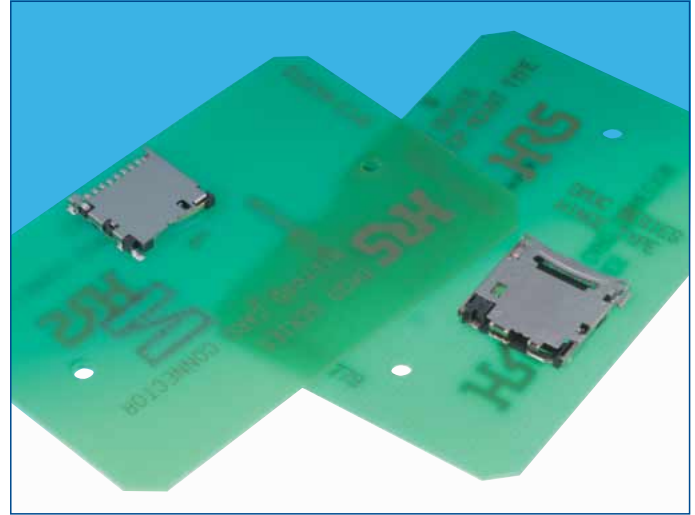

■ Features

◆ Common to the entire Series

1. Extremely small size

Small external dimensions and the above-the-board height make the connectors the smallest on the market.

2. Reverse card insertion protection

Unique card slot design (patented) protects the connector from damage when the card is attempted to be inserted in reverse, allowing it to re-inserted correctly.

3. Effective ground and shield configuration

4-connection points of the metal cover to the printed circuit board assures secure connection of the ground circuit and provides EMI protection.

4. Rigid and strong construction

Despite its small size, high-strength materials used in the connectors produced a strong and rigid structure.

5. Card detection switch

The card detection switch is Normally Open

◆ DM3AT and DM3BT (Push - Push, with ejection mechanism)

• Card fall-out prevention

Built-in card tray and the unique push insertion-push ejection mechanism (patented) prevent accidental card ejection or fall-out.

Despite its small size the connectors will eject the card to a distance of 4.0 mm, allowing easy hold and removal of the card.

• Exposed termination leads

Easy inspection and rework of the solder termination joints.

◆ DM3CS (Hinge, Push-Pull, manual, without ejection mechanism)

• Simple and reliable card insertion

Hinged metal cover provides location and guides the card during the insertion / removal. Closing of the cover confirms the electrical and mechanical connection with a tactile click sensation.

• Reliable contact with the card contact pads

Unique contact design and card slide action will clean the contact areas of the card.

• Accessible termination areas

Contact solder terminations may be inspected and reworked.



◆ DM3D (Push -Pull, manual, without ejection mechanism)

• Partial card insertion hold

Card will not fall-out even when it is not fully inserted. Full insertion and electrical / mechanical connection is confirmed with a distinct tactile feel.

• Accessible termination areas

An inner lead system that can be reworked is used in this design. Contact solder terminations may be inspected and reworked.

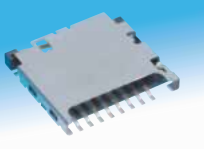
Card insertion-ejection	Series	Image	Page
Push-Push	DM3AT		2~4
	DM3BT		5~6
Hinge-manual insertion/ejection	DM3CS		7~8
Push-Pull manual insertion/ejection	DM3D		9~10

■ Specifications(DM3 Series)

Ratings	Current rating: 0.5A Voltage rating: 125V AC	Operating temperature range: -25°C to +85°C (Note 1) Storage temperature range : -40°C to +85°C (Note 2)	Operating humidity range: RH 95% max. (No condensation)
----------------	---	---	--

Item	Specification	Conditions
1. Insulation resistance	1000 MΩ min. (Initial value)	Measure at 500 V DC
2. Withstanding voltage	No flashover or insulation breakdown	500 V AC / 1 minute
3. Contact resistance	100mΩ max. (Initial value)	1mA
4. Vibration	No electrical discontinuity of 100 ns or longer No damage, cracks or parts dislocation.	Frequency: 10 to 55 Hz, single amplitude of 0.75 mm, 3 directions for 2 hours
5. Humidity	Contact resistance: 40 mΩ max. (change from initial value) Insulation resistance: 100 MΩ min. No damage, cracks or parts dislocation.	96 hours at of 40 ± 2°C, and humidity of 90 to 95%
6. Temperature cycle	Contact resistance: 40 mΩ max. (change from initial value) Insulation resistance: 100 MΩ min. No damage, cracks or parts dislocation.	-55°C → 5 to 35°C → 85°C → 5 to 35°C Times: 30 min. → 5 min. → 30 min. → 5 min. 5 cycles
7. Durability	Contact resistance: 40 mΩ max. (change from initial value)	10,000 cycles, 400 to 600 cycles per hour (DM3AT, DM3B) 5,000 cycles, 400 to 600 cycles per hour (DM3C, DM3D)
8. Resistance to soldering heat	No deformation of components affecting performance.	Reflow : At the recommended temperature profile Manual soldering : 350°C for 3 seconds

Note 1: Includes temperature rise caused by current flow.

Note 2. The term "storage" refers to products stored for long period prior to mounting and use.

■ Materials and Finishes

DM3AT, DM3BT

Part	Material	Finish	Remarks
Insulator	LCP	Color: Black	UL94V-0
Contacts	Copper alloy	Contact area: Gold plated Lead area: Gold plated	_____
Guide cover	Stainless steel (DM3AT) Copper alloy (DM3BT)	Lead area: Gold plated	_____
Other components	Stainless steel (DM3AT, DM3BT) Piano wire (DM3BT)	_____ Nickel plated	_____

DM3CS, DM3D

Part	Material	Finish	Remarks
Insulator	LCP	Color: Black	UL94V-0
Contacts	Copper alloy	Contact area: Gold plated Lead area: Gold plated	_____
Guide cover	Stainless steel	Tin plated	_____

■ Ordering information

DM3 AT – SF – PEJM5

① ② ③ ④

① Series name: DM3	③ Termination type : SF Right-angle SMT(Standard) DSF Right-angle SMT(Reverse)
② Connector type : AT Push-Push (ejection mechanism), Top board mounting (Standard) BT Push-Push (ejection mechanism), Bottom board mounting (Reverse) CS Hinge, Push-Pull (no ejection mechanism), Top board mounting (Standard) D Push-Pull (no ejection mechanism), Top board mounting (Standard) Number of contacts : 8	
	④ Card ejection code : PEJM5, PEJS (Push insert/push eject) None : Manual card insertion/ejection

DM3AT Push-Push (ejection mechanism), Top board mounting (Standard)



Part number	CL No.
DM3AT-SF-PEJM5	609-0031-0

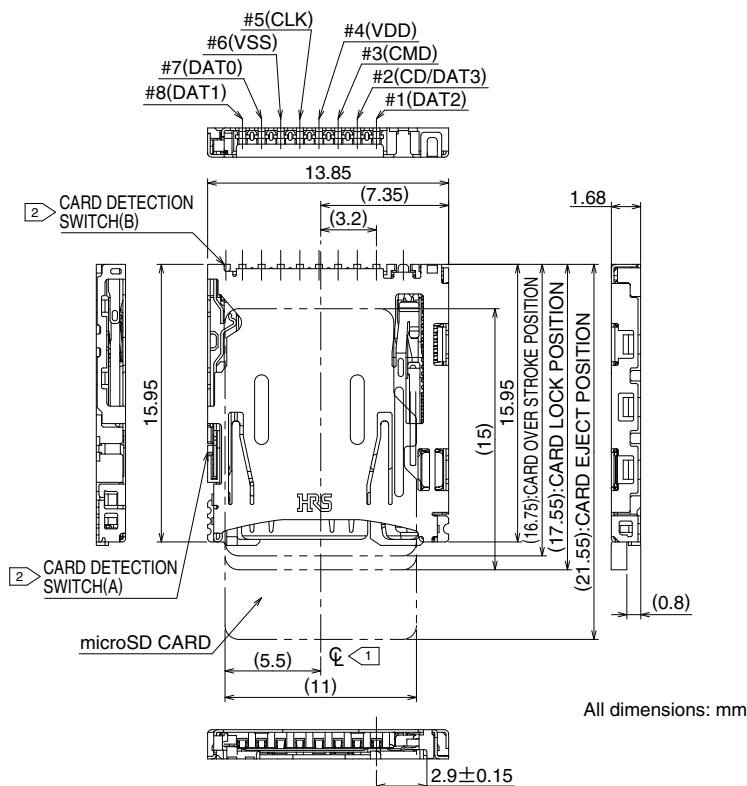

Recommended PCB mounting pattern

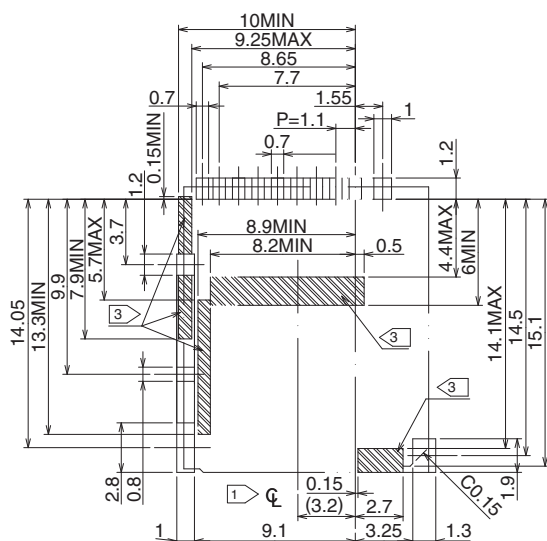

Note 1 ϕ indicates the center line of the microUSB card slot.

Card detection switch			
Without the card		Card inserted	
Open	Closed	Open	Closed
(A) (B)	(A) (B)	(A) (B)	(A) (B)

3 No conductive traces.

All dimensions: mm

Example of applications

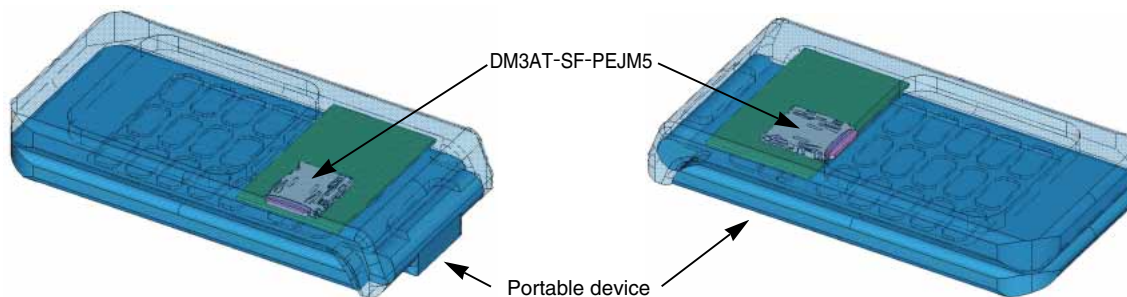

■ Packaging Specifications

- Embossed carrier tape dimensions (1,500 pieces per reel)

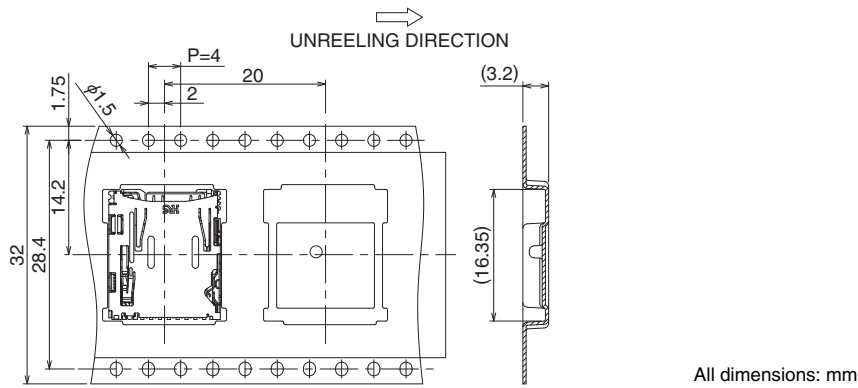

- Reel Dimensions

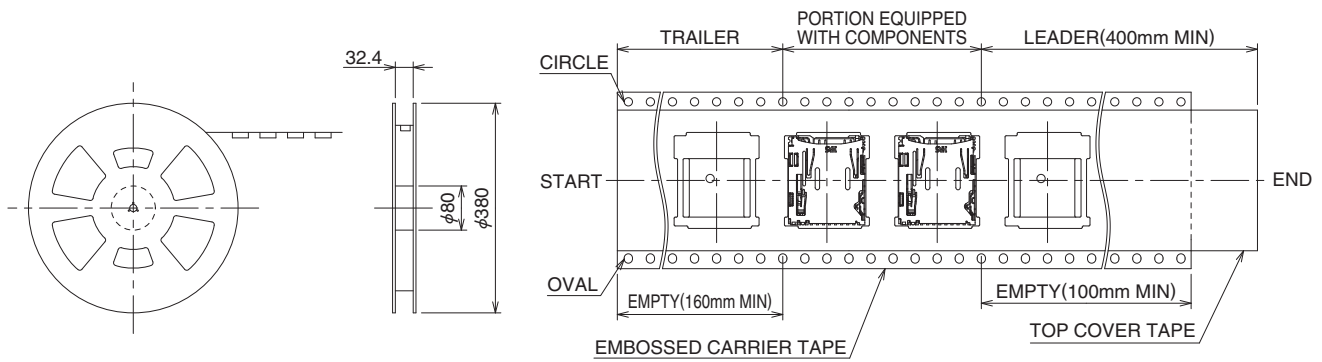

DM3BT, Push-Push (ejection mechanism), Bottom board mounting (Reverse)



Part number	CL No.
DM3BT-DSF-PEJS	609-0029-9

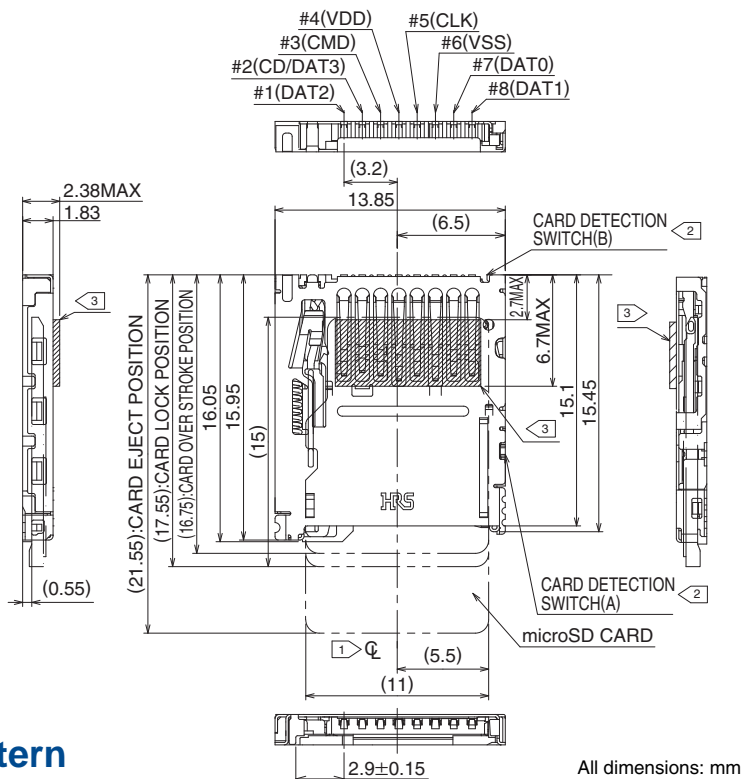

Recommended PCB mounting pattern

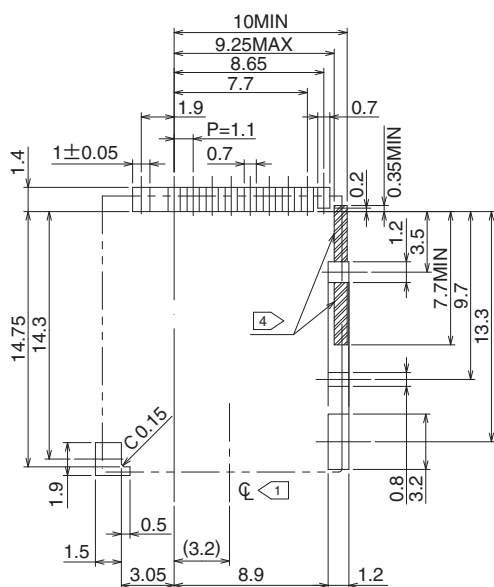

Note 1 Φ indicates the center line of the microSD card slot.

Card detection switch	
Without the card	Card inserted
Open	Closed
(A) (B)	(A) (B)

3 Oblique-hatched area is projection of contact.

4 No conductive traces.

All dimensions: mm

Example of applications

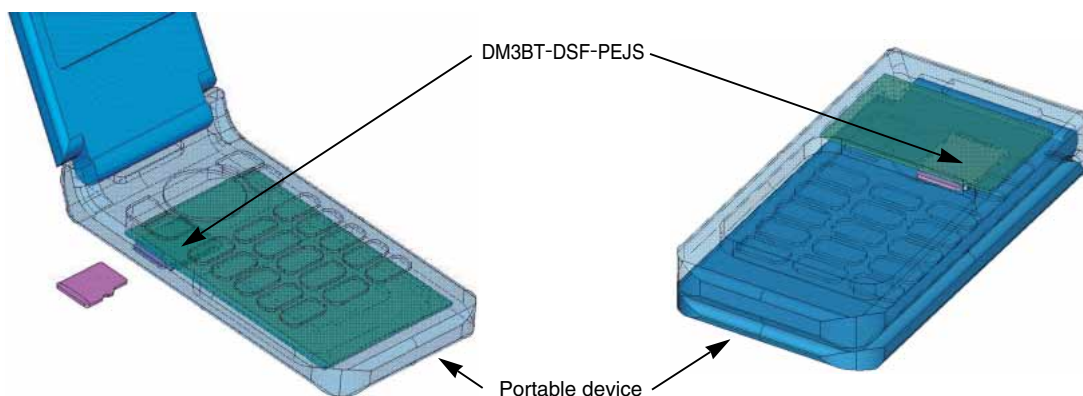

■ Packaging Specifications

- Embossed carrier tape dimensions (1,200pieces per reel)

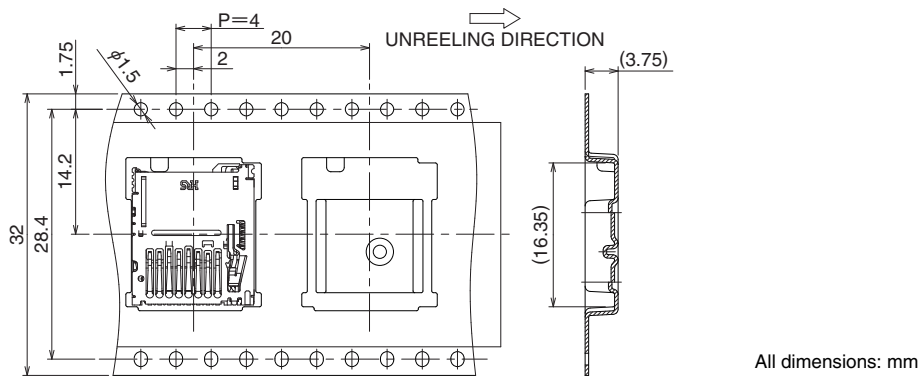

- Reel Dimensions

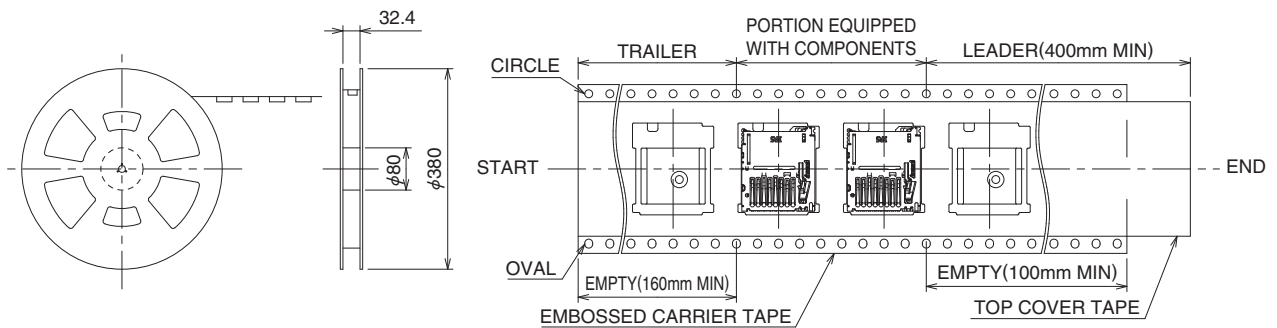

DM3CS, Hinge, Push -Pull (no ejection mechanism), Top board mounting (Standard)

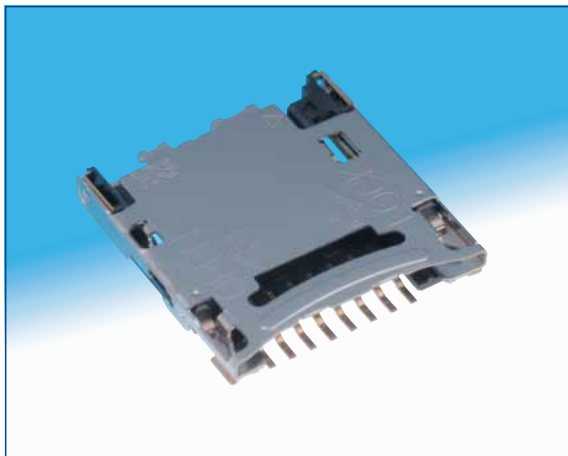

Part number	CL No.
DM3CS-SF	609-0032-3

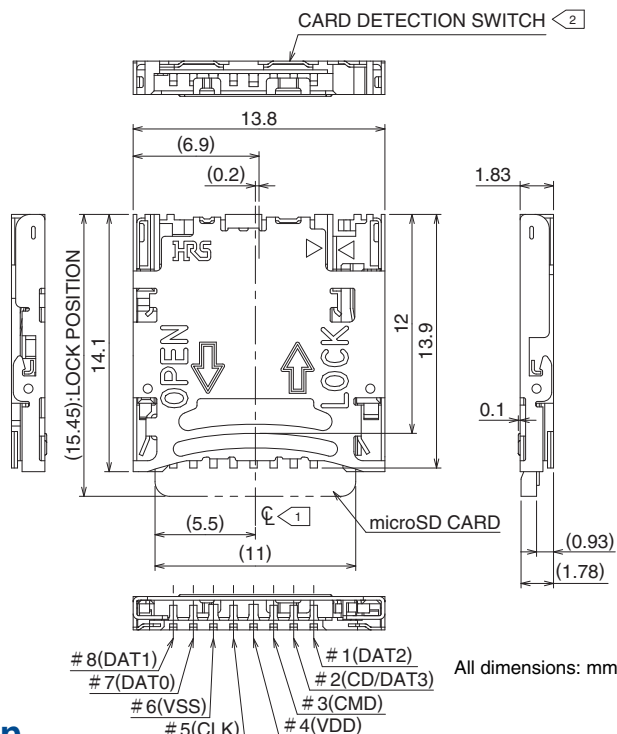

Recommended PCB mounting pattern

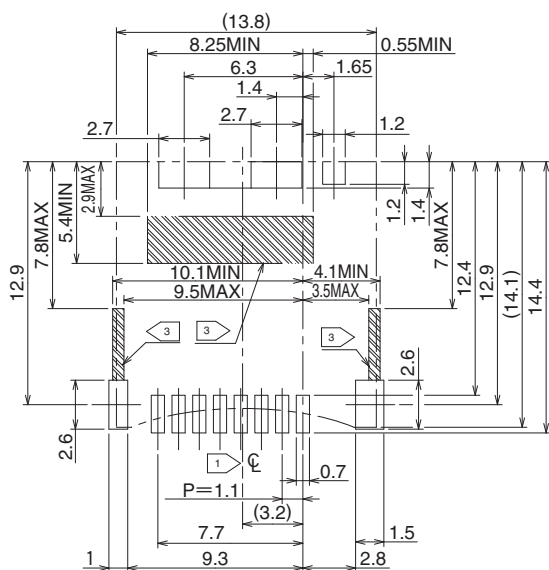

Note 1 ϕ indicates the center line of the microSD card slot.

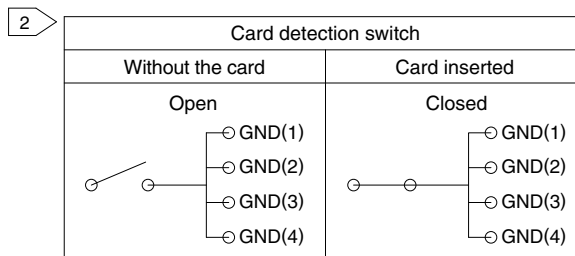

Note 3 No conductive traces.

All dimensions: mm

Example of Use applications

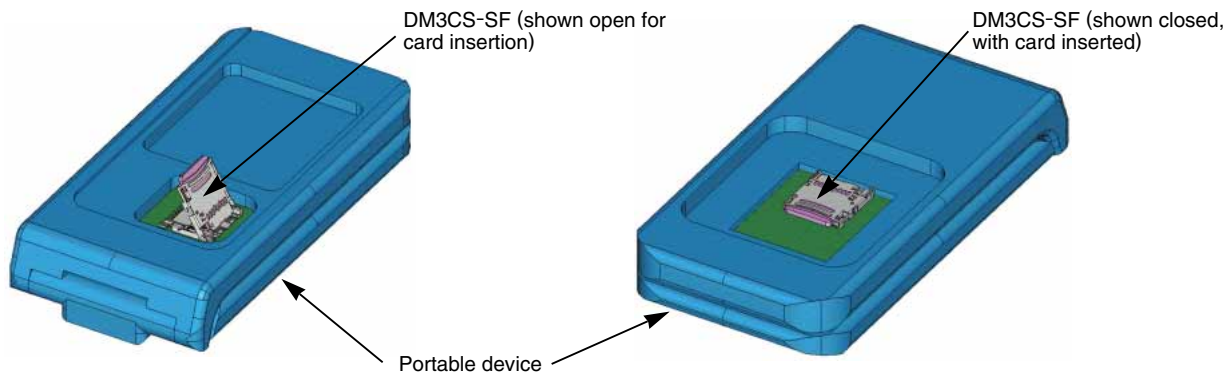

■ Packaging Specifications

- Embossed carrier tape dimensions (1,300pieces per reel)

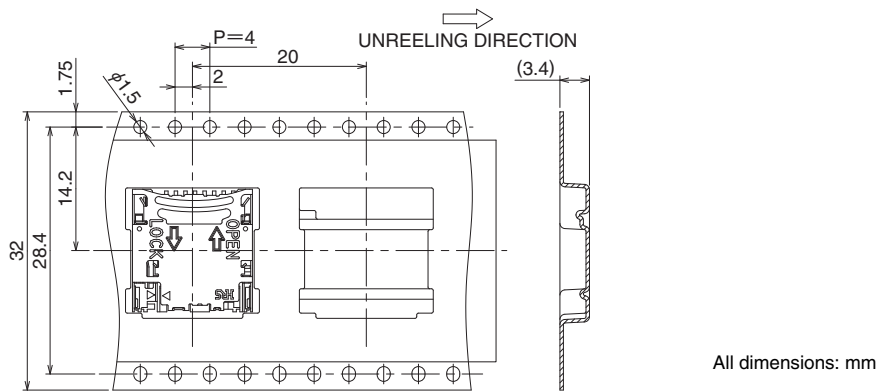

- Reel Dimensions

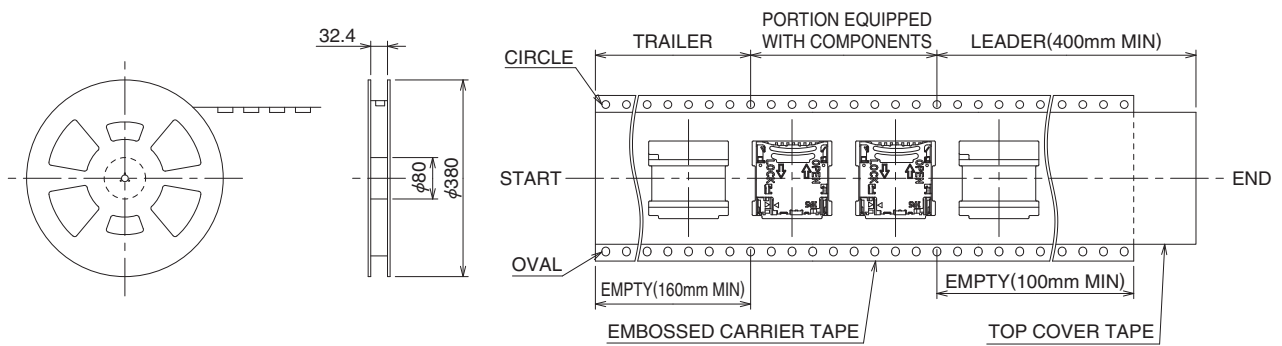

DM3D, Push-Pull (no ejection mechanism), Top board mounting (Standard)

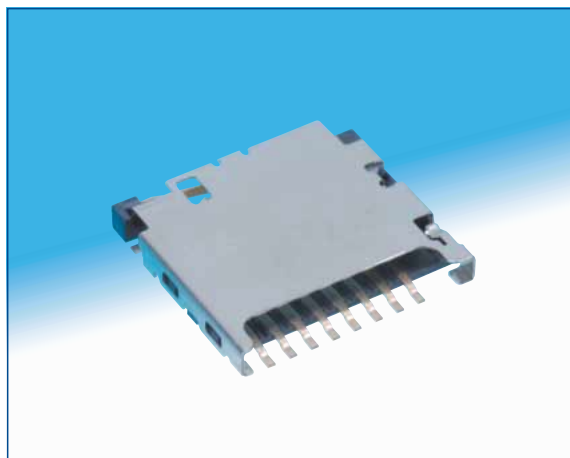

Part number	CL No.
DM3D-SF	609-0025-8

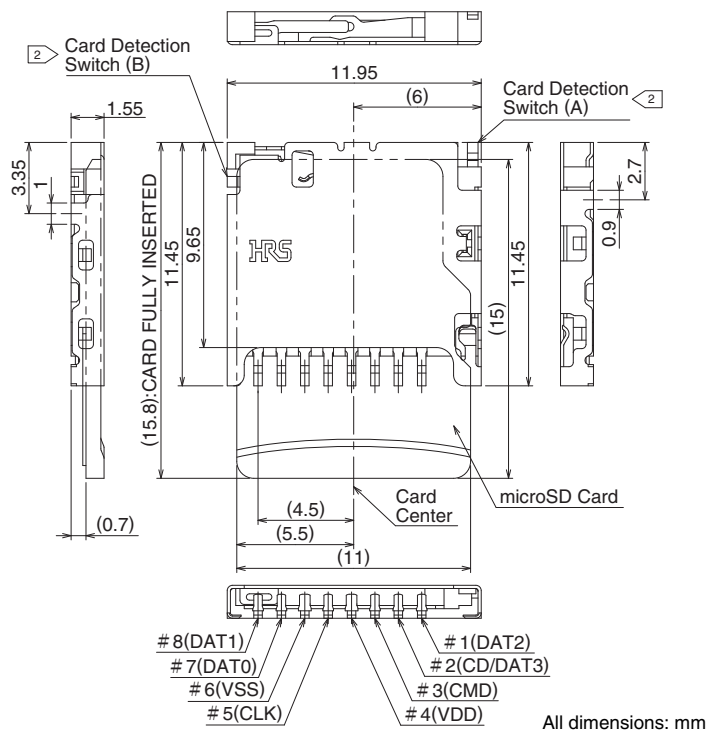

Recommended PCB mounting pattern

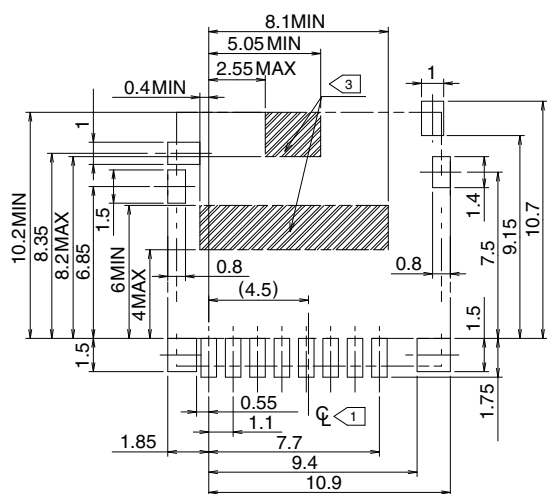

Note 1 ϕ indicates the center line of the microSD card slot.

Card detection switch			
Without the card		Card inserted	
Open		Closed	
(A)	(B)	(A)	(B)

Note 3 No conductive traces.

All dimensions: mm

Example of applications

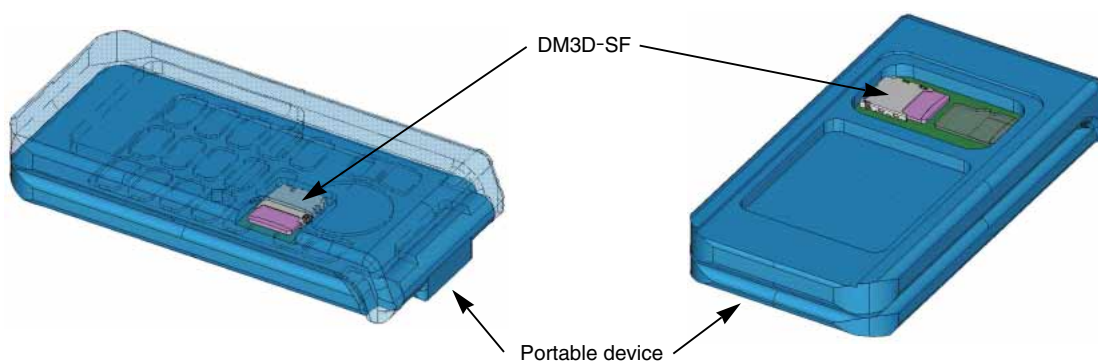

■Packaging Specifications

- Embossed carrier tape dimensions (2,000pieces per reel)

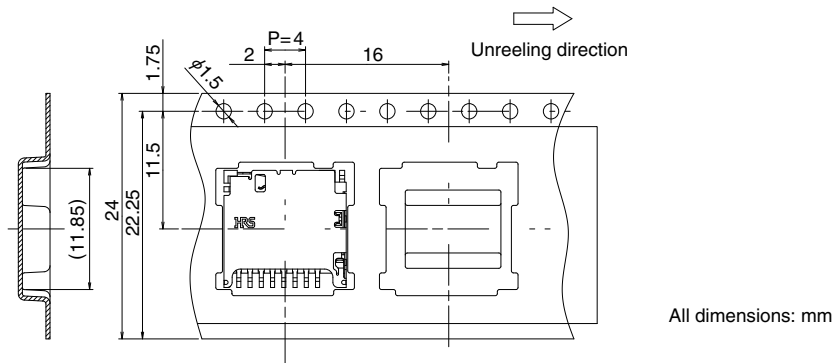

- Reel Dimensions

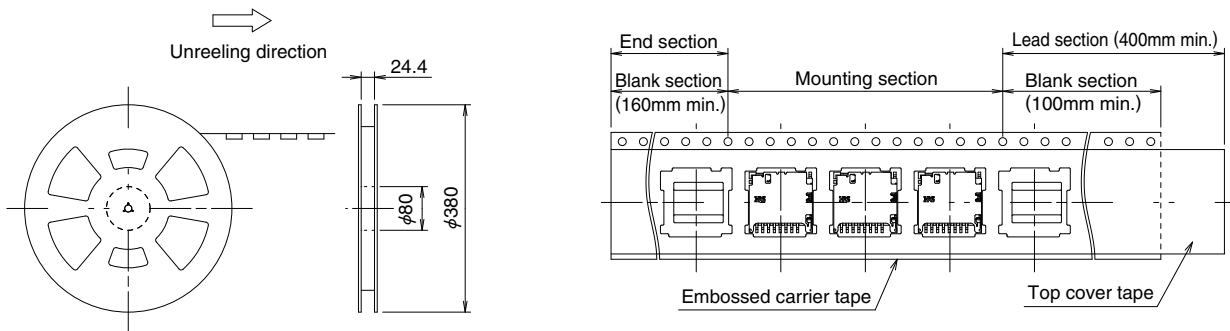

Recommended temperature profile

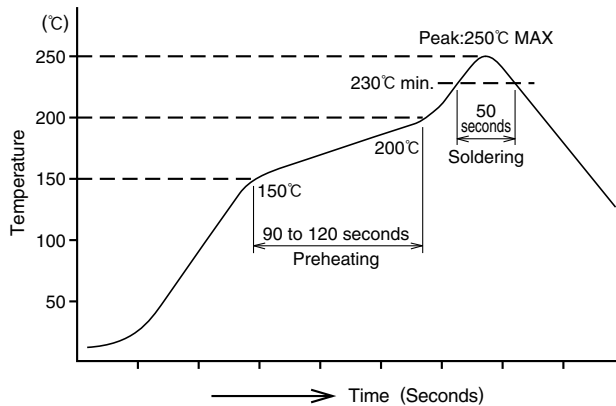

HRS test condition

Solder method :Reflow, IR/hot air

Environment :Room air

Solder composition :Paste, 96.5%Sn/3.0%Ag/0.5%Cu
(Senju Metal Industry, Co., Ltd.'s
Part Number:M705-GRN360-K2-V)

Test board :Glass epoxy 60mm×100mm×1.0mm thick

Metal mask :0.12mm thick

Number of reflow cycles : 2cycles max.

The temperature profiles shown are based on the above conditions.

In individual applications the actual temperature may vary, depending on solder paste type, volume / thickness and board size / thickness. Consult your solder paste and equipment manufacturer for specific recommendations.

Precautions

- Do not immerse or clean the entire connector with cleaning solutions as this may affect proper operation of the ejection mechanism and electrical performance of the connector
- Do not apply excessive force to the connector when handling or after installation on the PC board.
- The connectors will reliably connect and operate with the correctly inserted microSD™ cards. Follow the correct insertion / ejection procedure for the specific connector in use. Attempts of incorrect insertion of the card may cause damage to the connector or the card.
- The connector must be correctly mounted on the PC board before the card can be inserted. Do not insert the card in the un-mounted connector.
- Mounting on the Flexible Printed Circuit (FPC)
To assure correct performance it is recommended that a flat reinforcement plate 0.3 mm min. thick be used under the FPC.
- Small visible residual manufacturing fluids or tooling marks do not affect connector's performance.
- Repeated insertions and removal of the cards may leave some marks on the card itself. This will have no effect on the connector performance.

● Refer to applicable Operation Manual listed below for additional precautions.

Series	Operation Manual Number
DM3AT Series	ETAD-F0345
DM3BT Series	ETAD-F0324
DM3CS Series	ETAD-F0335
DM3D Series	ETAD-F0353

Компания «Life Electronics» занимается поставками электронных компонентов импортного и отечественного производства от производителей и со складов крупных дистрибьюторов Европы, Америки и Азии.

С конца 2013 года компания активно расширяет линейку поставок компонентов по направлению коаксиальный кабель, кварцевые генераторы и конденсаторы (керамические, пленочные, электролитические), за счёт заключения дистрибьюторских договоров

Мы предлагаем:

- Конкурентоспособные цены и скидки постоянным клиентам.
- Специальные условия для постоянных клиентов.
- Подбор аналогов.
- Поставку компонентов в любых объемах, удовлетворяющих вашим потребностям.
- Приемлемые сроки поставки, возможна ускоренная поставка.
- Доставку товара в любую точку России и стран СНГ.
- Комплексную поставку.
- Работу по проектам и поставку образцов.
- Формирование склада под заказчика.
- Сертификаты соответствия на поставляемую продукцию (по желанию клиента).
- Тестирование поставляемой продукции.
- Поставку компонентов, требующих военную и космическую приемку.
- Входной контроль качества.
- Наличие сертификата ISO.

В составе нашей компании организован Конструкторский отдел, призванный помогать разработчикам, и инженерам.

Конструкторский отдел помогает осуществить:

- Регистрацию проекта у производителя компонентов.
- Техническую поддержку проекта.
- Защиту от снятия компонента с производства.
- Оценку стоимости проекта по компонентам.
- Изготовление тестовой платы монтаж и пусконаладочные работы.



Тел: +7 (812) 336 43 04 (многоканальный)

Email: org@lifeelectronics.ru