



Main

Range of product	OsiSense XU
Series name	Application
Electronic sensor type	Photo-electric sensor
Sensor name	XUPK
Detection system	Diffuse Reflex
Emission	Infrared
[Sn] nominal sensing distance	0.33 ft (0.1 m) 0.6 m
Discrete output function	1 NO
Discrete output type	PNP
Electrical connection	2 female connector : RJ45
Material	PC (polycarbonate)

Complementary

Operating mode	Daisy chain
Product destination	XUPH
Topology	Manual teaching single chain with power supply XUPH : manual teaching daisy chain XUPH : PLC program daisy chain
Device application	Picking system
Maximum sensing distance	<= 0.15 m, diffuse infrared with dynamic threshold <= 0.6 m, reflex infrared with reflector
Hysteresis	<= 15 %
Output type	Solid state PNP (NO)
[Us] rated supply voltage	12...24 V
Discrete input voltage	12...24 V
Maximum output current	100 mA
Voltage drop	<= 2 V at output
Current consumption	<= 50 mA, no-load
Delay response	200 ms
Delay recovery	200 ms
Number of connected devices	14 daisy chain 64
Status LED	2 LED green parts to be taken 1 LED red wrong taken
Switching capacity in mA	100 mA
Setting-up	Without sensitivity adjustment
Overvoltage category	II
Fixing mode	By clamp By screws
Depth	1.3 in (33 mm)
Height	1.57 in (40 mm)
Length	3.62 in (92 mm)
Product weight	0.08 lb(US) (0.035 kg)

Environment

product certifications	CE
ambient air temperature for operation	14...140 °F (-10...60 °C)
environmental characteristic	EMC conforming to EN 60947-5-2

The information provided in this documentation contains general descriptions and/or technical characteristics of the performance of the products contained herein. This documentation is not intended as a substitute for and is not to be used for determining suitability or reliability of these products for specific user applications. It is the duty of any such user or integrator to perform the appropriate and complete risk analysis, evaluation and testing of the products with respect to the relevant specific application or use thereof. Neither Schneider Electric Industries SAS nor any of its affiliates or subsidiaries shall be responsible or liable for misuse of the information contained herein.

Offer Sustainability

Not Green Premium product

Not Green Premium product

WARNING: This product can expose you to chemicals including:

WARNING: This product can expose you to chemicals including:

Diisononyl phthalate (DINP), which is known to the State of California to cause cancer, and

Diisononyl phthalate (DINP), which is known to the State of California to cause cancer, and

Di-isodecyl phthalate (DIDP), which is known to the State of California to cause birth defects or other reproductive harm.

Di-isodecyl phthalate (DIDP), which is known to the State of California to cause birth defects or other reproductive harm.

For more information go to www.p65warnings.ca.gov

For more information go to www.p65warnings.ca.gov

Dimensions

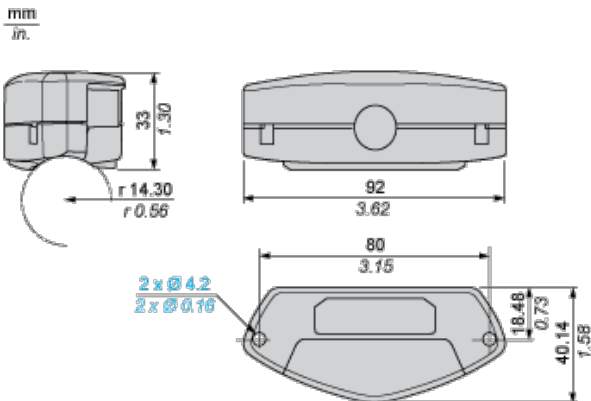

Control by a PC or PLC through the XUPH Ethernet Modbus TCP - IP Communication Box

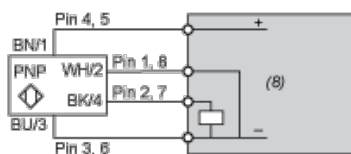
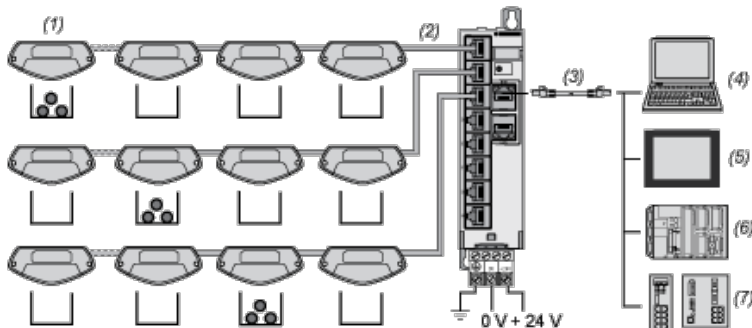

(1) Daisy chain of Picking Sensors XUPK2 on the Ethernet Modbus TCP-IP communication box XUPH001

Daisy Chain

- maximum chain of Picking Sensors in a line = 14 (in the example = 4 Picking Sensors)
- maximum number of lines : 8 (in the example = 3 lines)
- maximum number of Picking Sensors on XUPH Communication box : = 64 (in the example = 12 Picking Sensors)

(2) Cable RJ45/RJ45, straight.

(3) Ethernet Cable RJ45/RJ45, straight.

(4) PC: Personal Computer.

(5) HMI: Human Machine Interface.

(6) PLC: Programmable Logic Controller.

(7) Ethernet hub or switch.

(8) Communication box

Detection Curves

Detection in a 10 mm/0.39 in. Tubular Beam

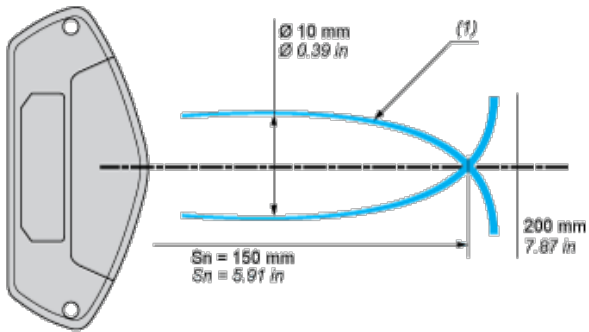

(1) Detection zone

S_n : Sensing distance

Mounting

Mounting on a Flat Panel (Fixation Holes M4)

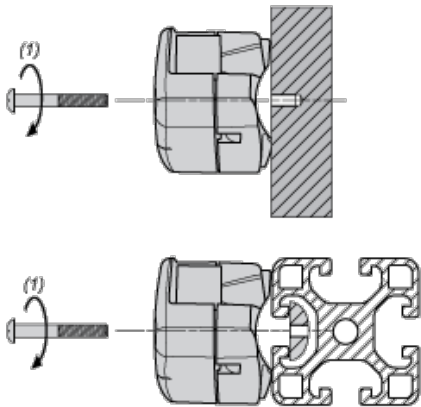

(1) Maximum tightening torque: 0,8 Nm / 7.08 lb-in.

Mounting on Tubes (with Plastic Clamps)

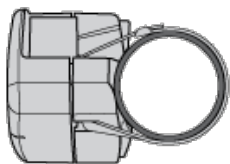

Компания «Life Electronics» занимается поставками электронных компонентов импортного и отечественного производства от производителей и со складов крупных дистрибьюторов Европы, Америки и Азии.

С конца 2013 года компания активно расширяет линейку поставок компонентов по направлению коаксиальный кабель, кварцевые генераторы и конденсаторы (керамические, пленочные, электролитические), за счёт заключения дистрибьюторских договоров

Мы предлагаем:

- Конкурентоспособные цены и скидки постоянным клиентам.
- Специальные условия для постоянных клиентов.
- Подбор аналогов.
- Поставку компонентов в любых объемах, удовлетворяющих вашим потребностям.
- Приемлемые сроки поставки, возможна ускоренная поставка.
- Доставку товара в любую точку России и стран СНГ.
- Комплексную поставку.
- Работу по проектам и поставку образцов.
- Формирование склада под заказчика.
- Сертификаты соответствия на поставляемую продукцию (по желанию клиента).
- Тестирование поставляемой продукции.
- Поставку компонентов, требующих военную и космическую приемку.
- Входной контроль качества.
- Наличие сертификата ISO.

В составе нашей компании организован Конструкторский отдел, призванный помогать разработчикам, и инженерам.

Конструкторский отдел помогает осуществить:

- Регистрацию проекта у производителя компонентов.
- Техническую поддержку проекта.
- Защиту от снятия компонента с производства.
- Оценку стоимости проекта по компонентам.
- Изготовление тестовой платы монтаж и пусконаладочные работы.



Тел: +7 (812) 336 43 04 (многоканальный)

Email: org@lifeelectronics.ru