

MAX4715/MAX4716

0.4Ω, Low-Voltage, Single-Supply SPST Analog Switches in SC70

General Description

The MAX4715/MAX4716 are low on-resistance, low-voltage, single-pole/single-throw (SPST) analog switches that operate from a +1.6V to +3.6V single supply. The MAX4715 is normally open (NO), and the MAX4716 is normally closed (NC). These devices also have fast switching speeds ($t_{ON} = 18\text{ns}$ max, $t_{OFF} = 12\text{ns}$ max).

When powered from a +3V supply, the MAX4715/MAX4716 offer 0.4Ω max on-resistance (R_{ON}) with 0.1Ω max R_{ON} flatness. Their digital logic inputs are +1.8V CMOS compatible when using a single +3V supply.

The MAX4715 is pin compatible with the MAX4594, and the MAX4716 is pin compatible with the MAX4595. The MAX4715/MAX4716 are available in SC70-5 packages.

Applications

- Power Routing
- Battery-Operated Equipment
- Audio and Video Signal Routing
- Low-Voltage Data-Acquisition Systems
- Communications Circuits
- PCMCIA Cards
- Cellular Phones
- Modems
- Hard Drives

Benefits and Features

- Low R_{ON}
 - 0.4Ω max (+3V Supply)
 - 1.2Ω max (+1.8V Supply)
- 0.1Ω max R_{ON} Flatness (+3V Supply)
- +1.6V to +3.6V Single-Supply Operation
- Available in 5-Pin SC70 Packages
- Fast Switching: $t_{ON} = 18\text{ns}$ max, $t_{OFF} = 12\text{ns}$ max
- +1.8V CMOS Logic Compatible (+3V Supply)
- Pin Compatible with MAX4594 (MAX4715)
Pin Compatible with MAX4595 (MAX4716)

[Ordering Information](#) appears at end of data sheet.

Absolute Maximum Ratings

Voltages Referenced to GND

V+, IN-0.3V to +4V
 COM, NO, NC (Note 1)-0.3V to (V+ + 0.3V)
 Continuous Current NO, NC to COM±300mA
 Peak Switch Current NO, NC to COM
 (pulsed at 1ms, 10% duty cycle max)±600mA
 Continuous Power Dissipation (T_A = +70°C)
 5-Pin SC70 (derate 3.1mW/°C above +70°C).....247mW

Operating Temperature Range

MAX471_EXK..... -40°C to +85°C
 Junction Temperature +150°C
 Storage Temperature Range -65°C to +150°C
 Lead Temperature (soldering, 10s) +300°C

Note 1: Signals on NO, NC, or COM exceeding V+ or GND are clamped by internal diodes.

Stresses beyond those listed under "Absolute Maximum Ratings" may cause permanent damage to the device. These are stress ratings only, and functional operation of the device at these or any other conditions beyond those indicated in the operational sections of the specifications is not implied. Exposure to absolute maximum rating conditions for extended periods may affect device reliability.

Package Information

5-PIN SC70

Outline Number	21-0076
----------------	-------------------------

For the latest package outline information and land patterns (footprints), go to www.maximintegrated.com/packages. Note that a "+", "#", or "-" in the package code indicates RoHS status only. Package drawings may show a different suffix character, but the drawing pertains to the package regardless of RoHS status.

Electrical Characteristics—Single +3V Supply

(V+ = +2.7V to +3.6V, V_{IH} = +1.4V, V_{IL} = +0.5V, T_A = T_{MIN} to T_{MAX}, unless otherwise noted. Typical values are at V+ = +3.0V and T_A = +25°C.) (Notes 2, 3)

PARAMETER	SYMBOL	CONDITIONS	T _A	MIN	TYP	MAX	UNITS
ANALOG SWITCH							
Analog Signal Range	V _{COM} , V _{NO} , V _{NC}			0		V+	V
On-Resistance (Note 6)	R _{ON}	V+ = 2.7V, I _{COM} = 100mA, V _{NO} or V _{NC} = 1.5V	+25°C		0.3	0.4	Ω
			T _{MIN} to T _{MAX}			0.45	
On-Resistance Flatness (Note 4)	R _{FLAT(ON)}	V+ = 2.7V, I _{COM} = 100mA, V _{NO} or V _{NC} = 0.6, 1.5V, 2.1V	+25°C		0.05	0.09	Ω
			T _{MIN} to T _{MAX}			0.1	
NO, NC Off-Leakage Current	I _{NO(OFF)} or I _{NC(OFF)} or	V+ = 3.3V, V _{COM} = 0.3V, 3V V _{NO} or V _{NC} = 3V, 0.3V	+25°C	-1	0.01	1	nA
			T _{MIN} to T _{MAX}			10	
COM Off-Leakage Current	I _{COM(OFF)}	V+ = 3.3V, V _{COM} = 0.3V, 3V V _{NO} or V _{NC} = 3V, 0.3V	+25°C	-1	0.01	1	nA
			T _{MIN} to T _{MAX}			10	
COM On-Leakage Current	I _{COM(ON)}	V+ = 3.3V, V _{COM} = 0.3V, 3V, V _{NO} or V _{NC} = 0.3V, 3V or open	+25°C	-2		2	nA
			T _{MIN} to T _{MAX}			10	
DYNAMIC							
Turn-On Time	t _{ON}	V _{NO} or V _{NC} = 1.5V, R _L = 50Ω, C _L = 35pF, Figure 1	+25°C		12	18	ns
			T _{MIN} to T _{MAX}			20	
Turn-Off Time	t _{OFF}	V _{NO} or V _{NC} = 1.5V, R _L = 50Ω, C _L = 35pF, Figure 1	+25°C		6	12	ns
			T _{MIN} to T _{MAX}			15	
Charge Injection	Q	V _{GEN} = 0, R _{GEN} = 0, C _L = 1.0nF, Figure 2	+25°C		20		pC
Off-Isolation (Note 5)	V _{ISO}	f = 1MHz, V _{COM} = 1V _{RMS} , R _L = 50Ω, C _L = 5pF, Figure 3	+25°C		-54		dB
Total Harmonic Distortion	THD	f = 20Hz to 20kHz, V _{COM} = 2V _{P-P} , R _L = 32Ω	+25°C		0.01		%
NC or NO Off-Capacitance	C _{NO(OFF)} C _{NC(OFF)}	f = 1MHz, Figure 4	+25°C		55		pF
COM Off-Capacitance	C _{COM(OFF)}	f = 1MHz, Figure 4	+25°C		55		pF
COM On-Capacitance	C _{COM(ON)}	f = 1MHz, Figure 4	+25°C		80		pF
LOGIC INPUT							
Input Voltage Low	V _{IL}					0.5	V
Input Voltage High	V _{IH}			1.4			V
Input Leakage Current	I _{IN}	V _{IN} = 0 or V+		-1		1	μA
SUPPLY							
Power-Supply Range	V+			1.6		3.6	V
Positive Supply Current	I+	V+ = +3.6V, V _{IN} = 0 or V+	+25°C		0.04	0.2	μA
			T _{MIN} to T _{MAX}			2	

Electrical Characteristics—Single +1.8V Supply

(V+ = +1.8V, V_{IH} = +1V, V_{IL} = +0.4V, T_A = T_{MIN} to T_{MAX}, unless otherwise noted. Typical values are at T_A = +25°C.) (Notes 2, 3)

PARAMETER	SYMBOL	CONDITIONS	T _A	MIN	TYP	MAX	UNITS
ANALOG SWITCH							
Analog Signal Range	V _{COM} , V _{NO} , V _{NC}			0		V+	V
On-Resistance	R _{ON}	I _{COM} = 10mA, V _{NO} or V _{NC} = 0.9V	+25°C		0.6	1.2	Ω
			T _{MIN} to T _{MAX}			2.5	
NO or NC Off-Leakage Current	I _{NO(OFF)} or I _{NC(OFF)}	V _{COM} = 0.3V, 1.5V, V _{NO} or V _{NC} = 1.5V, 0.3V	+25°C	-1		1	nA
			T _{MIN} to T _{MAX}		-10		
COM Off-Leakage Current	I _{COM(OFF)}	V _{COM} = 0.3V, 1.5V, V _{NO} or V _{NC} = 1.5V, 0.3V	+25°C	-1		1	nA
			T _{MIN} to T _{MAX}		-10		
COM On-Leakage Current	I _{COM(ON)}	V _{COM} = 1.5V, 0.3V, V _{NO} or V _{NC} = 1.5V, 0.3V, or open	+25°C	-2		2	nA
			T _{MIN} to T _{MAX}		-10		
DYNAMIC							
Turn-On Time	t _{ON}	V _{NO} or V _{NC} = 1.5V, R _L = 50Ω, C _L = 35pF, Figure 1	+25°C		18	25	ns
			T _{MIN} to T _{MAX}			30	
Turn-Off Time	t _{OFF}	V _{NO} or V _{NC} = 1.5V, R _L = 50Ω, C _L = 35pF, Figure 1	+25°C		9	20	ns
			T _{MIN} to T _{MAX}			25	
Charge Injection	Q	V _{GEN} = 0, R _{GEN} = 0, C _L = 1nF, Figure 2	+25°C		40		pC
LOGIC INPUT							
Input Voltage Low	V _{IL}					0.4	V
Input Voltage High	V _{IH}			1			V
Input Leakage Current	I _{IN}	V _{IN} = 0 or V+				1	μA
SUPPLY							
Positive Supply Current	I+	V _{IN} = 0 or V+	+25°C		0.04	0.2	μA
			T _{MIN} to T _{MAX}			2	

Note 2: The algebraic convention, where the most negative value is a minimum and the most positive value a maximum, is used in this data sheet.

Note 3: SC70-packaged parts are 100% tested at +25°C. Limits across the full temperature range are guaranteed by design and correlation.

Note 4: Flatness is defined as the difference between the maximum and minimum values of on-resistance as measured over the specified analog signal range.

Note 5: Off-Isolation = 20log₁₀ [V_{COM} / (V_{NC} or V_{NO})], V_{COM} = output, V_{NC} or V_{NO} = input to off switch.

Note 6: Guaranteed by design.

Typical Operating Characteristics

($T_A = +25^\circ\text{C}$, unless otherwise noted.)

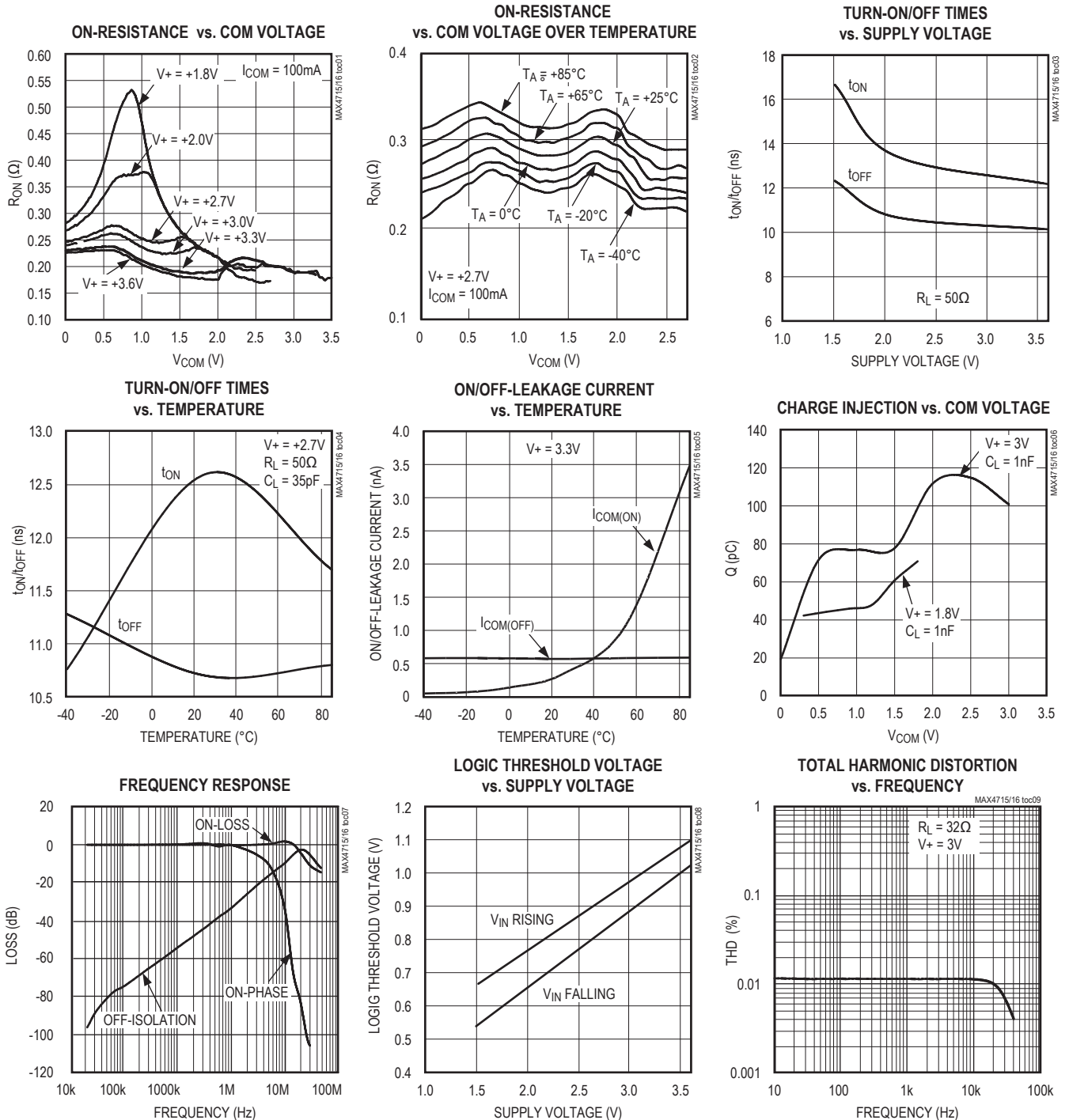

Pin Configurations/Functional Diagrams/Truth Tables

TOP VIEW

MAX4715

SC70-5

MAX4715	
LOGIC	SWITCH
0	OFF
1	ON

MAX4716

SC70-5

MAX4716	
LOGIC	SWITCH
0	ON
1	OFF

SWITCHES SHOWN FOR LOGIC "0" INPUT.

Pin Description

BUMP		NAME	FUNCTION
MAX4715	MAX4716		
1	1	COM	Analog Switch—Common
2	—	NO	Analog Switch—Normally Open
3	2	NC	Analog Switch—Normally Closed
—	3	GND	Ground
4	4	IN	Digital Control Input
5	5	V+	Positive Supply Input

MAX4715/MAX4716

0.4Ω, Low-Voltage, Single-Supply SPST Analog Switches in SC70

Detailed Description

The MAX4715/MAX4716 are low on-resistance (R_{ON}), low-voltage, single-pole/single-throw (SPST) analog switches that operate from a +1.6V to +3.6V single supply. The MAX4715 is normally open (NO), and the MAX4716 is normally closed (NC).

When powered from a +3V supply, their 0.4Ω R_{ON} allows high continuous currents to be switched in a variety of applications.

Applications Information

Logic Inputs

The MAX4715/MAX4716 logic inputs can be driven up to +3.6V regardless of the supply voltage. For example,

with a +3.3V supply, IN may be driven low to GND and high to +3.6V. Driving IN Rail-to-Rail® minimizes power consumption.

Analog Signal Levels

Analog signals that range over the entire supply voltage ($V+$ to GND) can be passed with very little change in on-resistance (see the [Typical Operating Characteristics](#) section). The switches are bidirectional, so the NO, NC, and COM pins can be used as either inputs or outputs.

Rail-to-Rail is a registered trademark of Nippon Motorola Ltd.

Test Circuits/Timing Diagrams

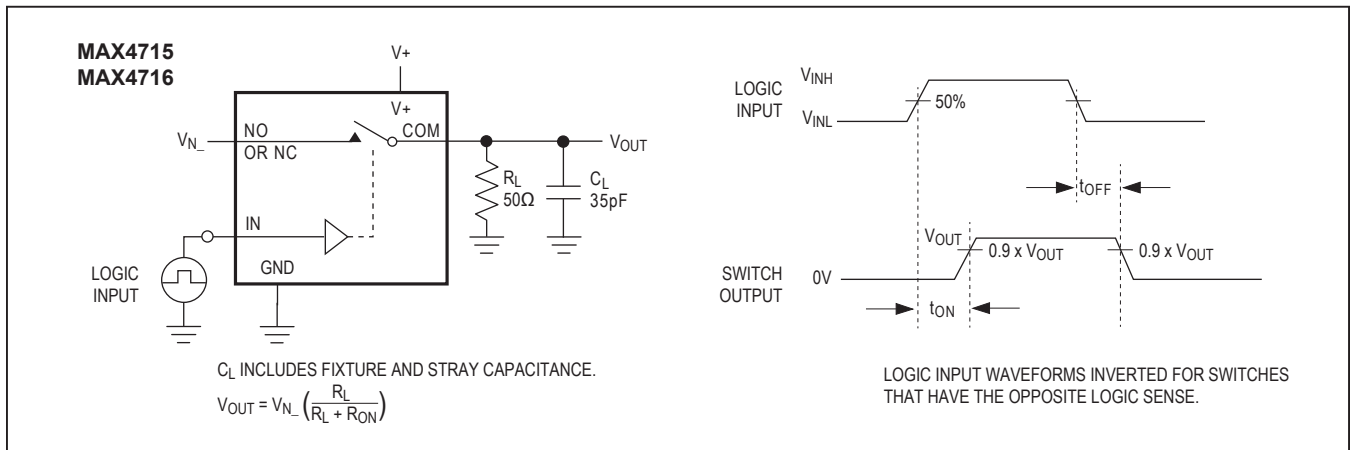

Figure 1. Switching Time

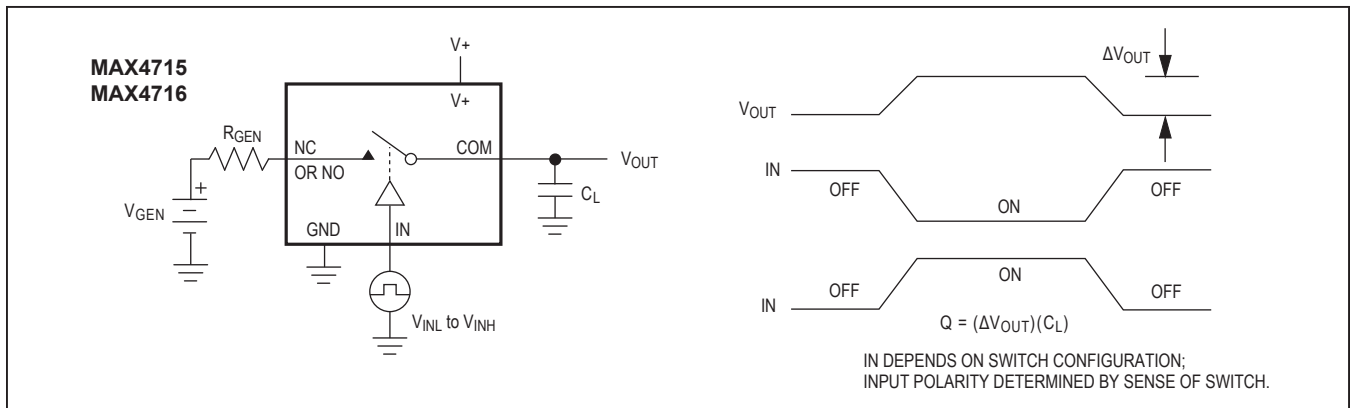

Figure 2. Charge Injection

Test Circuits/Timing Diagrams (continued)

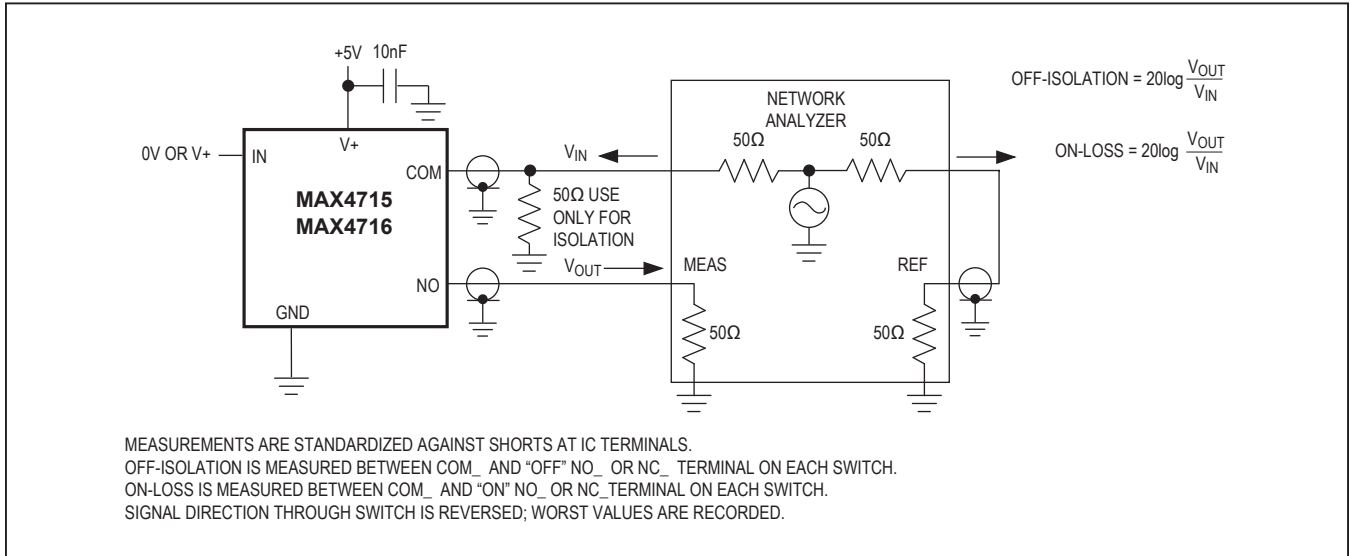

Figure 3. On-Loss and Off-Isolation

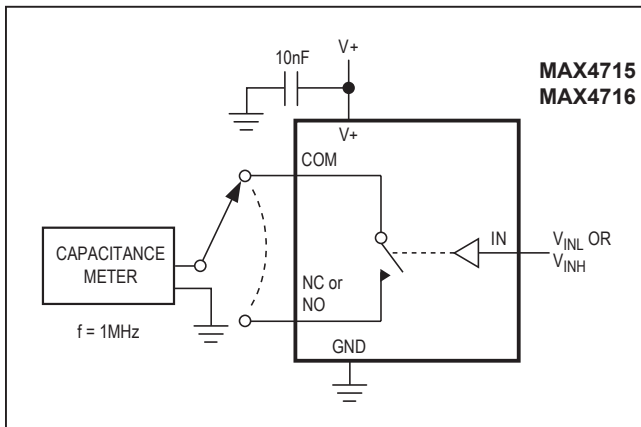

Figure 4. Channel Off/On-Capacitance

Ordering Information

PART	TEMP. RANGE	PIN-PACKAGE	TOP MARK
MAX4715EXK+T	-40°C to +85°C	5 SC70-5	ACJ
MAX4716EXK+T	-40°C to +85°C	5 SC70-5	ACK

+ Denotes a lead(Pb)-free/RoHS-compliant package.
 T = Tape and reel.

Chip Information

TRANSISTOR COUNT: 135
 PROCESS: CMOS

Revision History

REVISION NUMBER	REVISION DATE	DESCRIPTION	PAGES CHANGED
0	4/01	Initial release	—
1	3/20	Updated the <i>Ordering Information</i> table	8

For pricing, delivery, and ordering information, please visit Maxim Integrated's online storefront at <https://www.maximintegrated.com/en/storefront/storefront.html>.

Maxim Integrated cannot assume responsibility for use of any circuitry other than circuitry entirely embodied in a Maxim Integrated product. No circuit patent licenses are implied. Maxim Integrated reserves the right to change the circuitry and specifications without notice at any time. The parametric values (min and max limits) shown in the Electrical Characteristics table are guaranteed. Other parametric values quoted in this data sheet are provided for guidance.

Компания «Life Electronics» занимается поставками электронных компонентов импортного и отечественного производства от производителей и со складов крупных дистрибьюторов Европы, Америки и Азии.

С конца 2013 года компания активно расширяет линейку поставок компонентов по направлению коаксиальный кабель, кварцевые генераторы и конденсаторы (керамические, пленочные, электролитические), за счёт заключения дистрибьюторских договоров

Мы предлагаем:

- Конкурентоспособные цены и скидки постоянным клиентам.
- Специальные условия для постоянных клиентов.
- Подбор аналогов.
- Поставку компонентов в любых объемах, удовлетворяющих вашим потребностям.
- Приемлемые сроки поставки, возможна ускоренная поставка.
- Доставку товара в любую точку России и стран СНГ.
- Комплексную поставку.
- Работу по проектам и поставку образцов.
- Формирование склада под заказчика.
- Сертификаты соответствия на поставляемую продукцию (по желанию клиента).
- Тестирование поставляемой продукции.
- Поставку компонентов, требующих военную и космическую приемку.
- Входной контроль качества.
- Наличие сертификата ISO.

В составе нашей компании организован Конструкторский отдел, призванный помогать разработчикам, и инженерам.

Конструкторский отдел помогает осуществить:

- Регистрацию проекта у производителя компонентов.
- Техническую поддержку проекта.
- Защиту от снятия компонента с производства.
- Оценку стоимости проекта по компонентам.
- Изготовление тестовой платы монтаж и пусконаладочные работы.



Тел: +7 (812) 336 43 04 (многоканальный)
Email: org@lifeelectronics.ru