



**MICROCHIP**

---

**Voltage Supervisor SOT-23-5/6  
Evaluation Board  
User's Guide**

---

**Note the following details of the code protection feature on Microchip devices:**

- Microchip products meet the specification contained in their particular Microchip Data Sheet.
- Microchip believes that its family of products is one of the most secure families of its kind on the market today, when used in the intended manner and under normal conditions.
- There are dishonest and possibly illegal methods used to breach the code protection feature. All of these methods, to our knowledge, require using the Microchip products in a manner outside the operating specifications contained in Microchip's Data Sheets. Most likely, the person doing so is engaged in theft of intellectual property.
- Microchip is willing to work with the customer who is concerned about the integrity of their code.
- Neither Microchip nor any other semiconductor manufacturer can guarantee the security of their code. Code protection does not mean that we are guaranteeing the product as "unbreakable."

Code protection is constantly evolving. We at Microchip are committed to continuously improving the code protection features of our products. Attempts to break Microchip's code protection feature may be a violation of the Digital Millennium Copyright Act. If such acts allow unauthorized access to your software or other copyrighted work, you may have a right to sue for relief under that Act.

---

Information contained in this publication regarding device applications and the like is provided only for your convenience and may be superseded by updates. It is your responsibility to ensure that your application meets with your specifications. MICROCHIP MAKES NO REPRESENTATIONS OR WARRANTIES OF ANY KIND WHETHER EXPRESS OR IMPLIED, WRITTEN OR ORAL, STATUTORY OR OTHERWISE, RELATED TO THE INFORMATION, INCLUDING BUT NOT LIMITED TO ITS CONDITION, QUALITY, PERFORMANCE, MERCHANTABILITY OR FITNESS FOR PURPOSE. Microchip disclaims all liability arising from this information and its use. Use of Microchip devices in life support and/or safety applications is entirely at the buyer's risk, and the buyer agrees to defend, indemnify and hold harmless Microchip from any and all damages, claims, suits, or expenses resulting from such use. No licenses are conveyed, implicitly or otherwise, under any Microchip intellectual property rights.

**Trademarks**

The Microchip name and logo, the Microchip logo, Accuron, dsPIC, KEELOQ, microID, MPLAB, PIC, PICmicro, PICSTART, PRO MATE, PowerSmart, rfPIC and SmartShunt are registered trademarks of Microchip Technology Incorporated in the U.S.A. and other countries.

AmpLab, FilterLab, Migratable Memory, MXDEV, MXLAB, SEEVAL, SmartSensor and The Embedded Control Solutions Company are registered trademarks of Microchip Technology Incorporated in the U.S.A.

Analog-for-the-Digital Age, Application Maestro, dsPICDEM, dsPICDEM.net, dsPICworks, ECAN, ECONOMONITOR, FanSense, FlexROM, fuzzyLAB, In-Circuit Serial Programming, ICSP, ICEPIC, Linear Active Thermistor, Mindi, MiWi, MPASM, MPLIB, MPLINK, PICKit, PICDEM, PICDEM.net, PICLAB, PICTail, PowerCal, PowerInfo, PowerMate, PowerTool, REAL ICE, rLAB, rfPICDEM, Select Mode, Smart Serial, SmartTel, Total Endurance, UNI/O, WiperLock and ZENA are trademarks of Microchip Technology Incorporated in the U.S.A. and other countries.

SQTP is a service mark of Microchip Technology Incorporated in the U.S.A.

All other trademarks mentioned herein are property of their respective companies.

© 2006, Microchip Technology Incorporated, Printed in the U.S.A., All Rights Reserved.

 Printed on recycled paper.

**QUALITY MANAGEMENT SYSTEM  
CERTIFIED BY DNV  
== ISO/TS 16949:2002 ==**

*Microchip received ISO/TS-16949:2002 certification for its worldwide headquarters, design and wafer fabrication facilities in Chandler and Tempe, Arizona, Gresham, Oregon and Mountain View, California. The Company's quality system processes and procedures are for its PICmicro® 8-bit MCUs, KEELOQ® code hopping devices, Serial EEPROMs, microperipherals, nonvolatile memory and analog products. In addition, Microchip's quality system for the design and manufacture of development systems is ISO 9001:2000 certified.*



# VOLTAGE SUPERVISOR SOT-23-5/6 EVALUATION BOARD USER'S GUIDE

---

---

## Table of Contents

---

---

<b>Preface</b> .....	<b>1</b>
<b>Chapter 1. Product Overview</b> .....	<b>5</b>
1.1 Introduction .....	5
1.2 What is the Voltage Supervisor SOT-23-5/6 Evaluation Board? .....	5
1.3 What the Voltage Supervisor SOT-23-5/6 Evaluation Board Kit Includes .....	5
<b>Chapter 2. Installation and Operation</b> .....	<b>7</b>
2.1 Introduction .....	7
2.2 Features .....	7
2.3 Getting Started .....	8
2.4 Voltage Supervisor SOT-23-5/6 Evaluation Board Description .....	16
2.5 Voltage Supervisor/Voltage Detector Circuits .....	19
2.6 Digital Potentiometer Circuit .....	23
<b>Appendix A. Schematics and Layouts</b> .....	<b>25</b>
A.1 Introduction .....	25
A.2 Schematics and PCB Layout .....	25
A.3 Schematic .....	26
A.4 Board Layout – Top Layer, Bottom Layer and Silk Screen .....	27
A.5 Board Layout – Top Layer and Silk Screen .....	28
A.6 Board Layout – Bottom Layer .....	29
A.7 Board Layout – Ground Plane .....	30
A.8 Board Layout – Power Layer .....	31
A.9 Board Layout – Top Components and Silk Screen .....	32
<b>Appendix B. Bill Of Materials (BOM)</b> .....	<b>33</b>
<b>Appendix C. Microchip SOT-23-5/6 Device Compatibility</b> .....	<b>35</b>
C.1 Introduction .....	35
C.2 PCB Compatibility .....	35
C.3 Ideas on Evaluating An LDO .....	39
<b>Worldwide Sales and Service</b> .....	<b>40</b>

# Voltage Supervisor SOT-23-5/6 Evaluation Board User's Guide

---

NOTES:



# VOLTAGE SUPERVISOR SOT-23-5/6 EVALUATION BOARD USER'S GUIDE

## Preface

### NOTICE TO CUSTOMERS

All documentation becomes dated, and this manual is no exception. Microchip tools and documentation are constantly evolving to meet customer needs, so some actual dialogs and/or tool descriptions may differ from those in this document. Please refer to our web site ([www.microchip.com](http://www.microchip.com)) to obtain the latest documentation available.

Documents are identified with a "DS" number. This number is located on the bottom of each page, in front of the page number. The numbering convention for the DS number is "DSXXXXA", where "XXXX" is the document number and "A" is the revision level of the document.

For the most up-to-date information on development tools, see the MPLAB® IDE on-line help. Select the Help menu, and then Topics to open a list of available on-line help files.

## INTRODUCTION

This chapter contains general information that will be useful to know before using the Voltage Supervisor SOT-23-5/6 Evaluation Board. Items discussed in this chapter include:

- Document Layout
- Conventions Used in this Guide
- Recommended Reading
- The Microchip Web Site
- Customer Support
- Document Revision History

## DOCUMENT LAYOUT

This document describes how to use the Voltage Supervisor SOT-23-5/6 Evaluation Board. The manual layout is as follows:

- **Chapter 1. "Product Overview"** – Important information about the Voltage Supervisor SOT-23-5/6 Evaluation Board.
- **Chapter 2. "Installation and Operation"** – Includes instructions on how to get started with the Voltage Supervisor SOT-23-5/6 Evaluation Board.
- **Appendix A. "Schematics and Layouts"** – Shows the schematic and layout diagrams for the Voltage Supervisor SOT-23-5/6 Evaluation Board.
- **Appendix B. "Bill Of Materials (BOM)"** – Lists the parts used to build the Voltage Supervisor SOT-23-5/6 Evaluation Board.
- **Appendix C. "Microchip SOT-23-5/6 Device Compatibility"** – Explains how this board may be used with other Microchip analog devices in the SOT-23-5 or SOT-23-6 packages.

# Voltage Supervisor SOT-23-5/6 Evaluation Board User's Guide

## CONVENTIONS USED IN THIS GUIDE

This manual uses the following documentation conventions:

### DOCUMENTATION CONVENTIONS

Description	Represents	Examples
<b>Arial font:</b>		
Italic characters	Referenced books	<i>MPLAB<sup>®</sup> IDE User's Guide</i>
	Emphasized text	...is the <i>only</i> compiler...

## RECOMMENDED READING

Table 1-1 shows the device and associated data sheet literature number. These documents can be downloaded from the Microchip web site at: [www.microchip.com](http://www.microchip.com).

**TABLE 1-1: DEVICES AND DATA SHEET LITERATURE NUMBERS**

Device	Literature #	Device	Literature #	Device	Literature #
<b>MCP601</b>	21314	<b>MCP6541</b>	21690	<b>TC52</b>	21430
<b>MCP601R</b>	21314	<b>MCP6541R</b>	21690	<b>TC53</b>	21432
<b>MCP606</b>	11177	<b>MCP6546</b>	21714	<b>TC54</b>	21434
<b>MCP6001</b>	21733	<b>MCP6546R</b>	21714	<b>TC105</b>	21349
<b>MCP6001R</b>	21733	<b>MCP3221</b>	21732	<b>TC77</b>	20092
<b>MCP6001U</b>	21733	<b>MCP9800</b>	21909	<b>MCP603</b>	21314
<b>MCP6231</b>	21881	<b>MCP9802</b>	21909	<b>TC1035</b>	21343
<b>MCP6231R</b>	21881	<b>MCP4012</b>	21978	<b>MCP4022</b>	21916
<b>MCP6231U</b>	21881	<b>MCP4013</b>	21978	<b>MCP4023</b>	21916
<b>MCP6241</b>	21882	<b>MCP4014</b>	21978	<b>MCP4024</b>	21916
<b>MCP6241R</b>	21882	<b>TC1014</b>	21335	<b>MCP73826</b>	21705
<b>MCP6241U</b>	21882	<b>TC1015</b>	21335	<b>PIC10F200</b>	41239
<b>MCP1316</b>	21985	<b>TC1017</b>	21813	<b>PIC10F202</b>	41239
<b>MCP1317</b>	21985	<b>TC1054</b>	21350	<b>PIC10F204</b>	41239
<b>MCP1318</b>	21985	<b>TC1055</b>	21350	<b>PIC10F206</b>	41239
<b>MCP1319</b>	21985	<b>TC1070</b>	21353	<b>TC1185</b>	21350
<b>MCP1320</b>	21985	<b>TC1071</b>	21353	<b>TC1186</b>	21353
<b>MCP1321</b>	21985	<b>TC1034</b>	21343	<b>TC1187</b>	21368
<b>MCP1322</b>	21985	<b>TC1037</b>	21344	<b>TC1223</b>	21368
<b>TC2014</b>	21662	<b>TC1038</b>	21344	<b>TC1224</b>	21368
<b>TC2015</b>	21662	<b>TC1039</b>	21344	<b>TC2055</b>	21663
<b>TC2185</b>	21662	<b>TC2054</b>	21663	<b>TC2186</b>	21663

## THE MICROCHIP WEB SITE

Microchip provides online support via our web site at [www.microchip.com](http://www.microchip.com). This web site is used as a means to make files and information easily available to customers. Accessible by using your favorite internet browser, the web site contains the following information:

- **Product Support** – Data sheets and errata, application notes and sample programs, design resources, user's guides and hardware support documents, latest software releases and archived software
- **General Technical Support** – Frequently Asked Questions (FAQs), technical support requests, online discussion groups, Microchip consultant program member listing
- **Business of Microchip** – Product selector and ordering guides, latest Microchip press releases, listing of seminars and events, listings of Microchip sales offices, distributors and factory representatives

## CUSTOMER SUPPORT

Users of Microchip products can receive assistance through several channels:

- Distributor or Representative
- Local Sales Office
- Field Application Engineer (FAE)
- Technical Support
- Development Systems Information Line

Customers should contact their distributor, representative or field application engineer for support. Local sales offices are also available to help customers. A listing of sales offices and locations is included in the back of this document.

Technical support is available through the web site at: <http://support.microchip.com>

## DOCUMENT REVISION HISTORY

### Revision B (May 2006)

- Updated Bill of Materials (BOM) to show RoHS-compliant part numbers.

### Revision A (January 2005)

- Initial Release of this Document.

# Voltage Supervisor SOT-23-5/6 Evaluation Board User's Guide

---

NOTES:





# VOLTAGE SUPERVISOR SOT-23-5/6 EVALUATION BOARD USER'S GUIDE

---

## Chapter 1. Product Overview

---

### 1.1 INTRODUCTION

This chapter provides an overview of the Voltage Supervisor SOT-23-5/6 Evaluation Board and covers the following topics:

- What is the Voltage Supervisor SOT-23-5/6 Evaluation Board?
- What the Voltage Supervisor SOT-23-5/6 Evaluation Board Kit includes

### 1.2 WHAT IS THE VOLTAGE SUPERVISOR SOT-23-5/6 EVALUATION BOARD?

The Voltage Supervisor SOT-23-5/6 Evaluation Board allows the system designer to quickly evaluate the operation of Microchip Technology's voltage supervisors and voltage detectors in the SOT-23-5 (5-pin SOT-23) or SOT-23-6 (6-pin SOT-23) packages.

The Voltage Supervisor SOT-23-5/6 Evaluation Board Printed Circuit Board (PCB) supports the four different SOT-23-6 pinouts (which also supports compatible SOT-23-5 footprints) and one SOT-23-5 footprint.

The Voltage Supervisor SOT-23-5/6 Evaluation Board has been made generic so that other devices in the SOT-23-5 and SOT-23-6 packages may be supported with this board. Microchip device families supported include:

- Voltage Supervisors/Voltage Detectors
- Nonvolatile Digital Potentiometers (Digi-Pots)
- Operational Amplifiers (Op Amps)
- Comparators
- Low Drop-out Regulators (LDOs)
- Thermal sensors
- Analog-to-Digital Converters (ADCs)
- PFM/PWM Step-Down DC/DC Controllers
- Battery Charger Controllers
- PICmicro<sup>®</sup> Microcontrollers

### 1.3 WHAT THE VOLTAGE SUPERVISOR SOT-23-5/6 EVALUATION BOARD KIT INCLUDES

This Voltage Supervisor SOT-23-5/6 Evaluation Board Kit includes:

- Five Voltage Supervisor SOT-23-5/6 Evaluation Board PCBs
- Three voltage supervisor device samples that can be installed on the Voltage Supervisor SOT-23-5/6 Evaluation Board PCBs
- Voltage Supervisor SOT-23-5/6 Evaluation Board User's Guide (Electronic version on CD)

# Voltage Supervisor SOT-23-5/6 Evaluation Board User's Guide

---

NOTES:



# VOLTAGE SUPERVISOR SOT-23-5/6 EVALUATION BOARD USER'S GUIDE

---

---

## Chapter 2. Installation and Operation

---

---

### 2.1 INTRODUCTION

The blank Printed Circuit Board (PCB) allows the desired voltage supervisor/voltage detector device to be installed along with other desired passive components (resistors and capacitors) and connection posts.

The PCB supports four different SOT-23-6 and one SOT-23-5 pinouts. Two of these pinouts are used by the voltage supervisor/voltage detector product family, while the other pinouts are used by other Microchip analog and PICmicro<sup>®</sup> microcontroller products (see **Appendix C. "Microchip SOT-23-5/6 Device Compatibility"**). The PIC10F2XX devices uses the last pinout. This board is generic so that other devices may be supported. However, the silk-screen markings are designed for ease-of-use with the voltage supervisor devices.

### 2.2 FEATURES

The Voltage Supervisor SOT-23-5/6 Evaluation Board has the following features:

- Connection terminals may be either through-hole or surface-mount
- Four SOT-23-6 pinouts supported
  - Also supports  $V_{DD}/V_{SS}$  footprint-compatible SOT-23-5 devices
- One SOT-23-5 pinout supported
- Footprints for optional passive components for:
  - Power supply filtering
  - Device bypass capacitor
  - Output filtering
  - Output pull-up resistor
  - Output pull-down resistor
  - Output loading resistor
  - Output series resistor
- Footprints for two optional switches for:
  - Voltage supervisor manual resets
  - PIC10F2XX general purpose inputs
- Silk screen area to write specifics of implemented circuit (on back of PCB), such as TC52 2.7V, 10 k $\Omega$  (to indicate that the device is the TC52 with the 2.7V trip point and an external 10 k $\Omega$  pull-up resistor on the output)

## 2.3 GETTING STARTED

The Voltage Supervisor SOT-23-5/6 Evaluation Board is a blank PCB that allows the user to configure the circuit to their exact requirements. The passive components use the surface-mount 805 package layout. Figure 2-1 shows the board circuit.

This evaluation board supports the following Microchip device families:

- Voltage Supervisors/Voltage Detectors
- Nonvolatile Digital Potentiometers (Digi-Pots)
- Operational Amplifiers (Op Amps)
- Comparators
- Low Drop-Out Regulators (LDOs)
- Thermal Sensors
- Analog-to-Digital Converters (ADCs)
- PFM/PWM Step-Down DC/DC Controllers
- Battery Charger Controllers
- PICmicro<sup>®</sup> Microcontrollers

Table 2-1 shows these product families, the devices that are supported and which SOT-23-5/6 layout option to use. Devices that are in a 5-pin SOT-23 package can be installed into the SOT-23-6 footprint.

Table 2-2 shows which circuit option needs to be used for a given voltage supervisor/voltage detector. There are currently no voltage supervisors/voltage detectors that use the option B, C or E pinout. For other Microchip analog devices, please refer to **Appendix C. "Microchip SOT-23-5/6 Device Compatibility"**.

# Installation and Operation

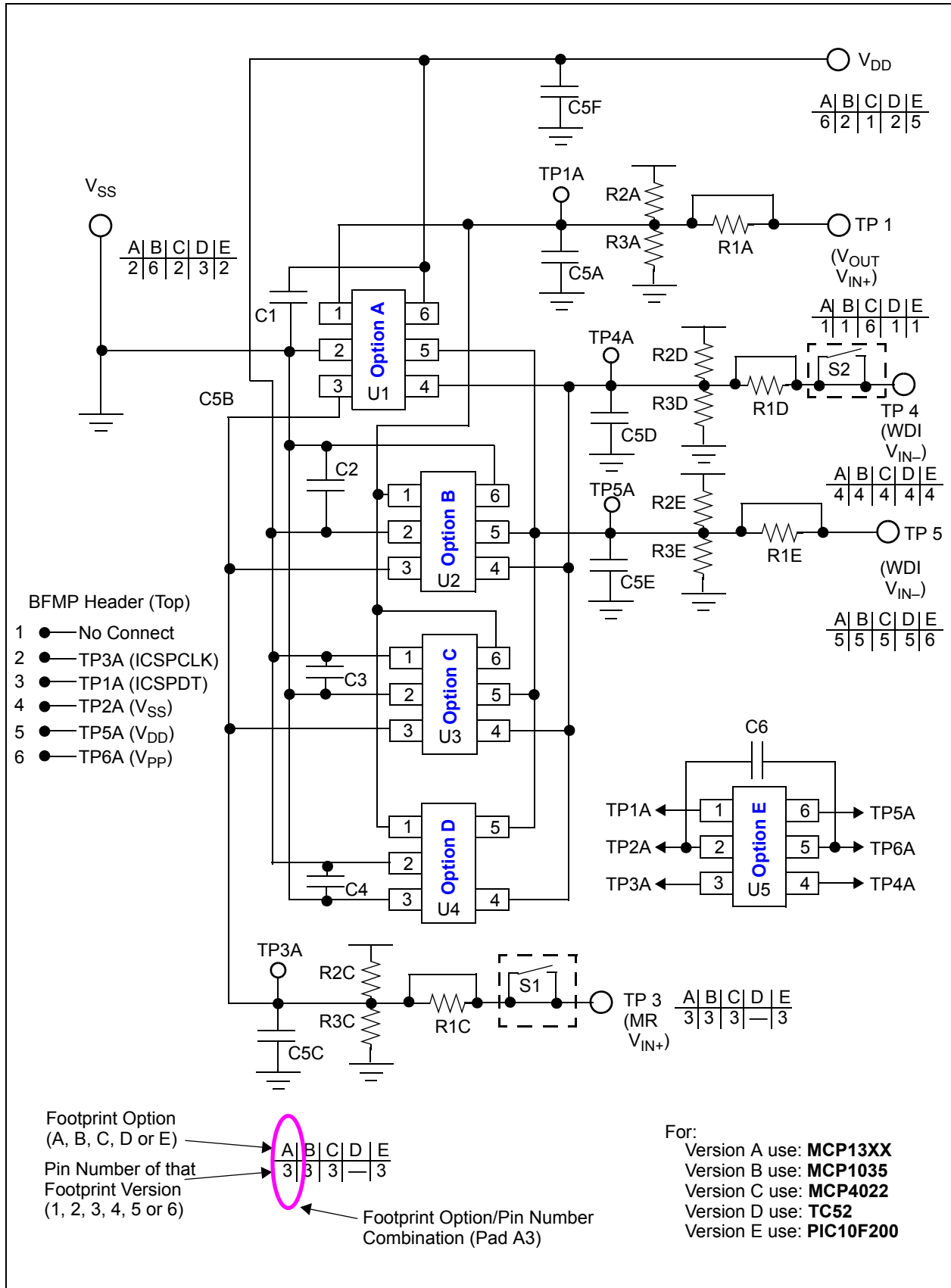

**FIGURE 2-1:** Voltage Supervisor SOT-23-5/6 Evaluation Board Circuit.

# Voltage Supervisor SOT-23-5/6 Evaluation Board User's Guide

**TABLE 2-1: SUPPORTED SOT-23-5 AND SOT-23-6 DEVICES**

Family	Device	Option	# of Pins
Voltage Supervisors/Detectors	TC52	D	5
	TC53C	D	5
	TC53N	D	5
	TC54	D	5
	MCP13XX	A	5
Digital Potentiometers (Digi-Pots) – Volatile	MCP4012	C	6
	MCP4013	C	6
	MCP4014	C	5
Digital Potentiometers (Digi-Pots) – Nonvolatile	MCP4022	C	6
	MCP4023	C	6
	MCP4024	C	5
Operational Amplifiers (Op Amps)	MCP601	A	5
	MCP601R	B	5
	MCP603	A	6
	MCP606	A	5
	MCP6001	A	5
	MCP6001R	B	5
	MCP6001U	A	5
	MCP6231	A	5
	MCP6231R	B	5
	MCP6231U	A	5
	MCP6241	A	5
	MCP6241R	B	5
	MCP6241U	A	5
	TC1034	B	5
	TC1035	B	6
Comparators	MCP6541	A	5
	MCP6541R	B	5
	MCP6546	A	5
	MCP6546R	B	5
	TC1037	A	5
	TC1038	A	6
	TC1039	A	6
Thermal Sensors	MCP9800	C	5
	MCP9802	C	5
	TC77	A	5
Analog-to-Digital Converter (ADC)	MCP3221	C	5

# Installation and Operation

**TABLE 2-1: SUPPORTED SOT-23-5 AND SOT-23-6 DEVICES (CONTINUED)**

Family	Device	Option	# of Pins
PICmicro <sup>®</sup> Microcontrollers	PIC10F200	E	6
	PIC10F202	E	6
	PIC10F204	E	6
	PIC10F206	E	6
Low Drop-Out Regulators (LDOs)	TC1014	C	5
	TC1015	C	5
	TC1017	C	5
	TC1054	C	5
	TC1055	C	5
	TC1070	C	5
	TC1071	C	5
	TC1185	C	5
	TC1186	C	5
	TC1187	C	5
	TC1223	C	5
	TC1224	C	5
	TC2014	C	5
	TC2015	C	5
	TC2054	C	5
	TC2055	C	5
TC2185	C	5	
TC2186	C	5	
PFM/PWM Step-Down DC/DC Controller	TC105	D	5
Battery Charger Controller	MCP73826	E	6

# Voltage Supervisor SOT-23-5/6 Evaluation Board User's Guide

**TABLE 2-2: VOLTAGE SUPERVISOR / VOLTAGE DETECTOR DEVICES AND EVALUATION BOARD CIRCUIT/FOOTPRINT OPTION**

Device	Supported on	Output Signal (Active State)	Output Type	Comment/Recommended Component Values
<b>MCP1316</b>	Option A	$\overline{RST}$ (L)	Push-Pull	
<b>MCP1317</b>	Option A	RST (H)	Push-Pull	
<b>MCP1318</b>	Option A	RST (H) and $\overline{RST}$ (L)	Push-Pull	
<b>MCP1319</b>	Option A	RST (H) and $\overline{RST}$ (L)	Push-Pull	
<b>MCP1320</b>	Option A	$\overline{RST}$ (L)	Open-Drain	R = TBD
<b>MCP1321</b>	Option A	RST (H) and $\overline{RST}$ (L)	Push-Pull and Open-Drain	R = TBD
<b>MCP1322</b>	Option A	RST (H) and $\overline{RST}$ (L)	Push-Pull and Open-Drain	R = TBD
<b>TC52</b>	Option D	$\overline{V_{OUT1}}$ (L), $\overline{V_{OUT2}}$ (L)	Open-Drain	$C_4 = 0.1 \mu\text{F}$ , $R_{2A} = 47 \text{ k}\Omega$ $R_{2E} = 47 \text{ k}\Omega$ , $C_1 = 1 \mu\text{F}$
<b>TC53C</b>	Option D	$\overline{V_{OUT}}$ (L)	Push-Pull	
<b>TC53N</b>	Option D	$\overline{V_{OUT}}$ (L)	Open-Drain	$R_{2A} = 47 \text{ k}\Omega$
<b>TC54VC</b>	Option D	$\overline{V_{OUT}}$ (L)	Push-Pull	
<b>TC54VN</b>	Option D	$\overline{V_{OUT}}$ (L)	Open-Drain	$R_{2A} = 47 \text{ k}\Omega$



## 2.3.1 The Hardware

Figure 2-2 shows the layout of the Voltage Supervisor SOT-23-5/6 Evaluation Board. This is a small four-layer board (1.5" x 2" (38.1 mm x 50.8 mm)). There are six connection points/pads that can use either through-hole or surface-mount connector posts.

Additionally, a test point is available between the device pin and the PCB pad that may be useful if the in-line resistor (R1A, R1C, R1D or R1E) is installed.

The different SOT-23 layout options are outlined in **Section 2.4.3 “SOT-23-6 and SOT-23-5 Footprints”**, with Opt A, Opt B, Opt C, Opt D and Opt E indicating the layout option of that SOT-23-5/6 footprint.

There are six pads on the PCB. One is labeled VDD, one is labeled VSS, with all pads having a label that indicates the footprint option used (shown as “A B C D E”) and a label underneath that indicates the pin number of that footprint. This footprint option/pin number combination will be used to indicate the remaining pads. If the device is placed in the option A footprint, the remaining pads would be A1, A3, A4 and A6, where the VDD pad is also A6 and the VSS pad is A2. Figure 2-2 has text added on each pad to show what the “pad name” would be (A1, A2, A3, A4, A5 and A6). If the device required the option C footprint, what is currently A1 for option A would then be referred to as pad C6 for option C.

Each of these four pads has four passive components associated with them. A pull-up resistor, a pull-down resistor, an in-line resistor and a filtering/load capacitor. The pull-up resistor is always R2x, the pull-down resistor is R3x, the in-line resistor is R1x and the filtering/load capacitor is C5x. The “x” is an alpha character that corresponds to a particular pad. So pad A1’s pull-up resistor is R2A.

The green area of Figure 2-2 shows the silk screen on the bottom layer of the PCB. This is where the details of the implemented circuit can be written.

Resistor R2x is a pull-up resistor that may need to be installed for devices with an open-drain output. Though resistor R3x is not currently required, it was placed for possible future requirements. Resistor R1x is not required, but may be useful if this board is to be interfaced into existing circuits. If resistor R1x is to be installed, remember to cut the trace that “shorts out” R3. Capacitors C1, C2, C3, C4, C6, C5A, C5C, C5D, C5E and C5F are bypass capacitors that may be required to be installed, depending on the device selected and the system requirements (such as the noise present on the power supply). Table 2-3 describes the components.

# Voltage Supervisor SOT-23-5/6 Evaluation Board User's Guide

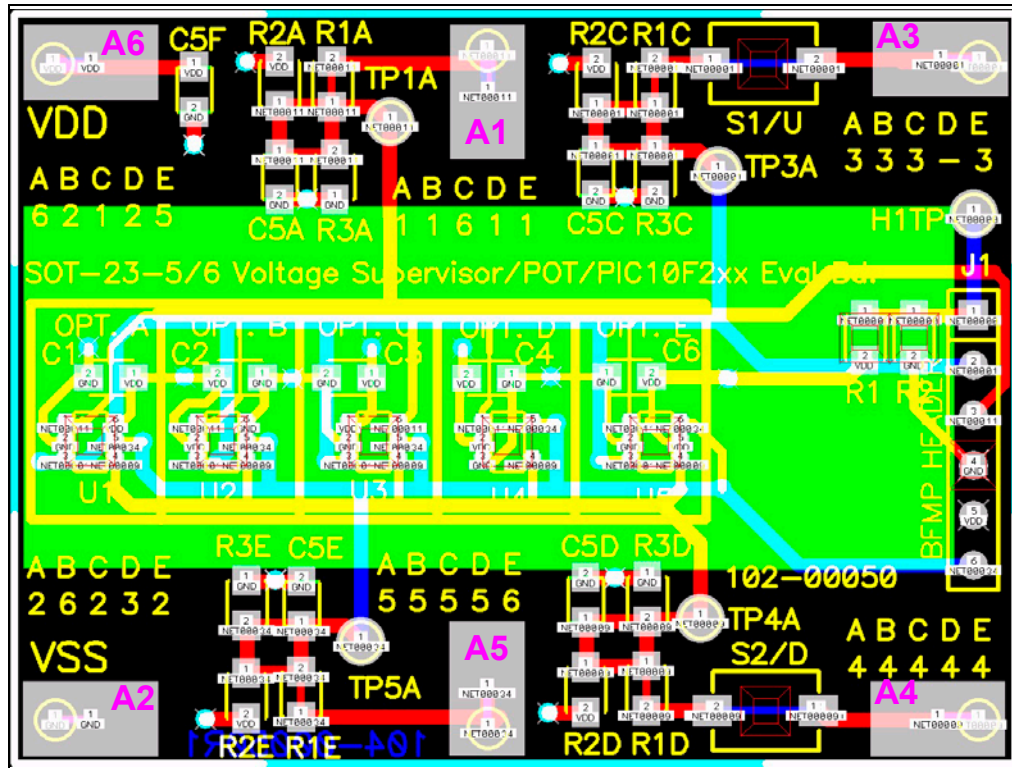

**FIGURE 2-2:** Voltage Supervisor SOT-23-5/6 Evaluation Board Layout with added "Pad Names".

**TABLE 2-3: OPTIONAL PASSIVE COMPONENTS**

Device	Comment
C1, C2, C3, C4, C5, C5F, C6	Power supply bypass capacitor
C5A, C5C, C5D, C5E	Output filter capacitor
R1, R3A, R3C, R3D, R3E	Pull-up resistor
R2, R2A, R2C, R2D, R2E	Pull-down resistor
R1A, R1C, R1D, R1E	In-line resistance of device output
S1, S2	Switches

## 2.4 VOLTAGE SUPERVISOR SOT-23-5/6 EVALUATION BOARD DESCRIPTION

The Voltage Supervisor SOT-23-5/6 Evaluation Board PCB is designed to be flexible in the type of device evaluation that can be implemented.

The following sections describe each element of this evaluation board in further detail.

### 2.4.1 Power and Ground

The Voltage Supervisor SOT-23-5/6 Evaluation Board can have connection posts installed for the power ( $V_{DD}$ ) and ground ( $V_{SS}$ ) planes. The layout allows either through-hole or surface-mount connectors.

For device evaluation, the use of an external variable power supply or waveform generator is required. The type of equipment used will determine the evaluation that may be performed.

### 2.4.2 Pads A1, A3, A4 and A5 (for Footprint Option A)

The Voltage Supervisor SOT-23-5/6 Evaluation Board can have a connection post installed for the pads A1, A3, A4 and A5 signals. Depending on the device installed, this could be an input, output or bidirectional I/O signal. The layout allows either a through-hole connector or a surface mount connector.

For device evaluation, the use of an oscilloscope or Digital Voltmeter (DVM) is required. The type of equipment used will determine the evaluation that may be performed.

## 2.4.3 SOT-23-6 and SOT-23-5 Footprints

There are four SOT-23-6 and one SOT-23-5 pinout options that the Voltage Supervisor SOT-23-5/6 Evaluation Board PCB supports. Figure 2-3 shows these four pinouts. Figure 2-4 shows the single SOT-23-5 pinout option. Some devices may use different nomenclature for the pin names, such as GND instead of  $V_{SS}$ ,  $V_{IN}$  instead of  $V_{DD}$  and RESET (or  $\overline{RESET}$ ) or  $\overline{RST}$  instead of  $V_{OUT}$ .

Other Microchip analog devices may be used with this PCB if the power and ground pins match one of these four options. **Appendix C. "Microchip SOT-23-5/6 Device Compatibility"** discusses other Microchip analog devices that may be used with this PCB.

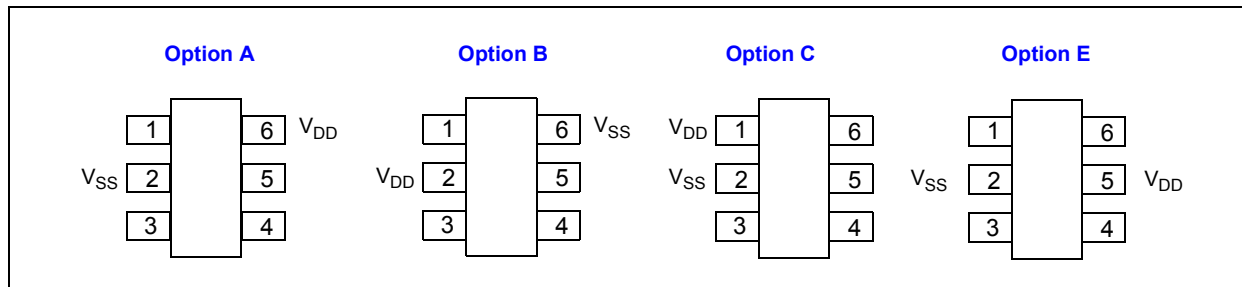

FIGURE 2-3: SOT-23-6 (and SOT-23-5) Pinout Options.

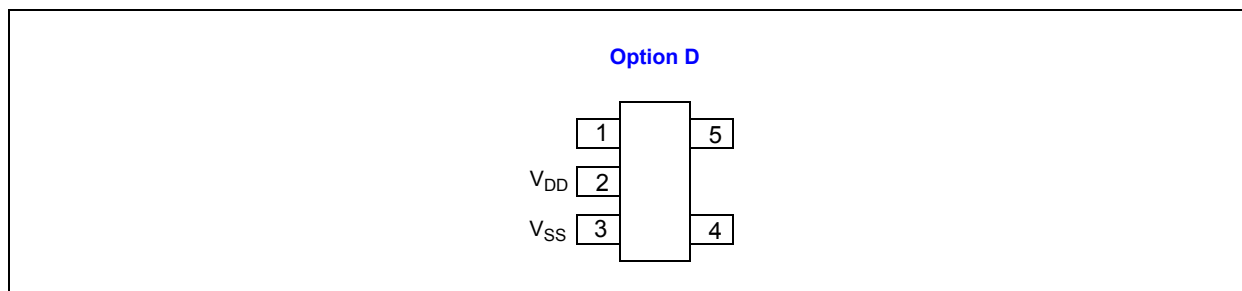

FIGURE 2-4: SOT-23-5 Pinout Option.

## 2.4.4 Passive Components (R1x, R2x, R3x, C5x, R1, R2, C1, C2, C3, C4 and C6)

The footprints for these components are present to allow maximum flexibility in the use of this PCB to evaluate a wide range of SOT-23-3 devices. The purpose of these components may vary depending on the device under evaluation and how it is to be used in the desired circuit. Please refer to the device data sheet for the recommended components that should be used when evaluating that device.

## 2.4.5 Switches (S1 and S2)

The footprints for these components are present to allow maximum flexibility in the use of this PCB to evaluate a wide range of SOT-23-5 and SOT-23-6 devices. The purpose of these components may vary depending on the device under evaluation and how it is to be used in the desired circuit. Please refer to the device data sheet for the recommended components that should be used when evaluating that device.

## 2.4.6 BFMP Interface (Header J1)

The Baseline Flash Microcontroller Programmer (BFMP) interface allows a PIC10F2XX device that is populated in the SOT-23-6 version E footprint to be programmed with programmers that support this interface, such as the BFMP programmer (part number PG164101).

## 2.5 VOLTAGE SUPERVISOR/VOLTAGE DETECTOR CIRCUITS

Currently, the voltage detectors/voltage supervisors use either footprint option A or footprint option D.

### 2.5.1 Option D Circuit

Using the TC53C or TC54VC, no passive components would be required and the device  $V_{OUT}$  could be monitored on the D1 pad.

Using the TC53N or TC54VN, an external pull-up resistor is required. This resistor would be installed in the R2A location and the device  $V_{OUT}$  could be monitored on the D1 pad.

The TC52 is a dual-channel voltage detector. This means that the device has a  $V_{OUT1}$  and a  $V_{OUT2}$  output. Both outputs are open-drain and require a pull-up resistor. Locations R2A and R2E should be installed with 47 k $\Omega$  resistors.

Detect voltage 2 ( $V_{OUT2}$ ) is lower than detect voltage 1 ( $V_{OUT1}$ ). Therefore,  $V_{OUT1}$  is typically used to indicate a low-power situation, with  $V_{OUT2}$  being used to reset the system. Typically, a 0.1  $\mu$ F capacitor would be on the  $V_{OUT2}$  pin (installed in the C5E location).

Power supply filtering may be required, so a 0.1  $\mu$ F capacitor is suggested in the C4 location.

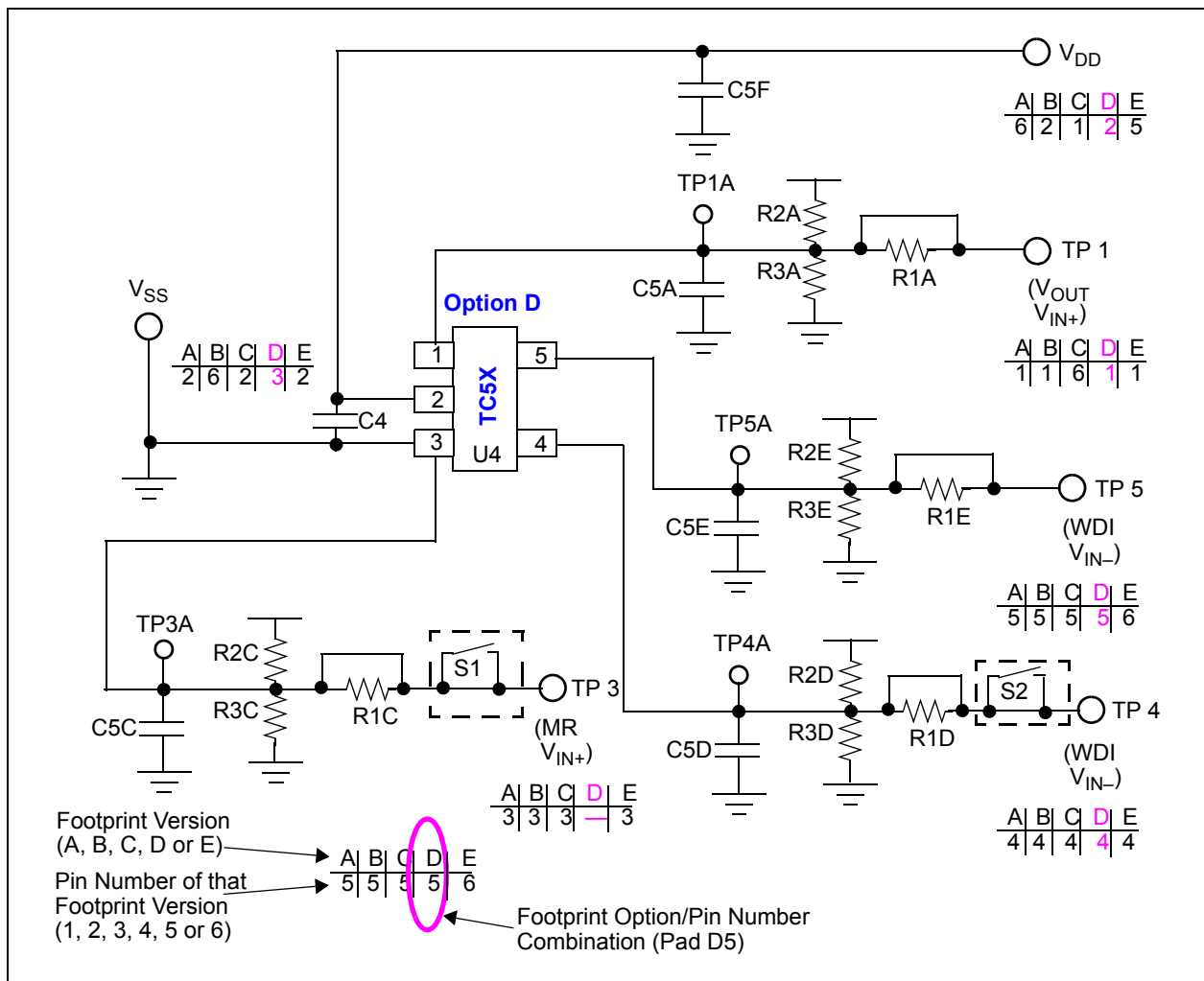
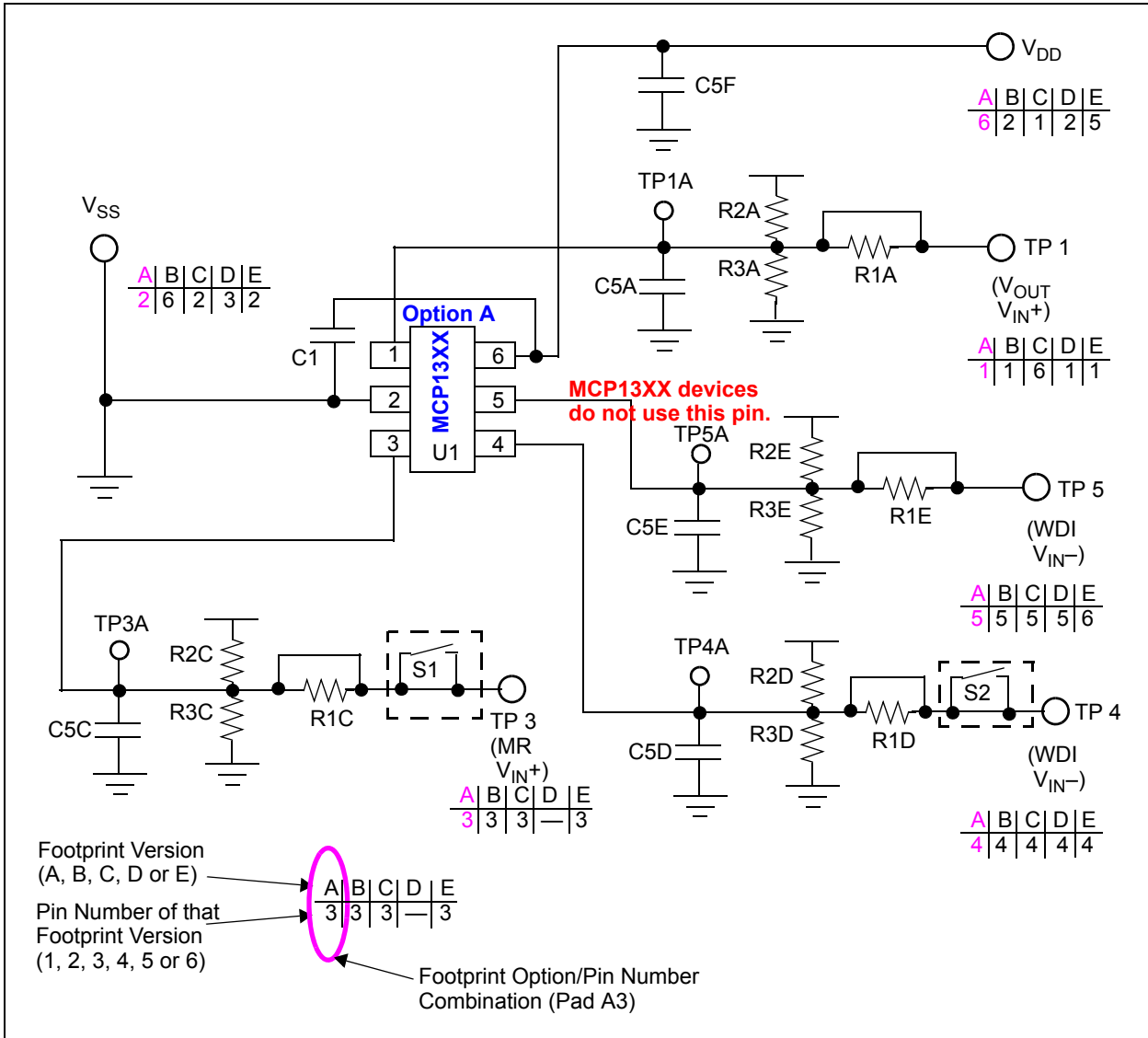

**FIGURE 2-5:** Voltage Supervisor Circuit using Option D Footprint.

# Voltage Supervisor SOT-23-5/6 Evaluation Board User's Guide

## 2.5.2 Option A Circuit

The MCP13XX devices are only in the SOT-23-5 (5-pin) package, therefore option A footprint pin 5 is not connected to the device. Once the device is released, please refer to the data sheet to determine your desired circuit.



**FIGURE 2-6:** Voltage Supervisor Circuit using Option A Footprint.

# Installation and Operation

## 2.5.3 A Circuit with the PIC10F200 and a Voltage Supervisor (MCP13XX)

The PIC10F200 can be used to show the operation of the Watchdog Timer feature (WDI) or the Manual Reset (MR) inputs that are available on some of the MCP13XX devices.

Figure 2-7 shows the schematic to interface the appropriate MCP13XX device to the PIC10F200 to exercise the Watch Dog Timer (WDI) and Manual Reset (MR) functionality of the device.

After the release of the MCP13XX devices, please check the Microchip web site for an application note or technical brief that will demonstrate one of the MCP13XX devices using the Voltage Supervisor SOT-23-5/6 Evaluation Board.

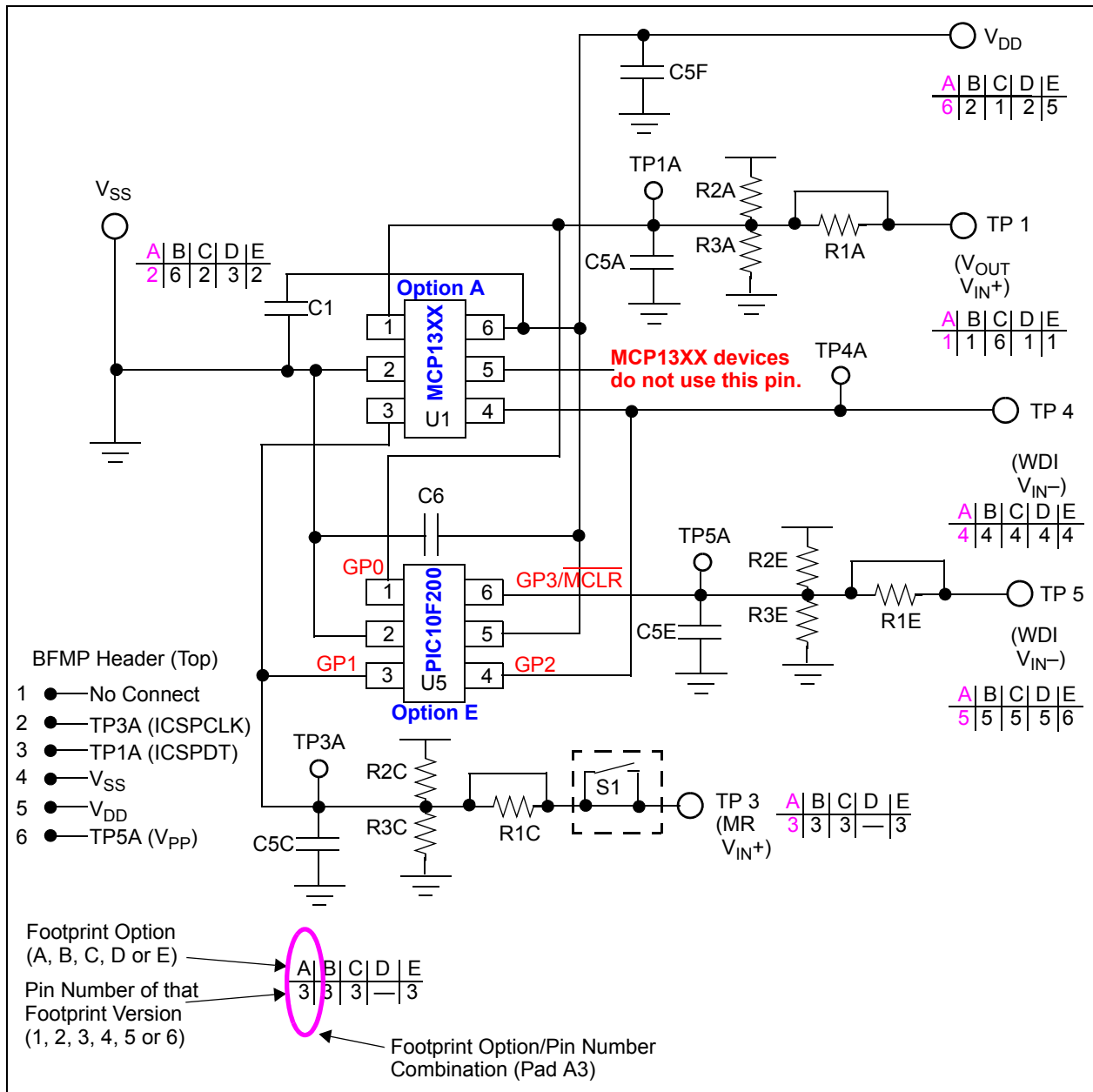

**FIGURE 2-7:** MCP13XX and a PIC10F200 Circuit.

# Voltage Supervisor SOT-23-5/6 Evaluation Board User's Guide

## 2.5.4 Evaluating a Voltage Supervisor or Voltage Detector Device

When evaluating a voltage supervisor/voltage detector device, a minimum set of test equipment should be available. Table 2-4 shows the recommended test equipment.

**TABLE 2-4: TEST EQUIPMENT**

Hardware	Connect to:	Comment
Variable Power Supply	VDD, VSS	This allows the voltage to the SOT23 Evaluation Board to be varied so the device output can be monitored.
Arbitrary Waveform Generator	VDD, VSS	This is like a variable power supply, but allows programmability into the input signal that the device will be subjected to. This also allows a particular waveform to be repeated (such as a 60 Hz sine wave that varies from 1V to 5V).
Digital Multi-Meter (D.M.M.)	V <sub>OUT</sub> <sup>(1)</sup>	Used to indicate the output state (low or high) of the voltage supervisor/voltage detector.
Oscilloscope	V <sub>OUT</sub> <sup>(1)</sup>	Allows the device conditions and response to be evaluated due to the ability to capture this information. This is useful for faster signals and cases where small spikes need to be detected.
Test Light (LED)	V <sub>OUT</sub> <sup>(1)</sup>	Used to visually indicate the output state (low or high) of the voltage supervisor/voltage detector. Ensure that the current requirements of this LED can be supplied by the device's output pin.

**Note 1:** The pad connection to connect to the V<sub>OUT</sub> or RST pin will be dependent on the device and the footprint option used.

A typical system that would be used to evaluate the voltage supervisor or voltage detector device is shown in Figure 2-8. This also shows an example of input and output waveforms for a voltage supervisor or voltage detector device.

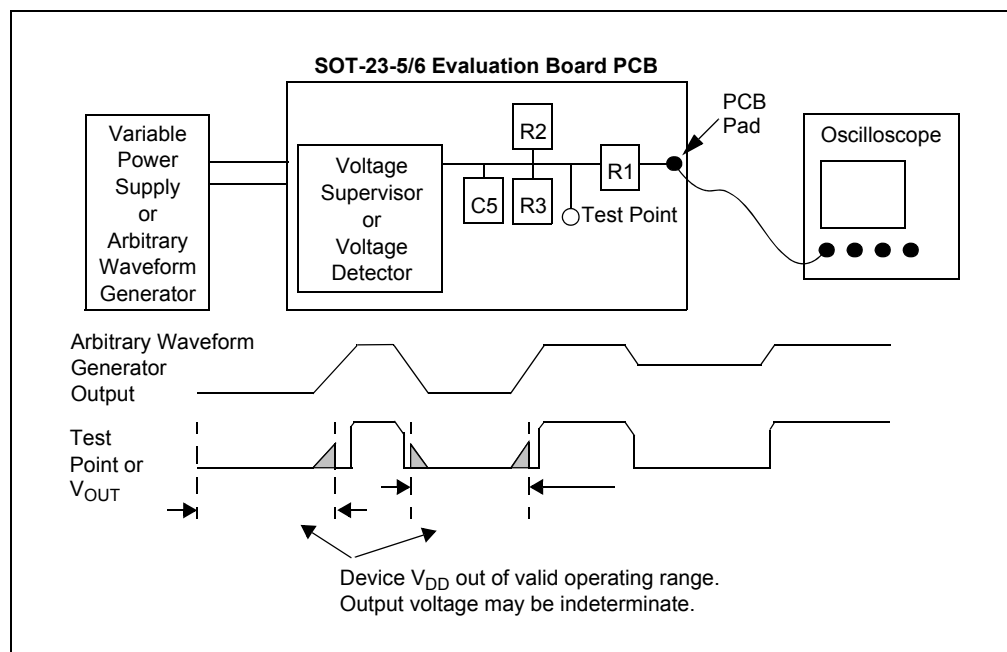

**FIGURE 2-8:** Evaluation System.



## 2.6 DIGITAL POTENTIOMETER CIRCUIT

The Voltage Supervisor SOT-23-5/6 Evaluation Board can be utilized to demonstrate and test Microchip's SOT-23-5 and SOT-23-6 nonvolatile digital potentiometers. This is accomplished by populating the PCB with the desired MCP401X or MCP402X device, a PIC10F2XX microcontroller, two momentary switches and a few resistors.

**Note:** Microchip Technology Inc. offers a built-up evaluation board for the MCP402X Digital Potentiometer (MCP402XEV). Additional information regarding this evaluation board may be found on the CD-ROM directory: CD-ROM:\00066 - MCP402X Digital Potentiometer Evaluation Board. Within this directory, you will find the user's guide for this evaluation board, the PIC10F200 program (firmware) and assembled HEX file (00066\_MCP402XEV.hex).

The code supplied for this evaluation board may be easily modified to demonstrate operation of the Voltage Supervisor SOT-23-5/6 Evaluation Board.

Section 2.3 and Section 2.4 of the MCP401X/2X Digital Potentiometer Evaluation Board User's Guide (DS51546) discuss the MCP402XEV firmware. This firmware can easily be modified to demonstrate using the Voltage Supervisor SOT-23-5/6 Evaluation Board.

Figure 2-9 illustrates an example circuit. This circuit uses the MCP4023 and PIC10F200 devices with all the components installed. The PCB silk-screen indicates the VDD and VSS pads. The remaining PCB pads will be referred to by their footprint option/pin number combination. These combinations are C3, C4, C5 and C6.

The PIC10F2XX will need to be programmed to make the system work. The PIC10F2XX device can be programmed via the Baseline Flash Microcontroller Programmer (BFMP) header (J1). The program (firmware) configures the GP1 and GP2 pins to be outputs (driving high) and the GP0 and GP3 pins to be inputs. The GP1 and GP2 pins are individually polled to determine if either switch S1/D (down) and S2/U (up) are depressed.

If the nonvolatile MCP402X device is used, the digital potentiometer setting can be stored in nonvolatile memory, power can be cycled and the digital potentiometer will be at the last saved setting for the volatile versions of the device. The wiper will go to its default setting when power is cycled.

**Note:** The PIC10F2XX program (firmware) must take care in the timing requirements of the GP1 and GP2 pins, due to the multiplexing of the PIC10F2XX GP1 pin with the MCP4023 U/D pin and Switch S1, and the multiplexing of the PIC10F2XX GP2 pin with the MCP4023 CS pin and switch S2.



---

## Appendix A. Schematics and Layouts

---

### A.1 INTRODUCTION

This appendix contains the schematics and layouts for the Voltage Supervisor SOT-23-5/6 Evaluation Board. Diagrams included in this appendix:

- Board Schematic - Digital Circuitry
- Board - Top Layer

### A.2 SCHEMATICS AND PCB LAYOUT

Figure A.3 shows the schematic of the Voltage Supervisor SOT-23-5/6 Evaluation Board.

Figure A.4 shows the layout for the top layer of the Voltage Supervisor SOT-23-5/6 Evaluation Board. The layer order is shown in Figure A-1.

**FIGURE A-1: LAYER ORDER**

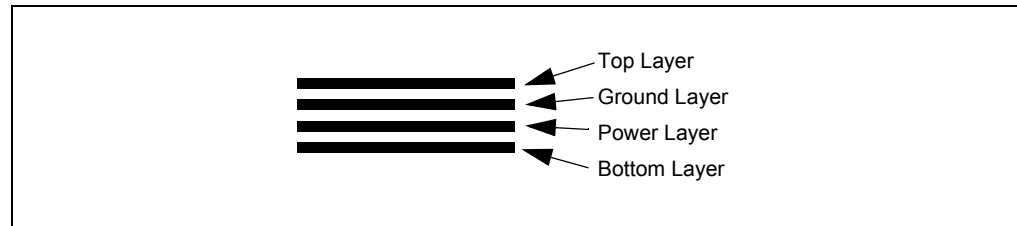

# Voltage Supervisor SOT-23-5/6 Evaluation Board User's Guide

## A.3 SCHEMATIC

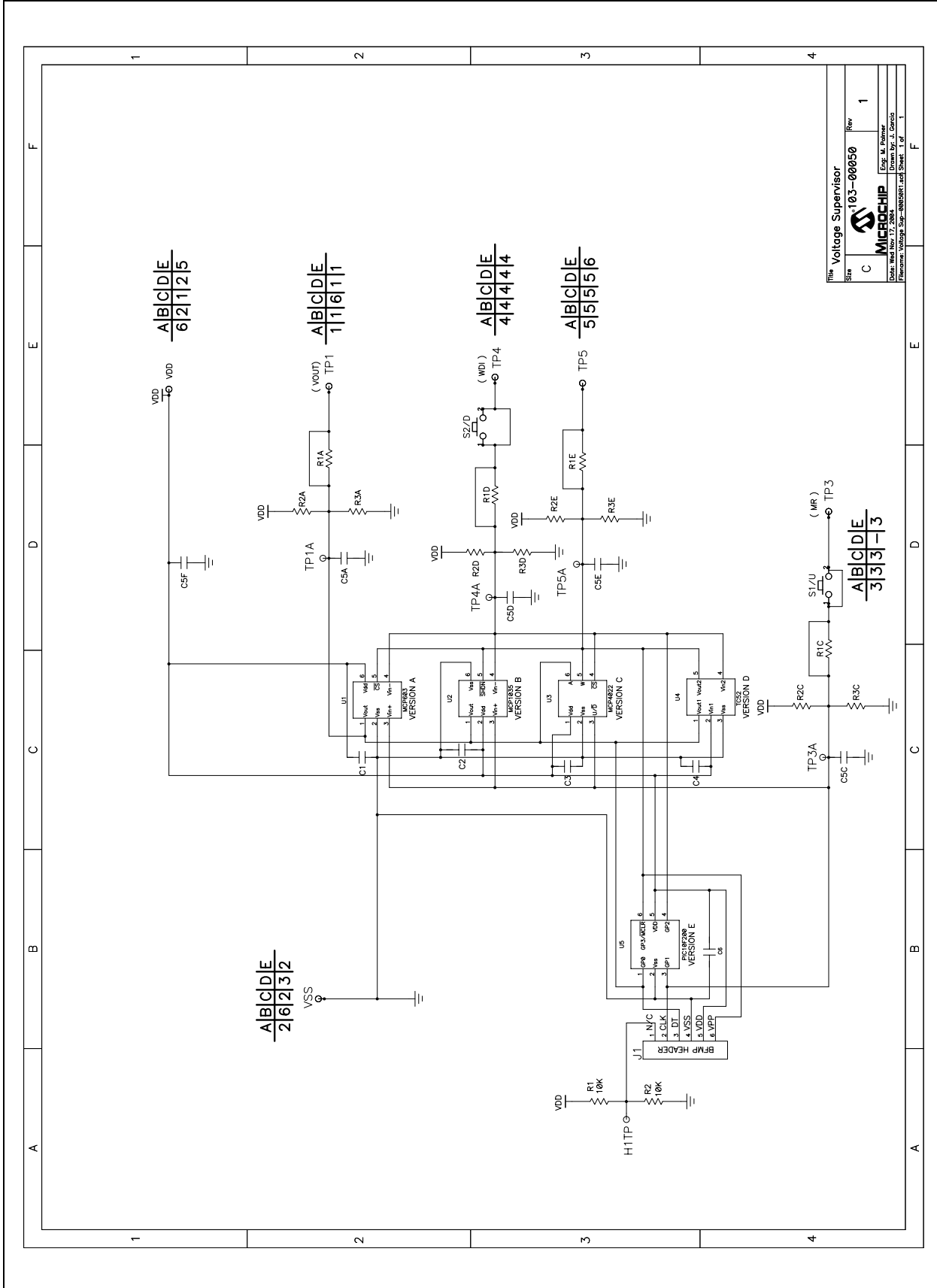

## A.4 BOARD LAYOUT – TOP LAYER, BOTTOM LAYER AND SILK SCREEN

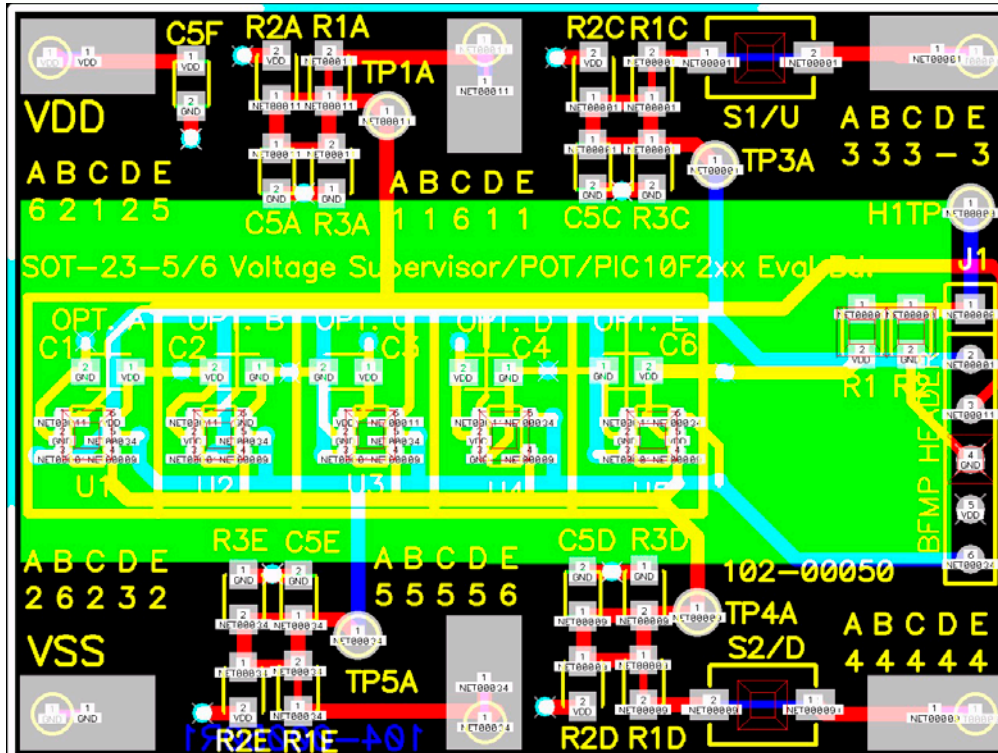

A.5 BOARD LAYOUT – TOP LAYER AND SILK-SCREEN

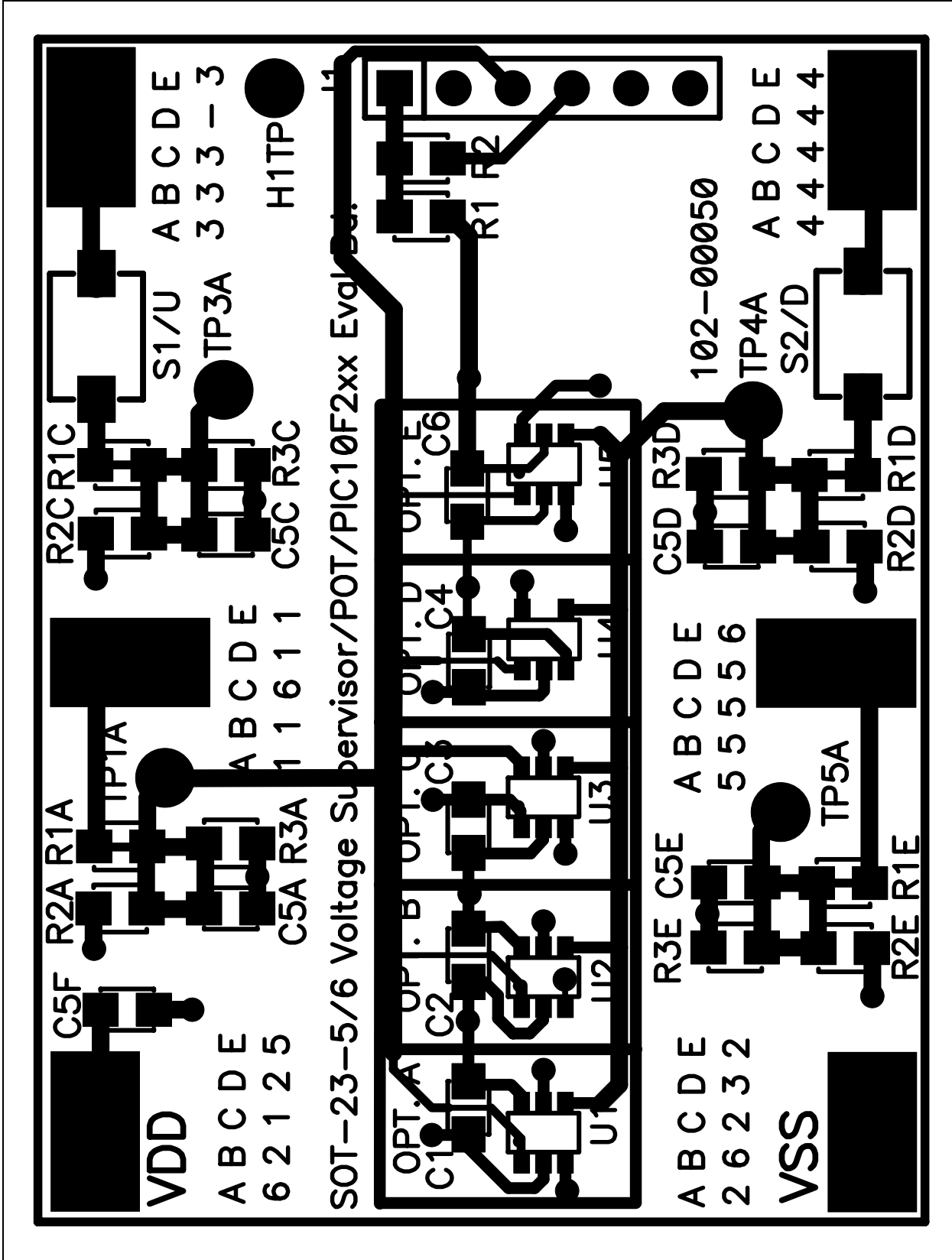

## A.6 BOARD LAYOUT – BOTTOM LAYER

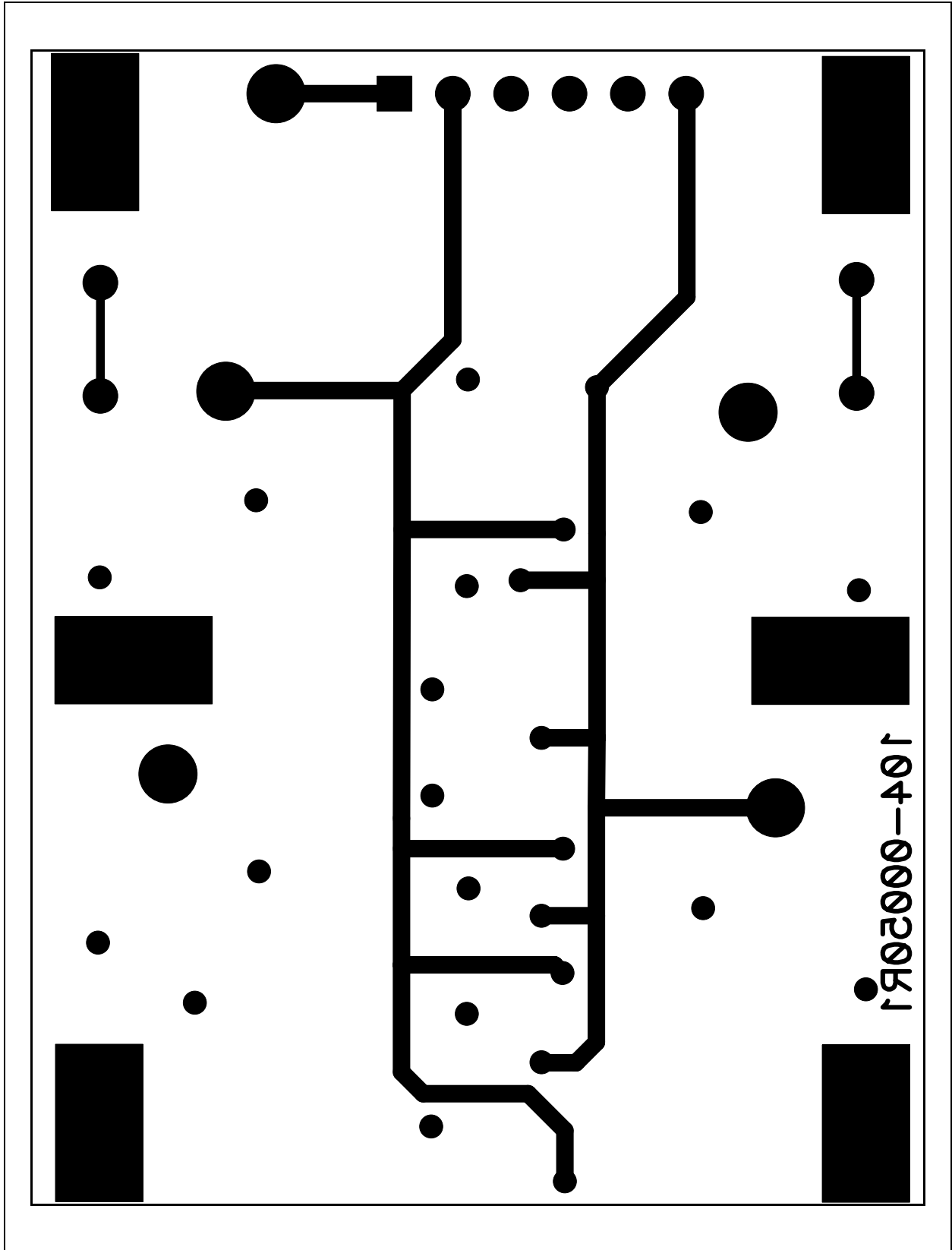

## A.7 BOARD LAYOUT – GROUND PLANE

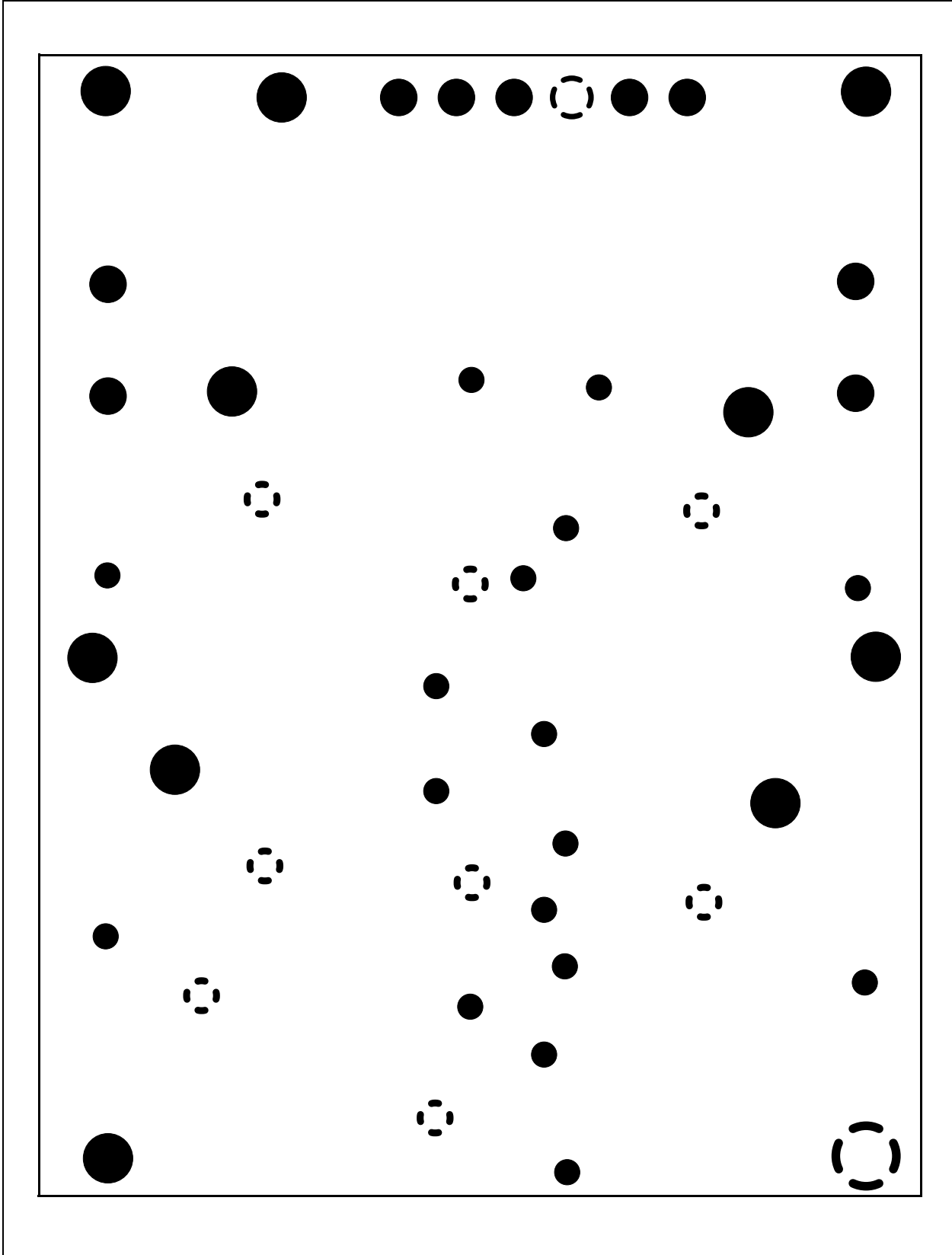



## A.8 BOARD LAYOUT – POWER LAYER

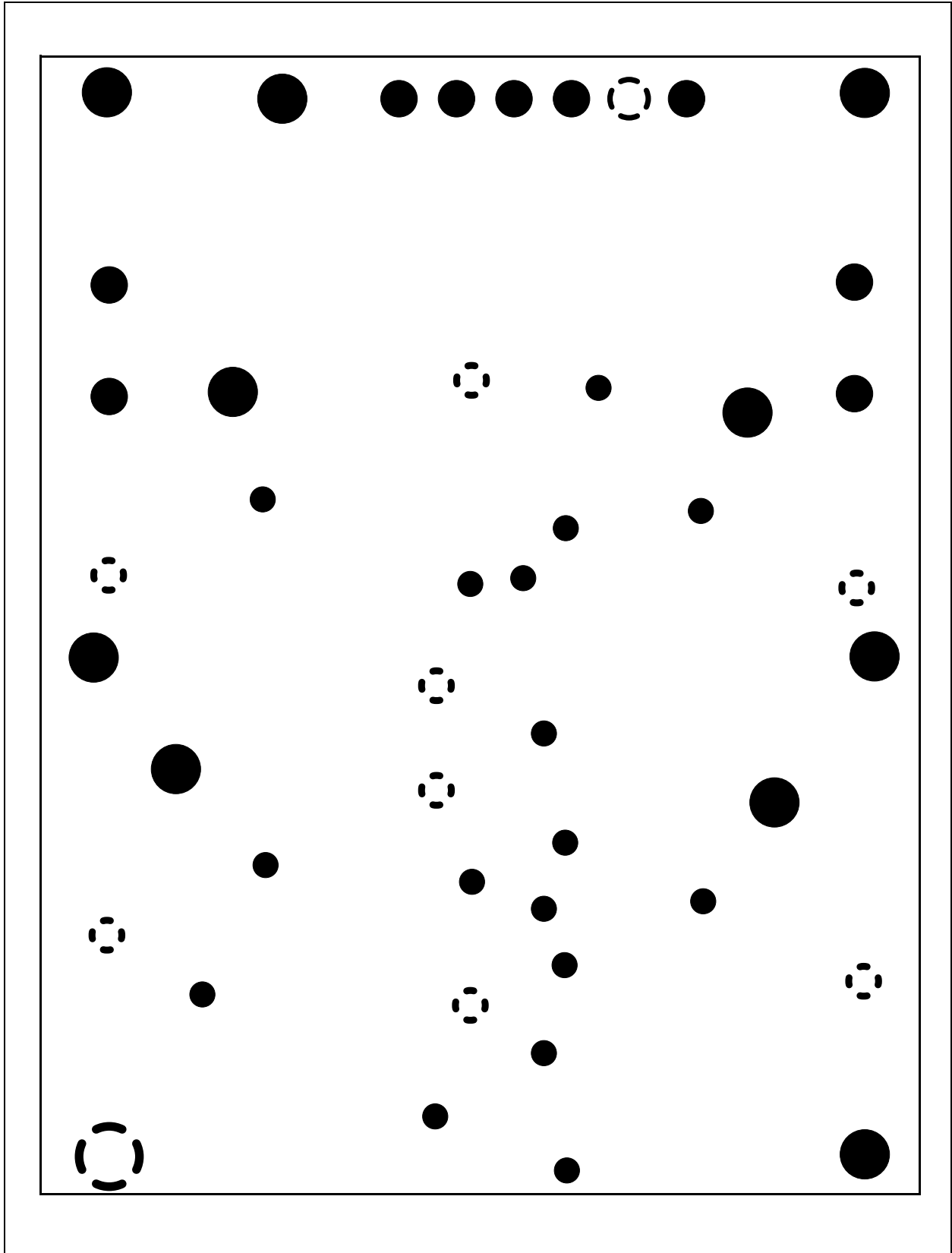

A.9 BOARD LAYOUT – TOP COMPONENTS AND SILK SCREEN

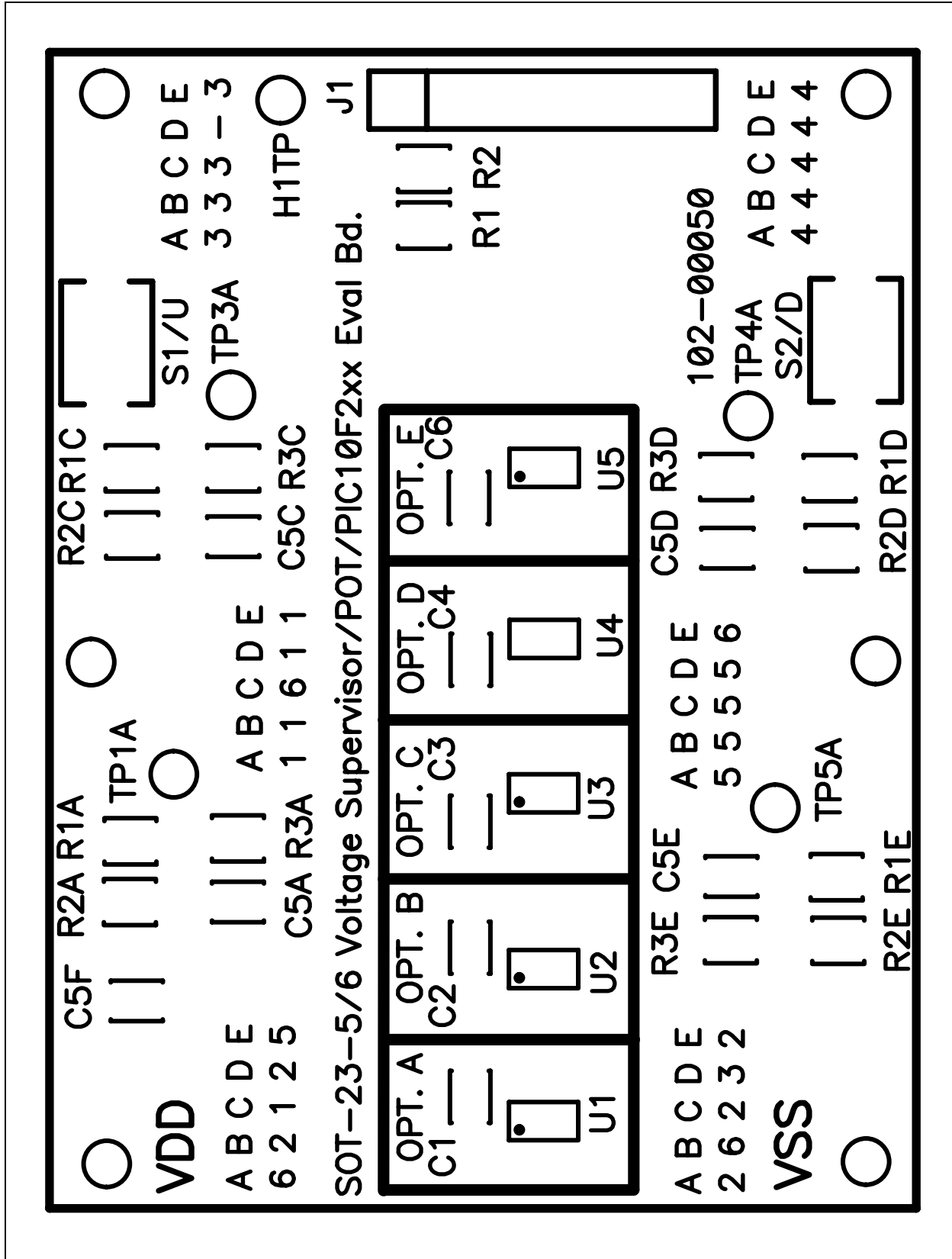



# VOLTAGE SUPERVISOR SOT-23-5/6 EVALUATION BOARD USER'S GUIDE

## Appendix B. Bill Of Materials (BOM)

TABLE B-1: BILL OF MATERIALS

Qty	Reference	Description	Manufacturer	Part Number
1	PCB 103-00050	Voltage Supervisor SOT-23-5/6 Evaluation Board PCB	Microchip Technology Inc.	103-00050
0	U1, U2, U3, U5	SOT-23-6 Device (Only one of U1 - U5 installed per board)	Microchip Technology Inc.	User-specified
0	U4	SOT-23-5 Device (Only one of U1 - U5 installed per board)	Microchip Technology Inc.	User-specified
0	C1, C2, C3, C4, C6	Device Power Supply Bypass Capacitor Surface-mount (805 package) (Optional - Application-dependent)	—	User-specified
0	C5F	Power Supply Bypass Capacitor Surface-mount (805 package) (Optional - Application-dependent)	—	User-specified
0	C5A, C5C, C5D, C5E	Output Filter Capacitor Surface-mount (805 package) (Optional - Application-dependent)	—	User-specified
0	R2A, R2C, R2D, R2E	Output Pull-up resistor Surface-mount (805 package) (Optional - Application-dependent)	—	User-specified
0	R3A, R3C, R3D, R3E	Output Pull-down resistor Surface-mount (805 package) (Optional - Application-dependent)	—	User-specified
0	R1A, R1C, R1D, R1E	Output inline resistor Surface-mount (805 package) (Optional - Application-dependent)	—	User-specified
0	R1	BFMP Header pin 1 pull up resistor <sup>(2)</sup>	—	—
0	R2	BFMP Header pin 1 pull down resistor <sup>(2)</sup>	—	—
0	J1	BFMP Header (6-pin, 100 mil spacing)	—	—
0	TP1A, TP3A, TP4A, TP5A, H1TP	Through-hole Test Point connector	Keystone Electronics®	5012
0	S1, S2 <sup>(3)</sup>	Through-hole Switch <sup>(3)</sup>	Panasonic®	EVQ-ATA048
0	S1, S2	Surface-mount Switch	Panasonic	EVQ-PJ504K
0	V <sub>DD</sub> , V <sub>SS</sub> , A1 <sup>(1)</sup> , A3 <sup>(1)</sup> , A4 <sup>(1)</sup> , A5 <sup>(1)</sup>	V <sub>DD</sub> , V <sub>SS</sub> and the other PCB Pads (A1 <sup>(1)</sup> , A3 <sup>(1)</sup> , A4 <sup>(1)</sup> , A5 <sup>(1)</sup> ) through-hole connector	Keystone Electronics®	5012
0	V <sub>DD</sub> , V <sub>SS</sub> , A1 <sup>(1)</sup> , A3 <sup>(1)</sup> , A4 <sup>(1)</sup> , A5 <sup>(1)</sup>	V <sub>DD</sub> , V <sub>SS</sub> and the other PCB Pads (A1 <sup>(1)</sup> , A3 <sup>(1)</sup> , A4 <sup>(1)</sup> , A5 <sup>(1)</sup> ) surface-mount connector	Keystone Electronics®	5016

- Note 1:** This reference is a description of the silk screen name “A B C D E” that matches the footprint version option to the package pin number (“1 2 3 4 5 6”).  
For example, A1 means footprint version option A, package pin number 1.
- 2:** The current BFMP programming specifications has pin 1 (J1-1) unconnected. These footprints are to support possible future functionality enhancements.
- 3:** Revision 1 of the PCB has through-holes that are too small to support this switch. For Revision 1 boards, please use surface-mount switches.

# Voltage Supervisor SOT-23-5/6 Evaluation Board User's Guide

---

NOTES:

## Appendix C. Microchip SOT-23-5/6 Device Compatibility

### C.1 INTRODUCTION

This appendix documents other Microchip analog devices that can be evaluated using the Voltage Supervisor SOT-23-5/6 Evaluation Board. New devices may be introduced after the publication of this document that may be supported. Compare the pinout of the device to the PCB schematic/layout to determine compatibility of any SOT-23-5 (5-pin SOT-23) or SOT-23-6 (6-pin SOT-23) packaged device.

### C.2 PCB COMPATIBILITY

There are four SOT-23-6 (6-pin SOT-23) pinouts that the Voltage Supervisor SOT-23-5/6 Evaluation Board PCB supports. Figure C-1 shows these four pinouts. There is an additional SOT-23-5 (5-pin SOT-23) pinout that the Voltage Supervisor SOT-23-5/6 Evaluation Board PCB supports. Figure C-2 shows this pinout. Other Microchip analog devices may be used with this PCB if the power and ground pins match these available options. Though these devices may use different nomenclature for the pin names, as long as the power and ground signals match one of the four options, this PCB should be able to be used to evaluate that device.

Table C-1 shows the Microchip analog device part number, the analog family the device belongs to, which footprint option to use and the recommended components to use for the circuit. Please refer to the device data sheet for complete information on the application circuit.

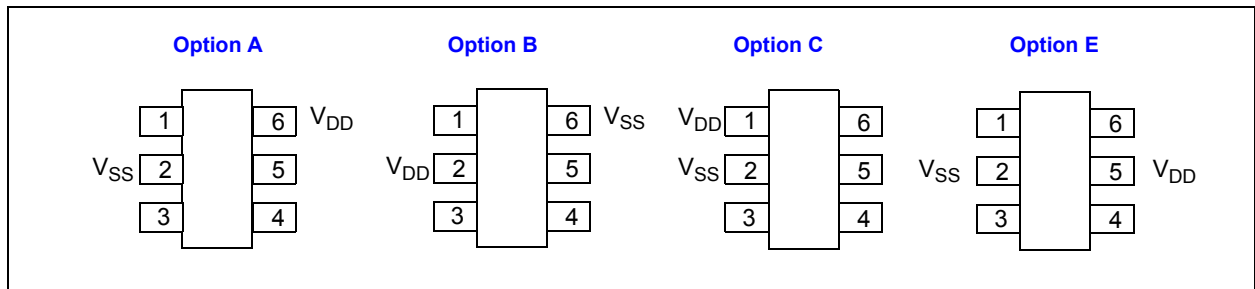

**FIGURE C-1:** SOT-23-6 (and SOT-23-5) Pinout Options.

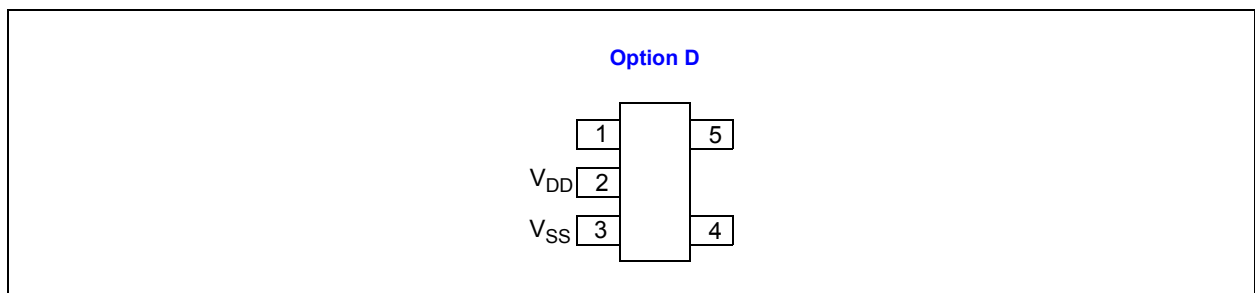

**FIGURE C-2:** SOT-23-5 Pinout Option.

# Voltage Supervisor SOT-23-5/6 Evaluation Board User's Guide

**TABLE C-1: MICROCHIP ANALOG AND PIC<sup>®</sup>MICRO DEVICES AND SOT-23-5/6 EVALUATION BOARD CIRCUIT/FOOTPRINT OPTION SELECTION**

Device Family	Device	Option Supported On	# of Pins	Comment Recommended Component Values:
Digital Potentiometers (Digi-Pots) – Volatile	MCP4012	C	6	See Device Data Sheet (DS21978) for recommended components
	MCP4013	C	6	See Device Data Sheet (DS21978) for recommended components
	MCP4014	C	5	See Device Data Sheet (DS21978) for recommended components
Digital Potentiometers (Digi-Pots) – Nonvolatile	MCP4022	C	6	See Device Data Sheet (DS21916) for recommended components
	MCP4023	C	6	See Device Data Sheet (DS21916) for recommended components
	MCP4024	C	5	See Device Data Sheet (DS21916) for recommended components
Operational Amplifiers (Op Amps)	MCP601	A	5	See Device Data Sheet (DS21314) for recommended components
	MCP601R	B	5	See Device Data Sheet (DS21314) for recommended components
	MCP603	A	6	See Device Data Sheet (DS21314) for recommended components
	MCP606	A	5	See Device Data Sheet (DS11177) for recommended components
	MCP6001	A	5	See Device Data Sheet (DS21733) for recommended components
	MCP6001R	B	5	See Device Data Sheet (DS21733) for recommended components
	MCP6001U	A	5	See Device Data Sheet (DS21733) for recommended components
	MCP6231	A	5	See Device Data Sheet (DS21881) for recommended components
	MCP6231R	B	5	See Device Data Sheet (DS21881) for recommended components
	MCP6231U	A	5	See Device Data Sheet (DS21881) for recommended components
	MCP6241	A	5	See Device Data Sheet (DS21882) for recommended components
	MCP6241R	B	5	See Device Data Sheet (DS21882) for recommended components
	MCP6241U	A	5	See Device Data Sheet (DS21882) for recommended components
	TC1034	B	5	See Device Data Sheet (DS21343) for recommended components
	TC1035	B	6	See Device Data Sheet (DS21343) for recommended components

# Microchip SOT-23-5/6 Device Compatibility

**TABLE C-1: MICROCHIP ANALOG AND PIC® MICRO DEVICES AND SOT-23-5/6 EVALUATION BOARD CIRCUIT/FOOTPRINT OPTION SELECTION (CONTINUED)**

Device Family	Device	Option Supported On	# of Pins	Comment Recommended Component Values:
Comparators	MCP6541	A	5	See Device Data Sheet (DS21696) for recommended components
	MCP6541R	B	5	See Device Data Sheet (DS21696) for recommended components
	MCP6546	A	5	See Device Data Sheet (DS21714) for recommended components
	MCP6546R	B	5	See Device Data Sheet (DS21714) for recommended components
	TC1037	A	5	See Device Data Sheet (DS21344) for recommended components
	TC1038	A	6	See Device Data Sheet (DS21344) for recommended components
	TC1039	A	6	See Device Data Sheet (DS21344) for recommended components
Thermal Sensors	MCP9800	C	5	C3 = 0.1 $\mu$ F R2C = 10 k $\Omega$ R2D = 10 k $\Omega$ R2A = 10 k $\Omega$
	MCP9802	C	5	C3 = 0.1 $\mu$ F R2C = 10 k $\Omega$ R2D = 10 k $\Omega$ R2A = 10 k $\Omega$
	TC77	A	5	C1 = 0.1 $\mu$ F
A/D Converter (ADC)	MCP3221	C	5	See Device Data Sheet (DS21732) for recommended components

# Voltage Supervisor SOT-23-5/6 Evaluation Board User's Guide

**TABLE C-1: MICROCHIP ANALOG AND PIC® MICRO DEVICES AND SOT-23-5/6 EVALUATION BOARD CIRCUIT/FOOTPRINT OPTION SELECTION (CONTINUED)**

Device Family	Device	Option Supported On	# of Pins	Comment Recommended Component Values:
Low Drop-Out Regulators (LDOs)	TC1014	C	5	C3 = 1 $\mu$ F C5A = 1 $\mu$ F C5D = 470 pF Pad C3 (schematic TP3) connected to pad $V_{DD}$
	TC1015	C	5	See Device Data Sheet (DS21335) for recommended components
	TC1017	C	5	See Device Data Sheet (DS21813) for recommended components
	TC1054	C	5	See Device Data Sheet (DS21350) for recommended components
	TC1055	C	5	See Device Data Sheet (DS21350) for recommended components
	TC1070	C	5	See Device Data Sheet (DS21353) for recommended components
	TC1071	C	5	See Device Data Sheet (DS21353) for recommended components
	TC1185	C	5	See Device Data Sheet (DS21350) for recommended components
	TC1186	C	5	See Device Data Sheet (DS21353) for recommended components
	TC1187	C	5	See Device Data Sheet (DS21368) for recommended components
	TC1223	C	5	See Device Data Sheet (DS21368) for recommended components
	TC1224	C	5	See Device Data Sheet (DS21368) or recommended components
	TC2014	C	5	See Device Data Sheet (DS21662) for recommended components
	TC2015	C	5	See Device Data Sheet (DS21662) for recommended components
	TC2054	C	5	See Device Data Sheet (DS21663) for recommended components
	TC2055	C	5	See Device Data Sheet (DS21663) for recommended components
	TC2185	C	5	See Device Data Sheet (DS21662) for recommended components
	TC2186	C	5	See Device Data Sheet (DS21663) for recommended components
PICmicro® Microcontrollers	PIC10F200	E	6	C6 = 1 $\mu$ F
	PIC10F202	E	6	C6 = 1 $\mu$ F
	PIC10F204	E	6	C6 = 1 $\mu$ F
	PIC10F206	E	6	C6 = 1 $\mu$ F
PFM/PWM Step-Down DC/DC Controller	TC105	D	5	See Device Data Sheet (DS21349) for recommended components
Battery Charger Controller	MCP73826	E	6	See Device Data Sheet (DS21705) for recommended components



## C.3 IDEAS ON EVALUATING AN LDO

One of the characteristics that a designer may wish to evaluate on a LDO is how the LDO responds to transient loads. Figure C-3 shows a system block diagram for evaluating a LDO and a typical waveform response (at test point) for the function generator signal. The output of the function generator connects to a BJT transistor to simulate the fast switching loads of the circuit.

The value of  $C_2$ ,  $R_3$  and  $C_L$  will depend on the LDO used and the load of the circuit. Look at both the worst-case amplitude load requirements for a loaded and unloaded system. As the output response of the LDOs become faster, the selection of a smaller (cheaper) output load capacitor ( $C_L$ ) becomes possible (for the same system performance).

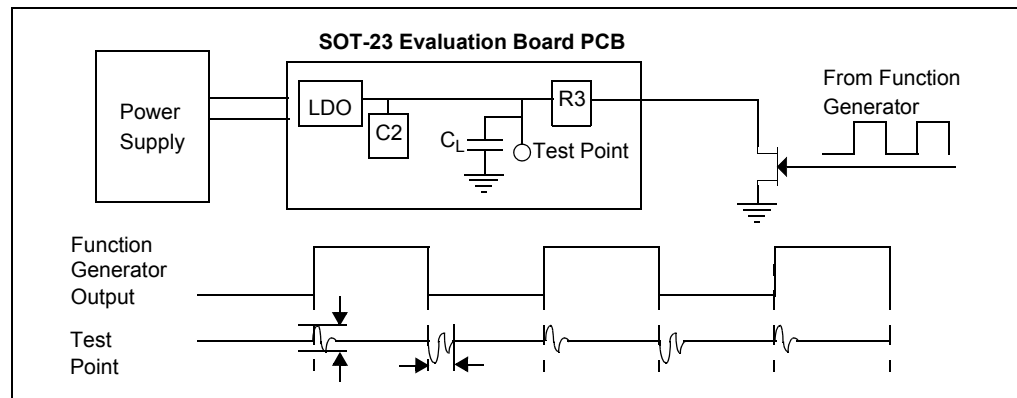

**FIGURE C-3:** LDO Evaluation System.



**MICROCHIP**

## WORLDWIDE SALES AND SERVICE

### AMERICAS

**Corporate Office**  
2355 West Chandler Blvd.  
Chandler, AZ 85224-6199  
Tel: 480-792-7200  
Fax: 480-792-7277  
Technical Support:  
<http://support.microchip.com>  
Web Address:  
[www.microchip.com](http://www.microchip.com)

#### Atlanta

Alpharetta, GA  
Tel: 770-640-0034  
Fax: 770-640-0307

#### Boston

Westborough, MA  
Tel: 774-760-0087  
Fax: 774-760-0088

#### Chicago

Itasca, IL  
Tel: 630-285-0071  
Fax: 630-285-0075

#### Dallas

Addison, TX  
Tel: 972-818-7423  
Fax: 972-818-2924

#### Detroit

Farmington Hills, MI  
Tel: 248-538-2250  
Fax: 248-538-2260

#### Kokomo

Kokomo, IN  
Tel: 765-864-8360  
Fax: 765-864-8387

#### Los Angeles

Mission Viejo, CA  
Tel: 949-462-9523  
Fax: 949-462-9608

#### San Jose

Mountain View, CA  
Tel: 650-215-1444  
Fax: 650-961-0286

#### Toronto

Mississauga, Ontario,  
Canada  
Tel: 905-673-0699  
Fax: 905-673-6509

### ASIA/PACIFIC

**Australia - Sydney**  
Tel: 61-2-9868-6733  
Fax: 61-2-9868-6755

**China - Beijing**  
Tel: 86-10-8528-2100  
Fax: 86-10-8528-2104

**China - Chengdu**  
Tel: 86-28-8676-6200  
Fax: 86-28-8676-6599

**China - Fuzhou**  
Tel: 86-591-8750-3506  
Fax: 86-591-8750-3521

**China - Hong Kong SAR**  
Tel: 852-2401-1200  
Fax: 852-2401-3431

**China - Qingdao**  
Tel: 86-532-8502-7355  
Fax: 86-532-8502-7205

**China - Shanghai**  
Tel: 86-21-5407-5533  
Fax: 86-21-5407-5066

**China - Shenyang**  
Tel: 86-24-2334-2829  
Fax: 86-24-2334-2393

**China - Shenzhen**  
Tel: 86-755-8203-2660  
Fax: 86-755-8203-1760

**China - Shunde**  
Tel: 86-757-2839-5507  
Fax: 86-757-2839-5571

**China - Wuhan**  
Tel: 86-27-5980-5300  
Fax: 86-27-5980-5118

**China - Xian**  
Tel: 86-29-8833-7250  
Fax: 86-29-8833-7256

### ASIA/PACIFIC

**India - Bangalore**  
Tel: 91-80-4182-8400  
Fax: 91-80-4182-8422

**India - New Delhi**  
Tel: 91-11-5160-8631  
Fax: 91-11-5160-8632

**India - Pune**  
Tel: 91-20-2566-1512  
Fax: 91-20-2566-1513

**Japan - Yokohama**  
Tel: 81-45-471- 6166  
Fax: 81-45-471-6122

**Korea - Gumi**  
Tel: 82-54-473-4301  
Fax: 82-54-473-4302

**Korea - Seoul**  
Tel: 82-2-554-7200  
Fax: 82-2-558-5932 or  
82-2-558-5934

**Malaysia - Penang**  
Tel: 60-4-646-8870  
Fax: 60-4-646-5086

**Philippines - Manila**  
Tel: 63-2-634-9065  
Fax: 63-2-634-9069

**Singapore**  
Tel: 65-6334-8870  
Fax: 65-6334-8850

**Taiwan - Hsin Chu**  
Tel: 886-3-572-9526  
Fax: 886-3-572-6459

**Taiwan - Kaohsiung**  
Tel: 886-7-536-4818  
Fax: 886-7-536-4803

**Taiwan - Taipei**  
Tel: 886-2-2500-6610  
Fax: 886-2-2508-0102

**Thailand - Bangkok**  
Tel: 66-2-694-1351  
Fax: 66-2-694-1350

### EUROPE

**Austria - Wels**  
Tel: 43-7242-2244-399  
Fax: 43-7242-2244-393

**Denmark - Copenhagen**  
Tel: 45-4450-2828  
Fax: 45-4485-2829

**France - Paris**  
Tel: 33-1-69-53-63-20  
Fax: 33-1-69-30-90-79

**Germany - Munich**  
Tel: 49-89-627-144-0  
Fax: 49-89-627-144-44

**Italy - Milan**  
Tel: 39-0331-742611  
Fax: 39-0331-466781

**Netherlands - Drunen**  
Tel: 31-416-690399  
Fax: 31-416-690340

**Spain - Madrid**  
Tel: 34-91-708-08-90  
Fax: 34-91-708-08-91

**UK - Wokingham**  
Tel: 44-118-921-5869  
Fax: 44-118-921-5820

02/16/06

Компания «Life Electronics» занимается поставками электронных компонентов импортного и отечественного производства от производителей и со складов крупных дистрибьюторов Европы, Америки и Азии.

С конца 2013 года компания активно расширяет линейку поставок компонентов по направлению коаксиальный кабель, кварцевые генераторы и конденсаторы (керамические, пленочные, электролитические), за счёт заключения дистрибьюторских договоров

Мы предлагаем:

- Конкурентоспособные цены и скидки постоянным клиентам.
- Специальные условия для постоянных клиентов.
- Подбор аналогов.
- Поставку компонентов в любых объемах, удовлетворяющих вашим потребностям.
- Приемлемые сроки поставки, возможна ускоренная поставка.
- Доставку товара в любую точку России и стран СНГ.
- Комплексную поставку.
- Работу по проектам и поставку образцов.
- Формирование склада под заказчика.
- Сертификаты соответствия на поставляемую продукцию (по желанию клиента).
- Тестирование поставляемой продукции.
- Поставку компонентов, требующих военную и космическую приемку.
- Входной контроль качества.
- Наличие сертификата ISO.

В составе нашей компании организован Конструкторский отдел, призванный помогать разработчикам, и инженерам.

Конструкторский отдел помогает осуществить:

- Регистрацию проекта у производителя компонентов.
- Техническую поддержку проекта.
- Защиту от снятия компонента с производства.
- Оценку стоимости проекта по компонентам.
- Изготовление тестовой платы монтаж и пусконаладочные работы.



Тел: +7 (812) 336 43 04 (многоканальный)

Email: [org@lifeelectronics.ru](mailto:org@lifeelectronics.ru)