



Eval Kit Manual

AS1383

Standard Board

AS1383-WL-xx_EK_ST

Table of Contents

1	Introduction	3
1.1	Kit Content	3
2	Getting Started	4
3	Hardware Description.....	4
4	Schematics, Layers and BOM	7
4.1	Schematic of AS1383 Evaluation Board	7
4.2	Layers of AS1383 Evaluation Board	8
4.3	BOM	10
5	Ordering & Contact Information	11
6	Copyrights & Disclaimer.....	12
7	Revision Information	13

1 Introduction

This document describes the AS1383 Evaluation Kit.

The AS1383 is a synchronous, high-efficiency DC-DC boost converter available as adjustable- and fixed voltage-version.

1.1 Kit Content

Figure 1: Kit Content

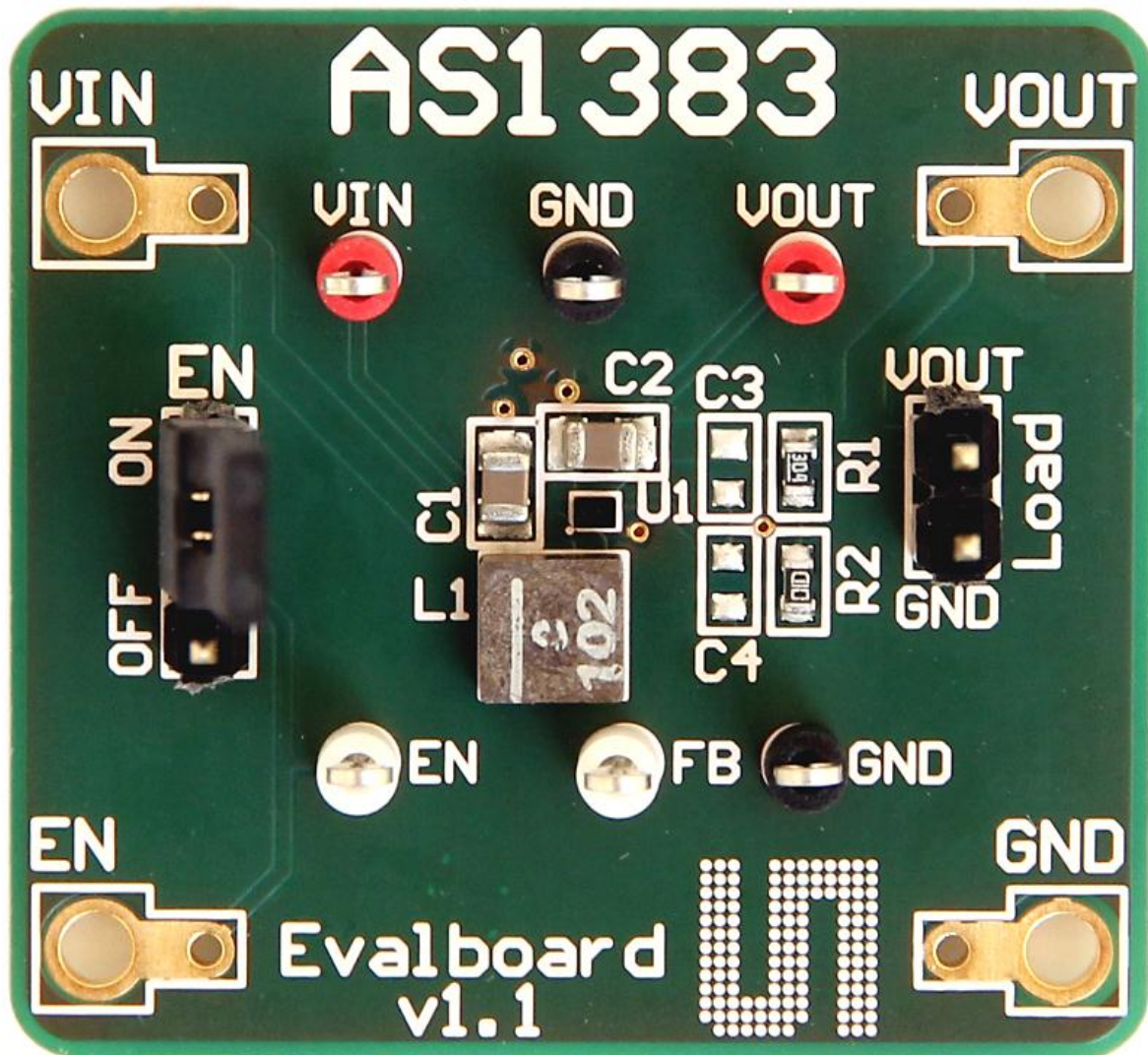

Item	Comment
AS1383 Evaluation Board	Synchronous, high efficiency DC-DC boost converter

2 Getting Started

Drive the AS1383 synchronous boost converter only with the recommended settings and values as described in the datasheet.

Please check www.ams.com for the latest version.

A detailed overview of AS1383 Evaluation Board is given in chapter 3, **Hardware Description**.

3 Hardware Description

The Evaluation Board has to be supplied via the connectors “VIN” (BU2) and “GND” in the range of 2.7V up to 5.5V.

For enabling the device jumper “EN” (J2) must be set to “on”, section F in **Figure 2**.

Please use the “VOUT”- (BU1) or “Load”- (J1) connector for connecting a load to Vout.



AS1383 supports output voltages between 2.7V and 5.0V and output loads up to 200mA.

The offered variants of AS1383 Evaluation Kit are stated under chapter 5, **Ordering & Contact Information**.

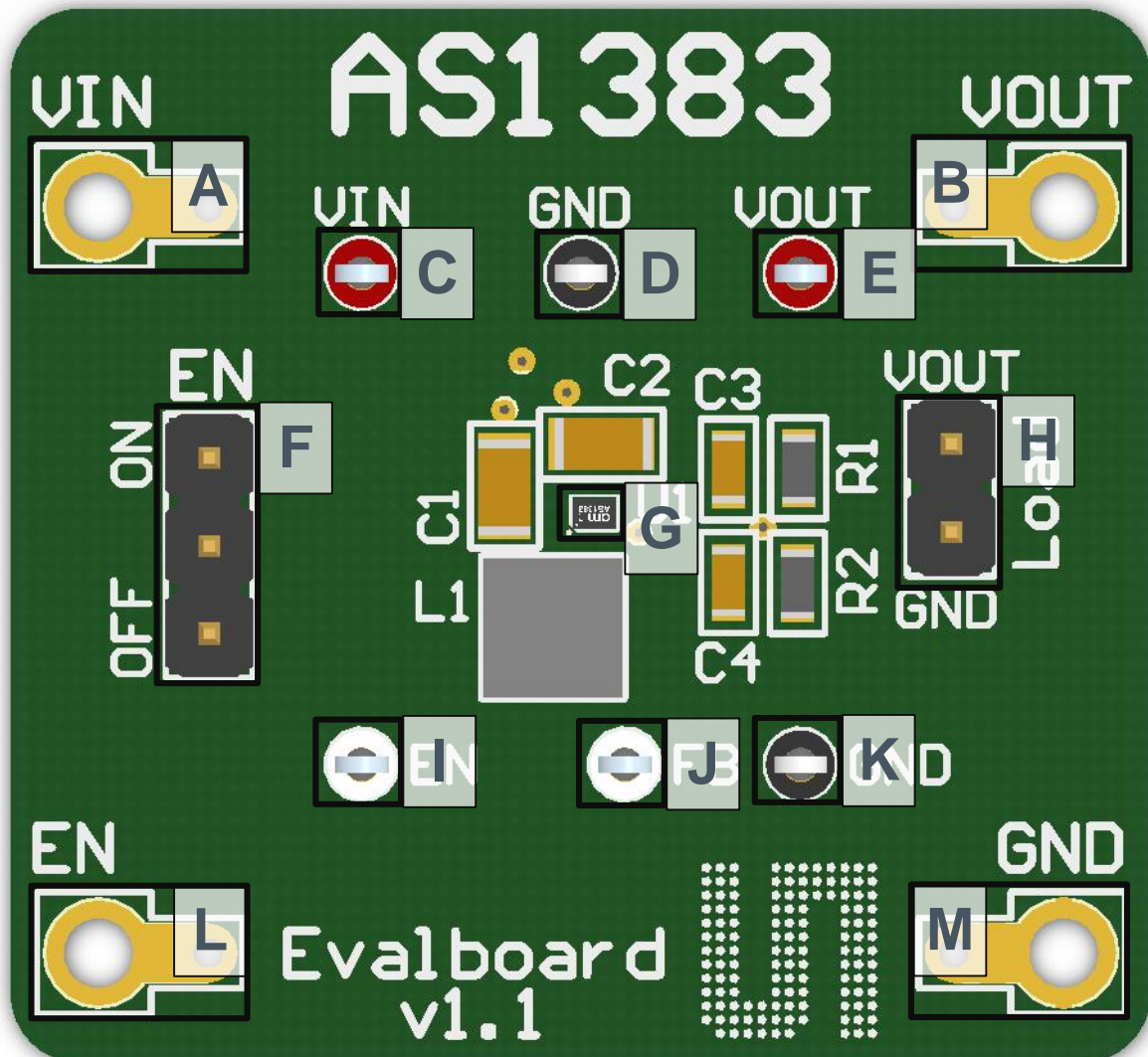
Figure 2: Evaluation Board Overview



Label	Name	Designator	Description	Info
A	VIN	BU2	Supply voltage	Voltage range from 2.7V to 5.5V Connect to the pos. terminal of the supply
B	VOUT	BU1	Output Voltage	Voltage range from 2.7 to 5.0V Designated for load connection
C	VIN	TP1	Supply voltage	measurement point
D	GND	TP4	Ground	measurement point
E	VOUT	TP2	Output Voltage	measurement point

Label	Name	Designator	Description	Info
F	EN	J2	Enable	 ON: AS1383 is enabled  OFF: AS1383 is put into shutdown mode No Jumper: Connect a valid enable signal to Enable Input (BU4) EN pin should not be left floating
G	AS1383	U1	6-pin WL-CSP	High-efficiency, synchronous boost converter running at a constant frequency of 3.5MHz
H	Load	J1	Load connector	Designated for load connection
I	EN	TP3	Enable	measurement point
J	FB	TP6	Feedback	measurement point
K	GND	TP5	Ground	measurement point
L	EN	BU4	Enable Input	A logic low on this pin puts the device in shutdown mode. "EN" Jumper (J2) must be removed when using this input to enable/disable the chip.
M	GND	BU3	Ground	Connect to the neg. terminal of the supply

4 Schematics, Layers and BOM

The AS1383 Evaluation Board is a 2-layer FR4 board.

Figure 3: AS1383 PCB Layer Stack up

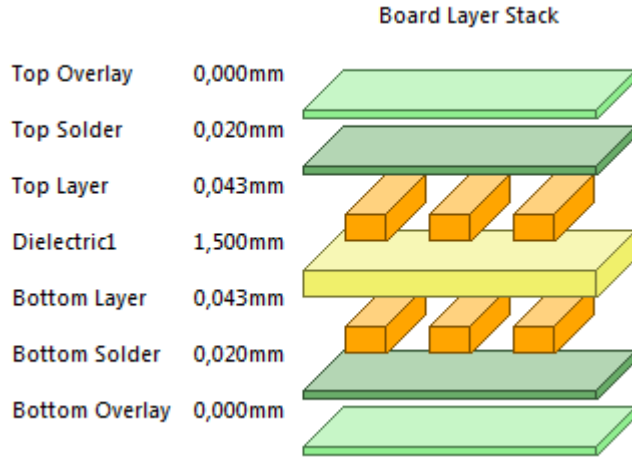

4.1 Schematic of AS1383 Evaluation Board

Figure 4: Schematic

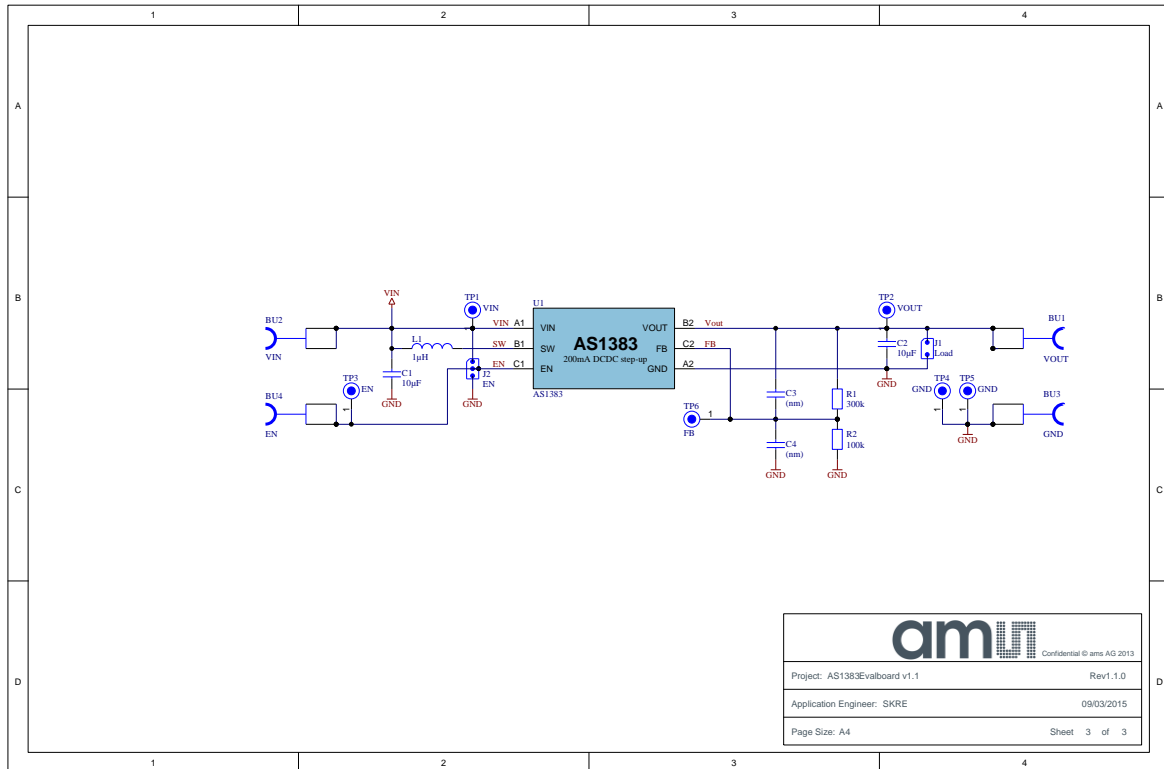

4.2 Layers of AS1383 Evaluation Board

Figure 5: Top Layer

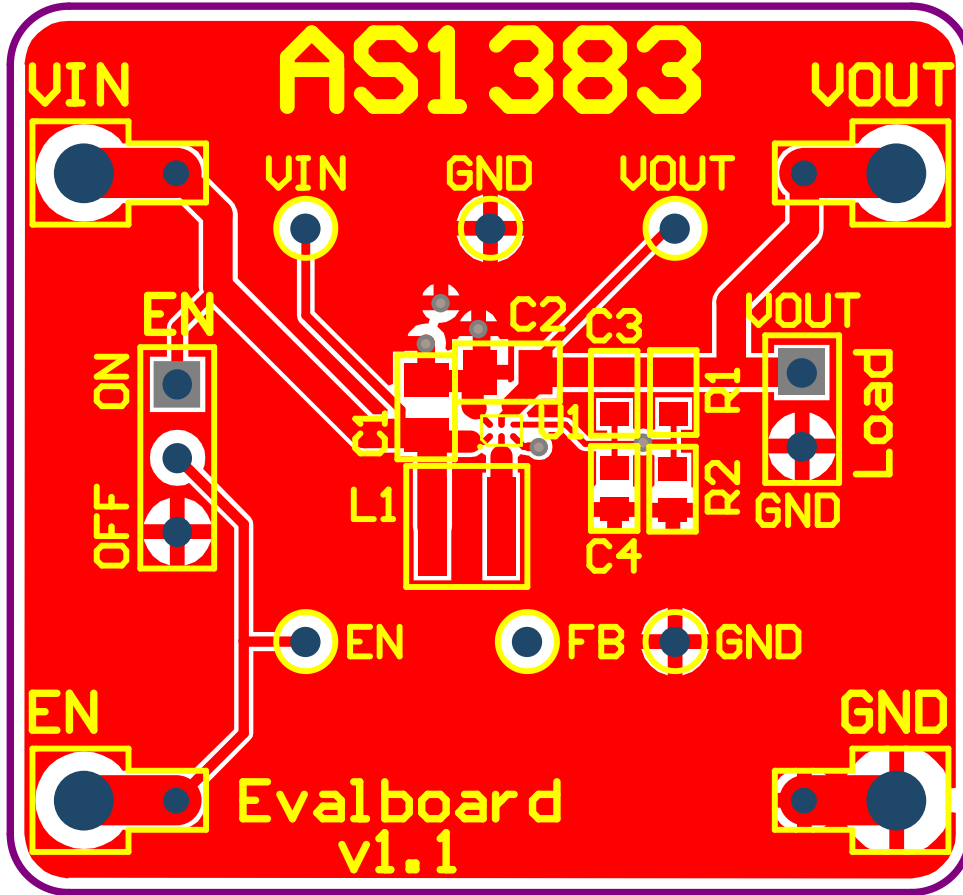
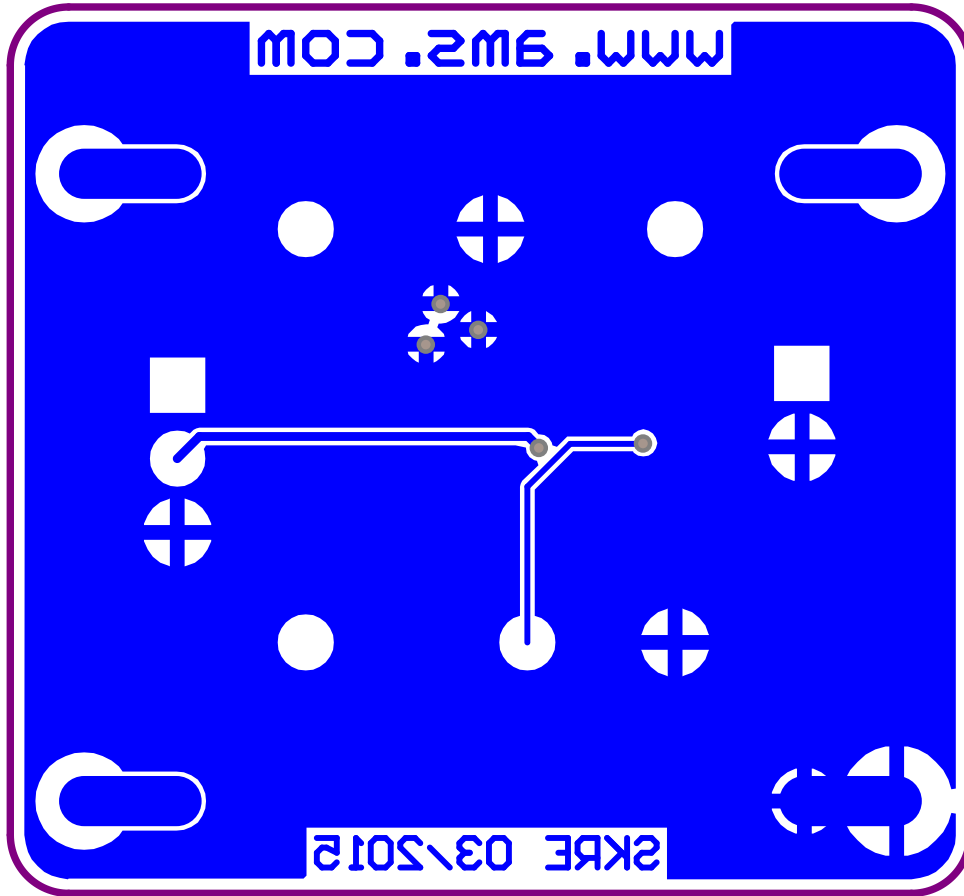

Figure 6: Bottom Layer



4.3 BOM

Figure 7: Bill of Material

Bill of Materials			ams			
Company: ams AG Application Engineer: SKRE Product Number: AS1383 ARS Project Name: - Boardtype & Version: Evalboard v1.1 Release Date: 09/03/2015 Revision: Rev1.1.0						
#	Designator	Comment	Component Description	Manufacturer	Manufacturer Part Number	Quantity
	C1, C2	10µF	Murata 10µF 10V X5R,SMD 0805	Murata	GRM219R61A106ME47	2
	J1	Load	TE CONNECTIVITY / AMP - 826629-2- HEADER, 1ROW, 2POS	TE CONNECTIVITY / AMP	826629-2	1
	J2	EN	TE CONNECTIVITY / AMP - 826629-3- HEADER, 1ROW, 3POS	TE CONNECTIVITY / AMP	826629-3	1
	L1	1µH	COILCRAFT - XFL4020-102MEC - POWER INDUCTOR 1UH, 11A, 20%, 64MHZ	COILCRAFT	XFL4020-102MEC	1
	R1	300k	RES SMD 300K OHM 1% 1/10W 0603	Vishay Dale	CRCW0603300KFKEA	1
	R2	100k	RES 100K OHM 1/10W 1% 0603 SMD	Vishay Dale	CRCW0603100KFKEA	1
	TP1, TP2	VIN, VOUT	VERO - 20-313137 - RED BEAD TERMINAL ASSY FOR 1.02mm hole	VERO	20-313137	2
	TP3, TP6	EN, FB	VERO - 20-313139 - WHITE BEAD TERMINAL ASSY FOR 1.02mm hole	VERO	20-313139	2
	TP4, TP5	GND	VERO - 20-2137 - BLACK BEAD TERMINAL ASSY FOR 1.02mm hole	VERO	20-2137	2
	U1	AS1383		ams		1
Approved by			Notes			14

Assembled components on Evalboard may vary from BOM

5 Ordering & Contact Information

Ordering Code	Description
AS1383-WL-xx_EK_ST	AS1383 Eval Kit Standard Board
AS1383-WL-AD_EK_ST	AS1383 Adjustable Eval Kit Standard Board

Buy our products or get free samples online at:

www.ams.com/ICdirect

Technical Support is available at:

www.ams.com/Technical-Support

Provide feedback about this document at:

www.ams.com/Document-Feedback

For further information and requests, e-mail us at:

ams_sales@ams.com

For sales offices, distributors and representatives, please visit:

www.ams.com/contact

Headquarters

ams AG

Tobelbaderstrasse 30

8141 Unterpemstaetten

Austria, Europe

Tel: +43 (0) 3136 500 0

Website: www.ams.com

6 Copyrights & Disclaimer

Copyright ams AG, Tobelbader Strasse 30, 8141 Unterpremstaetten, Austria-Europe. Trademarks Registered. All rights reserved. The material herein may not be reproduced, adapted, merged, translated, stored, or used without the prior written consent of the copyright owner.

Demo Kits, Evaluation Kits and Reference Designs are provided to recipient on an “as is” basis for demonstration and evaluation purposes only and are not considered to be finished end-products intended and fit for general consumer use, commercial applications and applications with special requirements such as but not limited to medical equipment or automotive applications. Demo Kits, Evaluation Kits and Reference Designs have not been tested for compliance with electromagnetic compatibility (EMC) standards and directives, unless otherwise specified. Demo Kits, Evaluation Kits and Reference Designs shall be used by qualified personnel only.

ams AG reserves the right to change functionality and price of Demo Kits, Evaluation Kits and Reference Designs at any time and without notice.

Any express or implied warranties, including, but not limited to the implied warranties of merchantability and fitness for a particular purpose are disclaimed. Any claims and demands and any direct, indirect, incidental, special, exemplary or consequential damages arising from the inadequacy of the provided Demo Kits, Evaluation Kits and Reference Designs or incurred losses of any kind (e.g. loss of use, data or profits or business interruption however caused) as a consequence of their use are excluded.

ams AG shall not be liable to recipient or any third party for any damages, including but not limited to personal injury, property damage, loss of profits, loss of use, interruption of business or indirect, special, incidental or consequential damages, of any kind, in connection with or arising out of the furnishing, performance or use of the technical data herein. No obligation or liability to recipient or any third party shall arise or flow out of ams AG rendering of technical or other services.

7 Revision Information

Initial release 1-00

Компания «Life Electronics» занимается поставками электронных компонентов импортного и отечественного производства от производителей и со складов крупных дистрибьюторов Европы, Америки и Азии.

С конца 2013 года компания активно расширяет линейку поставок компонентов по направлению коаксиальный кабель, кварцевые генераторы и конденсаторы (керамические, пленочные, электролитические), за счёт заключения дистрибьюторских договоров

Мы предлагаем:

- Конкурентоспособные цены и скидки постоянным клиентам.
- Специальные условия для постоянных клиентов.
- Подбор аналогов.
- Поставку компонентов в любых объемах, удовлетворяющих вашим потребностям.
- Приемлемые сроки поставки, возможна ускоренная поставка.
- Доставку товара в любую точку России и стран СНГ.
- Комплексную поставку.
- Работу по проектам и поставку образцов.
- Формирование склада под заказчика.
- Сертификаты соответствия на поставляемую продукцию (по желанию клиента).
- Тестирование поставляемой продукции.
- Поставку компонентов, требующих военную и космическую приемку.
- Входной контроль качества.
- Наличие сертификата ISO.

В составе нашей компании организован Конструкторский отдел, призванный помогать разработчикам, и инженерам.

Конструкторский отдел помогает осуществить:

- Регистрацию проекта у производителя компонентов.
- Техническую поддержку проекта.
- Защиту от снятия компонента с производства.
- Оценку стоимости проекта по компонентам.
- Изготовление тестовой платы монтаж и пусконаладочные работы.



Тел: +7 (812) 336 43 04 (многоканальный)

Email: org@lifeelectronics.ru