



## Main

Range of product	Harmony XAC
Product or component type	Pendant control station
Device short name	XACB

## Complementary

Control station type	Double insulated
Enclosure material	Glass reinforced polyester
Electrical circuit type	Power circuit
Enclosure type	Complete ready for use
Control station application	Control of single speed hoist motor
Control station composition	2 push-buttons
Control button type	First pushbutton raise, slow Second pushbutton lower, slow
Product compatibility	XESB2011 for reversing operation
Mechanical interlocking	Without mechanical interlock
Control station colour	Yellow
Connections - terminals	Screw clamp terminals 1 x 2.5 mm <sup>2</sup> with or without cable end Screw clamp terminals 2 x 1.5 mm <sup>2</sup> with or without cable end
Standards	EN/IEC 60204-32 EN/IEC 60947-5-1 CSA C22.2 No 14
Product certifications	CSA 300V type 4
Protective treatment	TH
Ambient air temperature for operation	-13...158 °F (-25...70 °C)
Ambient air temperature for storage	-40...158 °F (-40...70 °C)
Vibration resistance	15 gn 10...500 Hz IEC 60068-2-6
Shock resistance	100 gn IEC 60068-2-27
Overvoltage category	Class II
IP degree of protection	IP65 IEC 60529
IK degree of protection	IK08 EN 50102
Mechanical durability	1000000 cycles
Cable entry	Rubber sleeve with stepped entry 10...22 mm
Contact code designation	A600 AC-15 240 V 3 A IEC 60947-5-1 appendix A Q600 DC-13 250 V 0.27 A IEC 60947-5-1 appendix A
[Ithe] conventional enclosed thermal current	10 A
[Ui] rated insulation voltage	500 V 3 IEC 60947-1
[Uimp] rated impulse withstand voltage	6 kV IEC 60947-1
Contact operation	Snap action
Resistance across terminals	<= 25 MOhm
Operating force	7 N push-button
Short-circuit protection	10 A fuse protection cartridge gG
Rated operational power in VA	100 VA AC-15 1000000 cycles 60 cyc/mn 48 V 50/60 Hz 0.5 inductive 450 VA AC-15 1000000 cycles 60 cyc/mn 127 V 50/60 Hz 0.5 inductive 50 VA AC-15 1000000 cycles 60 cyc/mn 24 V 50/60 Hz 0.5 inductive 750 VA AC-15 1000000 cycles 60 cyc/mn 230 V 50/60 Hz 0.5 inductive

The information provided in this documentation contains general descriptions and/or technical characteristics of the products contained herein. This documentation is not intended as a substitute for and is not to be used for determining suitability or reliability of these products for specific user applications. It is the duty of any such user or integrator to perform the appropriate and complete risk analysis, evaluation and testing of the products with respect to the relevant specific application or use thereof. Neither Schneider Electric Industries SAS nor any of its affiliates or subsidiaries shall be responsible or liable for misuse of the information contained herein.

Rated operational power in W	140 W DC-13 1000000 cycles 60 cyc/mn 24 V 0.5 inductive IEC 60947-5-1 appendix C 140 W DC-13 1000000 cycles 60 cyc/mn 48 V 0.5 inductive IEC 60947-5-1 appendix C 95 W DC-13 1000000 cycles 60 cyc/mn 120 V 0.5 inductive IEC 60947-5-1 appendix C
Terminals description ISO n°1	(1-2-3-4)OC
Terminal identifier	(11-12)NC (13-14)NO
Product weight	1.87 lb(US) (0.85 kg)

## Environment

### Offer Sustainability

WARNING: This product can expose you to chemicals including:	WARNING: This product can expose you to chemicals including:
Nickel compounds, which is known to the State of California to cause cancer, and	Nickel compounds, which is known to the State of California to cause cancer, and
Di-isodecyl phthalate (DIDP), which is known to the State of California to cause birth defects or other reproductive harm.	Di-isodecyl phthalate (DIDP), which is known to the State of California to cause birth defects or other reproductive harm.
For more information go to <a href="http://www.p65warnings.ca.gov">www.p65warnings.ca.gov</a>	For more information go to <a href="http://www.p65warnings.ca.gov">www.p65warnings.ca.gov</a>

### Contractual warranty

Warranty period	18 months
-----------------	-----------

## Dimensions

Below drawing shows a product with 6 cut-outs. Select the number of cut-outs according to the product characteristics in order to get b, b1 and c dimensions.

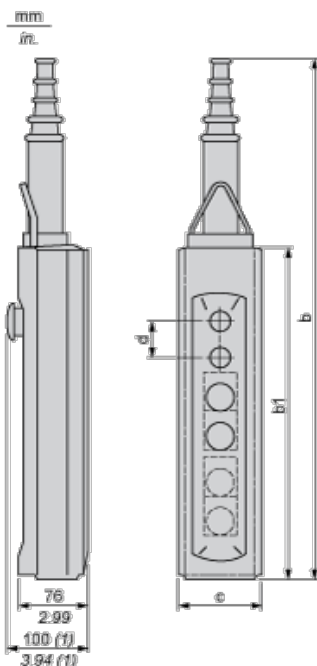

(1) With mushroom head operator

#### Dimensions in mm

Number of cut-outs	2	4	6	8	12
b	409	499	589	679	679
b1	220	310	400	490	490
c	98	98	98	98	98
d	40	40	40	40	30

Dimensions in in.

Number of cut-outs	2	4	6	8	12
b	16.10	19.64	23.19	26.73	26.73
b1	8.66	12.20	15.75	19.29	19.29
c	3.86	3.86	3.86	3.86	3.86
d	1.57	1.57	1.57	1.57	1.18

Protective cable sleeves

$\frac{\text{mm}}{\text{in.}}$

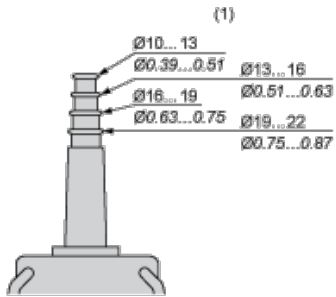

(1) Internal  $\varnothing$

Компания «Life Electronics» занимается поставками электронных компонентов импортного и отечественного производства от производителей и со складов крупных дистрибьюторов Европы, Америки и Азии.

С конца 2013 года компания активно расширяет линейку поставок компонентов по направлению коаксиальный кабель, кварцевые генераторы и конденсаторы (керамические, пленочные, электролитические), за счёт заключения дистрибьюторских договоров

Мы предлагаем:

- Конкуренспособные цены и скидки постоянным клиентам.
- Специальные условия для постоянных клиентов.
- Подбор аналогов.
- Поставку компонентов в любых объемах, удовлетворяющих вашим потребностям.
- Приемлемые сроки поставки, возможна ускоренная поставка.
- Доставку товара в любую точку России и стран СНГ.
- Комплексную поставку.
- Работу по проектам и поставку образцов.
- Формирование склада под заказчика.
- Сертификаты соответствия на поставляемую продукцию (по желанию клиента).
- Тестирование поставляемой продукции.
- Поставку компонентов, требующих военную и космическую приемку.
- Входной контроль качества.
- Наличие сертификата ISO.

В составе нашей компании организован Конструкторский отдел, призванный помогать разработчикам, и инженерам.

Конструкторский отдел помогает осуществить:

- Регистрацию проекта у производителя компонентов.
- Техническую поддержку проекта.
- Защиту от снятия компонента с производства.
- Оценку стоимости проекта по компонентам.
- Изготовление тестовой платы монтаж и пусконаладочные работы.



Тел: +7 (812) 336 43 04 (многоканальный)

Email: [org@lifeelectronics.ru](mailto:org@lifeelectronics.ru)