

Features

- 64 kbit I²C EEPROM-compatible non-volatile serial memory
- Single supply voltage: 1.65V - 2.2V
- Small form factor
- Low power consumption
 - Low energy 4-byte write: 200nJ
 - Active write: 1.0 mA
 - Active read current: 0.2 mA
 - Typical standby current: 15 μ A
- Fast write
 - 4-byte write: 40 μ s
 - 32-byte page write: 0.3 ms
- Flexible byte and page write modes: 1 to 32 bytes
- Random and sequential read modes
- 128-byte one-time programmable (OTP) security register
 - 64 bytes factory programmed with unique identifier
 - 64 bytes user programmable
- Software write protect
 - All, $\frac{1}{2}$, or $\frac{1}{4}$ of the array can be protected
- 2-wire I²C interface
 - 100 kHz
 - 400 kHz
 - 1 MHz
- RoHS-compliant and halogen-free packaging
- Data retention: 10 years
- Endurance: 10,000 write cycles
- Unlimited read cycles
- Packaging
 - 4-ball WLCSP
 - DWF - Die in Wafer Form

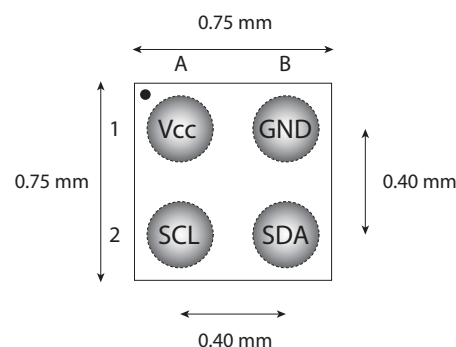

1. Block Diagram

Figure 1-1. Block Diagram

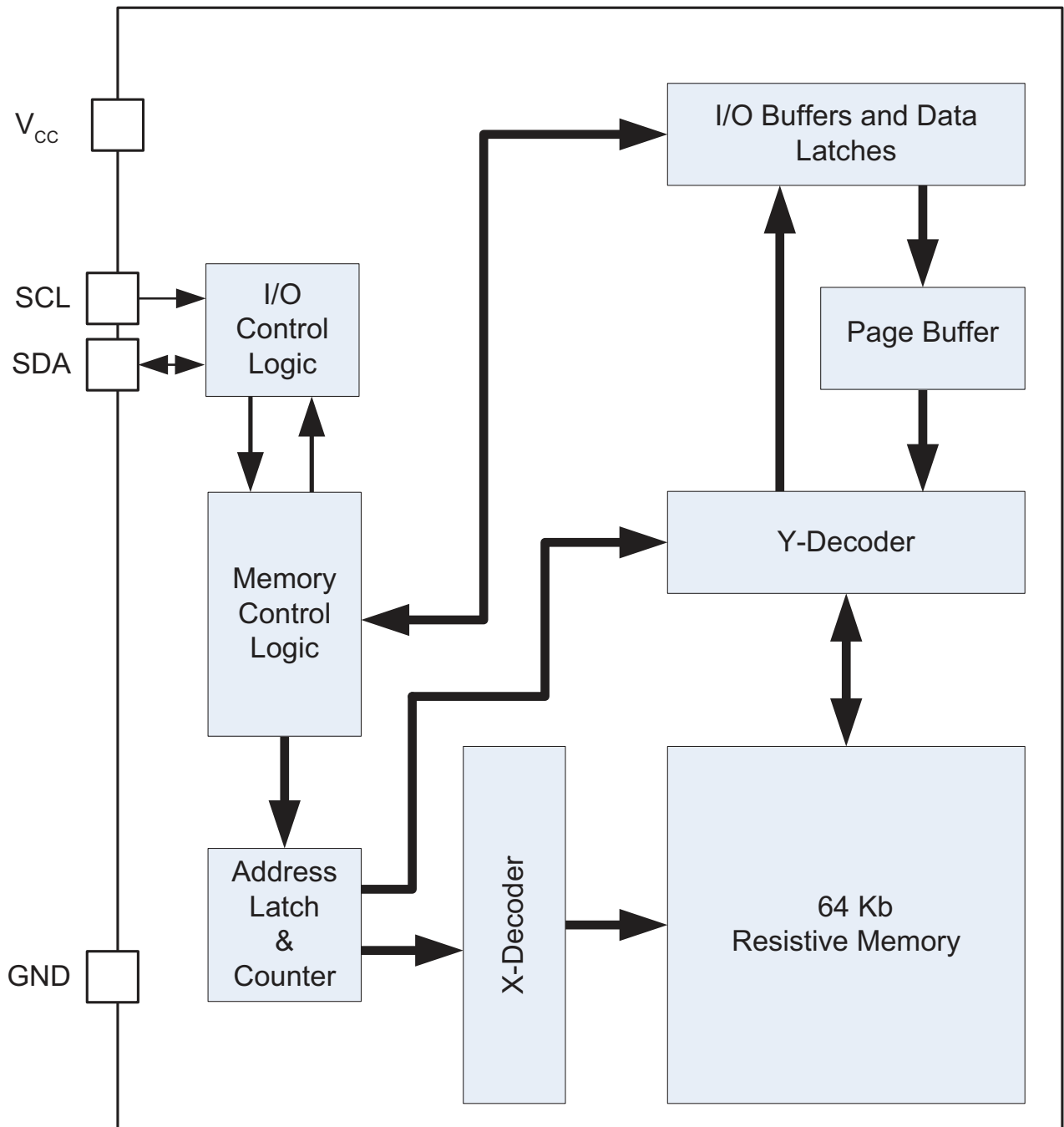

2. Pin Descriptions

Table 2-1. Pin Descriptions

Symbol	Pin #	Name/Function	Description
GND	B1	Ground	Ground pin.
SDA	B2	Serial Data	Bidirectional pin used to transfer addresses and data into and data out of the device. It is an open-drain terminal, and therefore requires a pull-up resistor to VCC. Typical pull-up resistors are: 10K Ω for 100KHz, and 2K Ω for 400KHz and 1MHz. For normal data transfer, SDA is allowed to change only during SCL low. Changes during SCL high are reserved for indicating the START and STOP conditions.
SCL	A2	Serial Clock	This input is used to synchronize the data transfer from and to the device. SCL is an input only, since it is a slave-only device.
Vcc	A1	Power	Power supply pin

2.1 Pin Out Diagram

2.1.1 Pinouts

WLCSP (Top View, balls not visible)

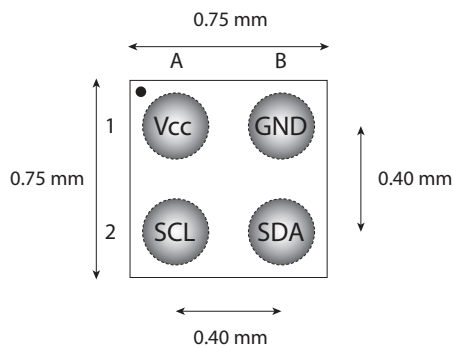

3. I²C Bus Protocol

The I²C bus is a 2-wire serial bus architecture with a clock pin (SCL) for synchronization, and a data pin (SDA) for data transfer. The SDA data pin is bi-directional. The SCL clock pin is an input only because the device is slave-only. The SCL and SDA pins are both externally connected to a positive supply voltage via a current source or pull-up resistor. When the bus is free, both lines are high. The output stages of devices connected to the bus must have an open drain or open collector to perform a wired-AND function. Data on the I²C bus can be transferred at rates of up to 1 Mbit/s. The number of interfaces that may be connected to the bus is solely dependent on the bus capacitance limit of 400pF.

The data on the SDA line must be stable during the high period of the clock. The high or low state of the data line can only change when the clock signal on the SCL line is low (see Figure 3-1).

Figure 3-1. Bit Transfer on the I²C bus

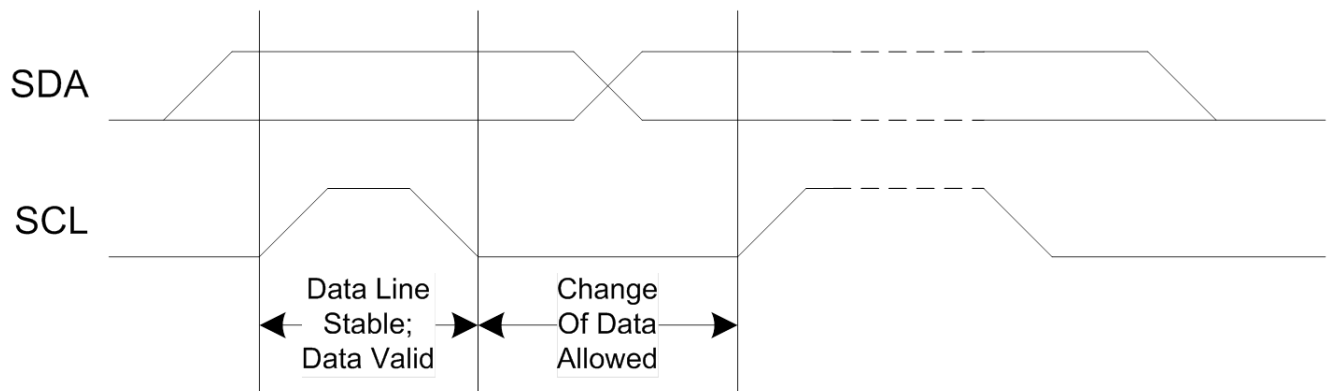

A high-to-low transition on the SDA line while SCL is high indicates a START condition. A low-to-high transition on the SDA line while SCL is high defines a STOP condition.

START and STOP conditions are always generated by the master. The bus is considered to be busy after the START condition. The bus is considered to be free again a certain time after the STOP condition (see Figure 3-2).

Figure 3-2. START and STOP conditions



Every byte put on the SDA line must be 8 bits long. The number of bytes that can be transmitted per transfer is unrestricted. Each byte must be followed by an acknowledge bit; therefore, the number of clock cycles to transfer one byte is nine. Data is transferred with the most significant bit (MSB) first.

3.1 I²C Master and Slave Configuration

The RM24C64AF has a two-pin industry-standard I²C interface. It is configured as a slave-only device and therefore does not generate a clock. 8-pin I²C devices are usually assigned an address by connecting the external E0, E1 and E2 enable pins in the configuration shown in Figure 3-3. This allows up to eight devices can be connected onto an I²C Interface bus controlled by an I²C master device, such as a micro-controller. The RM24C64AF lacks the external enable pins, but comes in two predefined configurations, RM24C64AF-0 and RM24C64AF-7, which allows it to take the position as Memory Device #0 or Memory Device #7 on the I²C bus.

Figure 3-3. Connection between I²C Master and Slaves

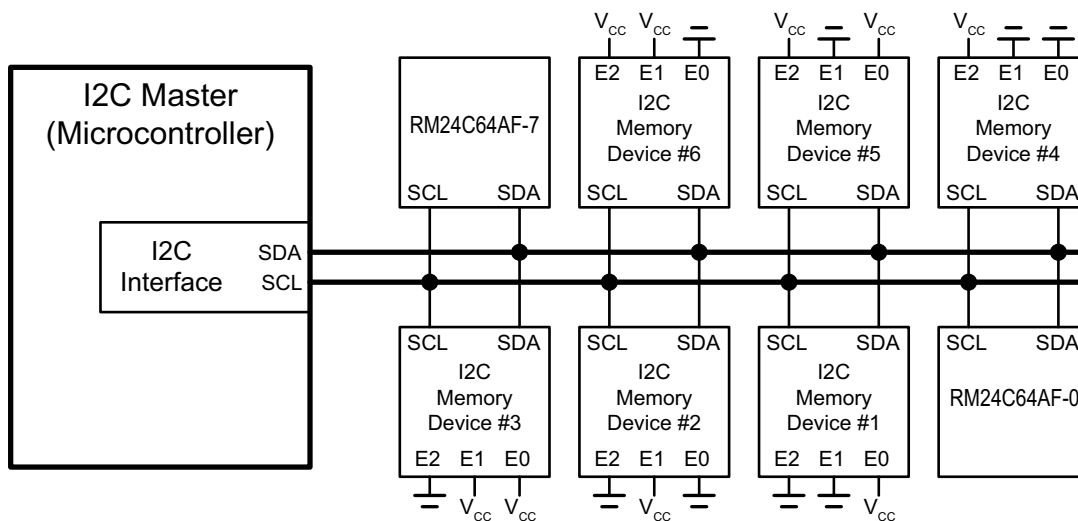

4. Device Timing

4.1 Power-Up/Power-Down Voltage and Timing Requirements

As the device initializes, there is a transient current demand. While the device is being powered-up, the internal Power-On-Reset (POR) circuitry keeps the device in a reset mode until the supply voltage rises above the minimum V_{CC} . During this time, all operations are disabled and the device does not respond to any commands.

The first operation to the device after power-up cannot be started until the supply voltage reaches the minimum V_{CC} level and an internal device delay has elapsed. This delay is a maximum time of t_{PUD} . After the t_{PUD} time, the device enters standby mode. For the case of power-down then power-up operation, or if a power interruption occurs, the V_{CC} of the device must be maintained below V_{PWD} for at least the minimum specified T_{PWD} time. This is to ensure the device resets properly after a power interruption.

Table 4-1. Voltage and Timing Requirements for Power-Up / Power-Down

Symbol	Parameter	Min	Max	Units
t_{PWD}	Minimum low time during brown-out.	10		ms
V_{PWD}	Maximum voltage during brown-out.		0.2	V
t_{VR}	V_{CC} rise time.		200	ms
t_{PUD}	Power-up device delay before access is allowed.		250	μ s

Figure 4-1. Bus Timing Data

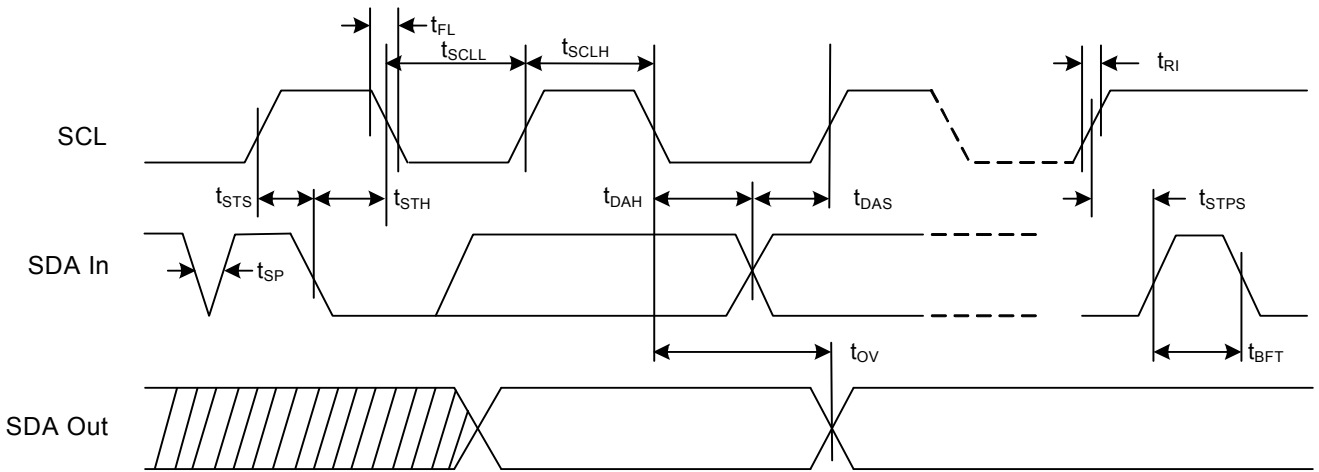
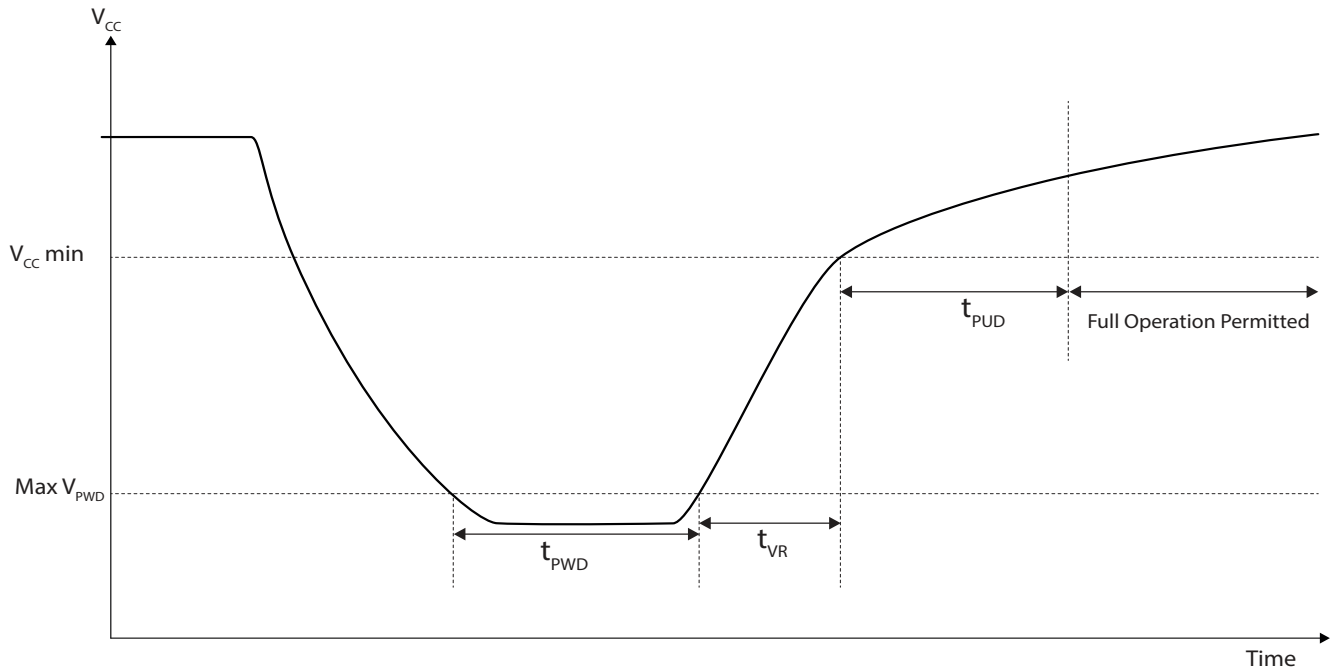

Figure 4-2. Power-Up Timing



5. Device Addressing

The first byte sent from the master device to the EEPROM following the START condition is the control byte (See Figure 5-1). The first four bits of the control byte indicate the control code. When accessing the EEPROM memory area, the control code is “1010” both for read and for write operations. When accessing the OTP Security Registers, the control code is “1011” both for read and for write operations.

The next three bits of the control byte are the enable bits (E2, E1 and E0), which are “000” for an RM24C64AF-0 device and “111” for an RM24C64AF-7 device. The E0, E1 and E2 bits sent in the control byte must correspond to the internal E0, E1 and E2 bits for a device to be selected. In effect, the E0, E1 and E2 bits in the control register act as the three MSB bits of a word address. These three bits allow the use of up to eight I2C devices on the same bus, of which one can be an RM24C64AF-0 device and one can be an RM24C64AF-7 device. The last bit of the control byte (R/\bar{W}) defines the

operation to be performed, read or write. If set to a logic one, a read operation is selected. If set to a logic zero, a write operation is selected.

Figure 5-1. Control Byte, EEPROM Access

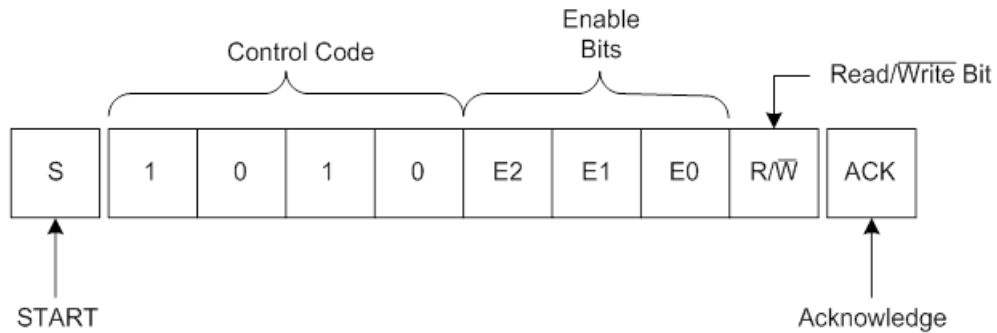
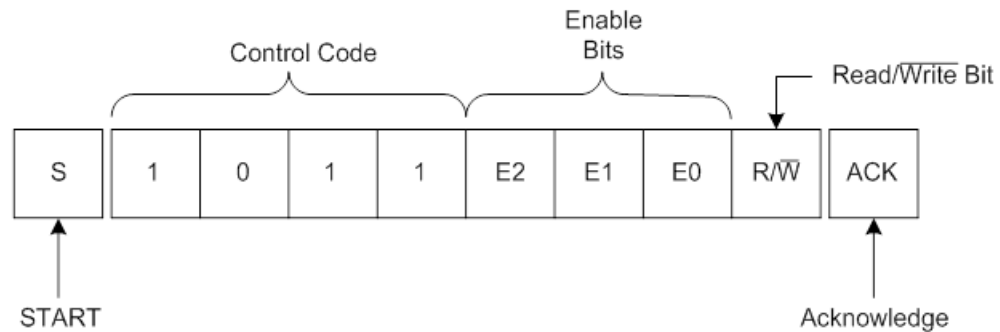

Figure 5-2. Control Byte, OTP Security Register and WP Register Access



Upon receiving the correct control code, the chip enable bits, and the $\overline{R/W}$ bit, the device performs an acknowledge by pulling the SDA line low during the 9th clock pulse. As stated above, the device is now set for either a read or a write operation by the $\overline{R/W}$ bit.

After the device acknowledges the control byte, two additional bytes are sent by the master to the slave. These bytes define the target address of the byte in the device to be written. The bit assignment for the address is shown in Figure 5-3. It should be noted that not all the address bits are used. For the RM24C64AF, only address A0 to A12 are used; the rest are don't cares and must be set to "0".

Figure 5-3. Address Sequence Bit Assignments

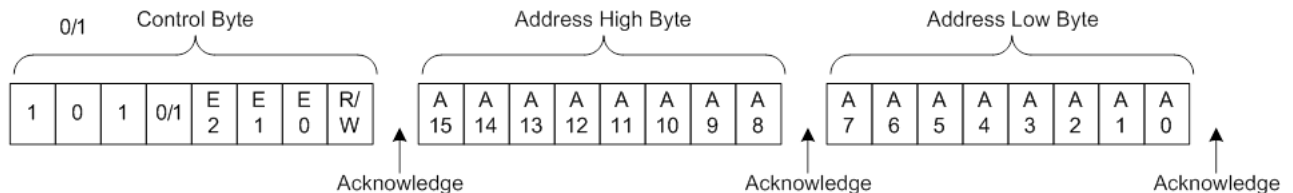

The device acknowledges each byte of data that is received by pulling the SDA line low during the 9th clock pulse. If the device does not provide an acknowledge, it has not received the data, in which case the entire sequence, starting with the control byte, must be resent.

6. Byte Write Operation

If the R/\overline{W} bit in the control byte is set to zero, the device enters write mode, where the following sequence of events occurs.

- Once the control byte is received, the device sends an acknowledge. It is then ready to receive the address high byte (see Figure 6-1).
- After receiving the address high byte, the device sends an acknowledge and is ready to receive the address low byte.
- After receiving the address low byte, the device acknowledges and then writes the address (expressed by the high and low address bytes) into its address pointer.
- The device is then ready to receive a byte of data to be written into the addressed memory location.
- After the device receives the data, it performs an acknowledge.
- After the master has received the last acknowledge (after the data byte) the master should send a STOP condition. The STOP condition initiates the internal write cycle in the device. If the master does not send a STOP, the device does not write the data into the addressed memory location.

While the device is in the write cycle it will not generate an acknowledge signal. Meanwhile, the master can poll the device to determine when the write cycle is complete by sending it a control byte and looking for an acknowledge. Once the write cycle has completed, the device acknowledges the control byte sent to it.

If the byte written is the last byte in a 32-byte page, the address wraps around to the beginning of the same page. For instance, if the byte is written to address 01FFh, the incremented address will be 01E0h. If the byte is written to address 073Fh, the incremented address will be 0720h.

Note that even though the device supports single byte operation, it operates internally on 4-byte words. The write time for a single byte is therefore the same as for a 4-byte word.

Figure 6-1. Byte Write Cycle

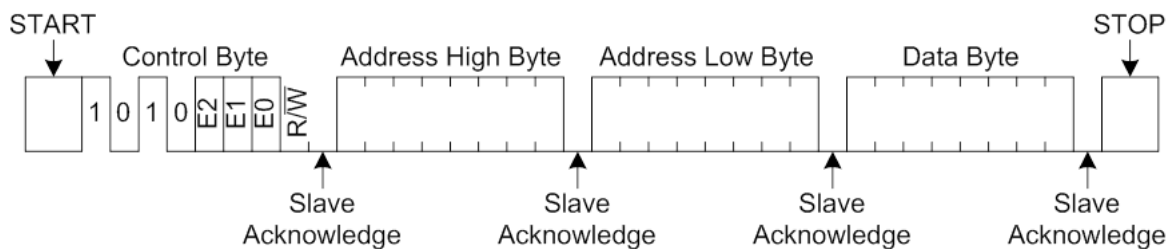

7. Page Write Operation

Table 7-1. Density and Page Size

Product	Density	Page Size (byte)
RM24C64AF	64 Kbit	32

During a page write cycle, a page with up to 32 bytes of data can be written in one continuous write command. The page write starts in the same manner as the byte write. In a page write, after the acknowledge following the first data byte, the master does not send a STOP, but continues to send additional data bytes (see Figure 7-1). At the end of the number of bytes to be written, the master sends a STOP command. Once the STOP command is sent, the device writes all the data bytes into memory, starting at the address location given in the address bytes.

If the master should transmit more than 32 bytes prior to generating the STOP command, the internal 32-byte data buffer in the device wraps around and the first data bytes transmitted are overwritten.

The internal address pointer is not increment beyond a page boundary but instead wraps around to the first byte of the addressed page.

As with the byte write cycle, once the STOP command is received the device enters a write cycle. During the write cycle, the device does not generate an acknowledge signal. Meanwhile, the master can poll the device to determine when the write cycle is complete by sending it a control byte and looking for an acknowledge. Once the write cycle has completed, the device acknowledges the control byte sent to it.

During the page write cycle, the first byte in the data byte buffer is written in the address location indicated by the address bytes transmitted to the device. Each successive data byte is written in successive address locations.

Note that the page write operation is internally executed by sequentially writing the words in the page buffer. Therefore the page write time can be estimated as byte write time multiplied by the number of words to be written.

Figure 7-1. Page Write Cycle Bus Transfer

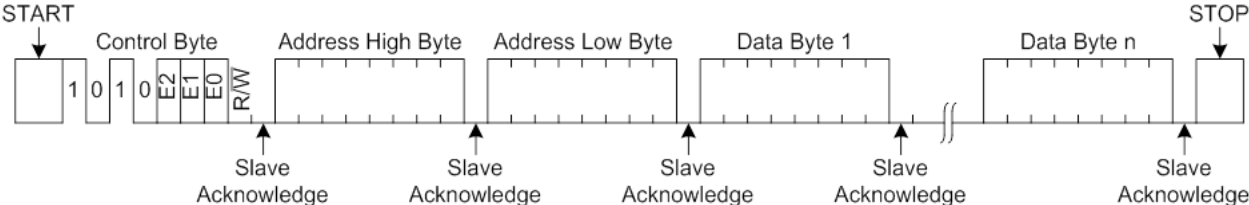
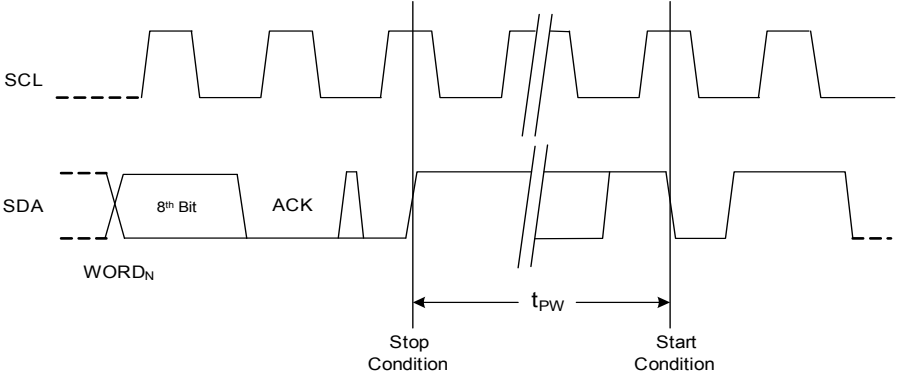

Figure 7-2. Page Write Cycle Timing



8. Write Protection

The RM24C64 has a software write protect feature which prevents accidental writes. By writing specific values in register located addresses (see below) the memory array can be write-protected in blocks (as follows):

- Top quarter of memory array
- Top half of memory array
- All of memory array
- Write Protection Register (only bits 3/2 are implemented), these two bits are non-volatile
- The bits 3/2 are named BP1 and BP0 and provide the protection for the memory and allow part or the whole memory area to be write protected
- Read/Write to the WP register is done using the “1011” command with address A[15:0] = 16'h0401

Table 8-1. BP1:BP0 Encoding of 64K Device

BP1	BP0	Protected Region	Protected Address (128 kbit)	Protected Area Size (128 kbit)
0	0	None	None	0
0	1	Top 1/4	1800 - 1FFF	2 kBytes
1	0	Top 1/2	1000 - 1FFF	4 kBytes
1	1	All	0 - 1FFF	All

The Adesto RM24C64AF uses a 1-byte Write Protect (WP) Register. The non-volatile bits BP1 and BP0 are found in the WP Register. The WP Register format is shown in Table 8-2. The WP Register bit definitions are shown in Table 8-3.

Note: The first time a new device is programmed, the non-volatile Block Protection bits (BP0 and BP1) should be written to 0 before writing data to the EEPROM memory.

Table 8-2. Write Protect Register Format

Bit7	Bit6	Bit5	Bit4	Bit3	Bit2	Bit1	Bit0
0	0	0	0	BP1	BP0	0	0

Table 8-3. Write Protect Bit Definitions

Bit	Name	Description	R/W	Non-Volatile Bit
0	N/A	Reserved. Read as "0"	N/A	No
1	N/A	Reserved. Read as "0"	N/A	No
2	BP0	Block Protection Bits. "0" indicates the specific blocks are not protected. "1" indicates that the specific blocks are protected.	R/W	Yes
3	BP1			
4	N/A	Reserved. Read as "0"	N/A	No
5	N/A	Reserved. Read as "0"	N/A	No
6	N/A	Reserved. Read as "0"	N/A	No
7	N/A	Reserved. Read as "0"	N/A	No

The Write Protect (WP) register write operation is similar to the byte write operation, except that the control code (the first four bits of the command byte) is "1011" instead of "1010". The address of the WP register is 0401h.

If the $\overline{R/W}$ bit in the control byte is set to zero, the device enters write mode and the following events occur.

- Once the control byte is received, the device performs an acknowledge. It is then ready to receive the address high byte, 04h (see Figure 8-1).
- After receiving the address high byte, the device acknowledges and is ready to receive the address low byte, 01h.
- After receiving the address low byte, the device acknowledges and then writes the address (0401h) into its address pointer. The device is then ready to receive a byte of data to be written into the WP Register.
- After the device receives the data, it performs an acknowledge.
- After the master has received the last acknowledge (after the data byte), the master should send a STOP condition. The STOP condition initiates the internal write cycle in the device. If the master does not send a STOP, the device does not write the data into the WP Register.

Figure 8-1. Write Protect Register Write Cycle

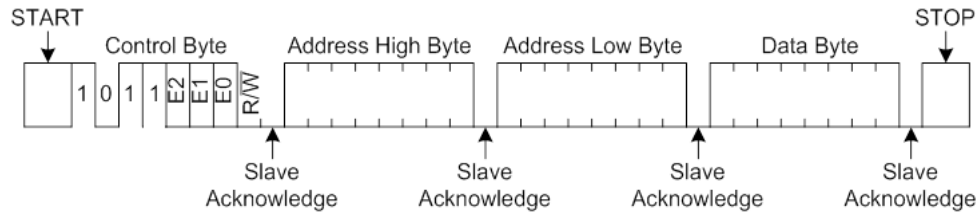

9. Maximize Bus Throughput by Write Cycle Polling using ACK

The fact that the device does not acknowledge during a write cycle can be used to determine when the write cycle is complete. By polling the device during the write cycle, bus throughput can be maximized.

Once the STOP command for the write cycle is sent by the master, the device initiates the internally timed write cycle. Acknowledge polling, by the master, can be initiated immediately. Acknowledge polling involves the master sending a START command, followed by the control byte for a write command ($R/\bar{W} = 0$). If the device is still busy with the write cycle, no acknowledge is returned. If no acknowledge is returned, the START command and control byte can be re-transmitted. If the write cycle is complete, the device returns an acknowledge. The master can then proceed with the next read or write command. See for a flow diagram.

NOTE: Care must be taken when polling the device. The control byte that was used to initiate the write must match the control byte used for polling.

Figure 9-1. Write Cycle Polling Flow Using ACK

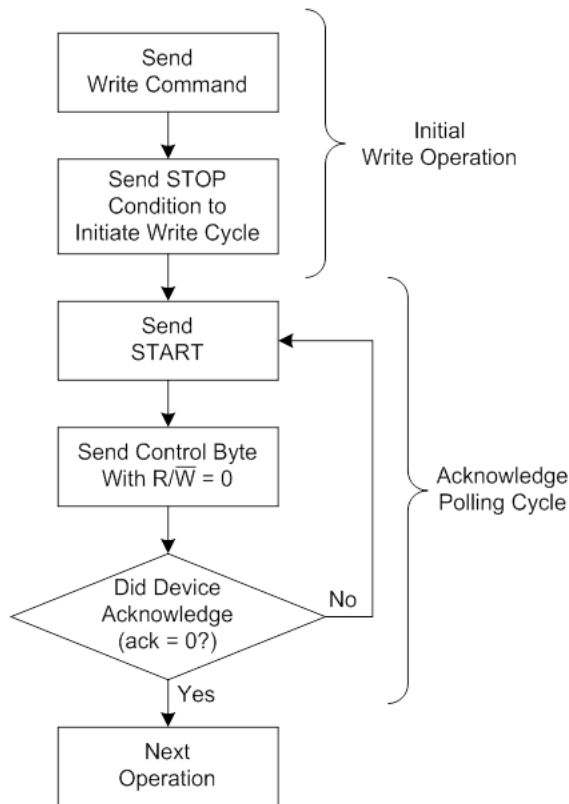

10. OTP Security Register Write Operation

The RM24C64AF device contains a specialized OTP security register that can be used for purposes such as unique device serialization or locked key storage. The OTP register is organized as follows:

- The register is comprised of a total of 128 bytes divided into two portions.
- The first 64 bytes (byte locations 0 through 63) are allocated as an One-Time Programmable space.
- The first 63 bytes (byte locations 0 through 62) can be programmed (but not erased) in any order as long as byte 63 is not programmed.
- Once byte 63 is programmed to any value (including 0xFF), the OTP register is locked, and no further programming operations are allowed.
- The remaining 64 bytes of the register (byte locations 64 through 127) are factory programmed by Adesto and contains a unique value for each device. The factory programmed data is fixed and cannot be changed.

Table 10-1. OTP Security Register

	Security Register Byte Number							
	0	1	...	63	64	65	...	127
Data Type	One-Time User Programmable				Factory Programmed by Adesto			

The OTP security register write operation is similar to the page write operation, except that the control code (the first four bits of the command byte) is “1011” instead of “1010”.

During a security register write cycle, a page with up to 64 bytes of data can be written in one continuous write command. The security register write starts in the same manner as the byte write. In a security register write, after the acknowledge following the first data byte, the master does not send a STOP, but continues to send additional data bytes. (See Figure 10-1.) At the end of the number of bytes to be written, the master sends a STOP command. Once the STOP command is sent, the device writes all the data bytes into memory, starting at the address location given in the address bytes.

Note that the lower 6 bits of the address are considered by the OTP Security register write operation. Address bit A6 must be set to 0 to write to the OTP security register. The upper 9 bits must be 0. Any attempt to write to address 128, for instance, is ignored.

If the master should transmit more than 64 bytes prior to generating the STOP command, the internal 64-byte data buffer in the device will wrap around and the first data bytes transmitted will be overwritten.

The internal address pointer does not increment beyond a page boundary but instead wraps around to the first byte of the OTP security register.

As with the byte write cycle, once the STOP command is received the device enters a write cycle. During the write cycle, the device does not generate an acknowledge signal. Meanwhile, the master can poll the device to determine when the write cycle is complete by sending it a control byte and looking for an acknowledge. Once the write cycle has completed, the device acknowledges the control byte sent to it.

During the OTP security register write cycle, the first byte in the data byte buffer is written to the address location indicated by the address bytes transmitted to the device. Each successive data byte is written to successive address locations.

Note that the OTP security register write operation is internally executed by sequentially writing the words in the page buffer. Therefore, the OTP security register write time can be estimated as byte write time multiplied by the number of words to be written.

Note that each byte in the OTP security register can only be written once. Care should be taken to avoid writing to already written locations. The result of writing to the same location more than once is undefined.

Figure 10-1. OTP Security Register Write Cycle

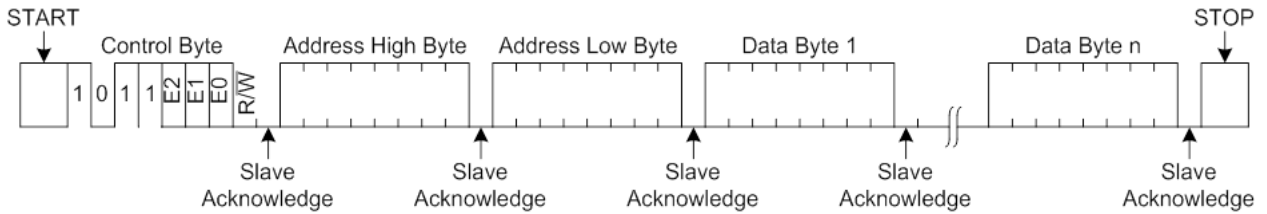

11. Read Operation

Read operations are initiated in the same way as the write operations, except that the R/\bar{W} bit of the control byte is set to one. There are three types of read operations: current address read, random read, and sequential read.

Note that the same address pointer is used for accessing both the EEPROM array and the OTP security registers. Changes done to the address register as a result of access to one of the arrays affect the access of the other unless the address pointer gets updated again.

11.1 Current Address Read

The device internal address pointer maintains the address of the last word accessed, internally incremented by one. Therefore, if the previous read access was to address n (any legal address), the next current address read operation would access data from address $n+1$. After the last memory address, the address counter “rolls-over”, and the device continues to output data from memory address 00h.

If a current address read is performed after a byte write or page write, care must be taken to understand that during the page/byte write command, the address can wrap around within the same page.

Upon receipt of the control byte with the R/\bar{W} bit set to one, the device issues an acknowledge and transmits the 8-bit data word located at the address of the internal address pointer. The master does not acknowledge the transfer, but does generate a STOP condition and the device discontinues transmission. See Figure 11-1.

Figure 11-1. Current Address Read

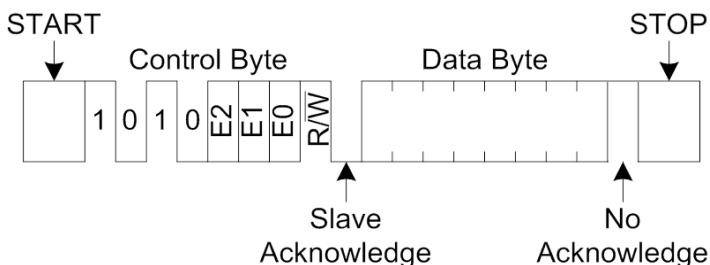

11.2 Random Read

Random read operations allow the master to access any memory location in a random manner. To perform a Random Read, first the address to be accessed must be set. This is done by sending the address to the device as part of a write operation ($R/\bar{W} = 0$). After the address is sent and acknowledged by the device, the master generates a START. This terminates the write operation, but the address pointer is set to the address sent. The master then issues the same control byte as the write operation, but with the R/\bar{W} bit set to 1. The device acknowledges and transmits the 8-bit data byte located at the address location written. The master does not acknowledge the transfer of the data byte, but instead generates a STOP condition, which causes the device to discontinue transmission. See Figure 11-2. After the random read operation, the internal address counter increments to the address location following the one that was just read.

Figure 11-2. Random Read

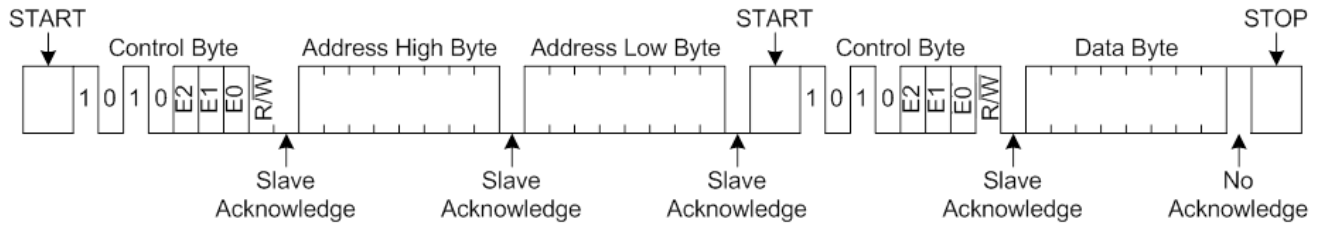

11.3 Sequential Read

A sequential read allows the whole memory contents to be serially read during one operation. A sequential read is initiated in the same way as a random read except that after the device transmits the first data byte, the master issues an acknowledge instead of a STOP condition. This acknowledge from the master directs the device to transmit the next sequentially addressed byte (See Figure 11-3). Following the final byte transmitted to the master, the master does not generate an acknowledge, but rather generates a STOP condition which causes the device to discontinue transmission.

To provide the sequential read, the device contains an internal address pointer which is incremented by one at each acknowledge received by the master, and by the STOP condition.

Figure 11-3. Sequential Read

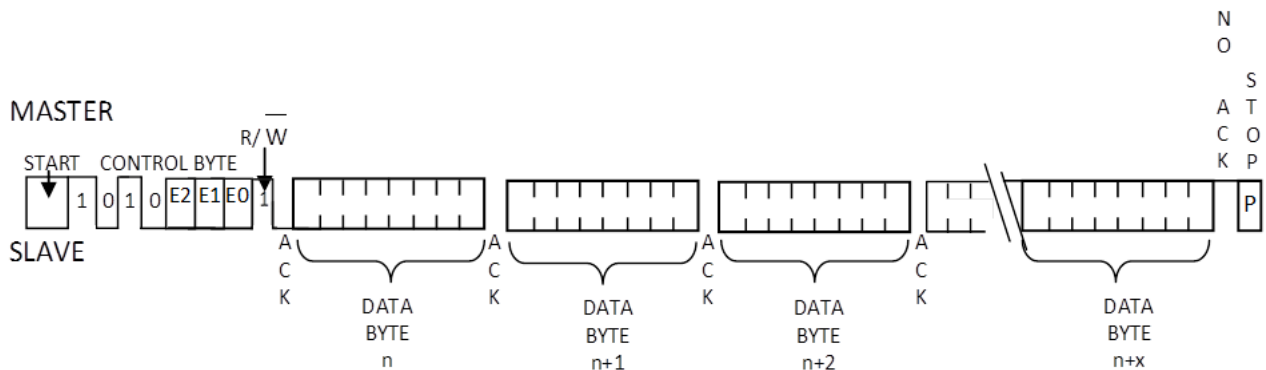

12. Write Protect Register Read Operation

Write Protect (WP) register read operations are initiated in the same way as the write operations, except that the $\overline{R/W}$ bit of the control byte is set to one.

Note that the same address pointer is used for accessing both the EEPROM array, the WP register and the OTP security registers. Changes done to the address register as a result of access to one of the arrays affect the access of the other unless the address pointer gets updated again. It is recommended that when the user switches between accessing the EEPROM array, the WP register or the OTP register, a random read is used to explicitly set the address.

The WP Register Read operations will require the address pointer to be set to 0401h.

12.1 Write Protect Register Current Address Read

The device internal address pointer maintains the address of the last word accessed, internally incremented by one. Therefore, if the previous read access was to address n (any legal address), the next current address read operation would access data from address $n+1$. Upon receipt of the control byte with the $\overline{R/W}$ bit set to one, the device issues an acknowledge and transmits the 8-bit data word located at the address of the internal address pointer. The master does not acknowledge the transfer, but does generate a STOP condition and the device discontinues transmission. See Figure 12-1.

Figure 12-1. Write Protect Register Current Address Read

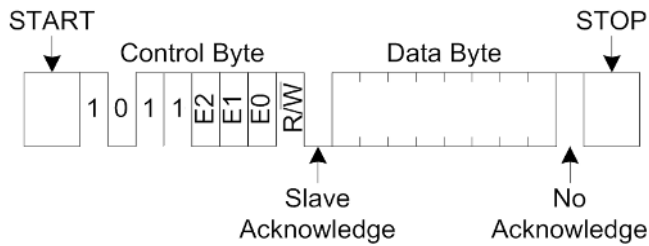

12.2 Write Protect Register Read

To perform a Write Protect Register Read, first the address to be accessed must be set to 0401h. This is done by sending the address to the device as part of a write operation ($R/\bar{W} = 0$). After the address is sent and acknowledged by the device, the master generates a START. This terminates the write operation, but the address pointer is set to the address of the WP Register. The master then issues the same control byte as the write operation, but with the R/\bar{W} bit set to 1. The device acknowledges and transmits the 8-bit data byte located at the address location written. The master does not acknowledge the transfer of the data byte, but instead generates a STOP condition, which causes the device to discontinue transmission. See Figure 12-2. After the WP register read operation, the internal address counter increments to the address location following the one that was just read.

Figure 12-2. WP Register Read

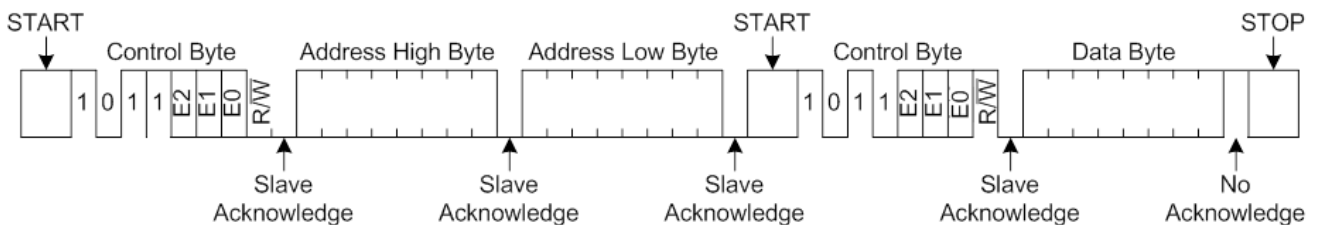

13. OTP Security Register Read Operation

OTP security register read operations are initiated in the same way as the write operations, except that the R/\bar{W} bit of the control byte is set to one. There are three types of OTP Security Register Read operations: OTP Security Register current address read, OTP security register random read, and OTP security register sequential read.

Note that the same address pointer is used for accessing both the EEPROM array, the WP register and the OTP security registers. Changes done to the address register as a result of access to one of the arrays affect the access of the other unless the address pointer gets updated again. It is recommended that when the user switches between accessing the EEPROM array, the WP register or the OTP register, a random read is used to explicitly set the address.

The OTP security register read operations require the upper 9 bits of the address pointer to all be 0, but all bits of the address pointer are updated by these read operations.

Reading address 0 - 63 provides access to the user programmable section of the OTP security registers, while reading address 64 - 127 provides access to the registers that are factory programmed by Adesto. See [Table I](#) for details.

13.1 OTP Security Register Current Address Read

The device internal address pointer maintains the address of the last word accessed, internally incremented by one. Therefore, if the previous read access was to address n (any legal address), the next current address read operation would access data from address $n+1$. Upon receipt of the control byte with the R/\bar{W} bit set to one, the device issues an acknowledge and transmits the 8-bit data word located at the address of the internal address pointer. The master does not acknowledge the transfer, but does generate a STOP condition and the device discontinues transmission. See Figure 13-1.

Figure 13-1. OTP Security Register Current Address Read

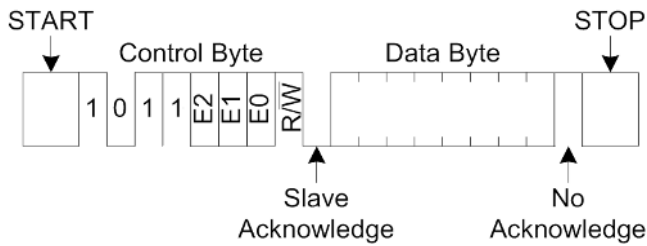

13.2 OTP Security Register Random Read

Random read operations allow the master to access any OTP Security Register location in a random manner. To perform a OTP Security Register Random Read, first the address to be accessed must be set. This is done by sending the address to the device as part of a write operation ($R/\bar{W} = 0$). After the address is sent and acknowledged by the device, the master generates a START. This terminates the write operation, but the address pointer is set to the address sent. The master then issues the same control byte as the write operation, but with the R/\bar{W} bit set to 1. The device acknowledges and transmits the 8-bit data byte located at the address location written. The master does not acknowledge the transfer of the data byte, but instead generates a STOP condition, which causes the device to discontinue transmission. See Figure 13-2. After the OTP security register random read operation, the internal address counter increments to the address location following the one that was just read.

Figure 13-2. OTP Security Register Random Read

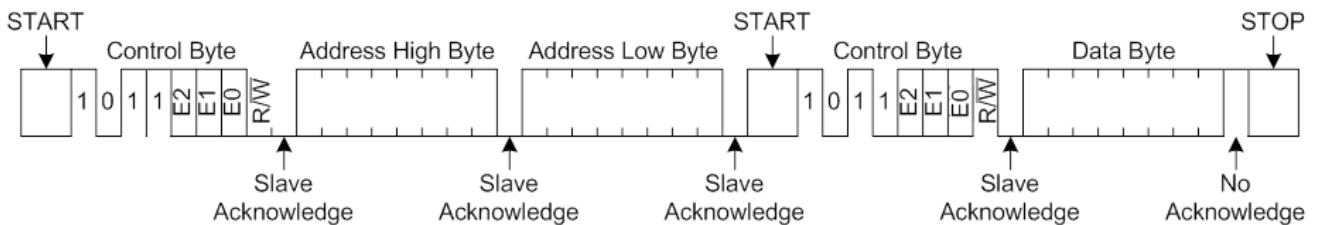

13.3 OTP Security Register Sequential Read

Sequential read allows the whole OTP security register contents to be serially read during one operation. A sequential read operation is initiated in the same way as a random read except that after the device transmits the first data byte, the master issues an acknowledge instead of a STOP condition. This acknowledge from the master directs the device to transmit the next sequentially addressed byte (See Figure 13-3). Following the final byte transmitted to the master, the master does not generate an acknowledge, but rather generates a STOP condition which causes the device to discontinue transmission.

To provide the OTP security register sequential read, the device contains an internal address pointer which is incremented by one at each acknowledge received by the master, and by the STOP condition.

Figure 13-3. OTP Security Register Sequential Read

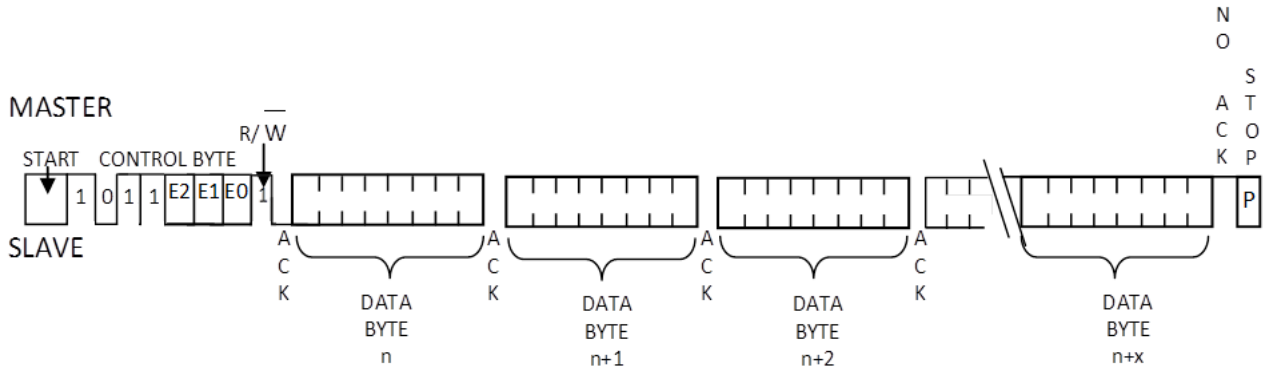

14. Electrical Specifications

14.1 Absolute Maximum Ratings*

Table 14-1. Absolute Maximum Ratings

Parameter	Specification
Operating ambient temp range	-40°C to +85°C
Storage temperature range	-65°C to +125°C
Input supply voltage, V_{CC} to GND	- 0.5V to 2.7V
Voltage on any pin with respect to GND	-0.5V to ($V_{CC} + 0.5V$)
ESD protection on all pins (Human Body Model)	>2kV

*NOTICE: Stresses beyond those listed under “Absolute Maximum Ratings” may cause permanent damage to the device. This is a stress rating only and functional operation of the device at these, or any other conditions beyond those indicated in the operational sections of this specification, is not implied. Exposure to absolute maximum rating conditions for extended periods may affect device reliability.

14.2 DC Characteristics

Table 14-2. DC Characteristics ⁽¹⁾

Symbol	Parameter	Condition	Min	Typ	Max	Units
		$T_A = -40^{\circ}\text{C to } +85^{\circ}\text{C}, V_{CC} = 1.65\text{V to } 2.2\text{V}$				
V_{CC}	Supply range	1.65V to 2.2V	1.65		2.2	V
I_{CC1}	Supply current, read	$V_{CC} = 2.2\text{V}$ SCL at 1MHz		0.2	0.5	mA
I_{CC2}	Supply current, write	$V_{CC} = 2.2\text{V}$		1.0	2	mA
I_{CC3}	Supply current, standby ⁽²⁾	$V_{CC} = 2.2\text{V}$. SCL = SDA = 2.2V		15	35	μA
I_{IL}	Input leakage	SCL, SDA, $V_{IN} = 0\text{V}$ or V_{CC}			± 1	μA
I_{OL}	Output leakage	SDA $V_{IN} = 0\text{V}$ to V_{CC}			± 1	μA
V_{IL}	Input low voltage	SCL, SDA	-0.5		$V_{CC} \times 0.3$	V
V_{IH}	Input high voltage	SCL, SDA	$V_{CC} \times 0.7$		$V_{CC} + 0.5$	V
V_{OL}	Output low voltage	SDA $I_{OL} = 300 \mu\text{A}$			0.2	V

1. Applicable over the recommended operating range: $T_A = -40^{\circ}\text{C}$ to $+85^{\circ}\text{C}$, $V_{CC} = 1.65\text{V}$ to 2.2V , $CL = C_B \leq 100\text{pF}$

2. Values are based on device characterization, not 100% tested in production.

14.3 AC Characteristics

Applicable over recommended operating range: $T_A = -40^{\circ}\text{C}$ to $+85^{\circ}\text{C}$, $V_{CC} = 1.65\text{V}$ to 2.2V , $C_L = C_B \leq 100\text{pF}$

Symbol	Parameter	Min	Typ	Max	Units
f_{CLK}	SCL clock frequency	$V_{CC} \geq 1.65\text{V}$	0	1	MHz
t_{RI}	SCL and SDA input rise time ⁽¹⁾			300	ns
t_{FL}	SCL and SDA input fall time ⁽¹⁾			100	ns
t_{SCLH}	SCL high time	500			ns
t_{SCLL}	SCL low time	500			ns
t_{STH}	START condition hold time	250			ns
t_{STS}	START condition setup time	250			ns
t_{DAH}	Data input hold time ⁽²⁾	0			ns
t_{DAS}	Data input setup time	100			ns
t_{STPS}	STOP condition hold time	250			ns
t_{OV}	Output valid from clock ⁽²⁾			400	ns
t_{BFT}	Bus free time: time the bus must be free before a new transmission can start	500			ns
t_{OF}	Output fall time from VIH min to VIL max, $C_B < 100\text{pF}$	$10 + 0.1 C_B$		250	ns
t_{SP}	Input filter spike suppression, SDA and SCL pins			50	ns
t_{WW}	Word write cycle time (four bytes)		40	70	μs
t_{PW}	Page write cycle time, 32 byte write (full page)		0.28	0.5	ms
t_{OTPPW}	OTP Security Register word write cycle time (four bytes)		40	$70^{(3)}$	μs
t_{OTPPW}	OTP Security Register page write cycle time, 32 byte write (full page)		0.28	$0.5^{(4)}$	ms
Endurance		10,000 ⁽⁵⁾			Write Cycles
		Unlimited ⁽⁶⁾			Read Cycles
Retention		10			Years

1. This parameter is ensured by characterization only.
2. As a transmitter, the device must provide an internal minimum delay time to bridge the undefined region (minimum 300ns) of the falling edge of SCL to avoid unintended generation of START or STOP conditions.
3. The Word Write cycle time is the same for the OTP Security Register as for the regular memory. However, if the byte address 63 is included in the OTP Security Register Write command, then the Word Write time will increase by $40\mu\text{s}$ (typ) and $70\mu\text{s}$ (max).
4. The Page Write cycle time is the same for the OTP Security Register as for the regular memory. However, as the byte address 63 is included in the OTP Security Register Write command, the Page Write time is increased by $50\mu\text{s}$ (typ) and $80\mu\text{s}$ (max).
5. Note that even though the device supports single byte operation, it operates internally on 4-byte words. To achieve this endurance number, write operations have to be performed on multiples of 4 bytes. (Address bits A1 and A0 both have to be 0.)
6. Subject to expected 10-year data retention specification.

15. Mechanical Dimensions

15.1 WLCSP, 0.3mm Package Height (Contact Adesto)

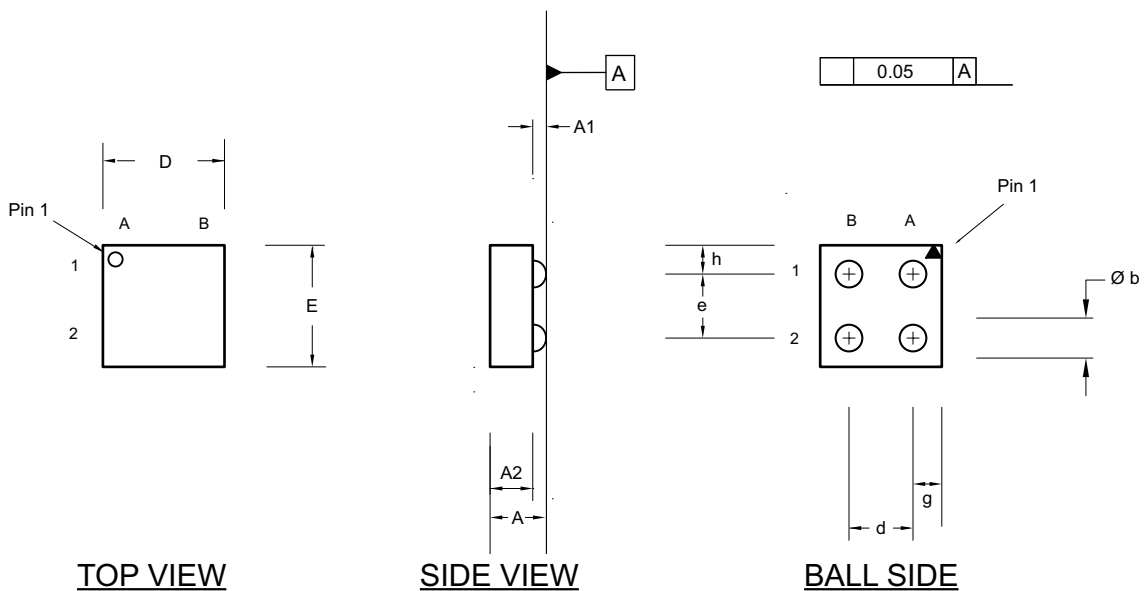

* Dimensions are NOT to scale.

Pin Assignment Matrix

	A	B
1	V _{CC}	GND
2	SCL	SDA

COMMON DIMENSIONS
(Unit of Measure = mm)

SYMBOL	MIN	TYP	MAX	NOTE
A	0.24	0.27	0.30	
A1		0.055	0.07	
A2		0.215		
E	0.73	0.75	0.77	
D	0.73	0.75	0.77	
b		0.165	0.19	
d		0.4		
e		0.4		
g		0.18		
h		0.18		

01/26/17

<p>Package Drawing Contact: contact@adestotech.com</p>	<p>TITLE CS4-3, 4-ball (2x2 Array), 0.30mm max package height, Wafer Level Chip Scale Package, WLCSP</p>	GPC	DRAWING NO.	REV.
		DEC	CS4-3	0A

16. Ordering Information

16.1 Ordering Detail

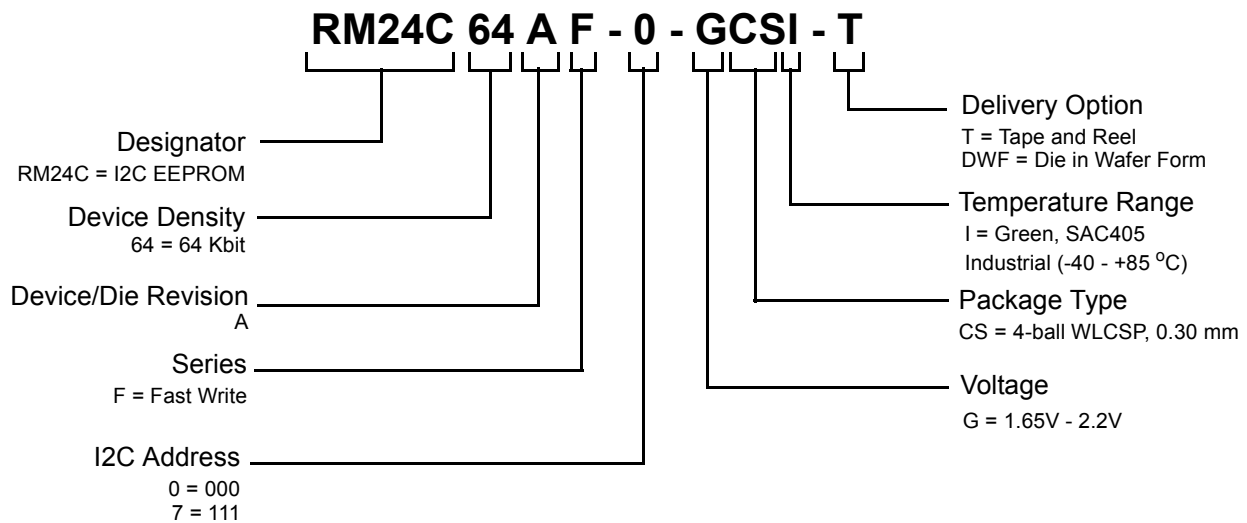

16.2 Ordering Codes

Ordering Code	I2C Address	Package	Density	Operating Voltage	Device Grade	Delivery Option	Qty. Carrier
RM24C64AF-0-GCSI-T	0 = "000"	CS	64 Kbit	1.65V to 2.2V	Industrial (-40°C to 85°C)	Contact Factory	
RM24C64AF-7-GCSI-T	7 = "111"						
RM24C64AF-0-GI-DWF	0 = "000"						
RM24C64AF-7-GI-DWF	7 = "111"						
Package Type							
CS	CS4-3, 4-ball, 2x2 Array, 0.30mm max package height, Wafer Level Chip Scale Package (WLCSP)						

17. Revision History

Doc. Rev.	Date	Comments
RM24C64AF-137A	5/2017	Initial document release. Updated standby current and t _{pw} specifications.
RM24C64AF-137B	9/2017	Updated write protect feature. Updated V _{OL} specification.
RM24C64AF-137C	10/2017	Updated specifications, t _{PWD} , t _{PUD} , ICC3. Updated Table 4-1. Removed Figures 4-2 and 4-3.
RM24C64AF-137D	3/2018	Updated V _{cc} rise time, I _{cc1} and I _{cc2} and V _{ol} .
RM24C64AF-137E	4/2018	Updated Figure 4-1, Bus Timing Data. Added Figure 7-2, Page Write Cycle Timing.
RM24C64AF-137F	9/2018	Updated Ordering Codes table in Section 16.2. Change document status from Advanced to Preliminary. Update input supply voltage range in Table 14.1, Absolute Maximum Ratings. Update input low minimum voltage in Section 14.2, DC Characteristics. Update input high maximum voltage in Section 14.2, DC Characteristics. Changed package grade to SAC405.
RM24C64AF-137G	3/2019	Changed data sheet status. Removed 'Preliminary' wording from front page. Change timing t _{DV} to t _{OV} in Figure 4-1. Updated legal notice on back page. Removed 'Tube' shipping option in Section 16.1, Ordering Detail. Added DWF package type.



Corporate Office

California | USA

Adesto Headquarters

3600 Peterson Way

Santa Clara, 95054

Phone: (+1) 408.400.0578

Email: contact@adestotech.com

© 2019 Adesto Technologies. All rights reserved. DS-RM24C64AF-137G-03/2019

Adesto, the Adesto logo, CBRAM and DataFlash are trademarks or registered trademarks of Adesto Technologies Corporation in the United States and other countries. Other company, product, and service names may be trademarks or service marks of others. Adesto products are covered by one or more patents listed at <http://www.adestotech.com/patents>.

Disclaimer: Adesto Technologies Corporation ("Adesto") makes no warranties of any kind, other than those expressly set forth in Adesto's Terms and Conditions of Sale at <http://www.adestotech.com/terms-conditions>. Adesto assumes no responsibility or obligations for any errors which may appear in this document, reserves the right to change devices or specifications herein at any time without notice, and does not make any commitment to update the information contained herein. No licenses to patents or other intellectual property of Adesto are granted by Adesto herewith or in connection with the sale of Adesto products, expressly or by implication. Adesto's products are not authorized for use in medical applications (including, but not limited to, life support systems and other medical equipment), weapons, military use, avionics, satellites, nuclear applications, or other high risk applications (e.g., applications that, if they fail, can be reasonably expected to result in personal injury or death) or automotive applications, without the express prior written consent of Adesto.

Компания «Life Electronics» занимается поставками электронных компонентов импортного и отечественного производства от производителей и со складов крупных дистрибьюторов Европы, Америки и Азии.

С конца 2013 года компания активно расширяет линейку поставок компонентов по направлению коаксиальный кабель, кварцевые генераторы и конденсаторы (керамические, пленочные, электролитические), за счёт заключения дистрибьюторских договоров

Мы предлагаем:

- Конкурентоспособные цены и скидки постоянным клиентам.
- Специальные условия для постоянных клиентов.
- Подбор аналогов.
- Поставку компонентов в любых объемах, удовлетворяющих вашим потребностям.
- Приемлемые сроки поставки, возможна ускоренная поставка.
- Доставку товара в любую точку России и стран СНГ.
- Комплексную поставку.
- Работу по проектам и поставку образцов.
- Формирование склада под заказчика.
- Сертификаты соответствия на поставляемую продукцию (по желанию клиента).
- Тестирование поставляемой продукции.
- Поставку компонентов, требующих военную и космическую приемку.
- Входной контроль качества.
- Наличие сертификата ISO.

В составе нашей компании организован Конструкторский отдел, призванный помогать разработчикам, и инженерам.

Конструкторский отдел помогает осуществить:

- Регистрацию проекта у производителя компонентов.
- Техническую поддержку проекта.
- Защиту от снятия компонента с производства.
- Оценку стоимости проекта по компонентам.
- Изготовление тестовой платы монтаж и пусконаладочные работы.



Тел: +7 (812) 336 43 04 (многоканальный)

Email: org@lifeelectronics.ru