

Features

- NEMA 4X* (IP 65) and 6P (IP 67)
*Enclosure is 4X. For additional corrosion protection of mounting hardware, use model OSYSU-2 CRH
- -40° to 140° (-40°C to 60°C) operating temperature range
- Visual switch indicators
- Two conduit entrances
- Adjustable length trip rod
- Accommodates up to 12AWG wire
- Three position switch detects tampering and valve closure
- Knurled mounting bracket prevents slipping
- Fine adjustment feature for fast, easy installation
- RoHS compliant
- One or two SPDT contact models (-1,-2)

NOTICE

Before any work is done on the fire sprinkler or fire alarm system, the building owner or their authorized representative shall be notified. Before opening any closed valve, ensure that opening the valve will not cause any damage from water flow due to open or missing sprinklers, piping, etc.



Important: This document contains important information on the installation and operation of OS&Y valve supervisory switches. Please read all instructions carefully before beginning installation. A copy of this document is required by NFPA 72 to be maintained on site.

Description

The OSYSU is used to monitor the open position of an OS&Y (outside screw and yoke) type gate valve. This device is available in two models; the OSYSU-1, containing one set of SPDT (Form C) contacts and the OSYSU-2, containing two sets of SPDT (Form C) contacts. These switches mount conveniently to most OS&Y valves ranging in size from 2" to 12" (50mm to 300mm). They will mount on some valves as small as 1/2" (12,5mm).

The cover is held in place by two tamper resistant screws that require a special tool to remove. The tool is furnished with each device.

Testing

The operation of the OSYSU and its associated protective monitoring system shall be inspected, tested, and maintained in accordance with all applicable local and national codes and standards and/or the Authority Having Jurisdiction (manufacturer recommends quarterly or more frequently). A minimum test shall consist of turning the valve wheel towards the closed position. The OSYSU shall operate within the first two revolutions of the wheel. Fully close the valve and ensure that the OSYSU does not restore. Fully open the valve and ensure that the OSYSU restores to normal only when the valve is fully opened.

CAUTION

Close the valve fully to determine that the stem threads do not activate the switch. The switch being activated by the stem threads could result in a **false valve open** indication.

Technical Specifications

Dimensions	See Fig 8
Weight	1.6 lbs (0,73 kg)
Enclosure	Cover: Die Cast Finish: Red Powder Coat Base: Die Cast Finish: Black Powder Coat All parts have corrosion resistant finishes
Cover Tamper	Tamper Resistant Screws Optional Cover Tamper Switch Available
Contact Ratings	OSYSU-1: One Set of SPDT (Form C) OSYSU-2: Two Sets of SPDT (Form C) 10.0 Amps at 125/250 VAC 2.0 Amps at 30VDC Resistive 10 mAmps minimum at 24 VDC
Environmental Limitations	-40° F to 140°F (-40°C to 60°C) NEMA 4X (IP 65) and NEMA 6P (IP 67) Enclosure (Use suitably rated conduit and connector) Indoor or Outdoor Use (See OSYSU-EX Bulletin 5400705 for Hazardous locations)
Conduit Entrances	Two Knockouts for 1/2" conduit provided (See Notice on Page 6)
Service Use	NFPA 13, 13D, 13R, 72

Specifications subject to change without notice

Theory of Operation

The OSYSU is a 3 position switch. The center position is the normal installation position. Normal is when the switch is installed on the OS&Y valve, the valve is fully open and the trip rod of the OSYSU is in the groove of the valve stem. Closing the valve causes the trip rod to ride up out of the groove and activates the switches. Removing the OSYSU from the valve causes the spring to pull the trip rod in the other direction and activates the switches.

Visual Switch Status Indication

There are 3 visual indicators to determine the status of the switches.

Fig 1; the actuator button of the micro switches are on the raised section of the switch actuator.

Fig 2; the trip rod is perpendicular to the base and lined up with the alignment mark on the mounting bracket.

Fig 3; the white visual indicator is visible through the window on the back of the switch actuator.

A final test is to meter the contacts marked COM and N.O. to ensure they are an open circuit when the valve is open and that they close and have continuity within 2 revolutions of turning the valve handwheel towards the closed position and the contacts remain closed as the valve is completely closed and until the valve is completely opened when the trip rod drops back into the groove in the valve stem.

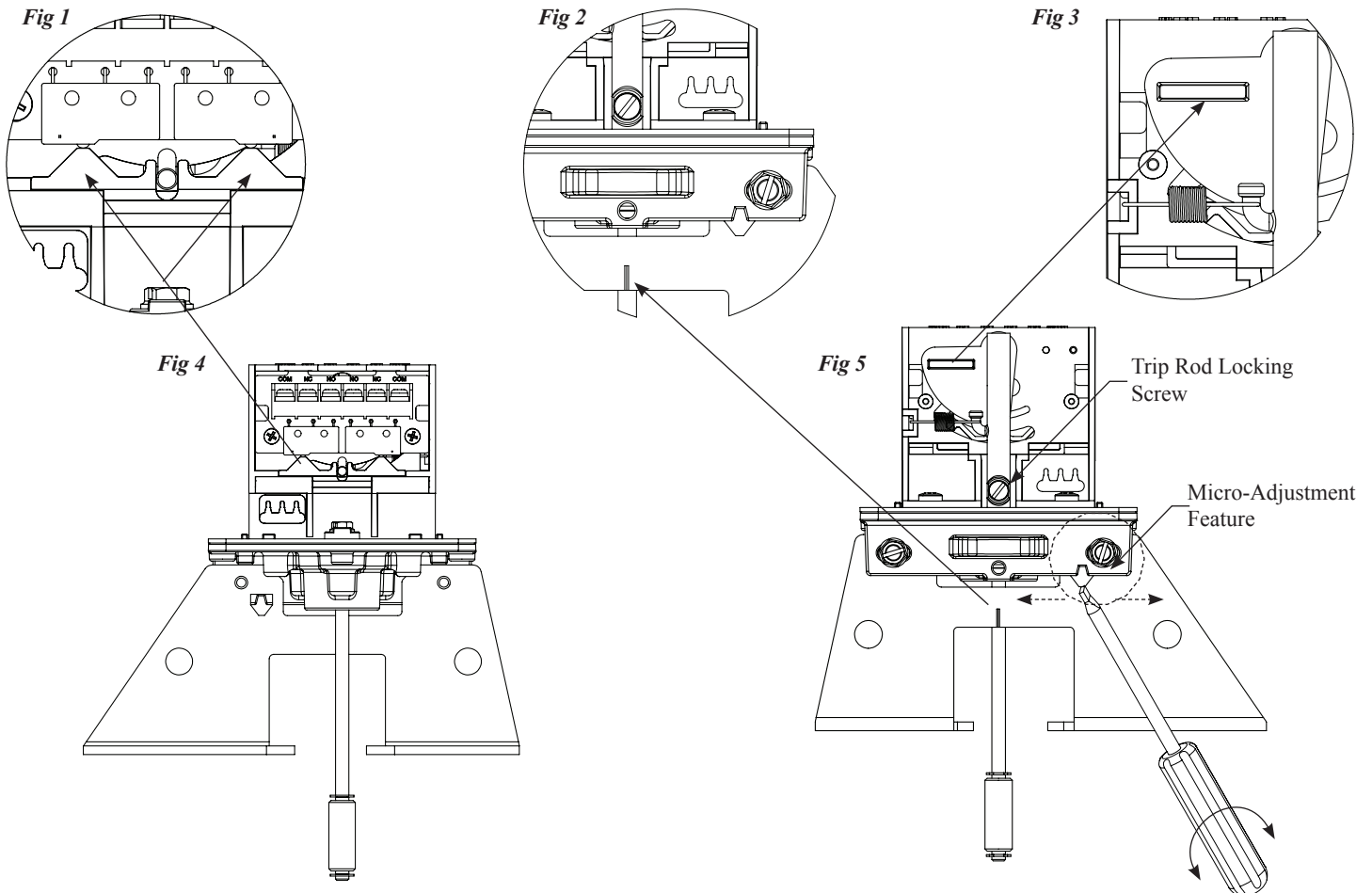
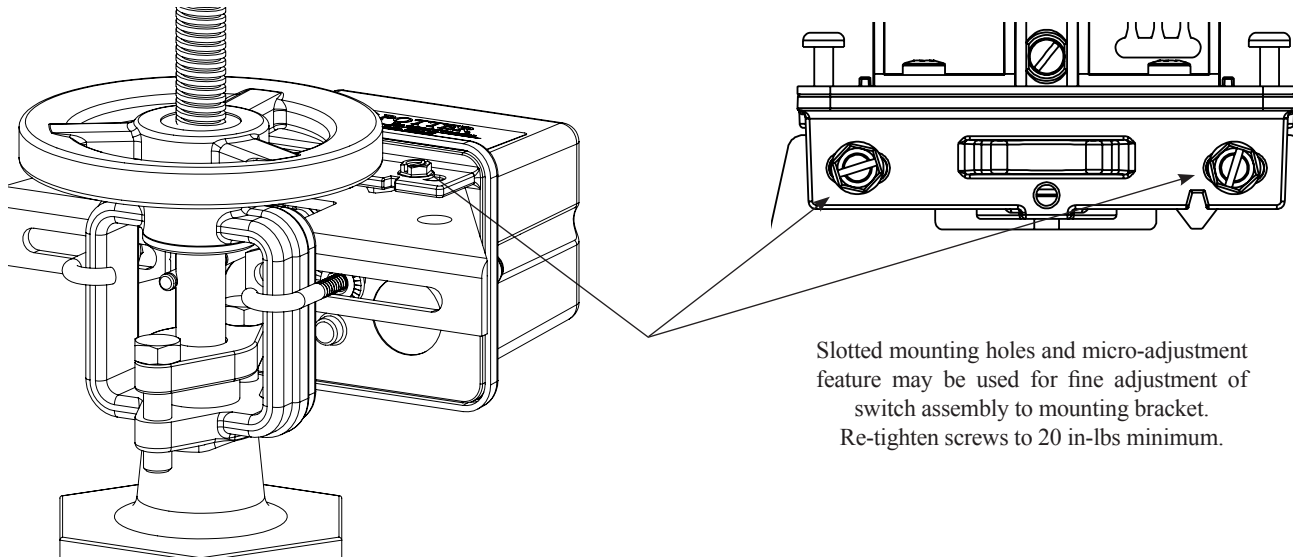

Fig 6

Small Valve Installation - 1/2" Through 2 1/2" Sizes



Slotted mounting holes and micro-adjustment feature may be used for fine adjustment of switch assembly to mounting bracket.
Re-tighten screws to 20 in-lbs minimum.

Small Valve Installation

NOTE: If the valve stem is pre-grooved at 1/8" minimum depth; proceed to step 7.

1. Remove and discard "E" ring and roller from the trip rod.
 2. With the valve in the FULL OPEN position, locate the OSYSU across the valve yoke as far from the valve gland so that the spring loaded trip rod of the OSYSU is pulled against the non threaded portion of the valve stem. Position the OSYSU with the bracket near the handwheel as shown in Fig. 6 if possible to avoid creating a pinch point between the wheel and the OSYSU.
 3. Loosen the locking screw that holds the trip rod in place and adjust the rod length (see Fig. 5). When adjusted properly, the rod should extend past the valve screw, but not so far that it contacts the clamp bar. Tighten the locking screw to 5 in-lbs minimum to hold the trip rod in place and properly seal the enclosure.
- NOTE:** If trip rod length is excessive, loosen the locking screw and remove the trip rod from the trip lever. Using pliers, break off the one (1) inch long notched section (see Fig. 9). Reinstall trip rod and repeat Step 3 procedure.
4. Mount the OSYSU loosely with the carriage bolts and clamp bar supplied. On valves with limited clearance use J-hooks supplied instead of the carriage bolts and clamp bar to mount the OSYSU.
 5. Mark the valve stem at the center of the trip rod.
 6. Remove the OSYSU. Utilizing a 3/16" or 1/4" diameter straight file, file a 1/8" minimum depth groove centered on the mark on the valve stem. Deburr and smooth the edges of the groove to prevent damage to the valve packing and to allow the trip rod to move easily in and out of the groove as the valve is operated.

NOTE: A groove depth of up to approximately 3/16" can

make it easier to install the OSYSU so that it does not restore as it rolls over by the threads of the valve stem.

7. Mount the OSYSU on the valve yoke with the spring loaded trip rod of the OSYSU pulled against the valve stem and centered in the groove of the stem. If possible, position the OSYSU with the flat side of the bracket toward the hand wheel, as shown in Fig. 6, to help avoid creating a pinch point between the wheel and OSYSU. When in this preferred mounting position, it is usually best to use the white indicator visible through the window, as illustrated in Fig. 3, to aid in initially locating the OSYSU in the correct position on the yoke. If the unit must be installed inverted with the white indicator no longer easily visible, use the visual indicators of the actuator buttons on the micro-switches, as illustrated in Fig. 1, or the trip rod alignment mark on the bracket, as illustrated in Fig. 2, to aid in initially locating the OSYSU.
8. Final adjustment can be made by slightly loosening the two screws on the bracket and using the fine adjustment feature (see Fig. 5). The adjustment is correct when the plungers on the switches are depressed by the actuator and there is no continuity between the COM and NO terminals on the switches.
9. Tighten the adjustment screws and all mounting hardware securely (20 in-lbs minimum). Check to insure that the rod moves out of the groove easily and that the switches activate within two turns when the valve is operated from the FULL OPEN towards the CLOSED position.
10. Reinstall the cover and tighten the cover screws to 15 in-lbs minimum to properly seal the enclosure.

<p>CAUTION</p>
<p>Close the valve fully to determine that the stem threads do not activate the switch. The switch being activated by the stem threads could result in a <i>false valve open</i> indication.</p>

Fig 7 **Large Valve Installation - 3" Through 12" Sizes**

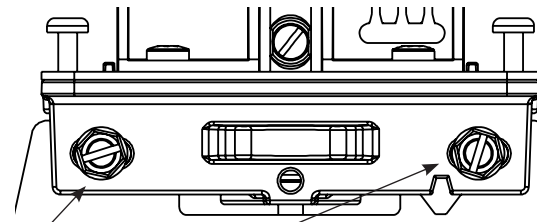
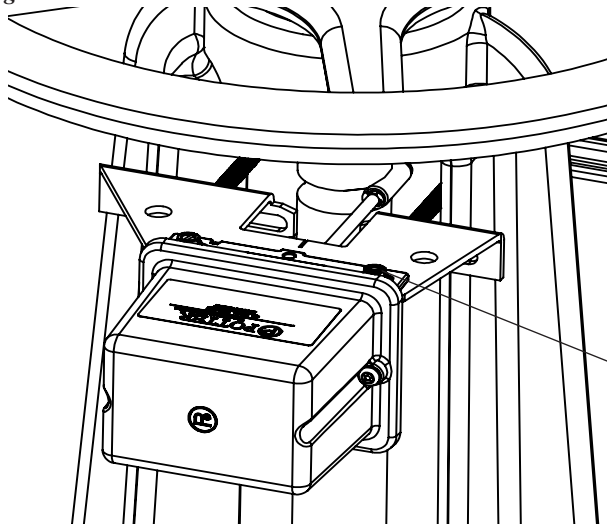

Slotted mounting holes and micro-adjustment feature may be used for fine adjustment of switch assembly to mounting bracket. Re-tighten screws to 20 in-lbs minimum.

Large Valve Installation

NOTE: If the valve stem is pre-grooved at 1/8" minimum depth; proceed to step 6.

1. With the valve in the FULL OPEN position, locate the OSYSU across the valve yoke as far from the valve gland so that the spring loaded trip rod of the OSYSU is pulled against the non threaded portion of the valve stem. Position the OSYSU with the bracket near the handwheel as shown in Fig. 7 if possible to avoid creating a pinch point between the wheel and the OSYSU.
 2. Mount the OSYSU loosely with the carriage bolts and clamp bar supplied.
 3. Loosen the locking screw that holds the trip rod in place and adjust the rod length (see Fig. 5). When adjusted properly, the rod should extend past the valve screw, but not so far that it contacts the clamp bar. Tighten the locking screw to 5 in-lbs minimum to hold the trip rod in place and properly seal the enclosure.
- NOTE:** If trip rod length is excessive, loosen the locking screw and remove the trip rod from the trip lever. Using pliers, break off the one (1) inch long notched section (see Fig. 9). Reinstall trip rod and repeat Step 3 procedure.
4. Mark the valve stem at the center of the trip rod.
 5. Remove the OSYSU. Utilizing a 3/8" or 1/2" diameter straight file, file a 1/8" minimum depth groove centered on the mark on the valve stem. Deburr and smooth the edges of the groove to prevent damage to the valve packing and to allow the trip rod to move easily in and out of the groove as the valve is operated.

NOTE: A groove depth of up to approximately 3/16" can make it easier to install the OSYSU so that it does not restore

as it rolls over by the threads of the valve stem.

6. Mount the OSYSU on the valve yoke with the spring loaded trip rod of the OSYSU pulled against the valve stem and centered in the groove of the stem. If possible, position the OSYSU with the flat side of the bracket toward the hand wheel, as shown in Fig. 7, to help avoid creating a pinch point between the wheel and OSYSU. When in this preferred mounting position, it is usually best to use the white indicator visible through the window, as illustrated in Fig. 3, to aid in initially locating the OSYSU in the correct position on the yoke. If the unit must be installed inverted with the white indicator no longer easily visible, use the visual indicators of the actuator buttons on the micro-switches, as illustrated in Fig. 1, or the trip rod alignment mark on the bracket, as illustrated in Fig. 2, to aid in initially locating the OSYSU.
7. Final adjustment can be made by slightly loosening the two screws on the bracket and using the fine adjustment feature (see Fig. 5). The adjustment is correct when the plungers on the switches are depressed by the actuator and there is no continuity between the COM and NO terminals on the switches.
8. Tighten the adjustment screws and mounting hardware securely (minimum 20 in-lbs). Check to insure that the rod moves out of the groove easily and that the switches activate within two turns when the valve is operated from the FULL OPEN towards the CLOSED position.
9. Reinstall the cover and tighten the cover screws to 15 in-lbs minimum to properly seal the enclosure.

CAUTION

Close the valve fully to determine that the stem threads do not activate the switch. The switch being activated by the stem threads could result in a **false valve open** indication.

Dimensions

Fig 8

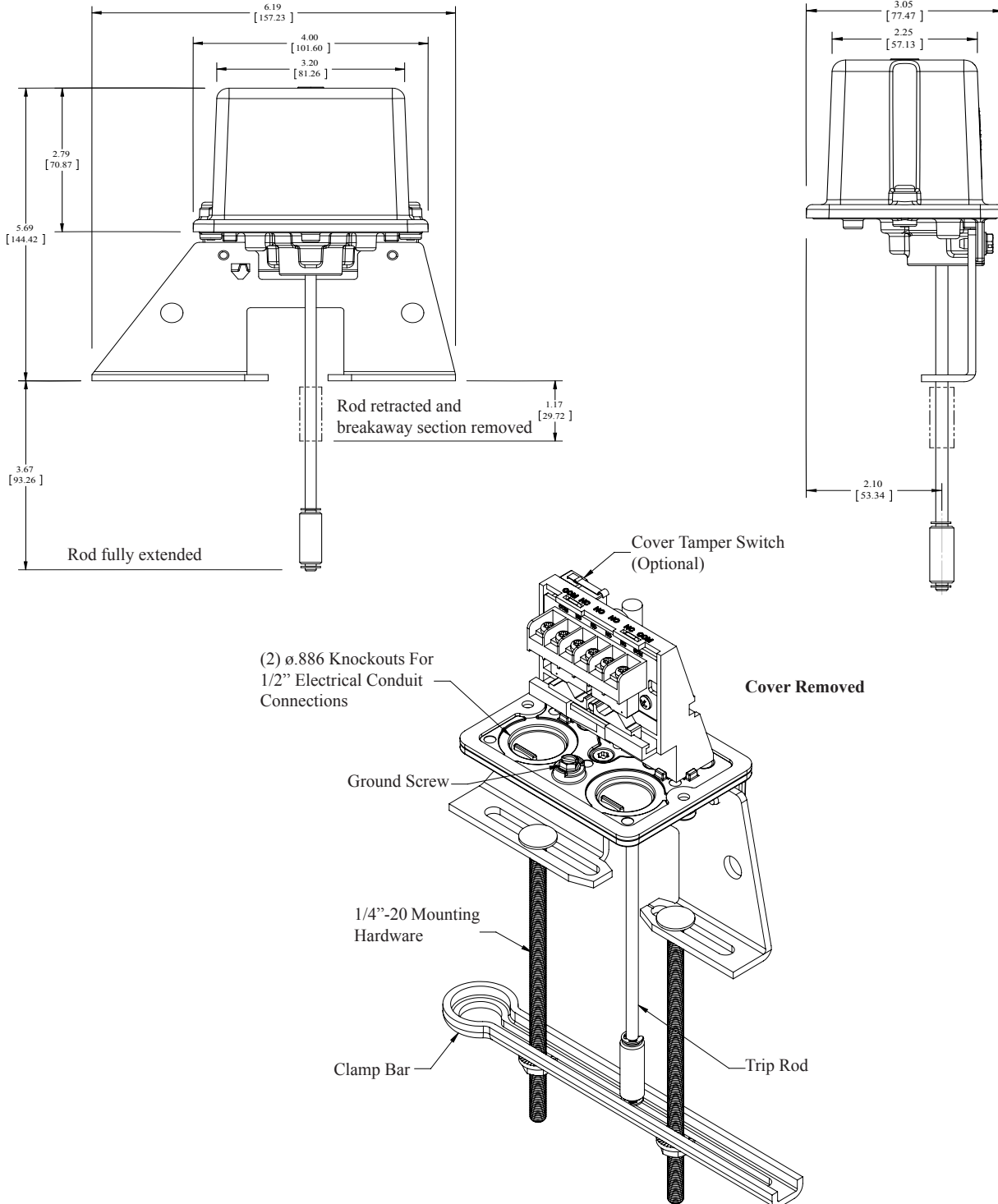

Breaking Excessive Rod Length

Fig 9

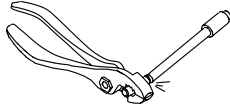

**Switch Terminal Connections
Clamping Plate Terminal**

Fig 10

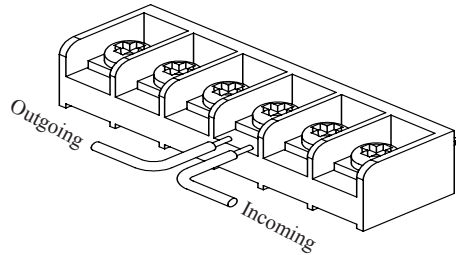

WARNING

An uninsulated section of a single conductor should not be looped around the terminal and serve as two separate connections. The wire must be severed, thereby providing supervision of the connection in the event that the wire become dislodged from under the terminal. Failure to sever the wire may render the device inoperable risking severe property damage and loss of life. Do not strip wire beyond 3/8" of length or expose an uninsulated conductor beyond the edge of the terminal block. When using stranded wire, capture all strands under the clamping plate.

NOTICE

All conduit and connectors selected for the installation of this product shall be suitable for the environment for which it is to be used and shall be installed to the manufacturer's installation instructions. For NEMA 4, 4X, 6, 6P installations, the cover screws are recommended to be tightened to 15 in-lbs minimum and the trip rod locking screw tightened to 5 in-lbs minimum to properly seal the enclosure.

Typical Electrical Connections

Fig 11

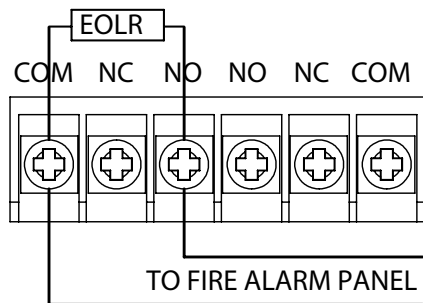

Ordering Information

Model	Description	Stock No.
OSYSU-1	Outside Screw & Yoke Supervisory Switch (Single switch)	1010102
OSYSU-2	Outside Screw & Yoke Supervisory Switch (Double switch)	1010202
OSYSU-2 CRH	Outside Screw & Yoke Supervisory Switch (Double Switch). Corrosion resistant hardware of 316 stainless steel & nickel plated to ASTM B377 Type V Brackets	1010210
	Cover Screw	5490424
	Hex Key for Cover Screws and Installation Adjustments	5250062
	Optional Cover Tamper Switch Kit	0090200

Engineering Specifications: OS&Y Valves

UL, CUL Listed / FM Approved and CE Marked valve supervisory switches shall be furnished and installed on all OS&Y type valves that can be used to shut off the flow of water to any portion of the fire sprinkler system, where indicated on the drawings and plans and as required by applicable local and national codes and standards. The supervisory switch shall be NEMA 4X and 6P rated and capable of being mounted in any position indoors or out and be completely submerged without allowing water to enter the enclosure.. The enclosure shall be held captive by tamper resistant screws. The device shall contain two 1/2" conduit entrances and one or two Single Pole Double Throw (SPDT) switches. There shall be a visual indicator to display the status of the switches. To aid in installation, it shall be possible to make fine adjustments to the position of the switch on the valve without loosening the mounting bracket from the valve. The device shall contain an adjustable length trip rod and roller, the trip rod shall be held captive by a set screw accessible upon removal of the cover. The switch contacts shall be rated at 10A, 125/250VAC and 2A, 30VDC. OS&Y Valve supervisory switch shall be model OSYSU-1 for the single switch model and OSYSU-2 for the two switch model manufactured by Potter Electric Signal Company LLC

Компания «Life Electronics» занимается поставками электронных компонентов импортного и отечественного производства от производителей и со складов крупных дистрибьюторов Европы, Америки и Азии.

С конца 2013 года компания активно расширяет линейку поставок компонентов по направлению коаксиальный кабель, кварцевые генераторы и конденсаторы (керамические, пленочные, электролитические), за счёт заключения дистрибьюторских договоров

Мы предлагаем:

- Конкурентоспособные цены и скидки постоянным клиентам.
- Специальные условия для постоянных клиентов.
- Подбор аналогов.
- Поставку компонентов в любых объемах, удовлетворяющих вашим потребностям.
- Приемлемые сроки поставки, возможна ускоренная поставка.
- Доставку товара в любую точку России и стран СНГ.
- Комплексную поставку.
- Работу по проектам и поставку образцов.
- Формирование склада под заказчика.
- Сертификаты соответствия на поставляемую продукцию (по желанию клиента).
- Тестирование поставляемой продукции.
- Поставку компонентов, требующих военную и космическую приемку.
- Входной контроль качества.
- Наличие сертификата ISO.

В составе нашей компании организован Конструкторский отдел, призванный помогать разработчикам, и инженерам.

Конструкторский отдел помогает осуществить:

- Регистрацию проекта у производителя компонентов.
- Техническую поддержку проекта.
- Защиту от снятия компонента с производства.
- Оценку стоимости проекта по компонентам.
- Изготовление тестовой платы монтаж и пусконаладочные работы.



Тел: +7 (812) 336 43 04 (многоканальный)
Email: org@lifeelectronics.ru