

18W AccuSwitch™ Quasi-Resonant PWM Controller with Integrated Power BJT for >5V Applications

1 Description

The iW1819 integrates a high performance AC/DC power supply controller using digital control technology and a power BJT switch in one package to enable compact peak current mode PWM flyback power supplies. The device operates in quasi-resonant mode and features multiple key protection features, allowing designs with improved efficiency and lower EMI, while lowering the bill of material cost.

The iW1819 features a distinctive soft-start scheme, which allows for fast and yet smooth start-up with both small and large capacitive loads. It removes the need for a secondary feedback circuit while achieving excellent line and load regulation. It also eliminates the need for loop compensation components while maintaining stability across all operating conditions. The pulse-by-pulse waveform analysis allows for fast dynamic load response. The built-in power limit function enables optimized transformer design for a wide input voltage range.

Dialog's innovative, proprietary technology ensures that power supplies built with the iW1819 can achieve both the highest average efficiency and less than 30mW no-load power consumption. And, the iW1819 can start-up into a wide range of capacitive loads at voltages greater than 5V, making it ideal for networking, set-top box and home appliance power supply applications. For 5V applications, please see the iW1820.

2 Features

- Optimized for 12V/1.5AAC/DC adapters with < 30mW no-load power consumption at 230V_{AC} and fast dynamic response
- **AccuSwitch™** technology – integrated 800V bipolar junction transistor (BJT)
- Adaptively controlled soft-start enables fast and smooth start-up for a wide range of capacitive loads (from 330µF to 6,000µF)
- Very tight constant voltage and constant current regulation over entire operating range
- **PrimAccurate™** primary-side feedback eliminates optocoupler and simplifies design
- **EZ-EMI®** design enhances manufacturability
- Intrinsically low common mode noise
- Optimized 72kHz maximum PWM switching frequency achieves best size and efficiency
- Adaptive multi-mode PWM/PFM control improves efficiency
- Quasi-resonant operation for highest overall efficiency
- Dynamic base current control
- No external loop compensation components required
- Built-in single-point protections against output short-circuit, output low impedance, and output overvoltage
- Built-in over-temperature protection (OTP)
- No audible noise over entire operating range

3 Applications

- Network power adapters for ADSL, wireless access
- AC/DC adaptor for set top box
- AC/DC power supplies for home appliances and industrial applications

iW1819

18W AccuSwitch™ Quasi-Resonant PWM Controller with Integrated Power BJT for >5V Applications

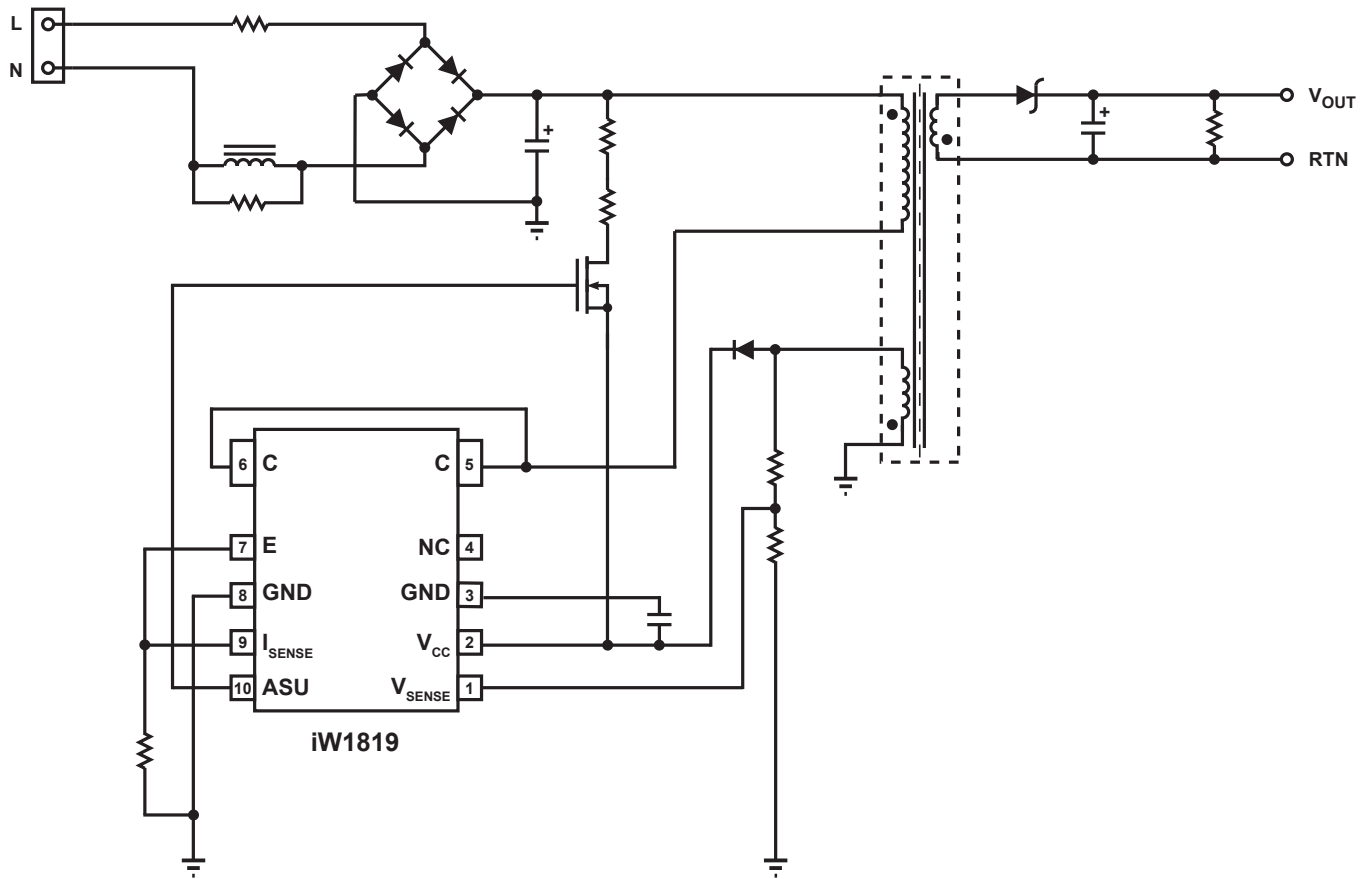

Figure 3.1 : iW1819 Typical Application Circuit

WARNING:

The iW1819 is intended for high voltage AC/DC offline applications. Contact with live high voltage offline circuits or improper use of components may cause lethal or life threatening injuries or property damage. Only qualified professionals with safety training and proper precaution should operate with high voltage offline circuits.

iW1819 Output Power Table at Universal Input (85V_{AC}–264V_{AC})

Condition	Open Frame ¹
Output Power (W) ²	18

Notes:

- Note 1. Maximum practical continuous output power measured at open frame ambient temperature of 50°C while minimum bulk capacitor voltage is kept above 90V (test unit is placed in a non-ventilated environment).
- Note 2. The output power can vary depending on the power supply system designs and operating conditions.

18W AccuSwitch™ Quasi-Resonant PWM Controller with Integrated Power BJT for >5V Applications

4 Pinout Description

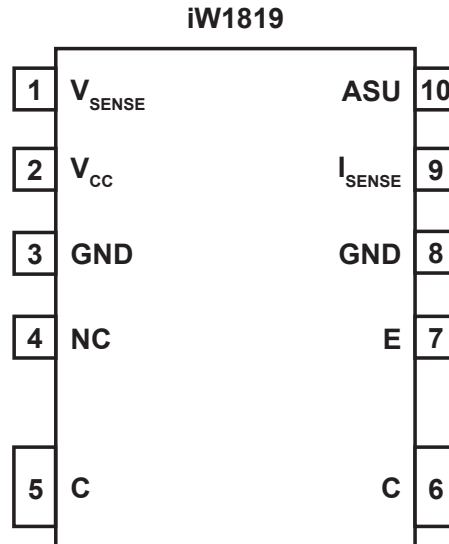

Figure 4.1 : 10-Lead SOIC Batwing Package

Pin Number	Pin Name	Type	Pin Description
1	V _{SENSE}	Analog Input	Auxiliary voltage sense (used for primary-side regulation).
2	V _{CC}	Power Input	Power supply for control logic.
3	GND	Ground	Ground.
4	NC		
5	C	BJT Collector	Collector of internal BJT.
6	C	BJT Collector	Collector of internal BJT.
7	E	BJT Emitter	Emitter of internal BJT.
8	GND	Ground	Ground.
9	I _{SENSE}	Analog Input	Primary current sense. Used for cycle-by-cycle peak current control and current limit.
10	ASU	Output	Control signal. Used for active start-up device.

18W AccuSwitch™ Quasi-Resonant PWM Controller with Integrated Power BJT for >5V Applications

5 Absolute Maximum Ratings

Absolute maximum ratings are the parameter values or ranges which can cause permanent damage if exceeded.

Parameter	Symbol	Value	Units
DC supply voltage range (pin 2, $I_{CC} = 20\text{mA max}$)	V_{CC}	-0.3 to 25.0	V
Continuous DC supply current at V_{CC} pin ($V_{CC} = 15\text{V}$)	I_{CC}	25	mA
ASU output (pin 10)		-0.3 to 19.0	V
V_{SENSE} input (pin 1, $I_{VSENSE} \leq 10\text{mA}$)		-0.7 to 4.0	V
I_{SENSE} input (pin 9)		-0.3 to 4.0	V
Collector-Base breakdown voltage	V_{CBO}	800	V
Collector current (Note 1)	I_C	4	A
Collector peak current (Note 1) ($t_p < 1\text{ms}$)	I_{CM}	8	A
Maximum junction temperature	T_{JMAX}	150	°C
Operating junction temperature	T_{JOPT}	-40 to 150	°C
Storage temperature	T_{STG}	-55 to 150	°C
Electrostatic Discharge Capability (Human Body Model), JEDEC JS-001-2012	$ESD_{(HBM)}$	±2000	V
Electrostatic Discharge Capability (Charged Device Model), JESD22-C101	$ESD_{(CDM)}$	±1000	V
Latch-up test per JESD78D		±100	mA

Notes:

Note 1. Limited by maximum junction temperature.

6 Thermal Characteristics

Parameter	Symbol	Value	Units
Thermal Resistance Junction-to-Ambient ¹	θ_{JA}	55.2	°C/W
Characterization Parameter Junction-to-Collector pin (pin 5 and pin 6) ²	$\Psi_{J-COLLECTOR}$	5.8	°C/W
Thermal Shutdown Threshold ³	T_{SD}	150	°C
Thermal Shutdown Recovery ³	T_{SD-R}	120	°C

Notes:

Note 1. Device is mounted on a 4-layer JEDEC board with 100mm² of 70µm thick copper, in a one-cubic-foot natural convection chamber.

Note 2. $\Psi_{J-COLLECTOR}$ [Psi Junction to Collector pin] provides an estimation of the die junction temperature relative to the Collector pin [internal BJT Collector] surface temperature.

Note 3. These parameters are typical and they are guaranteed by design.

iW1819

18W AccuSwitch™ Quasi-Resonant PWM Controller with Integrated Power BJT for >5V Applications

7 Physical Dimensions

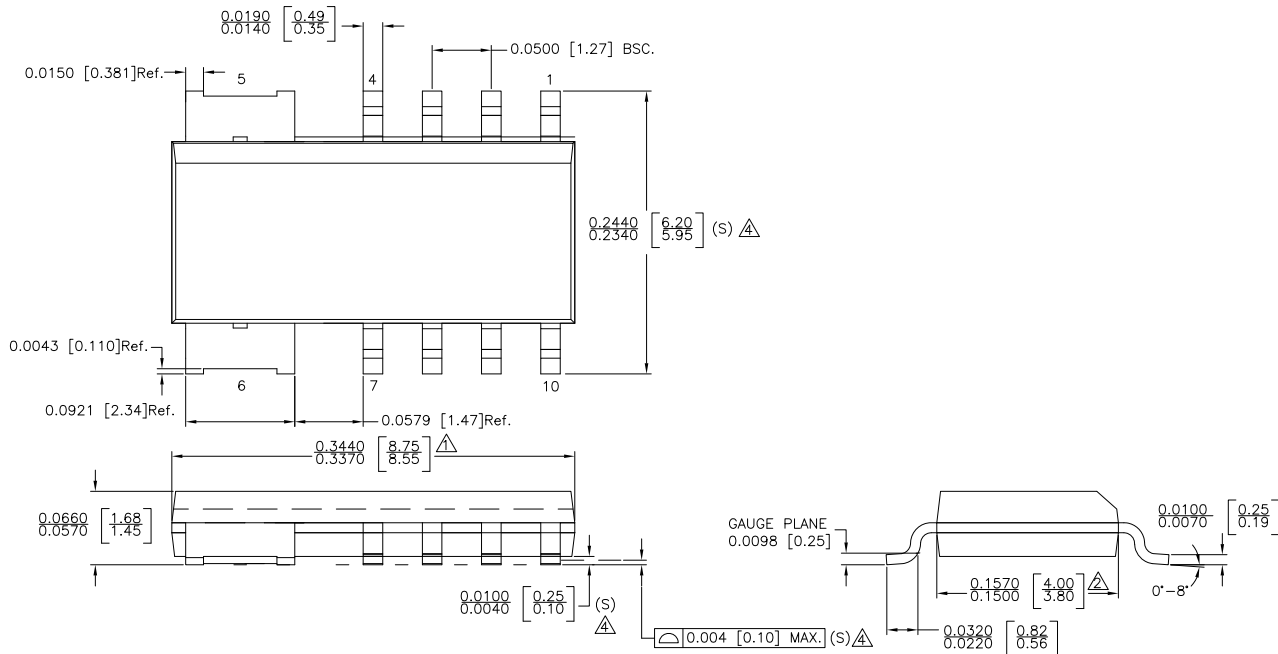

NOTE :

- △ DOES NOT INCLUDE MOLD FLASH, PROTRUSIONS OR GATE BURRS. MOLD FLASH, PROTRUSIONS AND GATE BURRS SHALL NOT EXCEED .006 INCH PER SIDE.
- △ DOES NOT INCLUDE INTER-LEAD FLASH OR PROTRUSIONS. INTER-LEAD FLASH AND PROTRUSIONS SHALL NOT EXCEED .010 INCH PER SIDE.
- 3. THIS PART IS COMPLIANT WITH JEDEC SPECIFICATION MS-012 AB.
- △ LEAD SPAN/STAND OFF HEIGHT/COPLANARITY ARE CONSIDERED AS SPECIAL CHARACTERISTIC(S)
- 5. CONTROL DIMENSIONS IN INECHES.[mm]

STATUS: RELEASED	SCALE: DO NOT SCALE
TERMINAL FINISH: NiPdAu (PPF)	
TITLE: 10 SOIC BATWING PACKAGE OUTLINE	
REV: A	DATE: 29-SEP-2015

8 Ordering Information

Part no.	Options	Package	Description
iW1819-00	Cable Comp = 0mV, OTP recovery threshold = 100°C	SO-10 Batwing	Tape & Reel ¹
iW1819-01	Cable Comp = 150mV, OTP recovery threshold = 100°C	SO-10 Batwing	Tape & Reel ¹
iW1819-11	Cable Comp = 150mV, OTP recovery threshold = 120°C	SO-10 Batwing	Tape & Reel ¹

Note 1: Tape & Reel packing quantity is 2,500/reel. Minimum packing quantity is 2,500.

18W AccuSwitch™ Quasi-Resonant PWM Controller with Integrated Power BJT for >5V Applications

Disclaimer

Information in this document is believed to be accurate and reliable. However, Dialog Semiconductor does not give any representations or warranties, expressed or implied, as to the accuracy or completeness of such information. Dialog Semiconductor furthermore takes no responsibility whatsoever for the content in this document if provided by any information source outside of Dialog Semiconductor.

Dialog Semiconductor reserves the right to change without notice the information published in this document, including without limitation the specification and the design of the related semiconductor products, software and applications.

Applications, software, and semiconductor products described in this document are for illustrative purposes only. Dialog Semiconductor makes no representation or warranty that such applications, software and semiconductor products will be suitable for the specified use without further testing or modification. Unless otherwise agreed in writing, such testing or modification is the sole responsibility of the customer and Dialog Semiconductor excludes all liability in this respect.

Customer notes that nothing in this document may be construed as a license for customer to use the Dialog Semiconductor products, software and applications referred to in this document. Such license must be separately sought by customer with Dialog Semiconductor.

All use of Dialog Semiconductor products, software and applications referred to in this document are subject to [Dialog Semiconductor's Standard Terms and Conditions of Sale](#), available on the company website (www.dialog-semiconductor.com) unless otherwise stated.

Dialog and the Dialog logo are trademarks of Dialog Semiconductor plc or its subsidiaries. All other product or service names are the property of their respective owners.

© 2018 Dialog Semiconductor. All rights reserved.

RoHS Compliance

Dialog Semiconductor's suppliers certify that its products are in compliance with the requirements of Directive 2011/65/EU of the European Parliament on the restriction of the use of certain hazardous substances in electrical and electronic equipment. RoHS certificates from our suppliers are available on request.

Contacting Dialog Semiconductor

United Kingdom (Headquarters)
Dialog Semiconductor (UK) LTD
Phone: +44 1793 757700

Germany
Dialog Semiconductor GmbH
Phone: +49 7021 805-0

The Netherlands
Dialog Semiconductor B.V.
Phone: +31 73 640 8822

Email
info_pcbg@diasemi.com

North America
Dialog Semiconductor Inc.
Phone: +1 408 845 8500

Japan
Dialog Semiconductor K. K.
Phone: +81 3 5769 5100

Taiwan
Dialog Semiconductor Taiwan
Phone: +886 281 786 222

Web site:
www.dialog-semiconductor.com

Hong Kong
Dialog Semiconductor Hong Kong
Phone: +852 2607 4271

Korea
Dialog Semiconductor Korea
Phone: +82 2 3469 8200

China (Shenzhen)
Dialog Semiconductor China
Phone: +86 755 2981 3669

China (Shanghai)
Dialog Semiconductor China
Phone: +86 21 5424 9058

Mouser Electronics

Authorized Distributor

Click to View Pricing, Inventory, Delivery & Lifecycle Information:

[Dialog Semiconductor:](#)

[iW1819-00](#) [iW1819-01](#) [iW1819-11](#)

Компания «Life Electronics» занимается поставками электронных компонентов импортного и отечественного производства от производителей и со складов крупных дистрибьюторов Европы, Америки и Азии.

С конца 2013 года компания активно расширяет линейку поставок компонентов по направлению коаксиальный кабель, кварцевые генераторы и конденсаторы (керамические, пленочные, электролитические), за счёт заключения дистрибьюторских договоров

Мы предлагаем:

- Конкурентоспособные цены и скидки постоянным клиентам.
- Специальные условия для постоянных клиентов.
- Подбор аналогов.
- Поставку компонентов в любых объемах, удовлетворяющих вашим потребностям.
- Приемлемые сроки поставки, возможна ускоренная поставка.
- Доставку товара в любую точку России и стран СНГ.
- Комплексную поставку.
- Работу по проектам и поставку образцов.
- Формирование склада под заказчика.
- Сертификаты соответствия на поставляемую продукцию (по желанию клиента).
- Тестирование поставляемой продукции.
- Поставку компонентов, требующих военную и космическую приемку.
- Входной контроль качества.
- Наличие сертификата ISO.

В составе нашей компании организован Конструкторский отдел, призванный помогать разработчикам, и инженерам.

Конструкторский отдел помогает осуществить:

- Регистрацию проекта у производителя компонентов.
- Техническую поддержку проекта.
- Защиту от снятия компонента с производства.
- Оценку стоимости проекта по компонентам.
- Изготовление тестовой платы монтаж и пусконаладочные работы.



Тел: +7 (812) 336 43 04 (многоканальный)
Email: org@lifeelectronics.ru