

IS31AP2010B

3W@5.0V MONO FILTER-LESS, CLASS-D AUDIO POWER AMPLIFIER

AUGUST 2011

GENERAL DESCRIPTION

The IS31AP2010B is a high efficiency, 3W@5.0V mono filter-less class-D audio power amplifier. A low noise, filter-less PWM architecture eliminates the output filter, reduces external component count, system cost, and simplifying design.

Operating in a single 5.0V supply, IS31AP2010B is capable of driving 4Ω speaker load at a continuous average output of 3W@10% THD+N. The IS31AP2010B has high efficiency with speaker load compared to a typical class- AB amplifier.

In cellular handsets, the earpiece, speaker phone, and melody ringer speaker can each be driven by the IS31AP2010B. The gain of IS31AP2010B is externally configurable which allows independent gain control from multiple sources by summing signals from each function.

IS31AP2010B is available in UTQFN-9 packages. It operates from 2.7V to 5.5V over the temperature range of -40°C to +85°C.

FEATURES

- 5.0V supply at THD+N = 10%
- -3W into 4Ω (Typ.)
- -1.68W into 8Ω (Typ.)
- Efficiency at 5.0V
- -85% at 400mW with a 4Ω speaker
- -88% at 400mW with a 8Ω speaker
- Less than 1μA shutdown current
- Optimized PWM output stage eliminates LC output filter
- Fully differential design reduces RF rectification and eliminates bypass capacitor
- Improved CMRR eliminates two input coupling capacitors
- Integrated click-and-pop suppression circuitry
- UTQFN-9 package
- RoHS compliant and 100% lead(Pb)-free

APPLICATIONS

- Wireless or cellular handsets and PDAs
- Portable DVD player
- Notebook PC
- Portable radio
- Educational toys
- Portable gaming

TYPICAL APPLICATION CIRCUIT

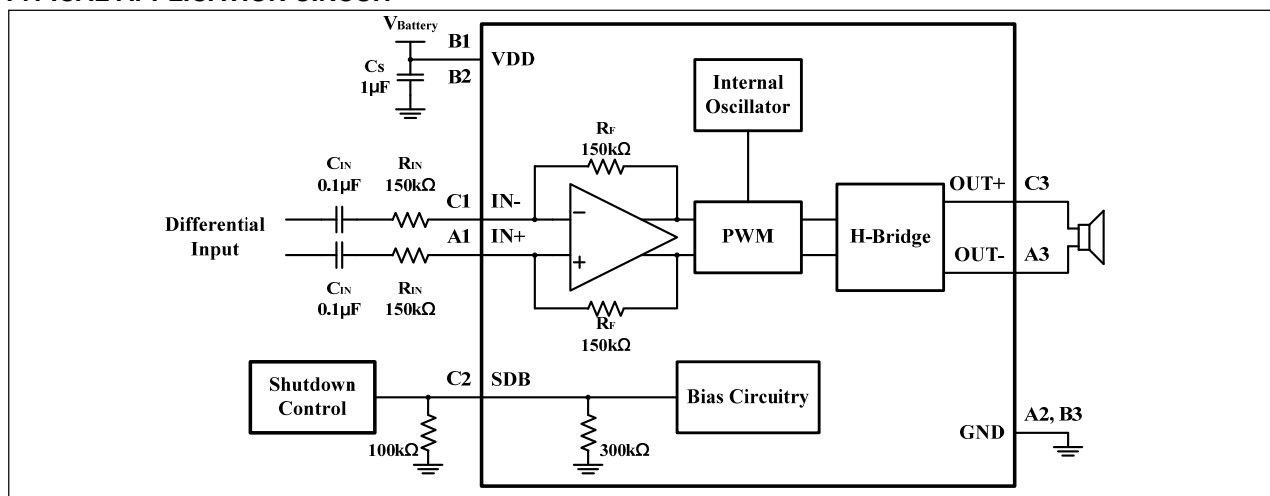

Figure 1 Typical Application Circuit

Copyright © 2011 Integrated Silicon Solution, Inc. All rights reserved. ISSI reserves the right to make changes to this specification and its products at any time without notice. ISSI assumes no liability arising out of the application or use of any information, products or services described herein. Customers are advised to obtain the latest version of this device specification before relying on any published information and before placing orders for products.

Integrated Silicon Solution, Inc. does not recommend the use of any of its products in life support applications where the failure or malfunction of the product can reasonably be expected to cause failure of the life support system or to significantly affect its safety or effectiveness. Products are not authorized for use in such applications unless Integrated Silicon Solution, Inc. receives written assurance to its satisfaction, that:

- a.) the risk of injury or damage has been minimized;
- b.) the user assume all such risks; and
- c.) potential liability of Integrated Silicon Solution, Inc is adequately protected under the circumstances

IS31AP2010B

PIN CONFIGURATION

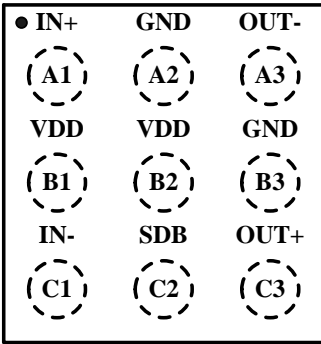
Package	Pin Configuration (Top View)
UTQFN-9	

PIN DESCRIPTION

No.	Pin	I/O	Description
A1	IN+	I	Positive audio input.
A2, B3	GND	-	Connect to ground.
A3	OUT-	O	Negative audio output.
B1, B2	VDD	-	Power supply.
C1	IN-	I	Negative audio input.
C2	SDB	I	Enter in shutdown mode when active low.
C3	OUT+	O	Positive audio output.

ORDERING INFORMATION

Industrial Range: -40°C to +85°C

Order Part No.	Package	QTY/Reel
IS31AP2010B-UTLS2-TR	UTQFN-9, Lead-free	3000

IS31AP2010B

ABSOLUTE MAXIMUM RATINGS (NOTE 1)

Supply voltage, V_{DD}	-0.3V ~ +5.5V
Voltage at any input pin	-0.3V ~ $V_{DD} + 0.3V$
Junction temperature, T_{JMAX}	-40°C ~ +150°C
Storage temperature rang, T_{stg}	-65°C ~ +150°C
Lead temperature 1.6mm(1/16 inch) from case for 10s	- 260°C
Thermal resistance θ_{JA} (UTQFN)	70°C/W
ESD (HBM)	6kV

ELECTRICAL CHARACTERISTICS

$V_{DD} = 2.7V \sim 5.5V$, $T_A = 25^\circ C$, unless otherwise noted. (Note 2)

Symbol	Parameter	Condition	Min.	Typ.	Max.	Unit
V_{DD}	Supply voltage		2.7		5.5	V
V _{OS}	Output offset voltage (measured differentially)	$V_{SDB} = 0V$, $A_V = 2V/V$		10		mV
I_{DD}	Quiescent current	$V_{DD} = 5.5V$, no load		2.6		mA
		$V_{DD} = 2.7V$, no load		1.2		
I_{SD}	Shutdown current	$V_{SDB} = 0.4V$			1	μA
f_{sw}	Switching frequency			250		kHz
R_{IN}	Input resistor	Gain $\leq 20V/V$	15			kΩ
Gain		$R_{IN} = 150k\Omega$		2		V/V
V_{IH}	High-level input voltage		1.4		V_{DD}	V
V_{IL}	Low-level input voltage		0		0.4	V

IS31AP2010B

ELECTRICAL CHARACTERISTICS

$T_A = 25^\circ\text{C}$, Gain = 2V/V, $C_{IN} = 2\mu\text{F}$, unless otherwise noted. (Note 3)

Symbol	Parameter	Condition	Min.	Typ.	Max.	Unit	
P_O	Output power	THD+N = 10% $f = 1\text{kHz}$, $R_L = 8\Omega$	$V_{DD} = 5.0\text{V}$		1.68		W
			$V_{DD} = 4.2\text{V}$		1.2		
			$V_{DD} = 3.6\text{V}$		0.88		
		THD+N = 10% $f = 1\text{kHz}$, $R_L = 4\Omega$	$V_{DD} = 5.0\text{V}$		3.0		W
			$V_{DD} = 4.2\text{V}$		2.0		
			$V_{DD} = 3.6\text{V}$		1.5		
		THD+N = 1% $f = 1\text{kHz}$, $R_L = 8\Omega$	$V_{DD} = 5.0\text{V}$		1.4		W
			$V_{DD} = 4.2\text{V}$		1.0		
			$V_{DD} = 3.6\text{V}$		0.7		
		THD+N = 1% $f = 1\text{kHz}$, $R_L = 4\Omega$	$V_{DD} = 5.0\text{V}$		2.4		W
			$V_{DD} = 4.2\text{V}$		1.68		
			$V_{DD} = 3.6\text{V}$		1.2		
THD+N	Total harmonic distortion plus noise	$V_{DD} = 4.2\text{V}$, $P_O = 0.6\text{W}$, $R_L = 8\Omega$, $f = 1\text{kHz}$		0.18		%	
		$V_{DD} = 4.2\text{V}$, $P_O = 1.1\text{W}$, $R_L = 4\Omega$, $f = 1\text{kHz}$		0.22			
V_{NO}	Output voltage noise	$V_{DD} = 4.2\text{V}$, $f = 20\text{Hz}$ to 20kHz Inputs AC-grounded		80		μVrms	
T_{WU}	Wake-up time from shutdown	$V_{DD} = 3.6\text{V}$		32		ms	
SNR	Signal-to-noise ratio	$P_O = 1.0\text{W}$, $R_L = 8\Omega$, $V_{DD} = 4.2\text{V}$		91		dB	
PSRR	Power supply rejection ratio	$f = 217\text{Hz}$, $R_L = 8\Omega$ Input grounded	$V_{DD} = 5.0\text{V}$		-75	dB	
			$V_{DD} = 4.2\text{V}$		-70		
			$V_{DD} = 3.6\text{V}$		-66		

Note:

1. Stresses beyond those listed under absolute maximum ratings may cause permanent damage to the device. These are stress ratings only, and functional operation of the device at these or any other conditions beyond those indicated under recommended operating conditions is not implied. Exposure to absolute-maximum-rated conditions for extended periods may affect device reliability.
2. All parts are production tested at $T_A = 25^\circ\text{C}$. Other temperature limits are guaranteed by design.
3. Guaranteed by design.

IS31AP2010B

TYPICAL PERFORMANCE CHARACTERISTIC

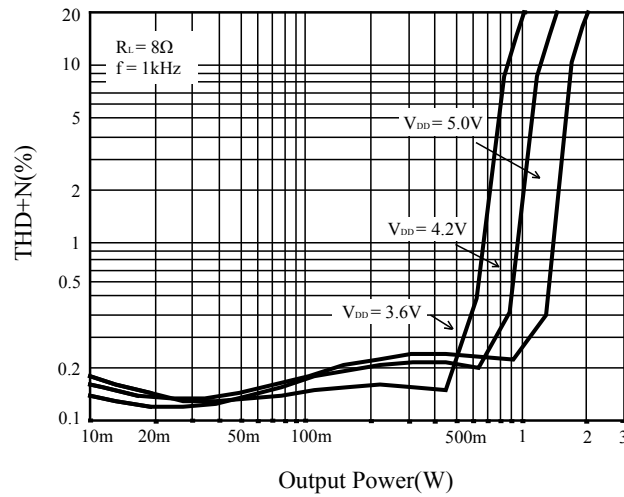

Figure 2 THD+N vs. Output Power

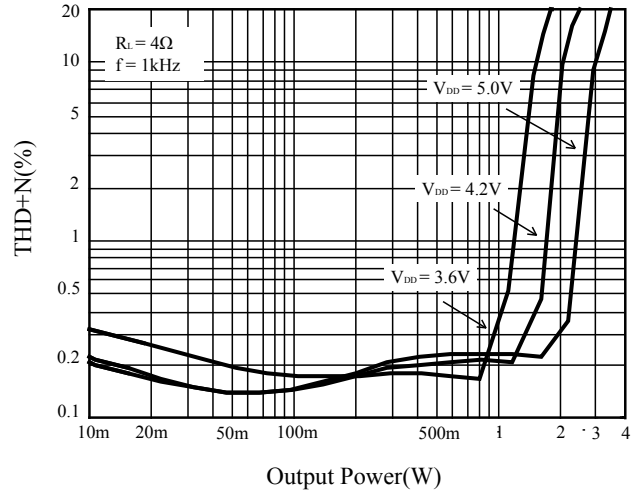

Figure 3 THD+N vs. Output Power

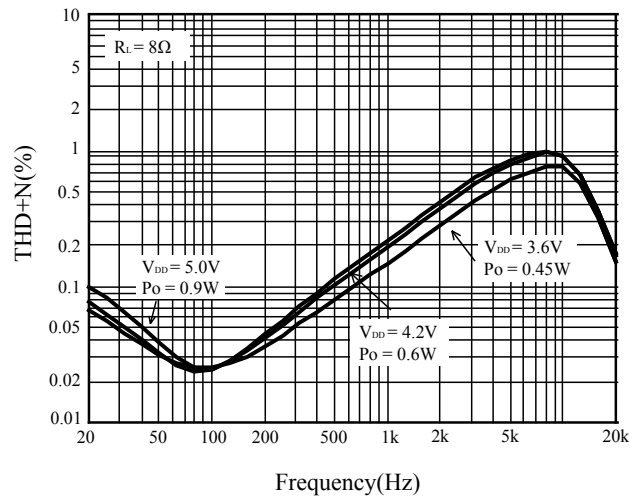

Figure 4 THD+N vs. Frequency

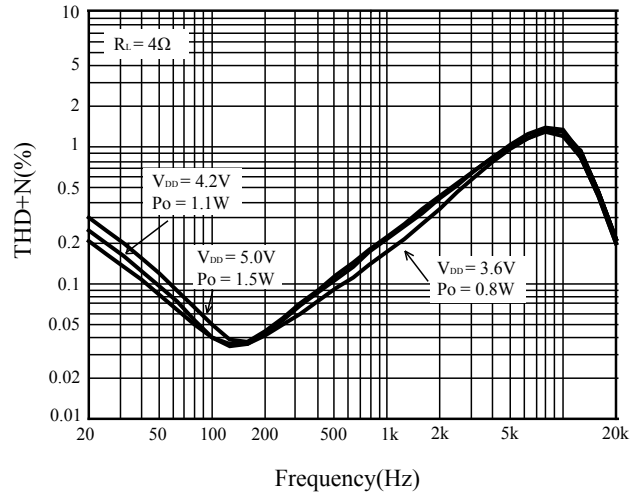

Figure 5 THD+N vs. Frequency

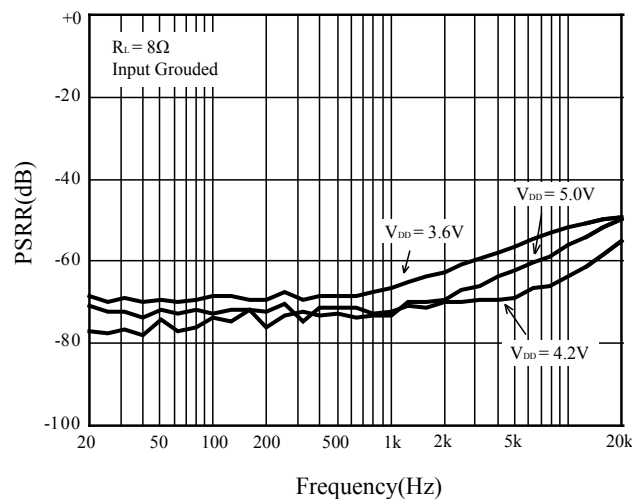

Figure 6 PSRR vs. Frequency

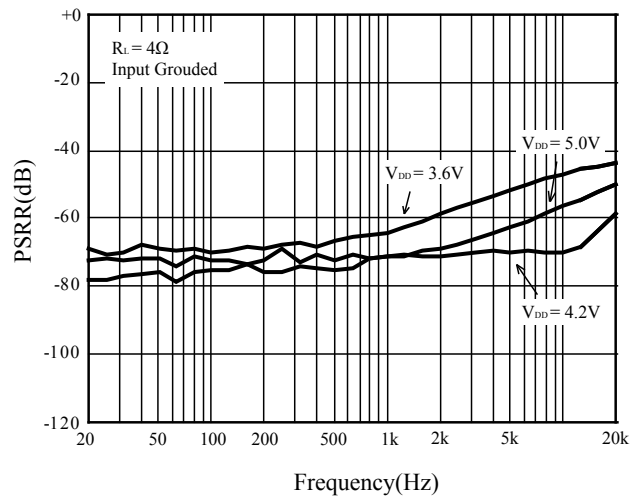

Figure 7 PSRR vs. Frequency

IS31AP2010B

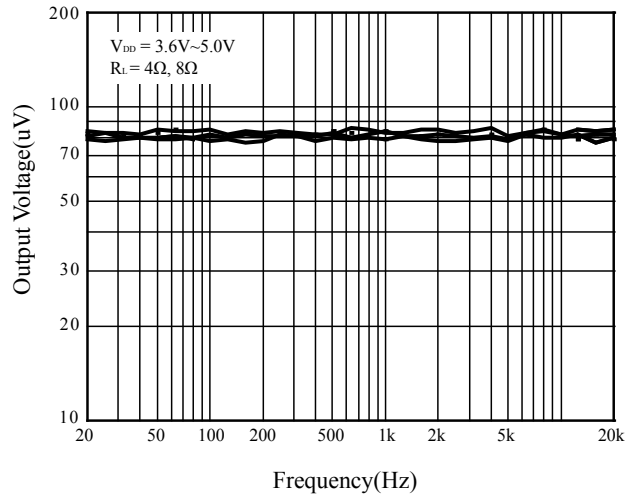

Figure 8 Noise

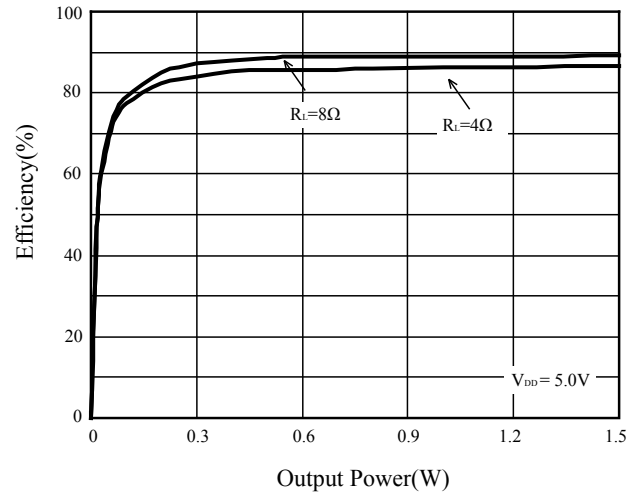

Figure 9 Efficiency

IS31AP2010B

APPLICATION INFORMATION

Fully Differential Amplifier

The IS31AP2010B is a fully differential amplifier with differential inputs and outputs. The fully differential amplifier consists of a differential amplifier and a common mode amplifier. The differential amplifier ensures that the amplifier outputs a differential voltage on the output that is equal to the differential input times the gain. The common-mode feedback ensures that the common-mode voltage at the output is biased around $V_{DD}/2$ regardless of the common-mode voltage at the input. The fully differential IS31AP2010B can still be used with a single-ended input; however, the IS31AP2010B should be used with differential inputs when in a noisy environment, like a wireless handset, to ensure maximum noise rejection.

Advantages of Fully Differential Amplifiers

The fully differential amplifier does not require a bypass capacitor. This is because any shift in the mid-supply affects both positive and negative channels equally and cancels at the differential output.

GSM handsets save power by turning on and shutting off the RF transmitter at a rate of 217Hz. The transmitted signal is picked-up on input and output traces. The fully differential amplifier cancels the signal much better than the typical audio amplifier.

Component Selection

Figure 10 shows the IS31AP2010B with differential inputs and input capacitors, and Figure 11 shows the IS31AP2010B with single-ended inputs. Differential inputs should be used whenever possible because the single-ended inputs are much more susceptible to noise.

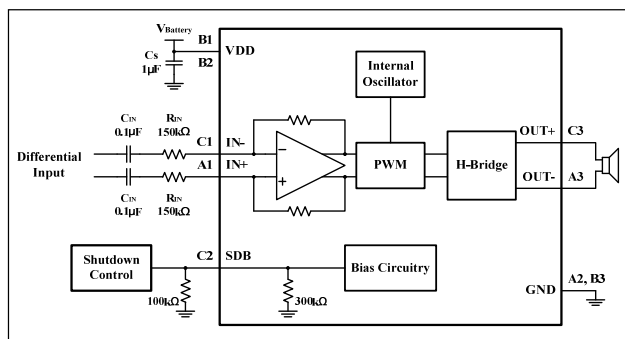

Figure 10 Differential Input

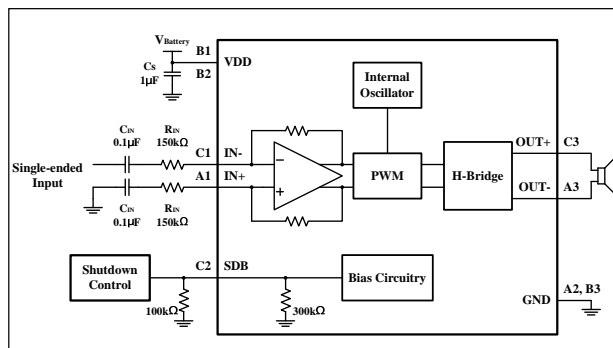

Figure 11 Single-Ended Input

Input Resistors (R_{IN})

The input resistors (R_{IN}) set the gain of the amplifier according to Equation (1).

$$Gain = \frac{2 \times R_F}{R_{IN}} \left(\frac{V}{V} \right) \quad (1)$$

Resistor matching is very important in fully differential amplifiers. The balance of the output on the reference voltage depends on matched ratios of the resistors. CMRR, PSRR, and cancellation of the second harmonic distortion diminish if resistor mismatch occurs. Therefore, it is recommended to use 1% tolerance resistors or better to keep the performance optimized. Matching is more important than overall tolerance. Resistor arrays with 1% matching can be used with a tolerance greater than 1%.

Place the input resistors very close to the IS31AP2010B to limit noise injection on the high-impedance nodes.

For optimal performance the gain should be set to 2V/V or lower. Lower gain allows the IS31AP2010B to operate at its best, and keeps a high voltage at the input making the inputs less susceptible to noise.

Decoupling Capacitor (C_S)

The IS31AP2010B is a high performance class-D audio amplifier that requires adequate power supply decoupling to ensure the efficiency is high and total harmonic distortion (THD) is low. For higher frequency transients, spikes, or digital hash on the line, a good low equivalent-series-resistance (ESR) ceramic capacitor, typically 1μF, placed as close as possible to the device VDD lead works best. Placing this decoupling capacitor close to the IS31AP2010B is very important for the efficiency of the class-D amplifier, because any resistance or inductance in the trace between the device and the capacitor can cause a loss in efficiency. For filtering lower frequency noise signals, a 10μF or greater capacitor placed near the audio power amplifier would also help, but it is not required in most applications because of the high PSRR of this device

IS31AP2010B

Input Capacitors (C_{IN})

The input capacitors and input resistors form a high pass filter with the corner frequency, f_c , determined in Equation (2).

$$f_c = \frac{1}{(2\pi R_{IN} C_{IN})} \quad (2)$$

The value of the input capacitor is important to consider as it directly affects the bass (low frequency) performance of the circuit. Speakers in wireless phones cannot usually respond well to low frequencies, so the corner frequency can be set to block low frequencies in this application. Equation (3) is reconfigured to solve for the input coupling capacitance.

$$C_{IN} = \frac{1}{(2\pi R_{IN} f_c)} \quad (3)$$

If the corner frequency is within the audio band, the capacitors should have a tolerance of $\pm 10\%$ or better, because any mismatch in capacitance causes an impedance mismatch at the corner frequency and below.

For a flat low frequency response, use large input coupling capacitors (1 μ F). However, in a GSM phone the ground signal is fluctuating at 217Hz, but the signal from the codec does not have the same 217Hz fluctuation. The difference between the two signals is amplified, sent to the speaker, and heard as a 217Hz hum.

Summing Input Signals

Most wireless phones or PDAs need to sum signals at the audio power amplifier or just have two signal sources that need separate gain. The IS31AP2010B makes it easy to sum signals or use separate signal sources with different gains. Many phones now use the same speaker for the earpiece and ringer, where the wireless phone would require a much lower gain for the phone earpiece than for the ringer. PDAs and phones that have stereo headphones require summing of the right and left channels to output the stereo signal to the mono speaker.

Summing Two Differential Input Signals

Two extra resistors are needed for summing differential signals (a total of 5 components). The gain for each input source can be set independently (see Equations (4) and (5) and Figure 12).

$$Gain1 = \frac{V_O}{V_{I1}} = \frac{2 \times R_F}{R_{IN1}} \left(\frac{V}{V} \right) \quad (4)$$

$$Gain2 = \frac{V_O}{V_{I2}} = \frac{2 \times R_F}{R_{IN2}} \left(\frac{V}{V} \right) \quad (5)$$

If summing left and right inputs with a gain of 1V/V, use $R_{IN1} = R_{IN2} = 300k\Omega$.

If summing a ring tone and a phone signal, set the ring-tone gain to $Gain2 = 2V/V$, and the phone gain to $Gain1 = 0.1V/V$. The resistor values would be $R_{IN1} = 3M\Omega$, $R_{IN2} = 150k\Omega$

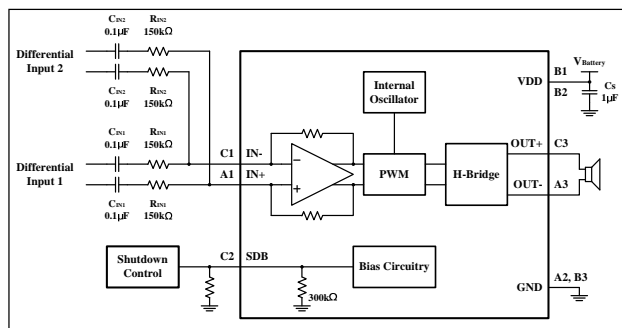

Figure 12 Summing Two Differential Inputs

Summing a Differential Input Signal and a Single-Ended Input Signal

Figure 13 shows how to sum a differential input signal and a single-ended input signal. Ground noise may couple in through IN- with this method. It is better to use differential inputs. The corner frequency of the single-ended input is set by C_{IN2} , shown in Equation (8). To assure that each input is balanced, the single-ended input must be driven by a low-impedance source even if the input is not in use.

$$Gain1 = \frac{V_O}{V_{I1}} = \frac{2 \times R_F}{R_{IN1}} \left(\frac{V}{V} \right) \quad (6)$$

$$Gain2 = \frac{V_O}{V_{I2}} = \frac{2 \times R_F}{R_{IN2}} \left(\frac{V}{V} \right) \quad (7)$$

$$C_{IN2} = \frac{1}{(2\pi R_{IN2} f_c)} \quad (8)$$

If summing a ring tone and a phone signal, the phone signal should use a differential input signal while the ring tone might be limited to a single-ended signal. Phone gain is set at $Gain1 = 0.1V/V$, and the ring-tone gain is set to $Gain2 = 2V/V$, the resistor values would be

$R_{IN1} = 3M\Omega$, $R_{IN2} = 150k\Omega$

The high pass corner frequency of the single-ended input is set by C_{IN2} . If the desired corner frequency is less than 20Hz.

$$C_{IN2} > \frac{1}{(2\pi 150k\Omega \times 20Hz)} \quad (9)$$

$$C_{IN2} > 53 pF \quad (10)$$

IS31AP2010B

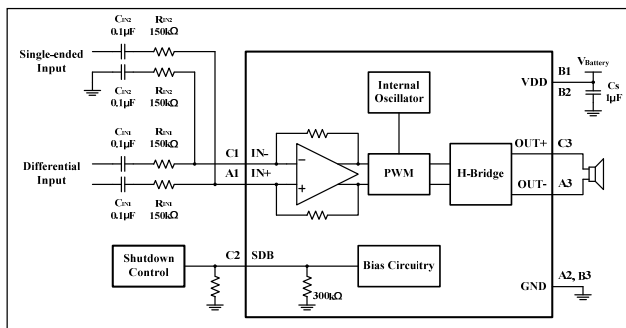

Figure 13 Summing Differential Input and Single-Ended Input Signals

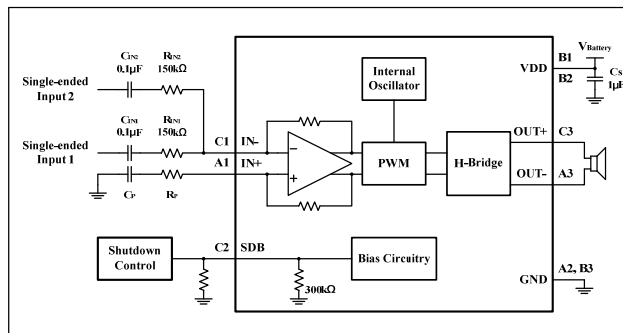

Figure 14 Summing Two Single-Ended Inputs

Summing Two Single-Ended Input Signals

The gain and corner frequencies (f_{c1} and f_{c2}) for each input source can be set independently (see Equations (11) through (14) and Figure 14). Resistor, R_p , and capacitor, C_p , are needed on the $IN-$ terminal to match the impedance on the $IN+$ terminal. The single-ended inputs must be driven by low impedance sources even if one of the inputs is not outputting an ac signal.

$$Gain1 = \frac{V_O}{V_{I1}} = \frac{2 \times R_F}{R_{IN1}} \left(\frac{V}{V} \right) \quad (11)$$

$$Gain2 = \frac{V_O}{V_{I2}} = \frac{2 \times R_F}{R_{IN2}} \left(\frac{V}{V} \right) \quad (12)$$

$$C_{IN1} = \frac{1}{(2\pi R_{IN1} f_{c1})} \quad (13)$$

$$C_{IN2} = \frac{1}{(2\pi R_{IN2} f_{c2})} \quad (14)$$

$$C_p = C_{IN1} + C_{IN2} \quad (15)$$

$$R_p = \frac{R_{IN1} \times R_{IN2}}{(R_{IN1} + R_{IN2})} \quad (16)$$

EMI Evaluation Result

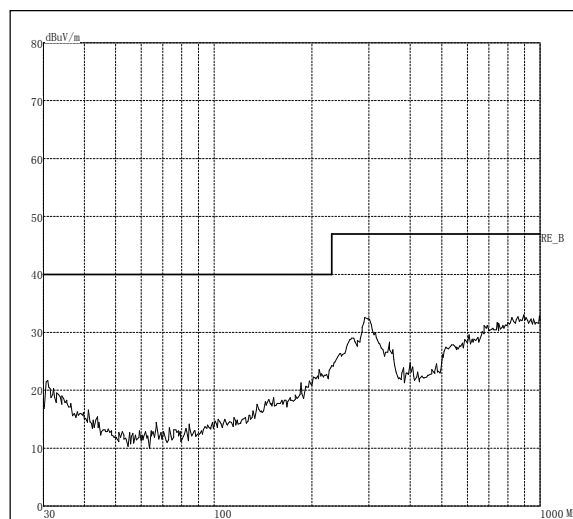

Figure 15 EMI Evaluation Result

IS31AP2010B

CLASSIFICATION REFLOW PROFILES

Profile Feature	Pb-Free Assembly
Preheat & Soak Temperature min (T _{smin}) Temperature max (T _{smax}) Time (T _{smin} to T _{smax}) (t _s)	150°C 200°C 60-120 seconds
Average ramp-up rate (T _{smax} to T _p)	3°C/second max.
Liquidous temperature (T _L) Time at liquidous (t _L)	217°C 60-150 seconds
Peak package body temperature (T _p)*	Max 260°C
Time (t _p)** within 5°C of the specified classification temperature (T _c)	Max 30 seconds
Average ramp-down rate (T _p to T _{smax})	6°C/second max.
Time 25°C to peak temperature	8 minutes max.

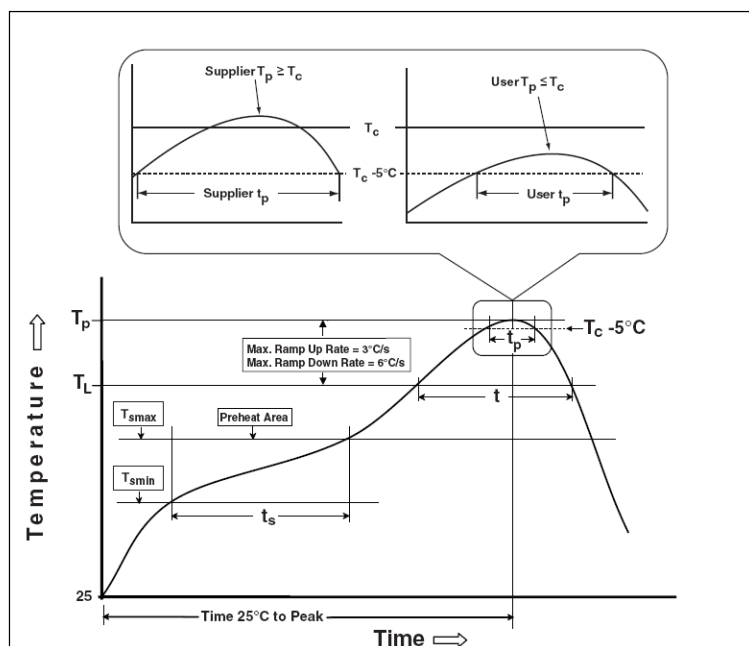
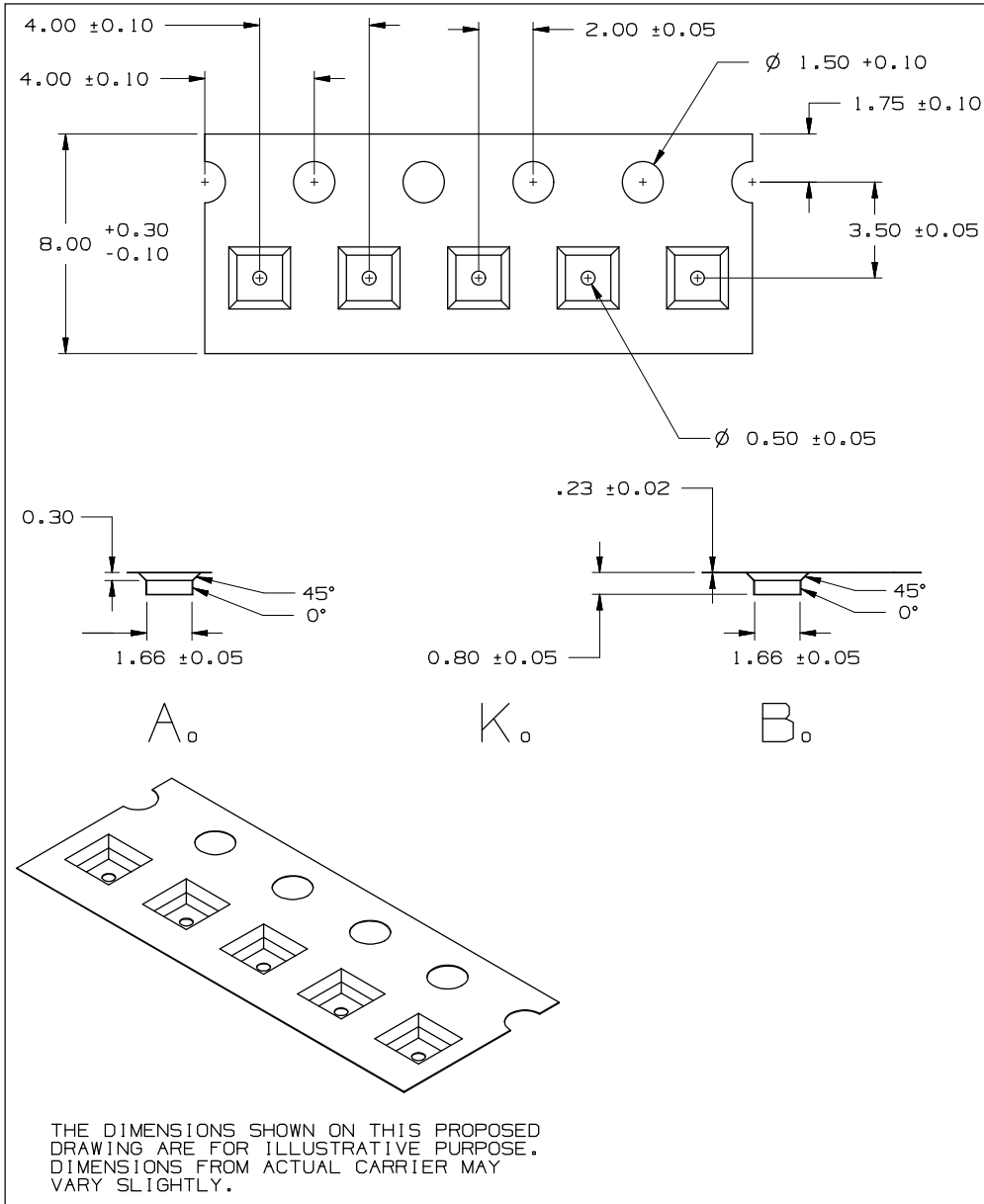

Figure 16 Classification Profile

IS31AP2010B

TAPE AND REEL INFORMATION



Note: All dimensions in millimeters unless otherwise stated.

IS31AP2010B

PACKAGING INFORMATION

UTQFN-9

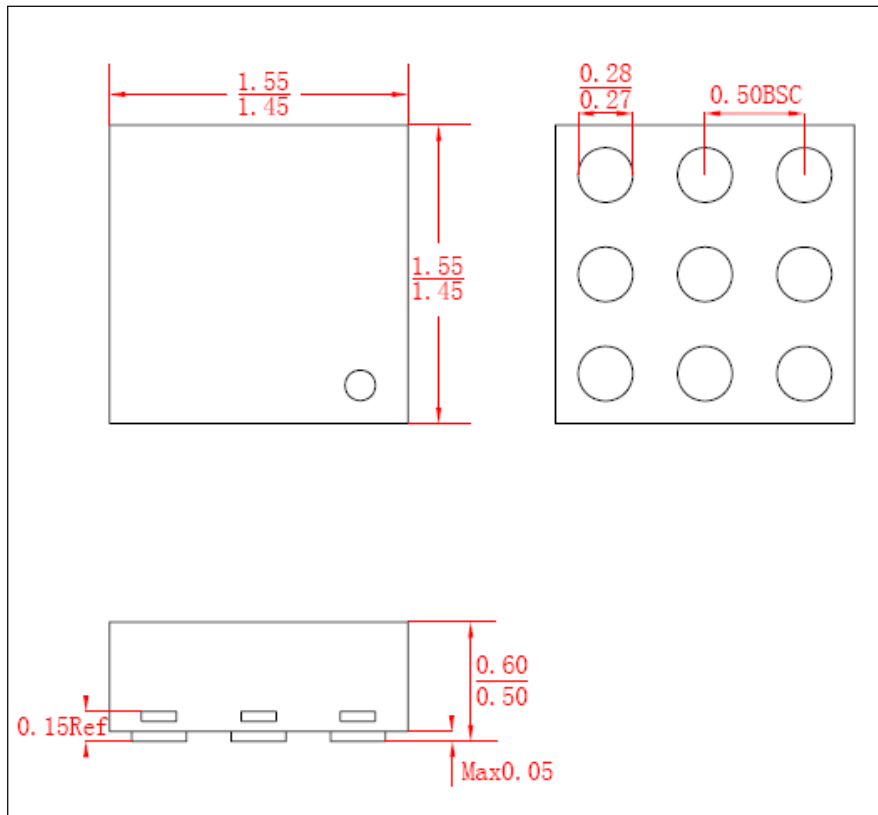

Note: All dimensions in millimeters unless otherwise stated.

Компания «Life Electronics» занимается поставками электронных компонентов импортного и отечественного производства от производителей и со складов крупных дистрибьюторов Европы, Америки и Азии.

С конца 2013 года компания активно расширяет линейку поставок компонентов по направлению коаксиальный кабель, кварцевые генераторы и конденсаторы (керамические, пленочные, электролитические), за счёт заключения дистрибьюторских договоров

Мы предлагаем:

- Конкурентоспособные цены и скидки постоянным клиентам.
- Специальные условия для постоянных клиентов.
- Подбор аналогов.
- Поставку компонентов в любых объемах, удовлетворяющих вашим потребностям.
- Приемлемые сроки поставки, возможна ускоренная поставка.
- Доставку товара в любую точку России и стран СНГ.
- Комплексную поставку.
- Работу по проектам и поставку образцов.
- Формирование склада под заказчика.
- Сертификаты соответствия на поставляемую продукцию (по желанию клиента).
- Тестирование поставляемой продукции.
- Поставку компонентов, требующих военную и космическую приемку.
- Входной контроль качества.
- Наличие сертификата ISO.

В составе нашей компании организован Конструкторский отдел, призванный помогать разработчикам, и инженерам.

Конструкторский отдел помогает осуществить:

- Регистрацию проекта у производителя компонентов.
- Техническую поддержку проекта.
- Защиту от снятия компонента с производства.
- Оценку стоимости проекта по компонентам.
- Изготовление тестовой платы монтаж и пусконаладочные работы.



Тел: +7 (812) 336 43 04 (многоканальный)

Email: org@lifeelectronics.ru