

# Pre-production and sample electric vehicle auxiliary fuses — 500 Vdc, 5-50 A



### Terminal styles

- Ferrule
- Axial bolt-on
- Flush bolt-on
- PCB terminal
- 6.3 mm quick connect
- 6.3 mm reverse quick connect
- 9.5 mm quick connect

### Description

Eaton's Bussmann™ series Electric Vehicle (EV) full range fuses for protecting auxiliary electrical systems up to 500 Vdc in ratings from 20 to 50 amps.

### Ratings

- Volts - 500 Vdc
- Amps
  - 5-50 A
- Interrupting rating
  - Max DC – 20 kA
  - Min DC 135%
- Operating temperature range -40°C to 125°C

### Agency information

- Designed to:
  - JASO D622
  - ISO 8820-8
- Manufactured under a IATF 16949 quality system for compliance with automotive requirements
- RoHS compliant
- REACH declaration available upon request

### Features

- Compact 10x38 mm size is easily mounted with multiple terminal options
- Higher voltage rating provides overall system efficiency using smaller, more economical conductors while meeting the needs of higher voltage battery packs
- Higher interrupting rating protects high capacity battery packs needed for vehicle acceleration and range requirements
- Operation as low as 135% overload provides full range protection for overload and high fault current conditions
- Can be selectively coordinated with upstream battery and charging circuit fuses

### Recommended fuseclip for ferrule fuses

- 1A3400-10-R (see data sheet no. 2131)

**Fuse ratings**

Fuse amps	Average @ 20 kA/500 Vdc		Power loss (W) @ 50%*
	Melting I <sup>2</sup> t	Clearing I <sup>2</sup> t	
20	761	1483	0.49
30	1150	2095	1.10
40	1720	3568	1.96
50	2740	5073	3.06

\* 50 percent of fuse label amp rating tested at 23°C ± 2°C.

**Available pre-production fuse catalog numbers**

Catalog no./terminals				6.3 mm quick connect	6.3 mm reverse quick connect	9.5 mm quick connect	Amps
Ferrule	Axial bolt-on	Flush bolt-on	PCB solder				
XEV10-5	XEV10-5-B	XEV10-5-T	N/A	N/A	N/A	N/A	5
XEV10-7.5	XEV10-7.5-B	XEV10-7.5-T	N/A	N/A	N/A	N/A	7.5
XEV10-10	XEV10-10-B	XEV10-10-T	XEV10-10-1P	XEV10-10-P	XEV10-10-RP	N/A	10
XEV10-20	XEV10-20-B	XEV10-20-T	XEV10-20-1P	XEV10-20-P	XEV10-20-RP	N/A	20
XEV10-30	XEV10-30-B	XEV10-30-T	XEV10-30-1P	XEV10-30-P	XEV10-30-RP	N/A	30
XEV10-40	XEV10-40-B	XEV10-40-T	XEV10-40-1P	XEV10-40-P	XEV10-40-RP	N/A	40
XEV10-50	XEV10-50-B	XEV10-50-T	XEV10-50-1P	XEV10-50-P	XEV10-50-RP	XEV10-50-P9	50

**To order, contact your local Bussmann product sales representative or Bussmann Customer Service**

Phone: 855-BUSSMANN (855-287-7626) M—F, 7:00 a.m. — 6:00 p.m., Central time

Email: [BussCustSat@Eaton.com](mailto:BussCustSat@Eaton.com)

For information on production fuses, contact your local Bussmann product sales representative.

**Dimensions† — mm (nominal values)**

**10x38 mm ferrule**



**6.3 mm quick connect**



**10x38 mm axial bolt-on**

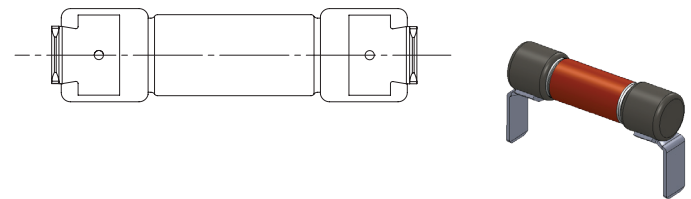

**6.3 mm reverse quick connect**

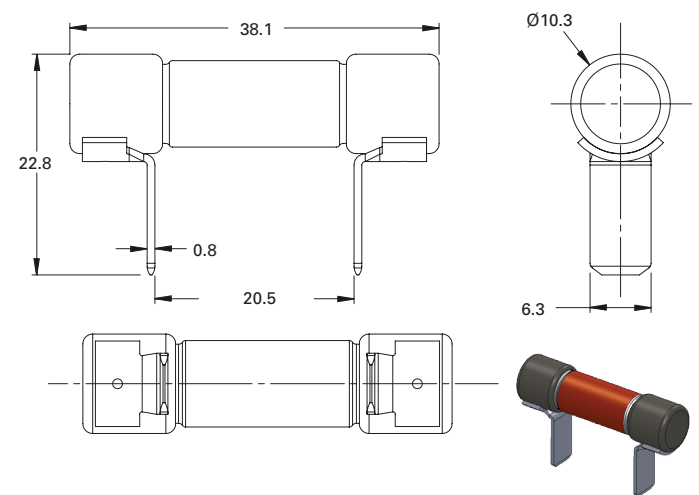

**10x38 mm flush bolt-on**

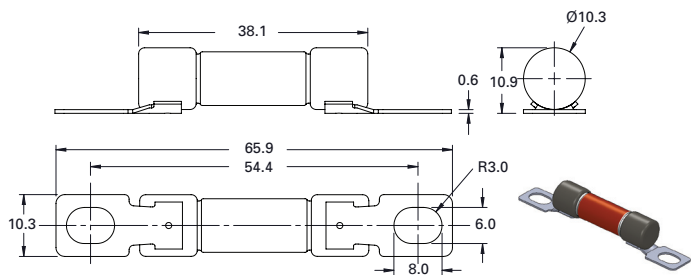

**9.5 mm quick connect**

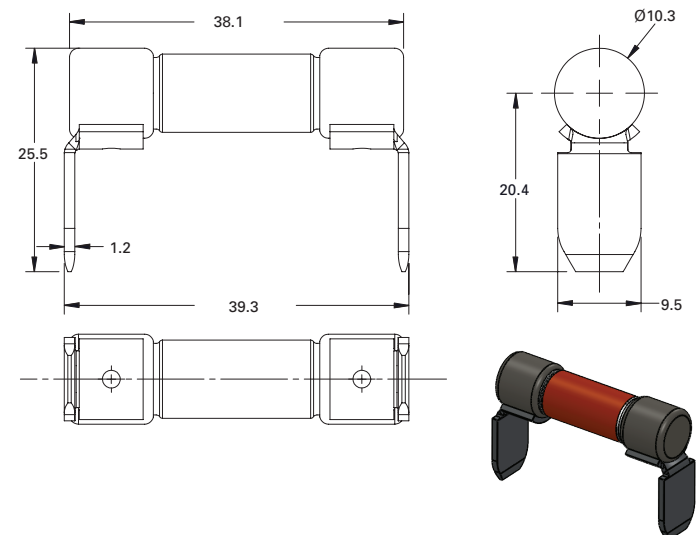

**10x38 mm PCB terminal**

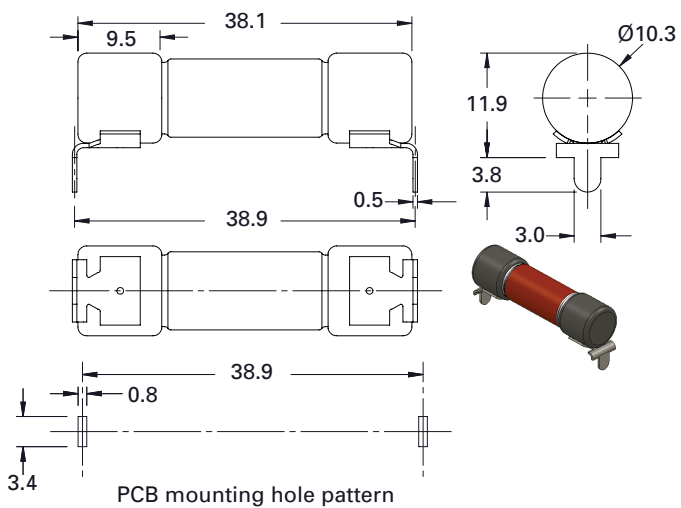

**DC minimum melt / maximum clearing time-current curves – multiple of rated current**

For 20 to 50 amp fuses supplied via DC rectifier @ 500 Vdc and time constant (L/R) 2 ms ± 0.5 ms



**Melting time correction factors**

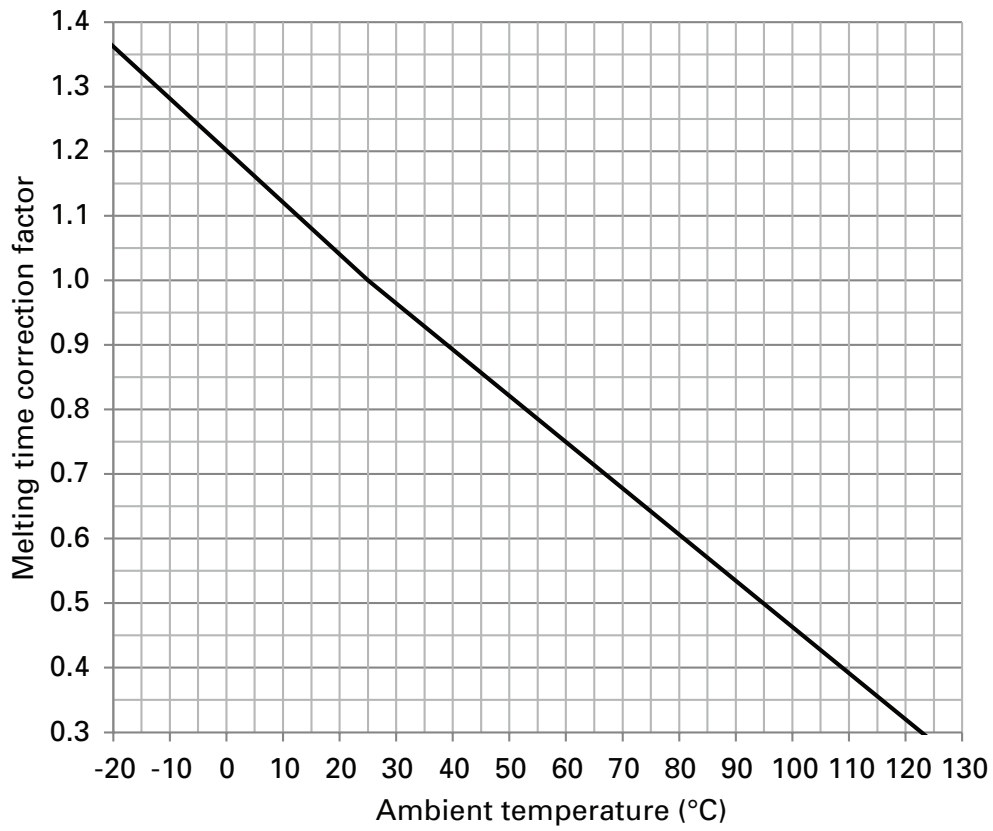

**Power loss correction factors**

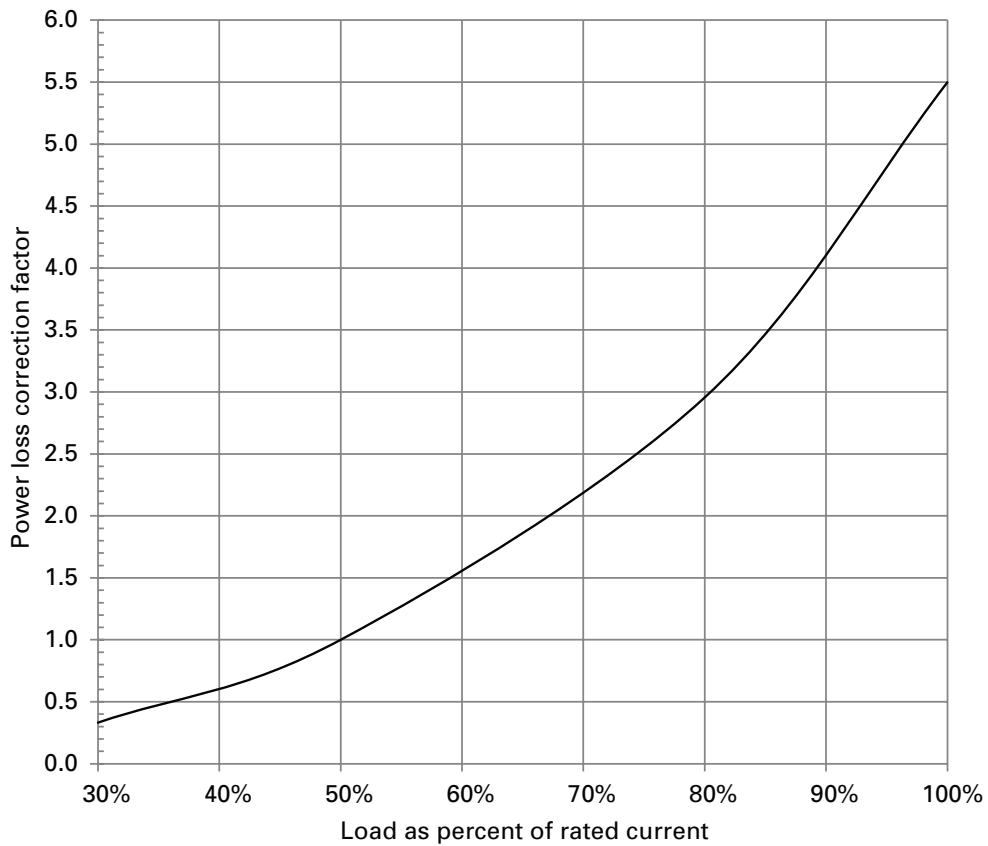

The only controlled copy of this data sheet is the electronic read-only version located on the Eaton network drive. All other copies of this document are by definition uncontrolled. This bulletin is intended to clearly present comprehensive product data and provide technical information that will help the end user with design applications. Eaton reserves the right, without notice, to change design or construction of any products and to discontinue or limit distribution of any products. Eaton also reserves the right to change or update, without notice, any technical information contained in this bulletin. Once a product has been selected, it should be tested by the user in all possible applications.

**Eaton**  
1000 Eaton Boulevard  
Cleveland, OH 44122  
Eaton.com

Bussmann Division  
114 Old State Road  
Ellisville, MO 63021  
United States  
Eaton.com/bussmannseries

© 2018 Eaton  
All Rights Reserved  
Printed in USA  
Publication No. 10864 — BU-MC18090  
December 2018

Eaton and Bussmann are valuable trademarks of Eaton in the US and other countries. You are not permitted to use the Eaton trademarks without prior written consent of Eaton.

For Eaton's Bussmann series product information, call **1-855-287-7626** or visit: **Eaton.com/bussmannseries**

Follow us on social media to get the latest product and support information.



Компания «Life Electronics» занимается поставками электронных компонентов импортного и отечественного производства от производителей и со складов крупных дистрибьюторов Европы, Америки и Азии.

С конца 2013 года компания активно расширяет линейку поставок компонентов по направлению коаксиальный кабель, кварцевые генераторы и конденсаторы (керамические, пленочные, электролитические), за счёт заключения дистрибьюторских договоров

Мы предлагаем:

- Конкурентоспособные цены и скидки постоянным клиентам.
- Специальные условия для постоянных клиентов.
- Подбор аналогов.
- Поставку компонентов в любых объемах, удовлетворяющих вашим потребностям.
- Приемлемые сроки поставки, возможна ускоренная поставка.
- Доставку товара в любую точку России и стран СНГ.
- Комплексную поставку.
- Работу по проектам и поставку образцов.
- Формирование склада под заказчика.
- Сертификаты соответствия на поставляемую продукцию (по желанию клиента).
- Тестирование поставляемой продукции.
- Поставку компонентов, требующих военную и космическую приемку.
- Входной контроль качества.
- Наличие сертификата ISO.

В составе нашей компании организован Конструкторский отдел, призванный помогать разработчикам, и инженерам.

Конструкторский отдел помогает осуществить:

- Регистрацию проекта у производителя компонентов.
- Техническую поддержку проекта.
- Защиту от снятия компонента с производства.
- Оценку стоимости проекта по компонентам.
- Изготовление тестовой платы монтаж и пусконаладочные работы.



Тел: +7 (812) 336 43 04 (многоканальный)

Email: [org@lifeelectronics.ru](mailto:org@lifeelectronics.ru)