

Product Overview

The QPC6054 is a Silicon on Insulator (SOI) Single-Pole 5-Throw (SP5T) switch designed for uses in cellular, 3G, LTE and other high-performance communication systems. It offers a high isolation, identical throw ports with excellent linearity and power handling capability. No DC blocking capacitors are necessary on the RF ports. The design is non-reflective as such the RF1, RF2, RF3, RF4 and RF5 ports are terminated with 50 Ω load(s) in the non-throw or All OFF state. The QPC6054 is 1.8V positive control logic compatible. It incorporates the control to disable the internal Negative Voltage Generator (NVG) and the required negative voltage supplied by an off-chip external source to the same pin.

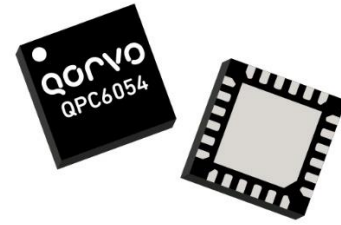

24-Pin, 4 x 4 mm QFN Package

Key Features

- 5 – 6000 MHz Operation
- Single Pole 5 Throw
- Non-Reflective RF1, RF2, RF3, RF4 & RF5 Ports, Terminated in ALL-OFF State
- No Blocking Capacitors Necessary Unless DC Voltage on RF line
- High Isolation: 60 dB at 2 GHz
- High Input IP3: +59 dBm
- +1.8 V Control Logic Compatible

Functional Block Diagram

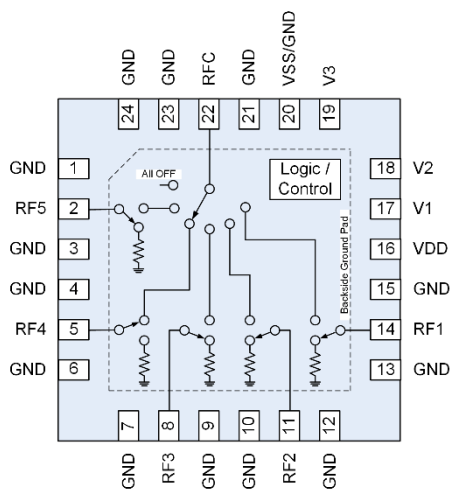

Top View

Applications

- Cellular, 3G, 4G, 5G Infrastructure
- WiBro, WiMax, LTE
- High Performance Communication Systems
- Test Equipment

Ordering Information

Part No.	Description
QPC6054TR13	2,500 pieces on a 13" reel (standard)
QPC6054 PCK410	5 MHz – 6GHz Evaluation Board with 5-piece samples

Absolute Maximum Ratings

Parameter	Rating	
Storage Temperature	-55 to +150 °C	
RF Input Power, non-internally terminated	+37.5 dBm	
RF Input Power, RFX terminated	+29 dBm	
Device Voltage	(VDD)	+6 V
	(VSS)	-6 V
Control Voltage (V1, V2, V3) Low / High	-0.2 V / +6 V	

Exceeding any one or a combination of the Absolute Maximum Rating conditions may cause permanent damage to the device. Extended application of Absolute Maximum Rating conditions to the device may reduce device reliability.

Recommended Operating Conditions

Parameter	Min	Typ	Max	Units
Device Voltage (VDD)	+2.7	+5.0	+5.5	V
Device Voltage (VSS), External Negative Voltage Supply	-5.5	-5.0	-2.7	V
Device Voltage (VSS), Internal Negative Voltage Generator		0		V
T _{CASE}	-40	+25	+105	°C
T _j for ≥10 ⁶ hours MTTF			+125	°C

Electrical specifications are measured at specified test conditions. Specifications are not guaranteed over all recommended operating conditions.

Electrical Specifications

Parameter	Conditions ⁽¹⁾	Min	Typ	Max	Units		
Operational Frequency Range		5		6000	MHz		
Insertion Loss ⁽²⁾ (RFC to RF1/RF2/RF3/RF4/RF5)	450 MHz		0.95	1.15	dB		
	900 MHz		1.00	1.20	dB		
	2100 MHz		1.10	1.30	dB		
	2600 MHz		1.17	1.40	dB		
	4000 MHz		1.40	1.70	dB		
Group Delay	ON Path		0.1	0.5	ns		
Isolation ⁽³⁾ (RFC to RF1/RF2/RF3/RF4)	450 MHz	61	70		dB		
	900 MHz	57	63		dB		
	2100 MHz	48	56		dB		
	2600 MHz	48	54		dB		
	4000 MHz	45	50		dB		
	5000 MHz	45	50		dB		
Isolation ⁽³⁾ (RF1/2/3/4/5 to RF1/2/3/4/5)	450 MHz	61	70		dB		
	900 MHz	56	66		dB		
	2100 MHz	50	59		dB		
	2600 MHz	48	56		dB		
	4000 MHz	43	50		dB		
	5000 MHz	41	48		dB		
Isolation (RF1 – RF4) ⁽³⁾	3500 MHz	50	56		dB		
	Isolation (RF2–RF1, RF2 ON) ⁽⁴⁾	5000 MHz	41	42.3		dB	
		Isolation (RF3–RF2, RF3 ON) ⁽⁴⁾	5000 MHz	41	42.8		dB
			Isolation (RF4–RF3, RF4 ON) ⁽⁴⁾	5000 MHz	43	44.8	
		Isolation (RF5–RF4, RF5 ON) ⁽⁴⁾	5000 MHz	40	41.7		dB
		Isolation (RF5–RF1, RF5 ON) ⁽⁴⁾	5000 MHz	43	45		dB

Notes:

1. Test conditions unless otherwise noted: VDD = +5V; V1, V2 and V3 = 0/+5V; T_A = +25 °C; Standard application circuit; 50 Ω system,
2. PCB trace loss deducted
3. Isolation based on an optimized evaluation board
4. Only these RF path-ports listed, and the other ports' isolation is better.

Electrical Specifications (continued)

Parameter	Conditions ⁽¹⁾	Min	Typ	Max	Units
Operational Frequency Range		5		6000	MHz
Return Loss (RF1/RF2/RF3/RF4/RF5 ON-State)	450 MHz		30		dB
	900 MHz		31		dB
	2100 MHz		31		dB
	2600 MHz		30		dB
	4000 MHz		20		dB
	5000 MHz		16		dB
	6000 MHz		12		dB
Return Loss (RF1/RF2/RF3/RF4/RF5 OFF-State)	450 MHz		37		dB
	900 MHz		30		dB
	2100 MHz		24		dB
	2600 MHz		23		dB
	4000 MHz		22		dB
	5000 MHz		19		dB
	6000 MHz		14		dB
Input IP2	1000 MHz		117		dBm
Input IP3	1.0 GHz, +17 dBm input power per-tone, 1 MHz tone spacing	55	59		dBm
Input 1 dB Compression Power		36			dBm
NVG Spur	Internal Negative Voltage Generator ON		-104		dBm
Spurious Signal Level	>100MHz			-120	dBm
Second Harmonic	Pin = +13 dBm, F ₀ = 1GHz		-105	-95	dBc
Third Harmonic	Pin = +13 dBm, F ₀ = 1GHz		-105	-95	dBc
Setting Time	50% V1/V2/V3 to optimum functionality		1	4	μs
Start-up Time	90% VDD to full functionality		5	25	μs
Switching Time	50% control to 10/90% RF		150	240	ns
Supply Current (I _{VDD})	VDD +5.0V		100		μA
Control Current, (I _{V1} , I _{V2} , I _{V3})	V1, V2, V3 each at +5.0V		2		μA
VSS Current (I _{VSS})	VSS -5.0V, Internal NVG disabled		100		μA
Low Control Voltage (V1, V2, V3)	+1.8 V Control Logic compatible	0		0.63	V
High Control Voltage (V1, V2, V3)		1.1		VDD	V

Notes:

1. Test conditions unless otherwise noted: VDD = +5V; V1, V2 and V3 = 0/+5V; T_A = +25 °C; Standard application circuit; 50 Ω system

Truth Table

Control Input			Mode of Signal Path
V1	V2	V3	
0	0	0	All OFF; RFC Reflective; RFX Terminated
1	0	0	RFC ⇔ RF1 Active ON
0	1	0	RFC ⇔ RF2 Active ON
1	1	0	RFC ⇔ RF3 Active ON
0	0	1	RFC ⇔ RF4 Active ON
1	0	1	RFC ⇔ RF5 Active ON
0	1	1	All OFF; RFC Reflective; RFX Terminated
1	1	1	

Maximum Operating Power at High Temperature, ≥50 MHz CW, 50 Ω System

Input Port	State	Power at each port		Thermal Resistance, θ_{jc}
		Tc +85°C	Tc +105°C	
RFC, RF1, RF2, RF3, RF4 or RF5	ON, Active Throw	35.5 dBm	32.3 dBm ⁽¹⁾	53 °C/W
RF1, RF2, RF3, RF4 or RF5	OFF, 1 port	28.1 dBm	25.1 dBm ⁽³⁾	61 °C/W
RF1, RF2, RF3, RF4, RF5	OFF, 2 ports adjacent	26.6 dBm	23.6 dBm ⁽²⁾⁽³⁾	86 °C/W
RF1, RF2, RF3, RF4 and RF5	OFF, All 5 ports	26.2 dBm	23.1dBm ⁽³⁾	96 °C/W

Notes:

1. For frequency <50 MHz, the maximum operating power at all temperatures should be at least 2 dB below P1dB refer to performance plot
2. On any two ports adjacent being driven simultaneously
3. Internally terminated OFF state

5 MHz to 6 GHz Evaluation Board – QPC6054PCK410

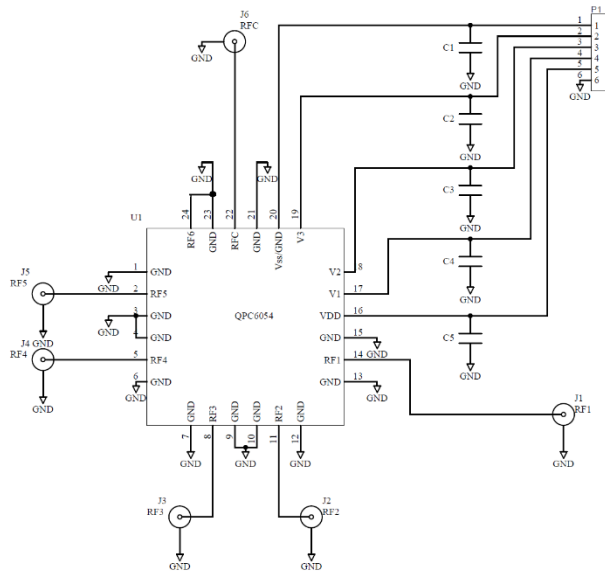
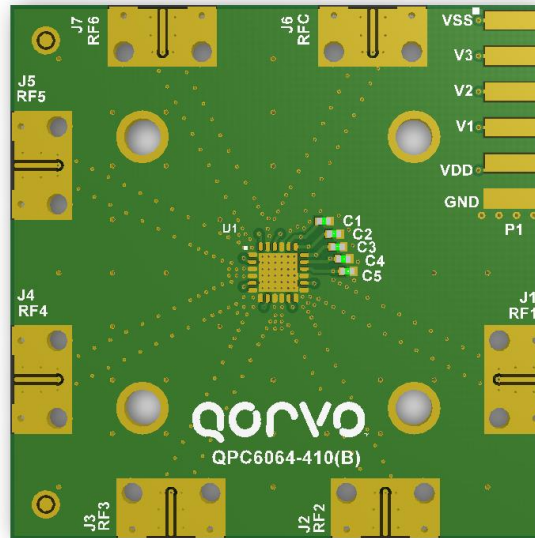

Bill of Material – QPC6054PCK410

Reference Des.	Value	Description	Manuf.	Part Number
-	-	PCB, QPC6064-410(B)	Qorvo	279707
U1	-	SOI, High Isolation SP5T RF switch	Qorvo	QPC6054
C1, C2, C3, C4, C5	100 pF	CAP, 100 pF, 5%, 50V, COG, 0402	Taiyo Yuden	RM UMK105 CG101JV-F
J1, J2, J3, J4, J5, J6	SMA	CONN, SMA, EL, FLT VIPER, MAT-21-1038	Amphenol	901-10425
P1	-	CONN, HDR, ST, PLRZD, 6-Pin, 0.100"	AMP	640454-6

Performance Plots – QPC6054PCK410

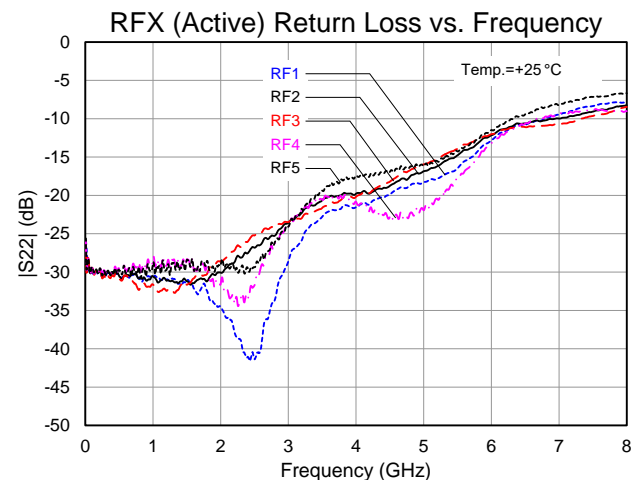
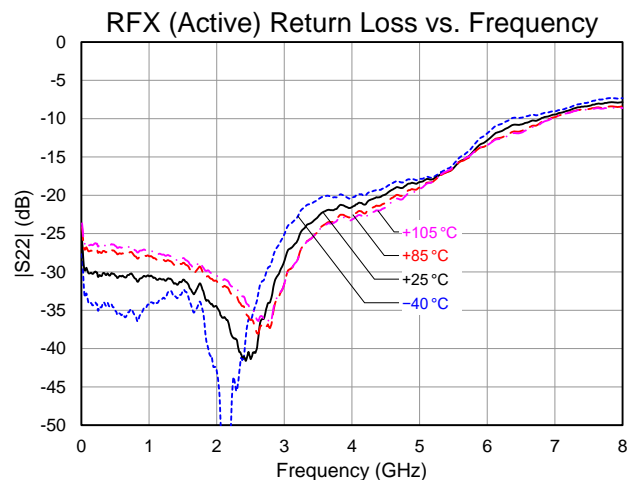
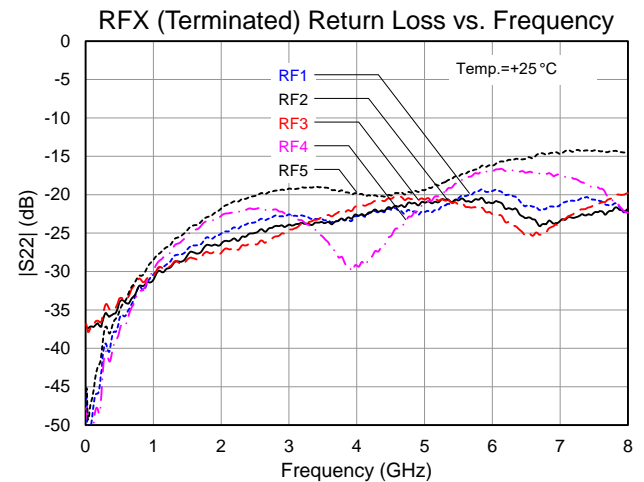
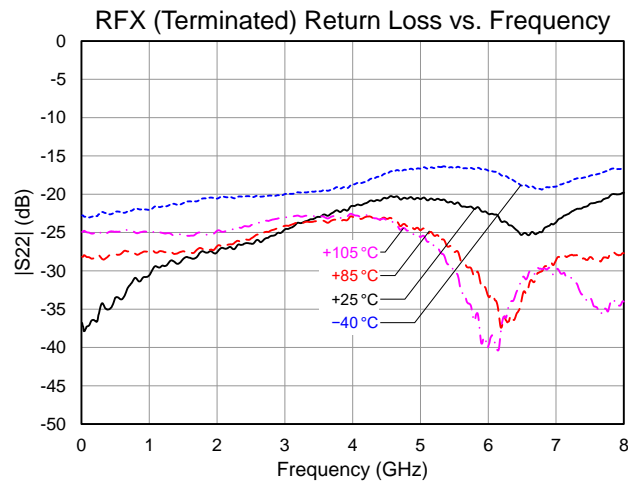
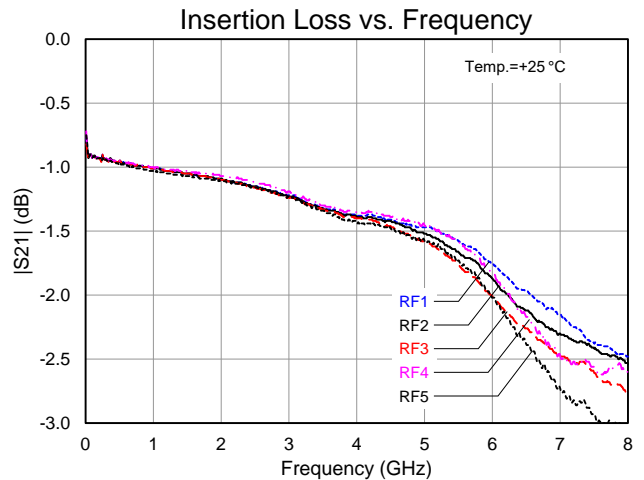
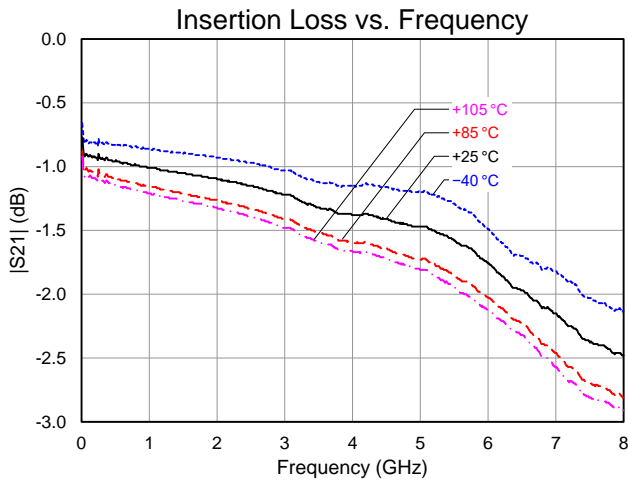

Performance Plots – QPC6054PCK410 (Continued)

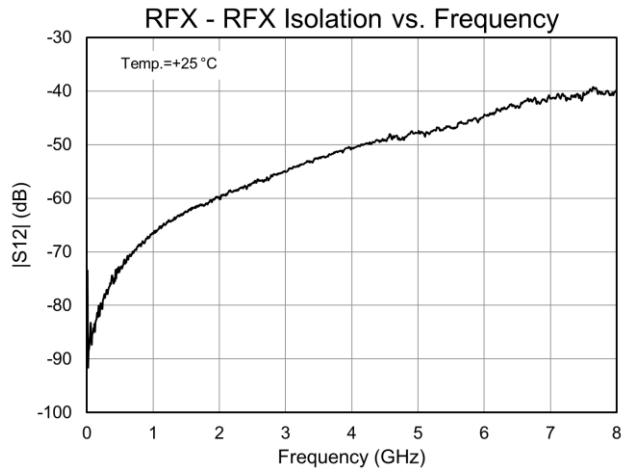
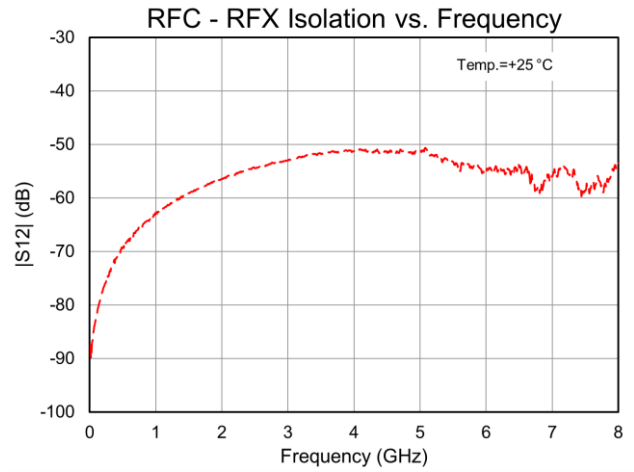
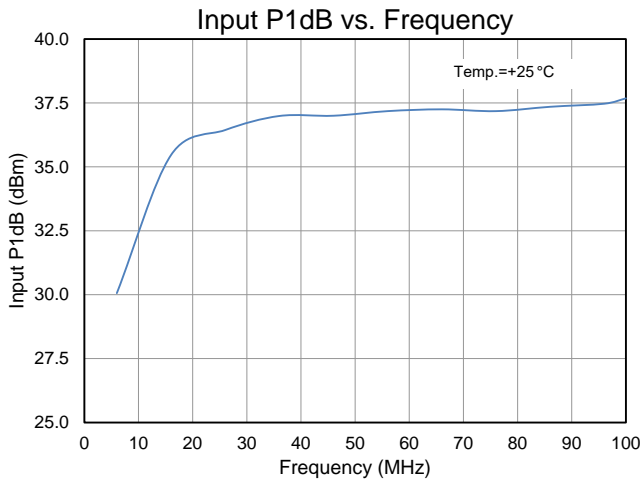
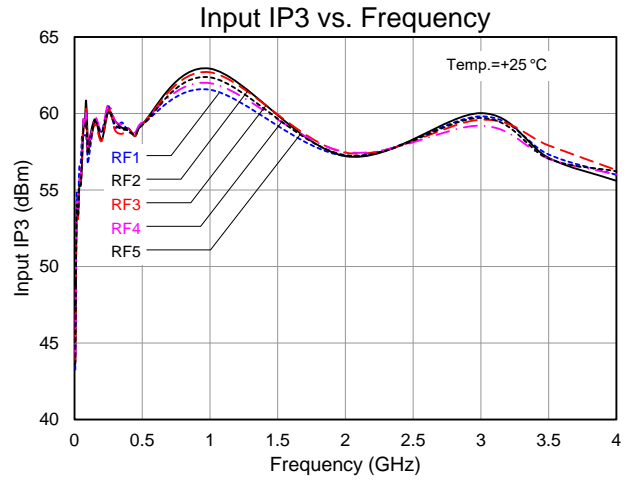
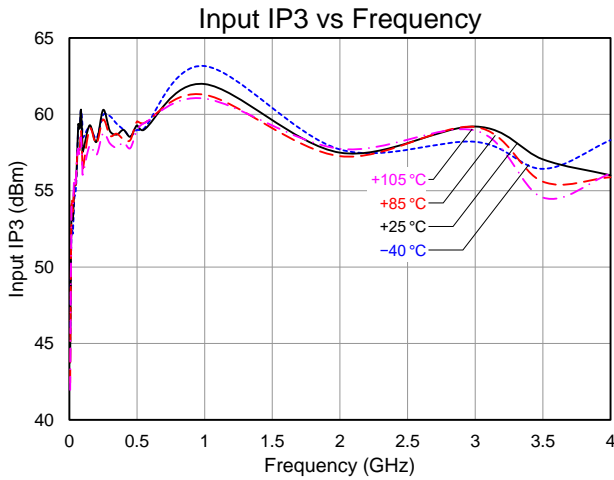

Pad Configuration and Description

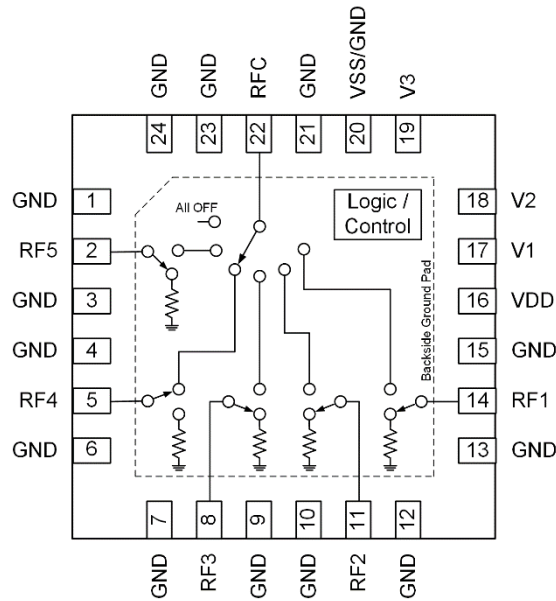

Top View

Pad No.	Label	Description
1, 3, 4, 6, 7, 9, 10, 12, 13, 15, 21, 23, 24	GND	DC and RF ground, connect to low inductive path to PCB ground
2	RF5	RF Port 5
5	RF4	RF Port 4
8	RF3	RF Port 3
11	RF2	RF Port 2
14	RF1	RF Port 1
16	VDD	DC Supply Voltage Input
17	V1	Control Input 1
18	V2	Control Input 2
19	V3	Control Input 3
20	VSS/GND	Negative DC Supply Voltage and Internal Negative Voltage Generator (NVG) control input. Provide low inductive ground connection on this pin to enable internal NVG or directly connect -2.7V to -5V external voltage supply to disable the internal NVG. Re-enable internal NVG, VDD cycling required
22	RFC	RF Common Port
Backside Paddle	GND	RF and DC ground. Must be soldered on PCB ground plane over a bed of via holes to minimize inductance and thermal resistance

Package Marking and Dimensions

Marking: Part Number – QPC
6054

Trace Code – Assigned by subcontractor

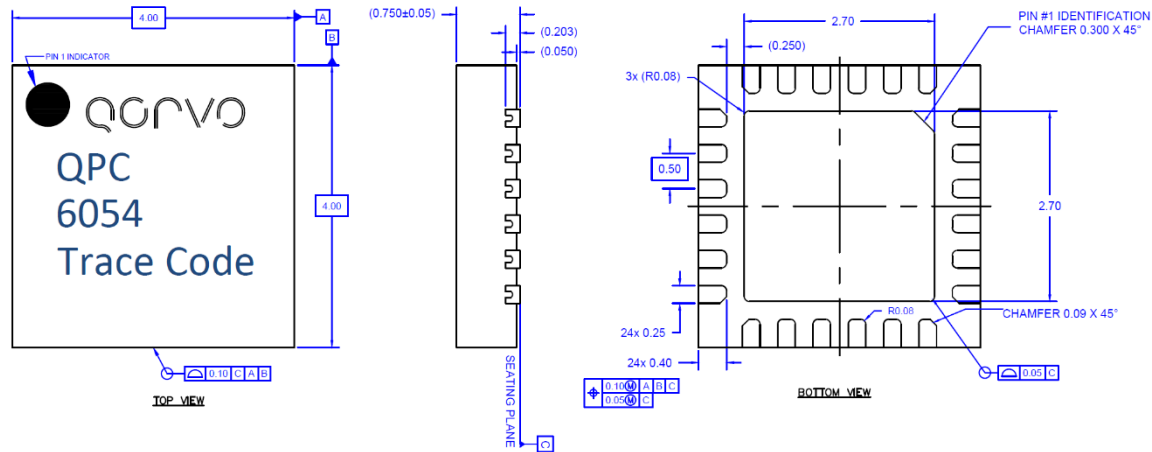

Notes:

1. All dimensions are in millimeters. Angles are in degrees.
2. The terminal #1 identifier and terminal numbering conform to JESD 95-1 SPP-012.
3. Contact plating: NiPdAu

PCB Mounting Pattern

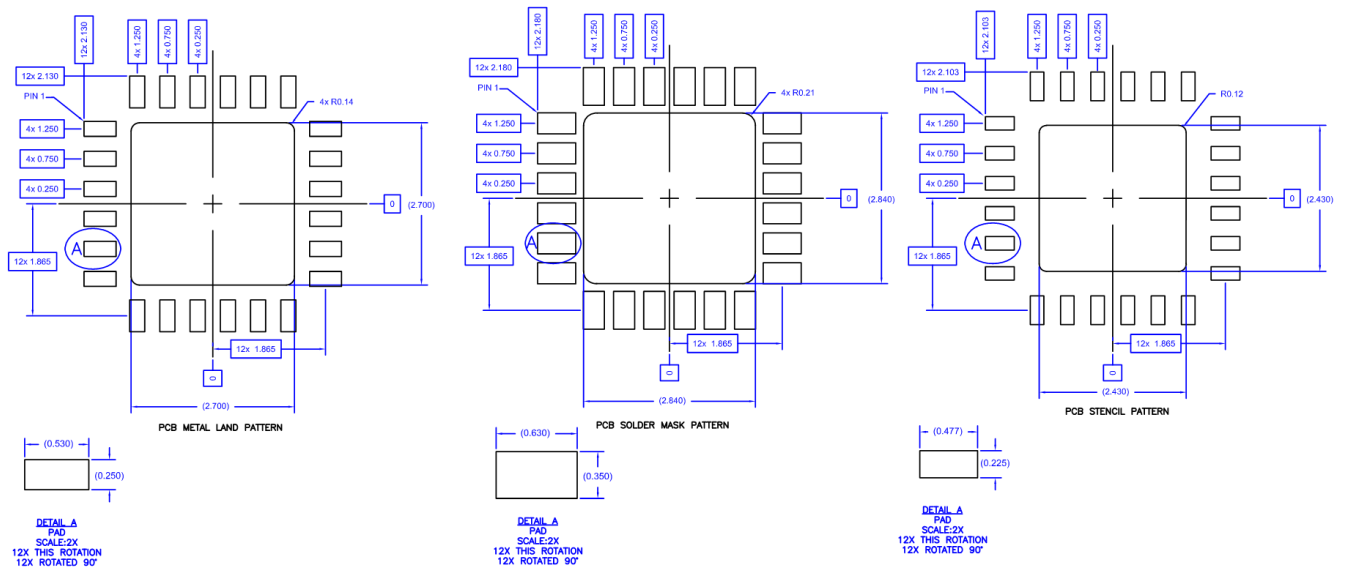

Notes:

1. All dimensions are in millimeters. Angles are in degrees.
2. Use 1 oz. copper minimum for top and bottom layer metal.
3. Via holes are required under the backside paddle of this device for proper RF/DC grounding and thermal dissipation. We recommend a 0.35mm (#80/.0135") diameter bit for drilling via holes and a final plated thru diameter of 0.25 mm (0.01").
4. Ensure good package backside paddle solder attach for reliable operation and best electrical performance.

Tape and Reel Information – Carrier and Cover Tape Dimensions

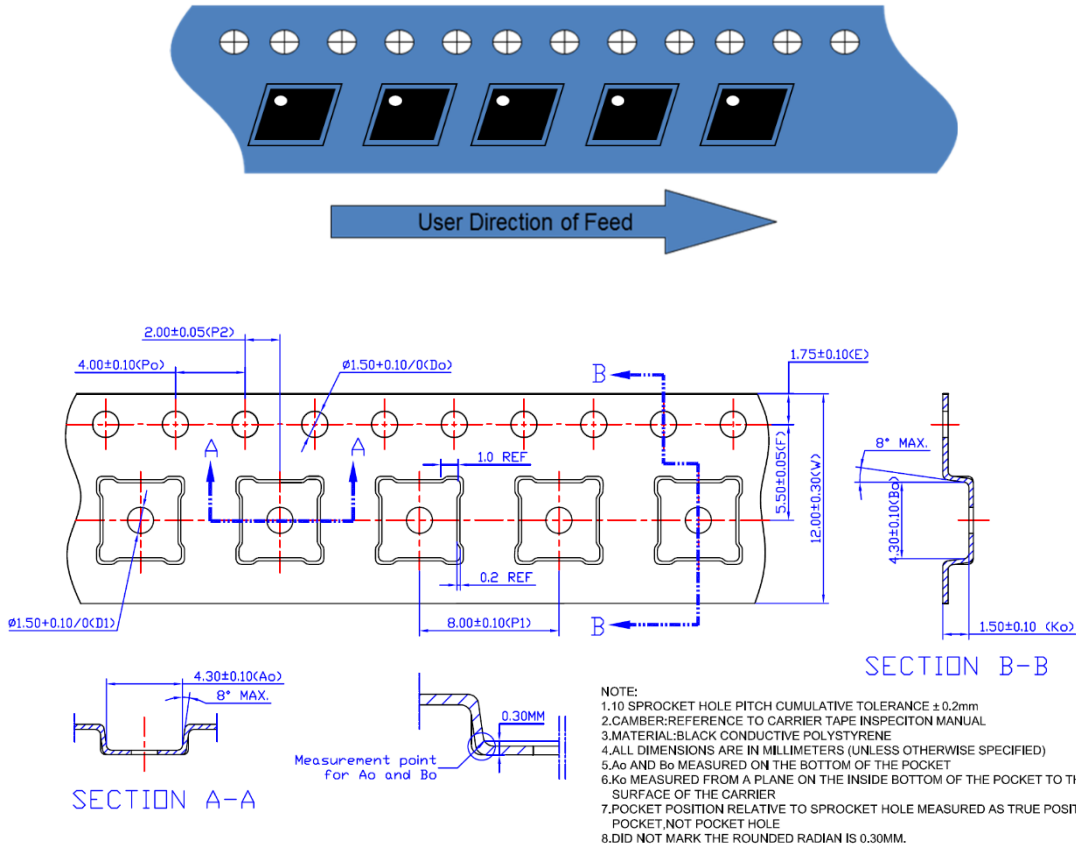

Feature	Measure	Symbol	Size (in)	Size (mm)
Cavity	Length	A0	0.169	4.30
	Width	B0	0.169	4.30
	Depth	K0	0.059	1.50
	Pitch	P1	0.314	8.00
Centerline Distance	Cavity to Perforation - Length Direction	P2	0.079	2.00
	Cavity to Perforation - Width Direction	F	0.217	5.50
Cover Tape	Width	C	0.362	9.20
Carrier Tape	Width	W	0.472	12.0

Tape and Reel Information – Reel Dimensions

Standard T/R size = 2,500 pieces on a 13" reel.

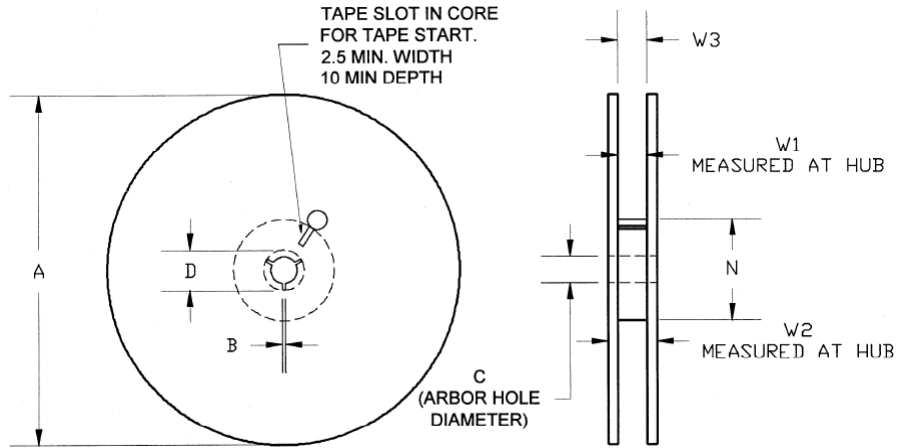

Feature	Measure	Symbol	Size (in)	Size (mm)
Flange	Diameter	A	12.992	330.0
	Thickness	W2	0.717	18.2
	Space Between Flange	W1	0.504	12.8
Hub	Outer Diameter	N	4.016	102.0
	Arbor Hole Diameter	C	0.512	13.0
	Key Slit Width	B	0.079	2.0
	Key Slit Diameter	D	0.787	20.0

Tape and Reel Information – Tape Length and Label Placement

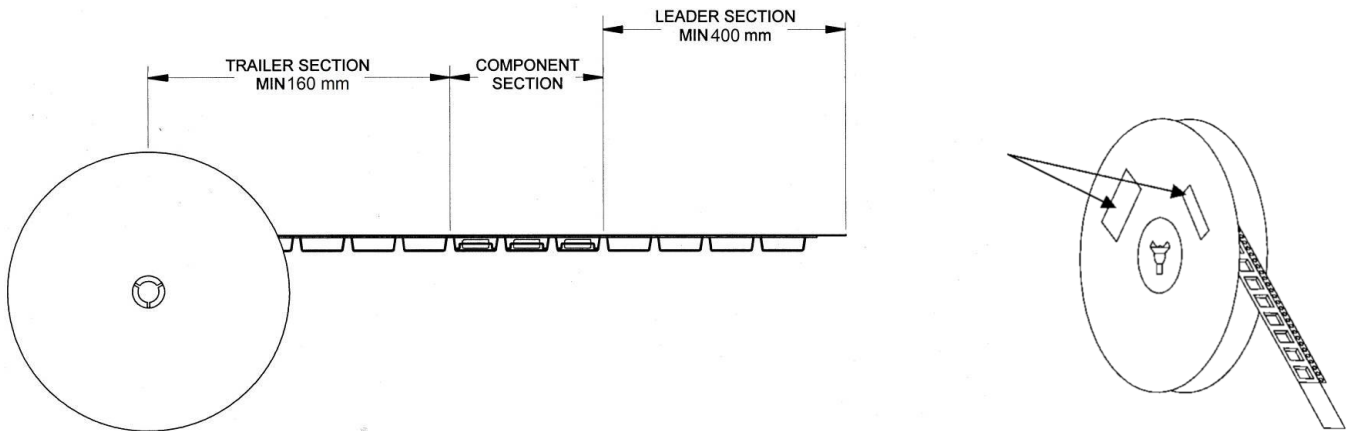

- Notes:
1. Empty part cavities at the trailing and leading ends are sealed with cover tape. See EIA 481-1-A.
 2. Labels are placed on the flange opposite the sprockets in the carrier tape.

Handling Precautions

Parameter	Rating	Standard
ESD – Human Body Model (HBM)	Class 2	ESDA / JEDEC JS-001-2012
ESD – Charged Device Model (CDM)	Class C3	JEDEC JESD22-C101F
MSL – Moisture Sensitivity Level	Level 2	IPC/JEDEC J-STD-020



Caution!
ESD-Sensitive Device

Solderability

Compatible with both lead-free (260°C max. reflow temp.) and tin/lead (245°C max. reflow temp.) soldering processes. Solder profiles available upon request.

Contact plating: NiPdAu

RoHS Compliance

This part is compliant with 2011/65/EU RoHS directive (Restrictions on the Use of Certain Hazardous Substances in Electrical and Electronic Equipment) as amended by Directive 2015/863/EU.

This product also has the following attributes:

- Lead Free
- Halogen Free (Chlorine, Bromine)
- Antimony Free
- TBBP-A (C₁₅H₁₂Br₄O₂) Free
- SVHC Free



Contact Information

For the latest specifications, additional product information, worldwide sales and distribution locations:

Web: www.qorvo.com

Tel: 1-844-890-8163

Email: customer.support@qorvo.com

Important Notice

The information contained herein is believed to be reliable; however, Qorvo makes no warranties regarding the information contained herein and assumes no responsibility or liability whatsoever for the use of the information contained herein. All information contained herein is subject to change without notice. Customers should obtain and verify the latest relevant information before placing orders for Qorvo products. The information contained herein or any use of such information does not grant, explicitly or implicitly, to any party any patent rights, licenses, or any other intellectual property rights, whether with regard to such information itself or anything described by such information. **THIS INFORMATION DOES NOT CONSTITUTE A WARRANTY WITH RESPECT TO THE PRODUCTS DESCRIBED HEREIN, AND QORVO HEREBY DISCLAIMS ANY AND ALL WARRANTIES WITH RESPECT TO SUCH PRODUCTS WHETHER EXPRESS OR IMPLIED BY LAW, COURSE OF DEALING, COURSE OF PERFORMANCE, USAGE OF TRADE OR OTHERWISE, INCLUDING THE IMPLIED WARRANTIES OF MERCHANTABILITY AND FITNESS FOR A PARTICULAR PURPOSE.**

Without limiting the generality of the foregoing, Qorvo products are not warranted or authorized for use as critical components in medical, life-saving, or life-sustaining applications, or other applications where a failure would reasonably be expected to cause severe personal injury or death.

Copyright 2020 © Qorvo, Inc. | Qorvo is a registered trademark of Qorvo, Inc.

Компания «Life Electronics» занимается поставками электронных компонентов импортного и отечественного производства от производителей и со складов крупных дистрибьюторов Европы, Америки и Азии.

С конца 2013 года компания активно расширяет линейку поставок компонентов по направлению коаксиальный кабель, кварцевые генераторы и конденсаторы (керамические, пленочные, электролитические), за счёт заключения дистрибьюторских договоров

Мы предлагаем:

- Конкуренеспособные цены и скидки постоянным клиентам.
- Специальные условия для постоянных клиентов.
- Подбор аналогов.
- Поставку компонентов в любых объемах, удовлетворяющих вашим потребностям.
- Приемлемые сроки поставки, возможна ускоренная поставка.
- Доставку товара в любую точку России и стран СНГ.
- Комплексную поставку.
- Работу по проектам и поставку образцов.
- Формирование склада под заказчика.
- Сертификаты соответствия на поставляемую продукцию (по желанию клиента).
- Тестирование поставляемой продукции.
- Поставку компонентов, требующих военную и космическую приемку.
- Входной контроль качества.
- Наличие сертификата ISO.

В составе нашей компании организован Конструкторский отдел, призванный помогать разработчикам, и инженерам.

Конструкторский отдел помогает осуществить:

- Регистрацию проекта у производителя компонентов.
- Техническую поддержку проекта.
- Защиту от снятия компонента с производства.
- Оценку стоимости проекта по компонентам.
- Изготовление тестовой платы монтаж и пусконаладочные работы.



Тел: +7 (812) 336 43 04 (многоканальный)

Email: org@lifeelectronics.ru