



# PCA8543

## 4 x 60 automotive LCD segment driver with integrated charge pump

Rev. 2 — 7 April 2015

Product data sheet

## 1. General description

The PCA8543 is a peripheral device which interfaces to almost any Liquid Crystal Display (LCD)<sup>1</sup> with low multiplex rates. It generates the drive signals for any static or multiplexed LCD containing up to four backplanes, 60 segments, and up to 240 elements. The PCA8543 is compatible with most microcontrollers and communicates via the two-line bidirectional I<sup>2</sup>C-bus. Communication overheads are minimized using a display RAM with auto-incremented addressing and display memory switching. The PCA8543 features an internal charge pump with internal capacitors for on-chip generation of the LCD driving voltages.

For a selection of NXP LCD segment drivers, see [Table 40 on page 59](#).

## 2. Features and benefits

- AEC Q100 grade 2 compliant for automotive applications
- Low power consumption
- Extended operating temperature range from -40 °C to +105 °C
- 60 segments and 4 backplanes allowing to drive:
  - ◆ up to 30 7-segment alphanumeric characters
  - ◆ up to 15 14-segment alphanumeric characters
  - ◆ any graphics of up to 240 elements
- Selectable backplane drive configuration: static, 2, or 4 backplane multiplexing
- Programmable internal charge pump for on-chip LCD voltage generation up to  $3 \times V_{DD2}$
- 400 kHz I<sup>2</sup>C-bus interface
- Selectable linear temperature compensation of  $V_{LCD}$
- Selectable display bias configuration
- Wide range for digital and analog power supply: from 2.5 V to 5.5 V
- Wide LCD supply range: from 2.5 V for low threshold LCDs and up to 9.0 V for high threshold (automobile) twisted nematic LCDs
- On-chip RAM for display data storage arranged in two banks
- Display memory bank switching
- Programmable frame frequency in steps of 10 Hz in the range of 60 Hz to 300 Hz; factory calibrated with a tolerance of  $\pm 15\%$  covering the whole temperature and voltage range
- Selectable inversion scheme for LCD driving waveforms: frame or line inversion

1. The definition of the abbreviations and acronyms used in this data sheet can be found in [Section 19 on page 61](#).



- Integrated temperature sensor with temperature readout
- On chip calibration of internal oscillator frequency and  $V_{LCD}$

### 3. Applications

- Instrument cluster
- Car radio
- Climate control units

### 4. Ordering information

Table 1. Ordering information

Type number	Package		
	Name	Description	Version
PCA8543AHL	LQFP80	plastic low profile quad flat package; 80 leads; body 12 × 12 × 1.4 mm	SOT315-1

#### 4.1 Ordering options

Table 2. Ordering options

Product type number	Sales item (12NC)	Orderable part number	IC revision	Delivery form
PCA8543AHL/A	935303762518	PCA8543AHL/AY	1	tape and reel, 13 inch, dry pack

### 5. Marking

Table 3. Marking codes

Type number	Marking code
PCA8543AHL	PCA8543AHL

## 6. Block diagram

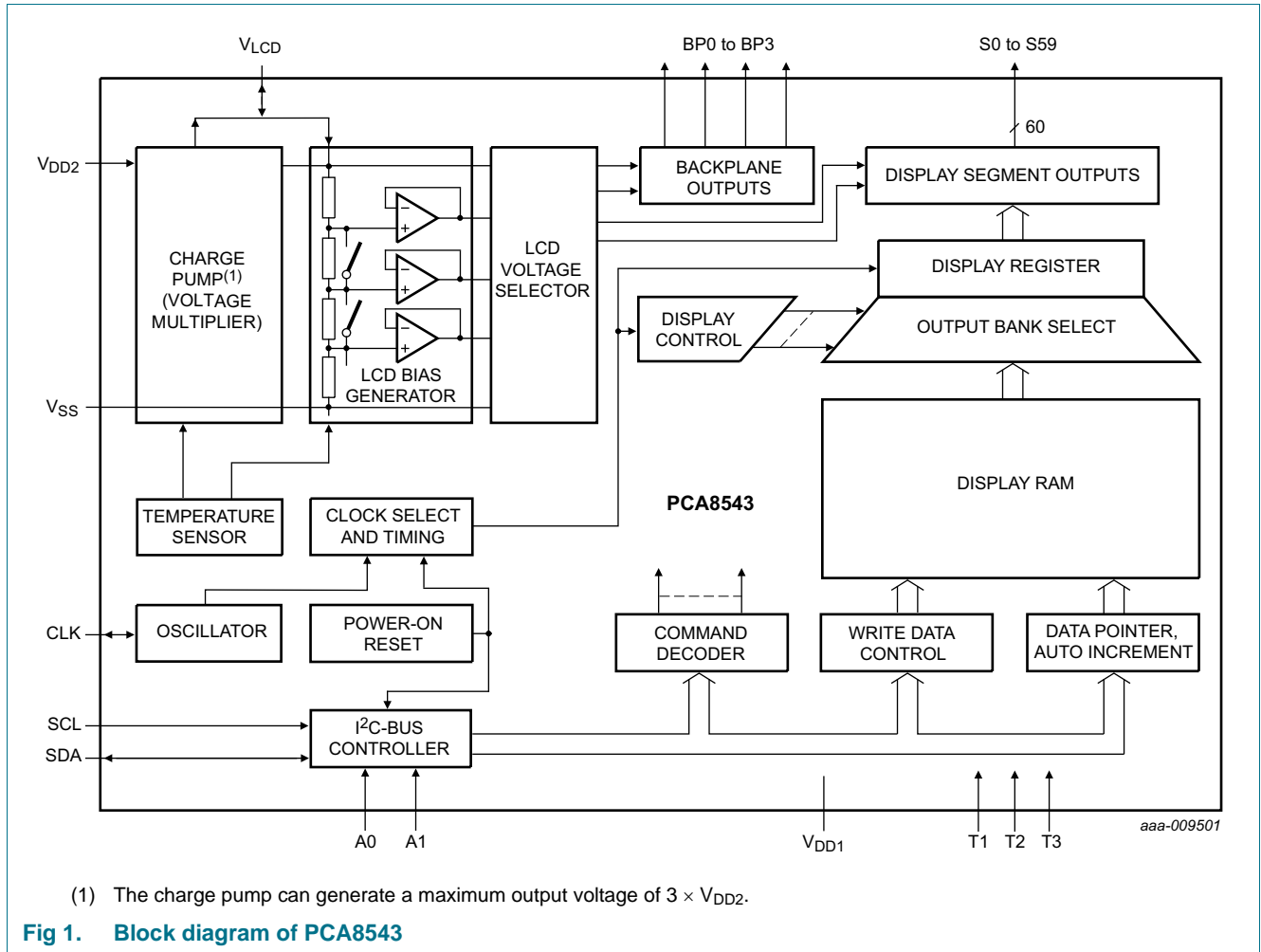

## 7. Pinning information

### 7.1 Pinning

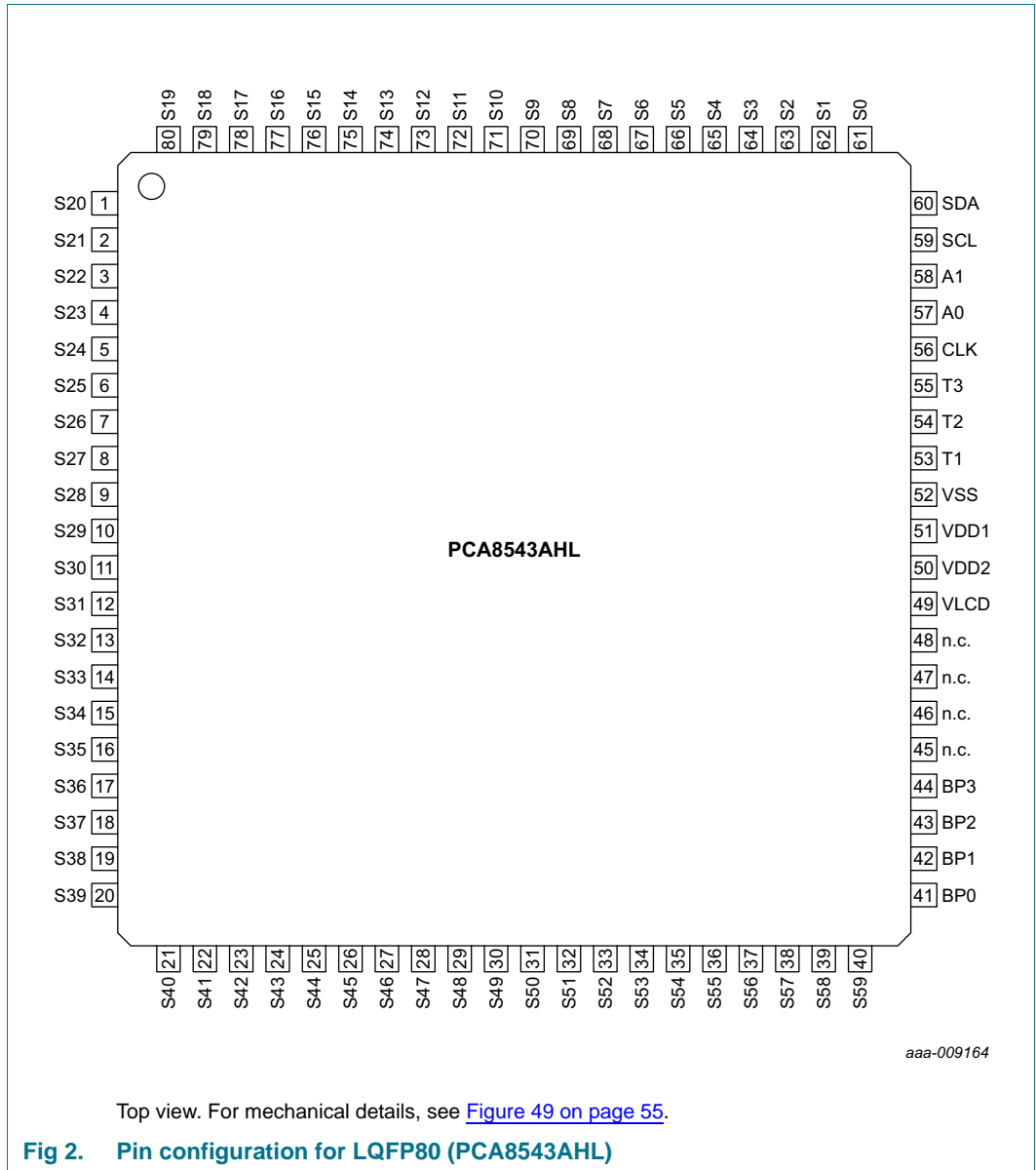

## 7.2 Pin description

**Table 4. Pin description**

*Input or input/output pins must always be at a defined level ( $V_{SS}$  or  $V_{DD}$ ) unless otherwise specified.*

Symbol	Pin	Type	Description
S0 to S59	61 to 80 and 1 to 40	output	LCD segment
BP0 to BP3	41 to 44	output	LCD backplane
n.c.	45 to 48	-	not connected; do not connect and do not use as feed through
$V_{LCD}$	49	supply/output <sup>[1]</sup>	LCD supply voltage
$V_{DD2}$	50	supply	supply voltage 2 (charge pump)
$V_{DD1}$	51	supply	supply voltage 1 (analog and digital)
$V_{SS}$	52	supply	ground supply voltage
T1 to T3	53 to 55	input	test pins; must be tied to $V_{SS}$ in applications
CLK	56	input/output	internal oscillator output, external oscillator input
A0, A1	57, 58	input	I <sup>2</sup> C-bus slave address selection bit
SCL	59	input	I <sup>2</sup> C-bus serial clock
SDA	60	input/output	I <sup>2</sup> C-bus serial data

- [1] When the internal  $V_{LCD}$  generation is used, this pin drives the  $V_{LCD}$  voltage. In this case pin  $V_{LCD}$  is an output. When the external supply is requested, then pin  $V_{LCD}$  is an input and  $V_{LCD}$  can be supplied to it. In this case, the internal charge pump must be disabled (see [Table 9 on page 8](#)).

## 8. Functional description

The PCA8543 is a versatile peripheral device designed to interface any microcontroller to a wide variety of LCDs. It can directly drive any static or multiplexed LCD containing up to 240 elements.

### 8.1 Commands of PCA8543

The PCA8543 is controlled by the commands defined in [Table 5](#). Any other combinations of operation code bits that are not mentioned in this document may lead to undesired operation modes of the PCA8543.

**Table 5. Commands of PCA8543**

Command name	Bits								Reference	
	7	6	5	4	3	2	1	0		
initialize									<a href="#">Section 8.1.1</a>	
initialize-MSB	0	0	1	1	1	0	1	0		
initialize-LSB	0	0	0	0	0	1	0	0		
OTP-refresh	1	1	0	1	0	0	0	0		<a href="#">Section 8.1.2</a>
oscillator-ctrl	1	1	0	0	1	1	COE	OSC	<a href="#">Section 8.1.3</a>	
charge-pump-ctrl	1	1	0	0	0	0	CPE	CPC	<a href="#">Section 8.1.4</a>	
temp-msr-ctrl	1	1	0	0	1	0	TCE	TME	<a href="#">Section 8.1.5</a>	
temp-comp-SLA	0	0	0	1	1	SLA[2:0]			<a href="#">Table 30</a>	
temp-comp-SLB	0	0	1	0	0	SLB[2:0]				
temp-comp-SLC	0	0	1	0	1	SLC[2:0]				
temp-comp-SLD	0	0	1	1	0	SLD[2:0]				
set-VPR-MSB	0	1	0	0	VPR[7:4]				<a href="#">Section 8.1.6</a>	
set-VPR-LSB	0	1	0	1	VPR[3:0]					
display-enable	0	0	1	1	1	0	0	E	<a href="#">Section 8.1.7</a>	
set-MUX-mode	0	0	0	0	0	M[2:0]			<a href="#">Section 8.1.8</a>	
set-bias-mode	1	1	0	0	0	1	B[1:0]			
load-data-pointer	1	0	P[5:0]						<a href="#">Section 8.1.10</a>	
frame-frequency	0	1	1	F[4:0]						<a href="#">Section 8.1.11</a>
input-bank-select	0	0	0	0	1	IB	0	0	<a href="#">Section 8.1.12.1</a>	
output-bank-select	0	0	0	1	0	OB	0	0		
write-RAM-data	B[7:0]								<a href="#">Section 8.1.13</a>	
temp-read	TD[7:0]								<a href="#">Section 8.1.14</a> , <a href="#">Section 8.4.7</a>	
invmode_CPF_ctrl	1	1	0	1	0	1	LF	CPF	<a href="#">Section 8.1.15</a>	
temp-filter	1	1	0	1	0	0	1	TFE	<a href="#">Section 8.1.16</a>	

#### 8.1.1 Command: initialize

This command generates a chip-wide reset. It consists of two bytes which have both to be sent to the device. It must be sent to the PCA8543 after power-on. After this command is sent, it is possible to send additional commands without the need to re-initialize the interface.

For further information, see [Section 8.3 on page 15](#).

**Table 6. Initialize - initialize command bit description**

Bit	Symbol	Value	Description
<b>Initialize-MSB</b>			
7 to 0	-	00111010	fixed value
<b>Initialize-LSB</b>			
7 to 0	-	00000100	fixed value

### 8.1.2 Command: OTP-refresh

In order to achieve the specified accuracy of  $V_{LCD}$ , the frame frequency, and the temperature measurement, each IC is calibrated during production and testing of the device. This calibration is performed on EPROM cells called One Time Programmable (OTP) cells. These cells are read by the device at power-on and every time when the initialize command or the OTP-refresh command is sent. This command will take approximately 10 ms to finish.

**Table 7. OTP-refresh - OTP-refresh command bit description**

Bit	Symbol	Value	Description
7 to 0	-	11010000	fixed value

### 8.1.3 Command: oscillator-ctrl

The oscillator-ctrl command switches between internal and external oscillator and enables or disables pin CLK.

**Table 8. Oscillator-ctrl - oscillator control command bit description**

For further information, see [Section 8.5 on page 35](#).

Bit	Symbol	Value	Description
7 to 2	-	110011	fixed value
1	COE		control pin CLK
		0 <sup>[1]</sup>	clock signal not available on pin CLK; pin CLK is in 3-state and may be left floating
		1	clock signal available on pin CLK
0	OSC		oscillator source
		0 <sup>[1]</sup>	internal oscillator running
		1	external oscillator used; pin CLK becomes an input

[1] Default value.

### 8.1.4 Command: charge-pump-ctrl

The charge-pump-ctrl command enables or disables the internal  $V_{LCD}$  generation and controls the charge pump voltage multiplier setting.

**Table 9. Charge-pump-ctrl - charge pump control command bit description**

Bit	Symbol	Value	Description
7 to 2	-	110000	fixed value
1	CPE		charge pump switch
		0 <sup>[1]</sup>	charge pump disabled; no internal $V_{LCD}$ generation; external supply of $V_{LCD}$
		1	charge pump enabled
0	CPC		charge pump voltage multiplier setting
		0 <sup>[1]</sup>	$V_{LCD} = 2 \times V_{DD2}$
		1	$V_{LCD} = 3 \times V_{DD2}$

[1] Default value.

### 8.1.5 Command: temp-msr-ctrl

The temp-msr-ctrl command enables or disables the temperature measurement block and the temperature compensation of  $V_{LCD}$ .

**Table 10. Temp-msr-ctrl - temperature measurement control command bit description**

For further information, see [Section 8.4.8 on page 33](#).

Bit	Symbol	Value	Description
7 to 2	-	110010	fixed value
1	TCE		temperature compensation switch
		0	no temperature compensation of $V_{LCD}$ possible
		1 <sup>[1]</sup>	temperature compensation of $V_{LCD}$ possible
0	TME		temperature measurement switch
		0	temperature measurement disabled; no temperature readout possible
		1 <sup>[1]</sup>	temperature measurement enabled; temperature readout possible

[1] Default value.

### 8.1.6 Command: set-VPR-MSB and set-VPR-LSB

With these two instructions, it is possible to set the target  $V_{LCD}$  voltage for the internal charge pump, see [Section 8.4.3 on page 28](#).

**Table 11. Set-VPR-MSB - set VPR MSB command bit description**

Bit	Symbol	Value	Description
7 to 4	-	0100	fixed value
3 to 0	VPR[7:4]	0000 <sup>[1]</sup> to 1111	the four most significant bits of VPR[7:0]

[1] Default value.



**Table 12. Set-VPR-LSB - set VPR LSB command bit description**

Bit	Symbol	Value	Description
7 to 4	-	0101	fixed value
3 to 0	VPR[3:0]	0000 <sup>[1]</sup> to 1111	the four least significant bits of VPR[7:0]

[1] Default value.

### 8.1.7 Command: display-enable

**Table 13. Display-enable - display enable command bit description**

Bit	Symbol	Value	Description
7 to 1	-	0011100	fixed value
0	E	0 <sup>[1]</sup>	display disabled; backplane and segment outputs are internally connected to V <sub>SS</sub>
		1	display enabled

[1] Default value.

### 8.1.8 Command: set-MUX-mode

**Table 14. Set-MUX-mode - set multiplex drive mode command bit description**

Bit	Symbol	Value	Description
7 to 3	-	00000	fixed value
2 to 0	M[2:0]	001	static drive mode: 1 backplane
		010	1:2 multiplex drive mode: 2 backplanes
		100 <sup>[1]</sup>	1:4 multiplex drive mode: 4 backplanes

[1] Default value.

### 8.1.9 Command: set-bias-mode

**Table 15. Set-bias-mode - set bias mode command bit description**

Bit	Symbol	Value	Description
7 to 2	-	110001	fixed value
1 to 0	B[1:0]	00 <sup>[1]</sup> , 01	1/4 bias
		11	1/3 bias
		10	1/2 bias

[1] Default value.

### 8.1.10 Command: load-data-pointer

The load-data-pointer command defines one of the 60 display RAM addresses where the following display data will be sent to. For further information, see [Section 8.9.1 on page 38](#).

**Table 16. Load-data-pointer - load data pointer command bit description**

Bit	Symbol	Value	Description
7 to 6	-	10	fixed value
5 to 0	P[5:0]	000000 to 111111	6-bit binary value of 0 to 59

### 8.1.11 Command: frame-frequency

With the frame-frequency command, the frame frequency and the output clock frequency can be configured.

**Table 17. Frame frequency - frame frequency and output clock frequency command bit description**

Bit	Symbol	Value	Description
7 to 5	-	011	fixed value
4 to 0	F[4:0]	see <a href="#">Table 18</a>	nominal frame frequency (Hz)

**Table 18. Frame frequency values**

F[4:0]	Nominal frame frequency, $f_{fr}$ (Hz) <sup>[1]</sup>	Resultant oscillator frequency, $f_{osc}$ (Hz)	Duty cycle (%) <sup>[2]</sup>
00000	60	2880	20 : 80
00001	70	3360	7 : 93
00010	80	3840	47 : 53
00011	91	4368	40 : 60
00100	100	4800	33 : 67
00101	109	5232	27 : 73
00110	120	5760	20 : 80
00111	129.7	6226	13 : 87
01000	141.2	6778	5 : 95
01001	150	7200	50 : 50
01010	160	7680	47 : 53
01011	171.4	8227	43 : 57
01100	177.8	8534	41 : 59
01101	192	9216	36 : 64
01110 <sup>[3]</sup>	200	9600	33 : 67
01111	208.7	10018	30 : 70
10000	218.2	10474	27 : 73
10001	228.6	10973	23 : 77
10010	240	11520	20 : 80
10011	252.6	12125	16 : 84
10100, 10101	266.7	12802	10 : 90
10110, 10111	282.4	13555	5 : 95
11000 to 11111	300	14400	50 : 50

[1] Nominal frame frequency calculated for the default clock frequency of 9600 Hz.

[2] Duty cycle definition: % HIGH-level time : % LOW-level time.

[3] Default value.

### 8.1.12 Bank select commands

It is possible to write data to one area of the RAM while displaying it from another. These areas are named as RAM banks. Input and output banks can be set independently from one another with the input-bank-select and the output-bank-select command. For further information, see [Section 8.9.2 on page 42](#).

### 8.1.12.1 Command: input-bank-select

**Table 19. Input-bank-select - input bank select command bit description**

Bit	Symbol	Value	Description
7 to 3	-	00001	fixed value
2	IB		selects RAM bank to write to
		0 <sup>[1]</sup>	bank 0
		1	bank 1
1 to 0	-	00	fixed value

[1] Default value.

### 8.1.12.2 Command: output-bank-select

**Table 20. Output-bank-select - output bank select command bit description**

Bit	Symbol	Value	Description
7 to 3	-	00010	fixed value
2	OB		selects RAM bank to read from to the LCD
		0 <sup>[1]</sup>	bank 0
		1	bank 1
1 to 0	-	00	fixed value

[1] Default value.

### 8.1.13 Command: write-RAM-data

The write-RAM-data command writes data byte-wise to the RAM. After Power-On Reset (POR) the RAM content is random and should be brought to a defined status by clearing it (setting it logic 0).

**Table 21. Write-RAM-data - write RAM data command bit description<sup>[1]</sup>**

Bit	Symbol	Value	Description
7 to 0	B[7:0]	00000000 to 11111111	writing data byte-wise to RAM

[1] For this command bit RS of the control byte has to be set logic 1 (see [Table 34 on page 46](#)).

More information about the display RAM can be found in [Section 8.9 on page 37](#).

### 8.1.14 Command: temp-read

The temp-read command allows reading out the temperature values measured by the internal temperature sensor.

**Table 22. Temp-read - temperature readout command bit description<sup>[1]</sup>**

For further information, see [Table 10 on page 8](#) and [Section 8.4.7 on page 32](#).

Bit	Symbol	Value	Description
7 to 0	TD[7:0]	00000000 to 11111111	readout representing the digital temperature

[1] For this command bit  $\overline{R/W}$  of the I<sup>2</sup>C-bus slave address byte has to be set logic 1 (see [Table 33 on page 45](#)).

### 8.1.15 Command: invmode\_CPF\_ctrl

The invmode\_CPF\_ctrl command allows changing the drive scheme inversion mode and the charge pump frequency.

The waveforms used to drive LCD displays inherently produce a DC voltage across the display cell. The PCA8543 compensates for the DC voltage by inverting the waveforms on alternate frames or alternate lines. The choice of compensation method is determined with the LF bit.

**Table 23. Invmode\_CPF\_ctrl - inversion mode and charge pump frequency prescaler command bit description**

Bit	Symbol	Value	Description
7 to 2	-	110101	fixed value
1	LF		set inversion mode
		0 <sup>[1]</sup>	line inversion mode (driving scheme A)
		1	frame inversion mode (driving scheme B)
0	CPF		set charge pump oscillator frequency
		0 <sup>[1]</sup>	$f_{osc(cp)} \sim 1$ MHz
		1	$f_{osc(cp)} \sim 500$ kHz

[1] Default value.

In frame inversion mode, the DC value is compensated across two frames and not within one frame. Changing the inversion mode to frame inversion reduces the power consumption, therefore it is useful when power consumption is a key point in the application.

Frame inversion may not be suitable for all applications. The RMS voltage across a segment is better defined, however since the switching frequency is reduced there is possibility for flicker to occur.

The waveforms of [Figure 15 on page 24](#) to [Figure 18 on page 27](#) are showing line inversion mode.

### 8.1.16 Command: temp-filter

**Table 24. Temp-filter - digital temperature filter command bit description**

Bit	Symbol	Value	Description
7 to 1	-	1101001	fixed value
0	TFE		digital temperature filter switch
		0 <sup>[1]</sup>	digital temperature filter disabled; the unfiltered digital value of TD[7:0] is immediately available for the readout and $V_{LCD}$ compensation, see <a href="#">Section 8.4.7 on page 32</a>
		1	digital temperature filter enabled

[1] Default value.

### 8.2 Possible display configurations

The PCA8543 is a versatile peripheral device designed to interface between any microcontroller to a wide variety of LCD segment or dot matrix displays (see [Figure 3](#)). It can directly drive any static or multiplexed LCD containing up to four backplanes and up to 60 segments.

The display configurations possible with the PCA8543 depend on the number of active backplane outputs required. A selection of possible display configurations is given in [Table 25](#).

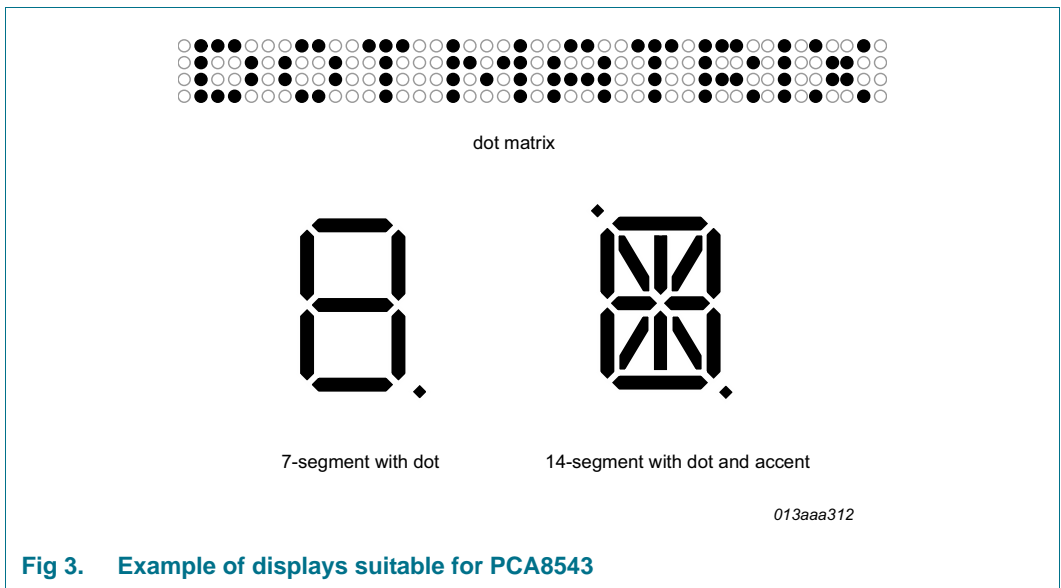

Fig 3. Example of displays suitable for PCA8543

Table 25. Selection of possible display configurations

Number of				
Backplanes	Icons	Digits/Characters		Dot matrix/ Elements
		7-segment <sup>[1]</sup>	14-segment <sup>[2]</sup>	
4	240	30	15	240 dots (4 × 60)
2	120	15	7	120 dots (2 × 60)
1	60	7	3	60 dots (1 × 60)

[1] 7 segment display has 8 elements including the decimal point.

[2] 14 segment display has 16 elements including decimal point and accent dot.

All of the display configurations in [Table 25](#) can be implemented in the typical systems shown in [Figure 4](#) (internal V<sub>LCD</sub>) and in [Figure 5](#) (external V<sub>LCD</sub>).

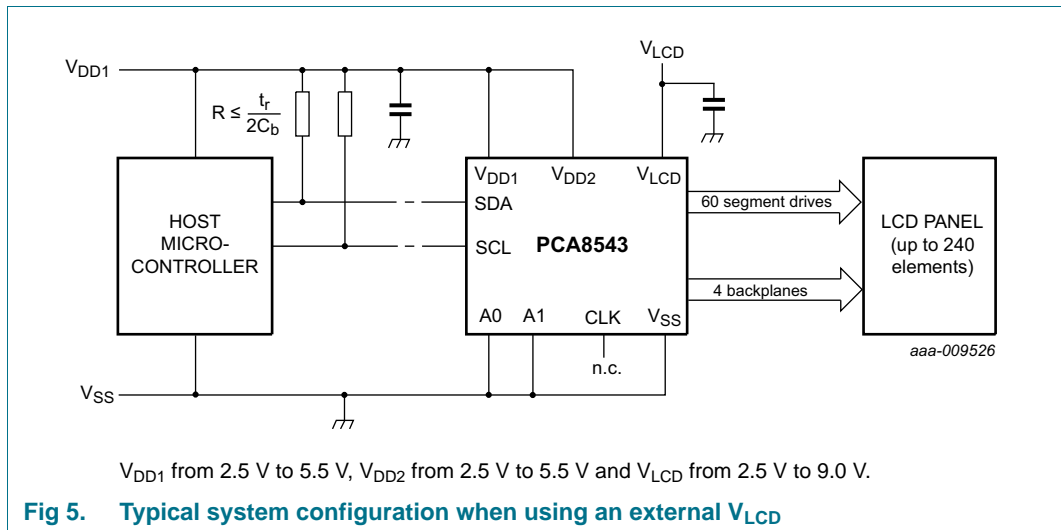
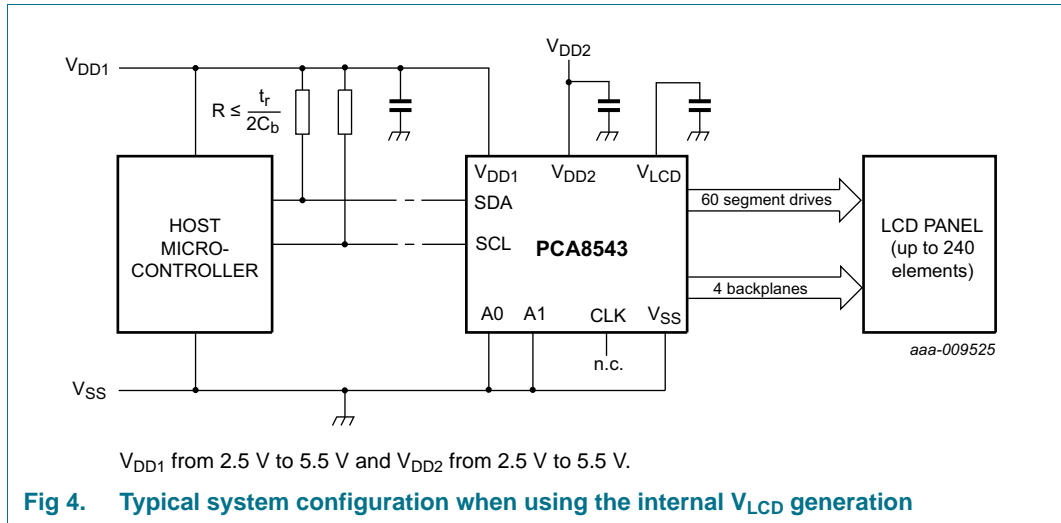

The host microcontroller maintains the two line I<sup>2</sup>C-bus communication channel with the PCA8543. The appropriate biasing voltages for the multiplexed LCD waveforms are generated internally. The only other connections required to complete the system are the power supplies ( $V_{DD1}$ ,  $V_{DD2}$ ,  $V_{SS}$ ,  $V_{LCD}$ ), the external capacitors, and the LCD panel selected for the application.

The minimum recommended values for external capacitors on  $V_{DD1}$ ,  $V_{DD2}$ , and  $V_{LCD}$  are nominal 100 nF. When using bigger capacitors, especially on the  $V_{LCD}$ , the generated ripple will be consequently smaller. However it will take longer for the internal charge pump to reach the target  $V_{LCD}$  voltage first.

If  $V_{DD1}$  and  $V_{DD2}$  are connected externally, the capacitors on  $V_{DD1}$  and  $V_{DD2}$  can be replaced by a single capacitor with a minimum value of 200 nF.

**Remark:** In the case of insufficient decoupling, ripple of  $V_{DD1}$  and  $V_{DD2}$  will create additional  $V_{LCD}$  ripple. The ripple on  $V_{LCD}$  can be reduced by making the  $V_{SS}$  connection as low-ohmic as possible. Excessive ripple on  $V_{LCD}$  may cause flicker on the display.

## 8.3 Start-up and shut-down

### 8.3.1 Power-On Reset (POR)

After power-on the PCA8543 has to be initialized by sending the two bytes of the initialize command (see [Section 8.1.1](#) and [Table 6](#)).

1. All backplane and segment outputs are set to  $V_{SS}$ .
2. Selected drive mode is: 1:4 with  $\frac{1}{4}$  bias.
3. Input and output bank selectors are reset.
4. The I<sup>2</sup>C-bus interface is initialized.
5. The data pointer is cleared (set logic 0).
6. The Internal oscillator is running; no clock signal is available on pin CLK; pin CLK is in 3-state.
7. Temperature measurement is enabled.
8. Temperature filter is disabled.
9. The internal  $V_{LCD}$  voltage generation is disabled. The charge pump is switched off.
10. The  $V_{LCD}$  temperature compensation is enabled.
11. The display is disabled.

The state after initialization is shown in [Table 26](#).

**Table 26. Reset states**

*Bits labeled - are undefined at power-on.*

Command name	Bits							
	7	6	5	4	3	2	1	0
oscillator-ctrl	1	1	0	0	1	1	0	0
charge-pump-ctrl	1	1	0	0	0	0	0	0
temp-msr-ctrl	1	1	0	0	1	0	1	1
temp-comp-SLA	0	0	0	1	1	0	0	0
temp-comp-SLB	0	0	1	0	0	0	0	0
temp-comp-SLC	0	0	1	0	1	0	0	0
temp-comp-SLD	0	0	1	1	0	0	0	0
set-VPR-MSB	0	1	0	0	0	0	0	0
set-VPR-LSB	0	1	0	1	0	0	0	0
display-enable	0	0	1	1	1	0	0	0
set-MUX-mode	0	0	0	0	0	1	0	0
set-bias-mode	1	1	0	0	0	1	0	0
load-data-pointer	1	0	0	0	0	0	0	0
frame-frequency	0	1	1	0	1	1	1	0
input-bank-select	0	0	0	0	1	0	0	0
output-bank-select	0	0	0	1	0	0	0	0
write-RAM-data	-	-	-	-	-	-	-	-

**Table 26. Reset states ...continued**  
*Bits labeled - are undefined at power-on.*

Command name	Bits							
	7	6	5	4	3	2	1	0
temp-read	0	1	0	0	0	0	0	0
invmode_CPF_ctrl	1	1	0	1	0	1	0	0
temp-filter	1	1	0	1	0	0	1	0

**Remark:** Do not transfer data on the I<sup>2</sup>C-bus for at least 1 ms after a power-on to allow the reset action to complete.

The first command sent to the device after the power-on event must be the initialize command (see [Section 8.1.1 on page 6](#)).

After Power-On Reset (POR) and before enabling the display, the RAM content should be brought to a defined status

- by clearing it (setting it all logic 0) or
- by writing meaningful content (for example, a graphic)

otherwise unwanted display artifacts may appear on the display.



### 8.3.2 Recommended start-up sequences

This chapter describes how to proceed with the initialization of the chip in different application modes.

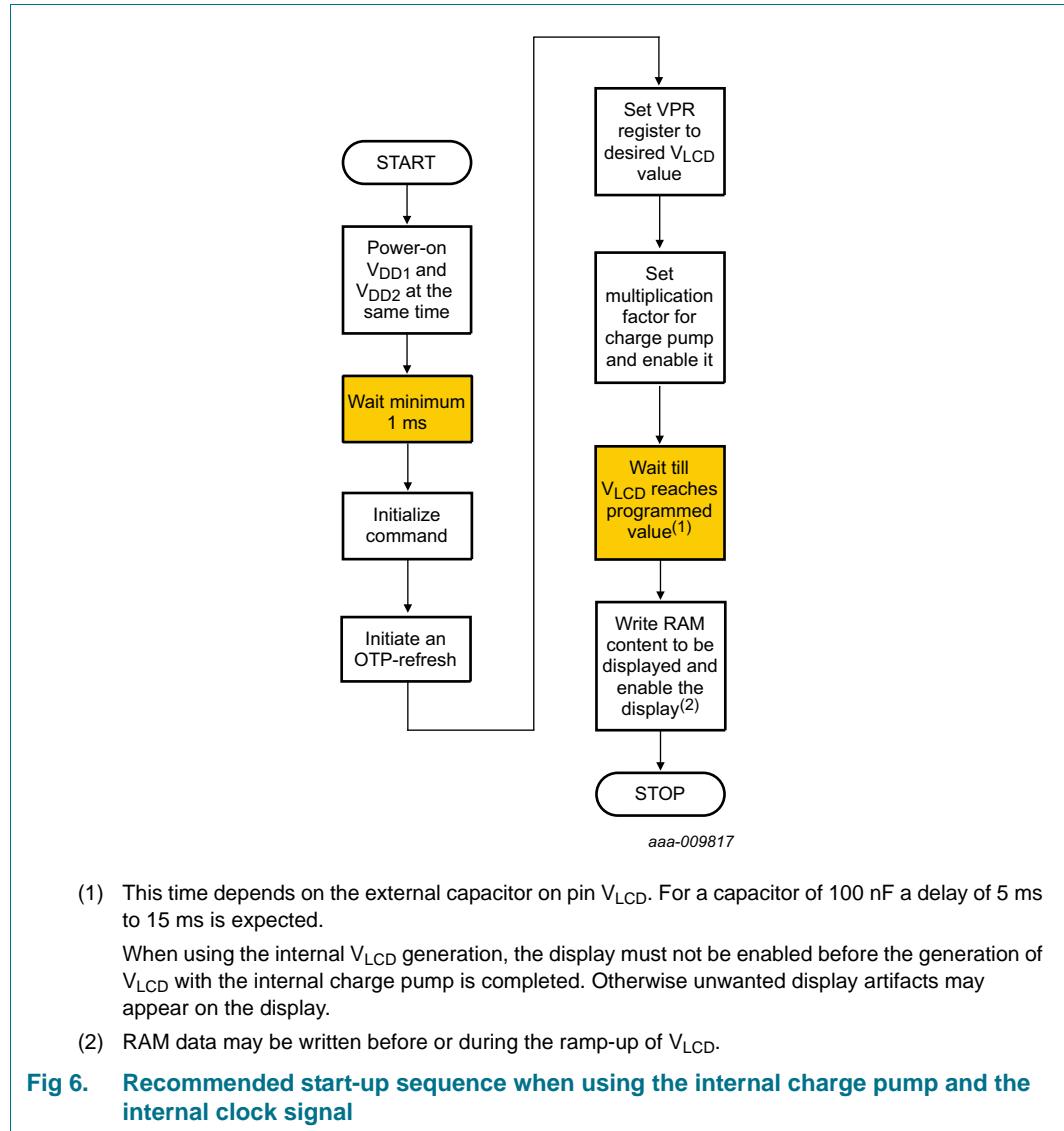

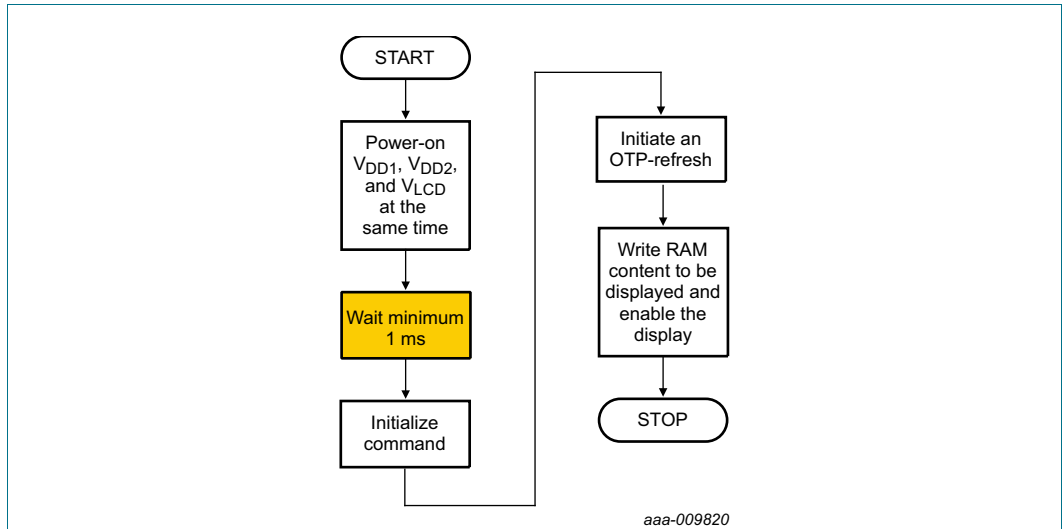

**Fig 7. Recommended start-up sequence when using an external supplied V<sub>LCD</sub> and the internal clock signal**

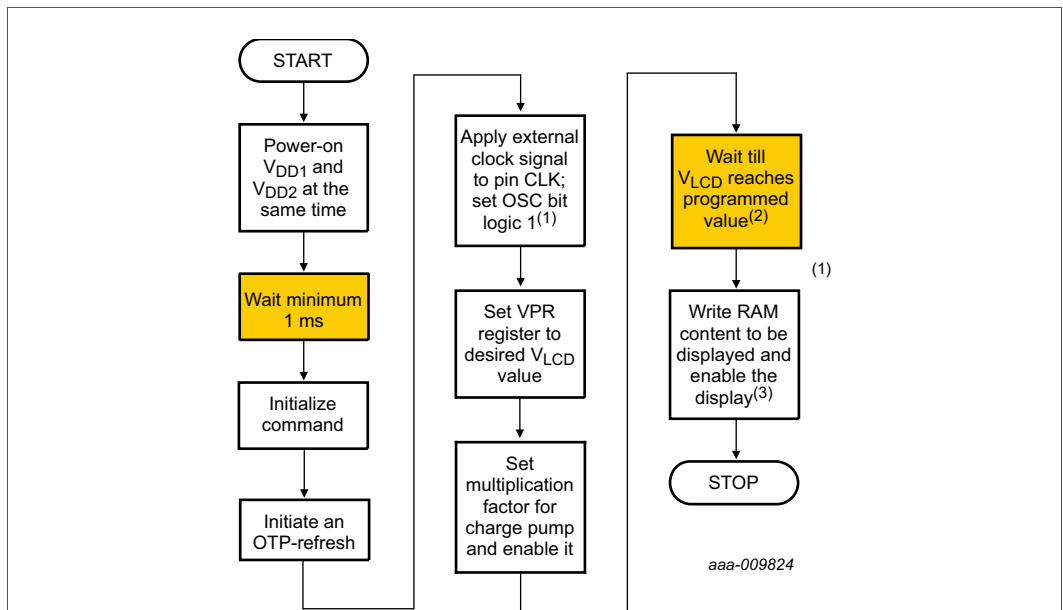

- (1) The external clock signal can be applied after the generation of the V<sub>LCD</sub> voltage as well.
- (2) This time depends on the external capacitor on pin V<sub>LCD</sub>. For a capacitor of 100 nF a delay of 5 ms to 15 ms is expected.
- (3) RAM data may be written before or during the ramp-up of V<sub>LCD</sub>.

**Fig 8. Recommended start-up sequence when using the internal charge pump and an external clock signal**

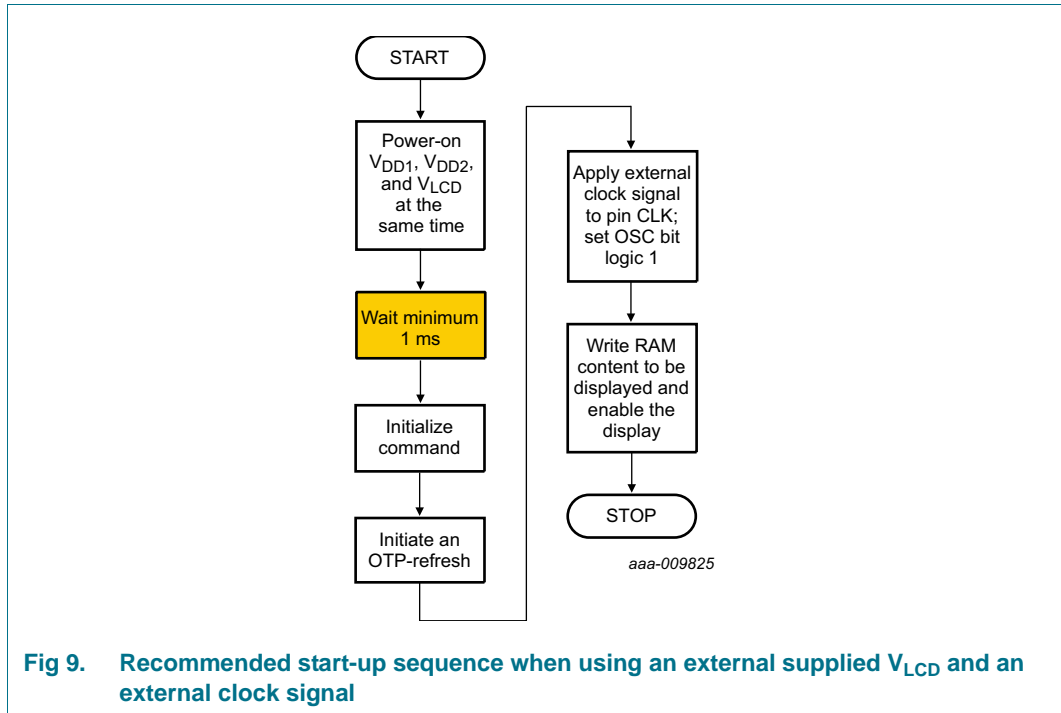

Fig 9. Recommended start-up sequence when using an external supplied  $V_{LCD}$  and an external clock signal

### 8.3.3 Recommended power-down sequences

With the following sequences, the PCA8543 can be set to a state of minimum power consumption, called power-down mode.

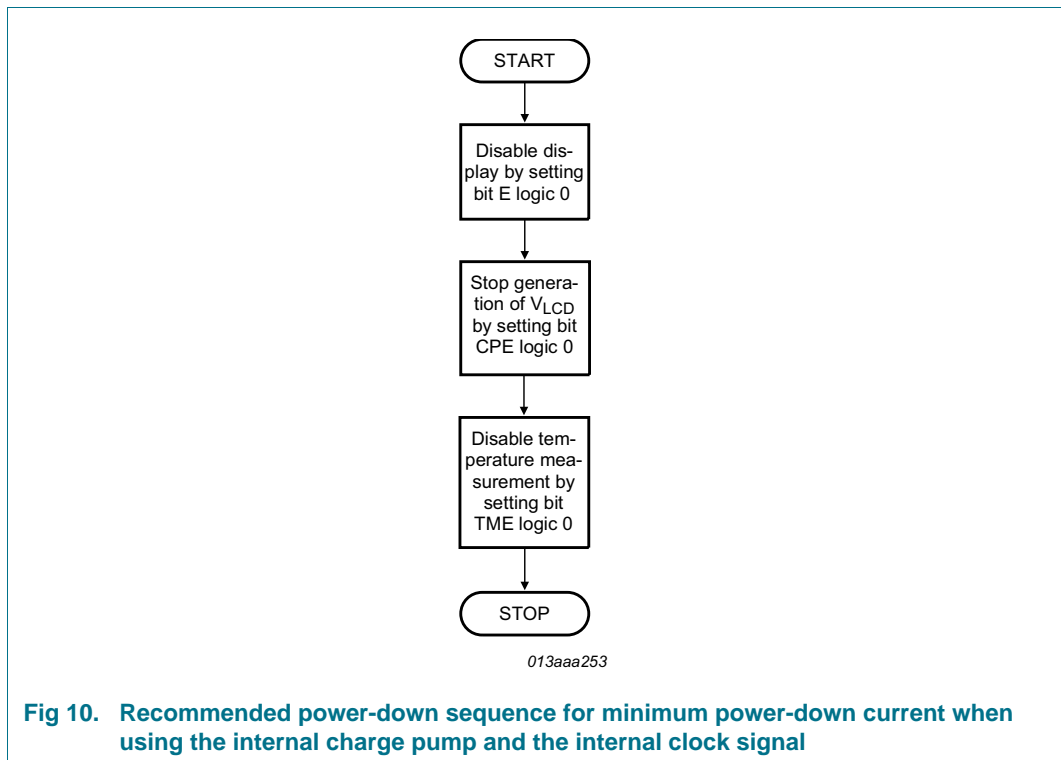
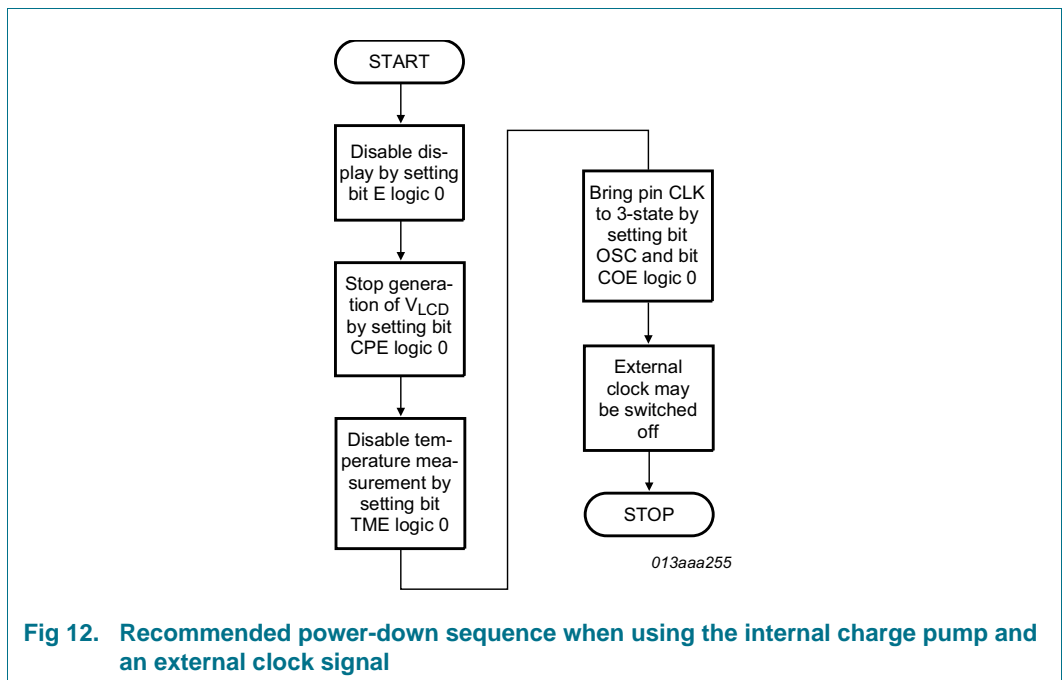
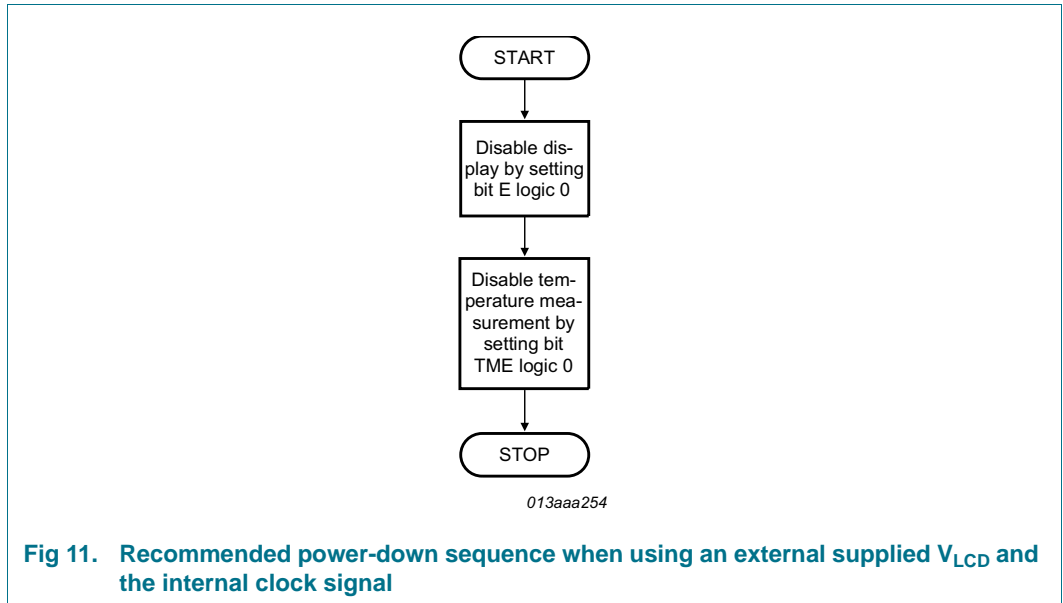
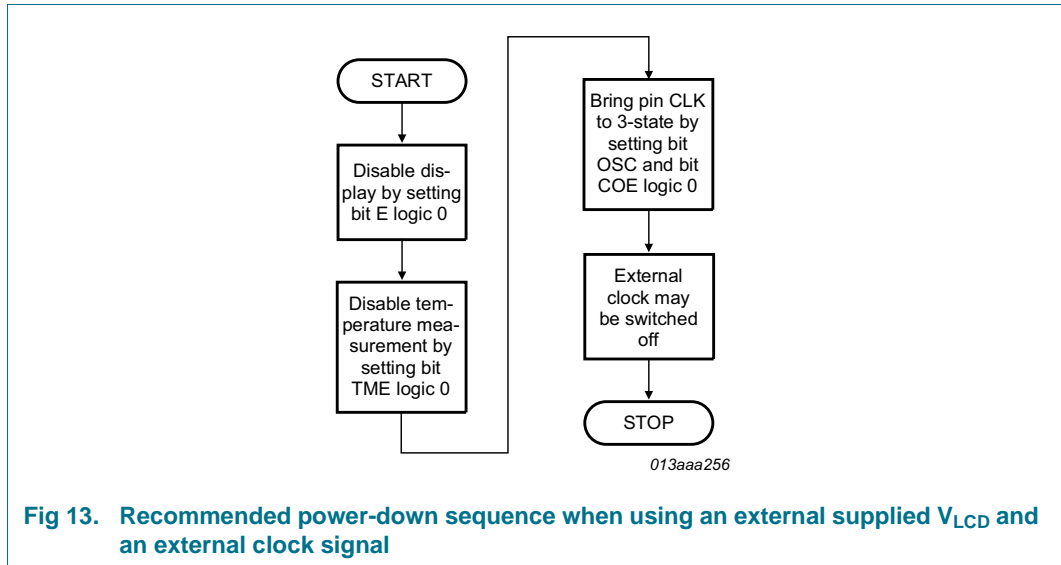

Fig 10. Recommended power-down sequence for minimum power-down current when using the internal charge pump and the internal clock signal





**Fig 13. Recommended power-down sequence when using an external supplied  $V_{LCD}$  and an external clock signal**

**Remark:** It is necessary to run the power-down sequence before removing the supplies. Depending on the application, care must be taken that no other signals are present at the chip input or output pins when removing the supplies (refer to [Section 10 on page 47](#)). Otherwise it may cause unwanted display artifacts. The PCA8543 will not be damaged by uncontrolled removal of supply voltages

**Remark:** Static voltages across the liquid crystal display can build up when the external LCD supply voltage ( $V_{LCD}$ ) is on while the IC supply voltage ( $V_{DD1}$  or  $V_{DD2}$ ) is off, or vice versa. It may cause unwanted display artifacts. To avoid such artifacts, external  $V_{LCD}$ ,  $V_{DD1}$ , and  $V_{DD2}$  must be applied or removed together.

**Remark:** A clock signal must always be supplied to the device when the device is active; removing the clock may freeze the LCD in a DC state, which is not suitable for the liquid crystal. It is recommended to first disable the display and afterwards to remove the clock signal.

## 8.4 LCD voltage

### 8.4.1 LCD voltage selector

The LCD voltage selector co-ordinates the multiplexing of the LCD in accordance with the selected LCD drive configuration. The operation of the voltage selector is controlled by the set-bias-mode command (see [Table 15 on page 9](#)) and the set-MUX-mode command (see [Table 14 on page 9](#)).

Intermediate LCD biasing voltages are obtained from an internal voltage divider. The biasing configurations that apply to the preferred modes of operation, together with the biasing characteristics as functions of  $V_{LCD}$  and the resulting discrimination ratios (D), are given in [Table 27](#).

Discrimination is a term which is defined as the ratio of the  $V_{on(RMS)}$  and  $V_{off(RMS)}$  across a segment. It can be thought of as a measurement of contrast.

Table 27. LCD drive modes: summary of characteristics

LCD drive mode	Number of:		LCD bias configuration	$\frac{V_{off(RMS)}}{V_{LCD}}$	$\frac{V_{on(RMS)}}{V_{LCD}}$	$D = \frac{V_{on(RMS)}}{V_{off(RMS)}} [1]$	$V_{LCD} [2]$
	Backplanes	Levels					
static	1	2	static	0	1	$\infty$	$V_{on(RMS)}$
1:2 multiplex	2	3	$\frac{1}{2}$	0.354	0.791	2.236	$2.828 \times V_{off(RMS)}$
1:2 multiplex	2	4	$\frac{1}{3}$	0.333	0.745	2.236	$3.0 \times V_{off(RMS)}$
1:2 multiplex <sup>[3]</sup>	2	5	$\frac{1}{4}$	0.395	0.729	1.845	$2.529 \times V_{off(RMS)}$
1:4 multiplex <sup>[3]</sup>	4	3	$\frac{1}{2}$	0.433	0.661	1.527	$2.309 \times V_{off(RMS)}$
1:4 multiplex	4	4	$\frac{1}{3}$	0.333	0.577	1.732	$3.0 \times V_{off(RMS)}$
1:4 multiplex <sup>[3]</sup>	4	5	$\frac{1}{4}$	0.331	0.545	1.646	$3.024 \times V_{off(RMS)}$

[1] Determined from Equation 3.

[2] Determined from Equation 2.

[3] In these examples the discrimination factor and hence the contrast ratios are smaller. The advantage of these LCD drive modes is a power saving from a reduction of the LCD voltage  $V_{LCD}$ .

A practical value for  $V_{LCD}$  is determined by equating  $V_{off(RMS)}$  with a defined LCD threshold voltage ( $V_{th(off)}$ ), typically when the LCD exhibits approximately 10 % contrast. In the static drive mode a suitable choice is  $V_{LCD} > 3V_{th(off)}$ .

Bias is calculated by  $\frac{1}{1+a}$ , where the values for a are

a = 1 for  $\frac{1}{2}$  bias

a = 2 for  $\frac{1}{3}$  bias

a = 3 for  $\frac{1}{4}$  bias

The RMS on-state voltage ( $V_{on(RMS)}$ ) for the LCD is calculated with Equation 1:

$$V_{on(RMS)} = V_{LCD} \sqrt{\frac{a^2 + 2a + n}{n \times (1 + a)^2}} \tag{1}$$

where  $V_{LCD}$  is the resultant voltage at the LCD segment and where the values for n are

n = 1 for static mode

n = 2 for 1:2 multiplex

n = 4 for 1:4 multiplex

The RMS off-state voltage ( $V_{off(RMS)}$ ) for the LCD is calculated with Equation 2:

$$V_{off(RMS)} = V_{LCD} \sqrt{\frac{a^2 - 2a + n}{n \times (1 + a)^2}} \tag{2}$$

Discrimination is the ratio of  $V_{on(RMS)}$  to  $V_{off(RMS)}$  and is determined from Equation 3:

$$D = \frac{V_{on(RMS)}}{V_{off(RMS)}} = \sqrt{\frac{a^2 + 2a + n}{a^2 - 2a + n}} \tag{3}$$

It should be noted that  $V_{LCD}$  is sometimes referred as the LCD operating voltage.

8.4.1.1 Electro-optical performance

Suitable values for  $V_{on(RMS)}$  and  $V_{off(RMS)}$  are dependent on the LCD liquid used. The RMS voltage, at which a pixel will be switched on or off, determine the transmissibility of the pixel.

For any given liquid, there are two threshold values defined. One point is at 10 % relative transmission (at  $V_{th(off)}$ ) and the other at 90 % relative transmission (at  $V_{th(on)}$ ), see [Figure 14](#). For a good contrast performance, the following rules should be followed:

$$V_{on(RMS)} \geq V_{th(on)} \tag{4}$$

$$V_{off(RMS)} \leq V_{th(off)} \tag{5}$$

$V_{on(RMS)}$  and  $V_{off(RMS)}$  are properties of the display driver and are affected by the selection of a, n (see [Equation 1](#) to [Equation 3](#)) and the  $V_{LCD}$  voltage.

$V_{th(off)}$  and  $V_{th(on)}$  are properties of the LCD liquid and can be provided by the module manufacturer.

It is important to match the module properties to those of the driver in order to achieve optimum performance.

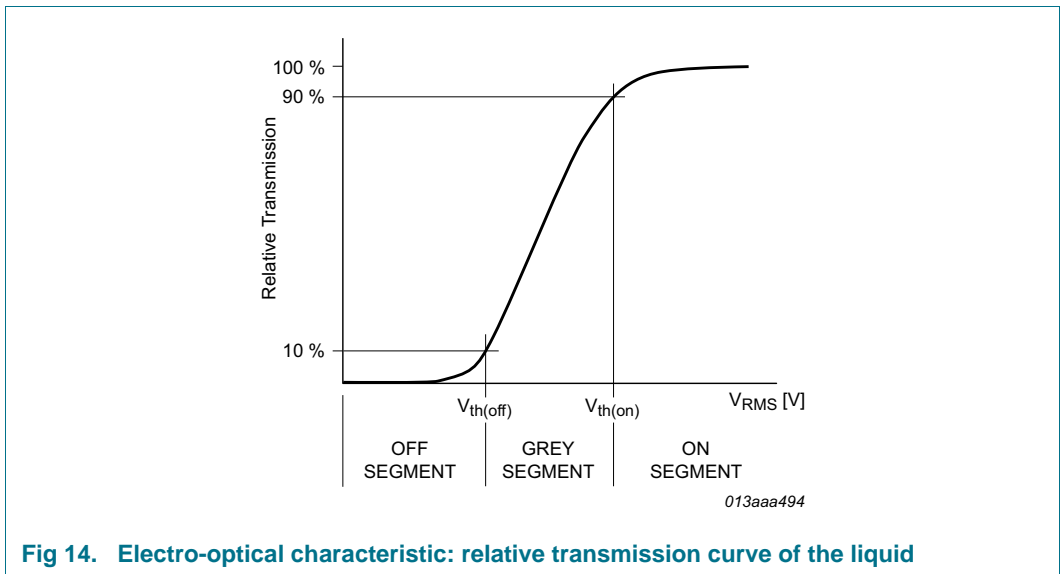
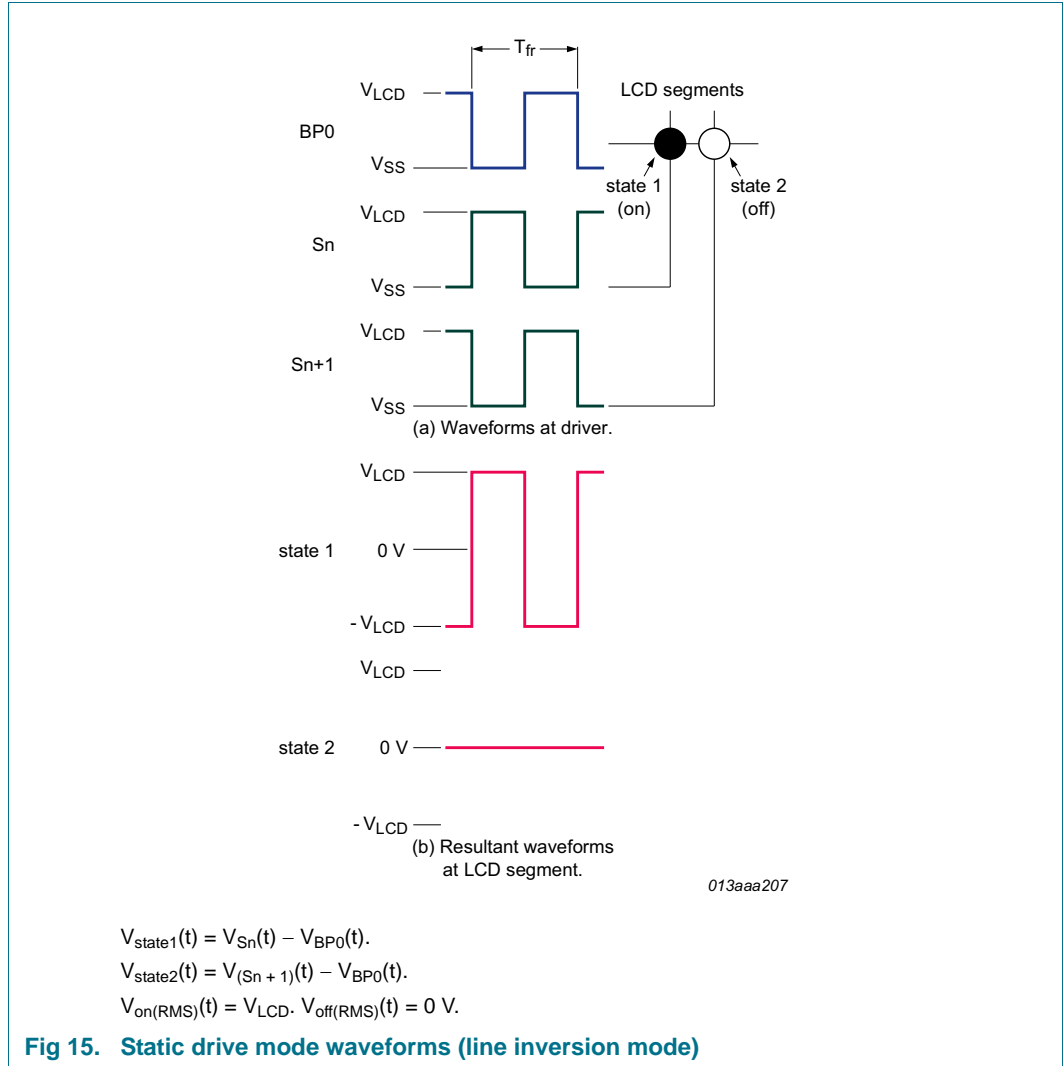

Fig 14. Electro-optical characteristic: relative transmission curve of the liquid

8.4.2 LCD drive mode waveforms

8.4.2.1 Static drive mode

The static LCD drive mode is used when a single backplane is provided in the LCD.





8.4.2.2 1:2 Multiplex drive mode

When two backplanes are provided in the LCD, the 1:2 multiplex mode applies. The PCA8543 allows the use of 1/2 bias or 1/3 bias in this mode as shown in Figure 16 and Figure 17.

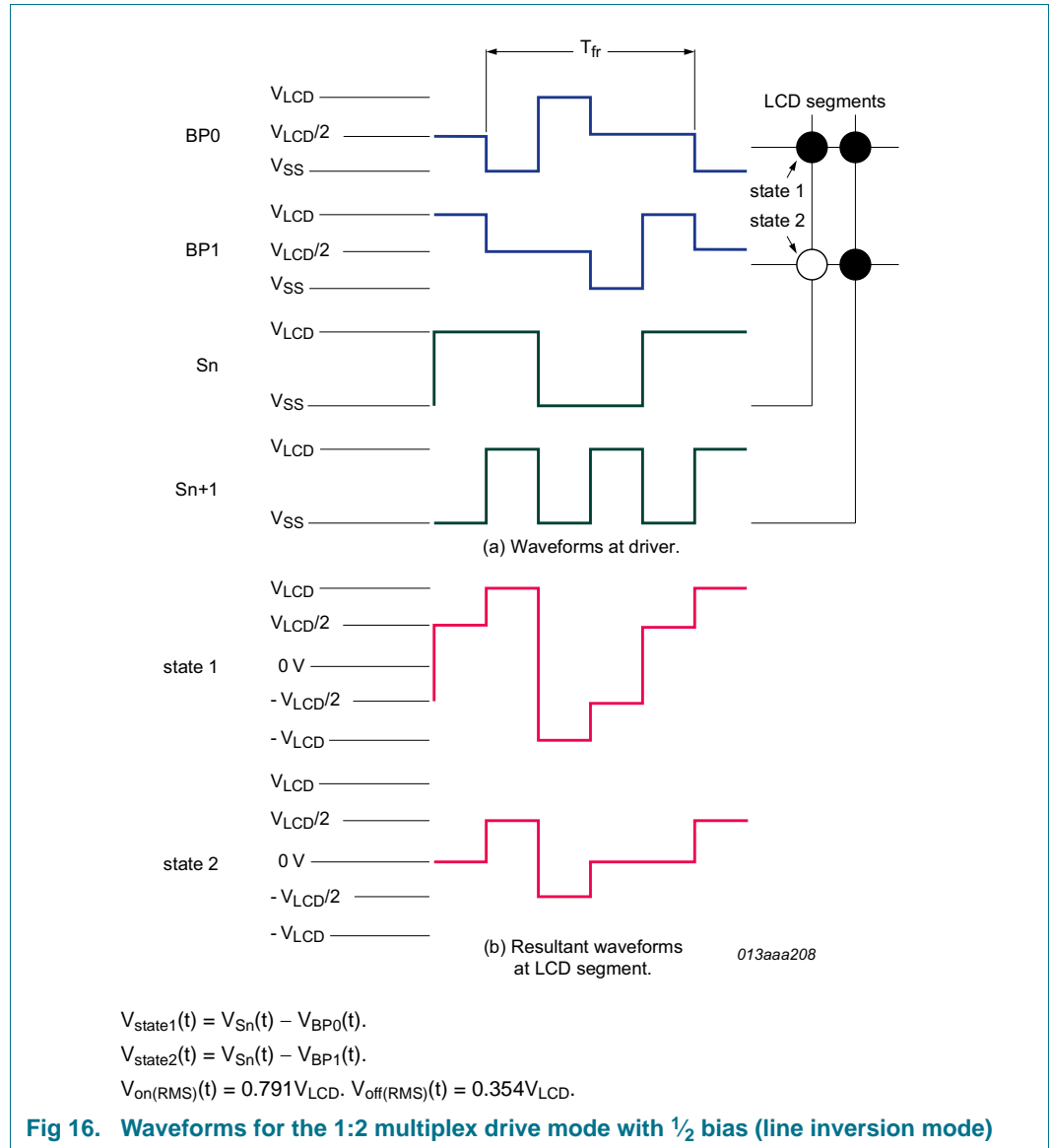

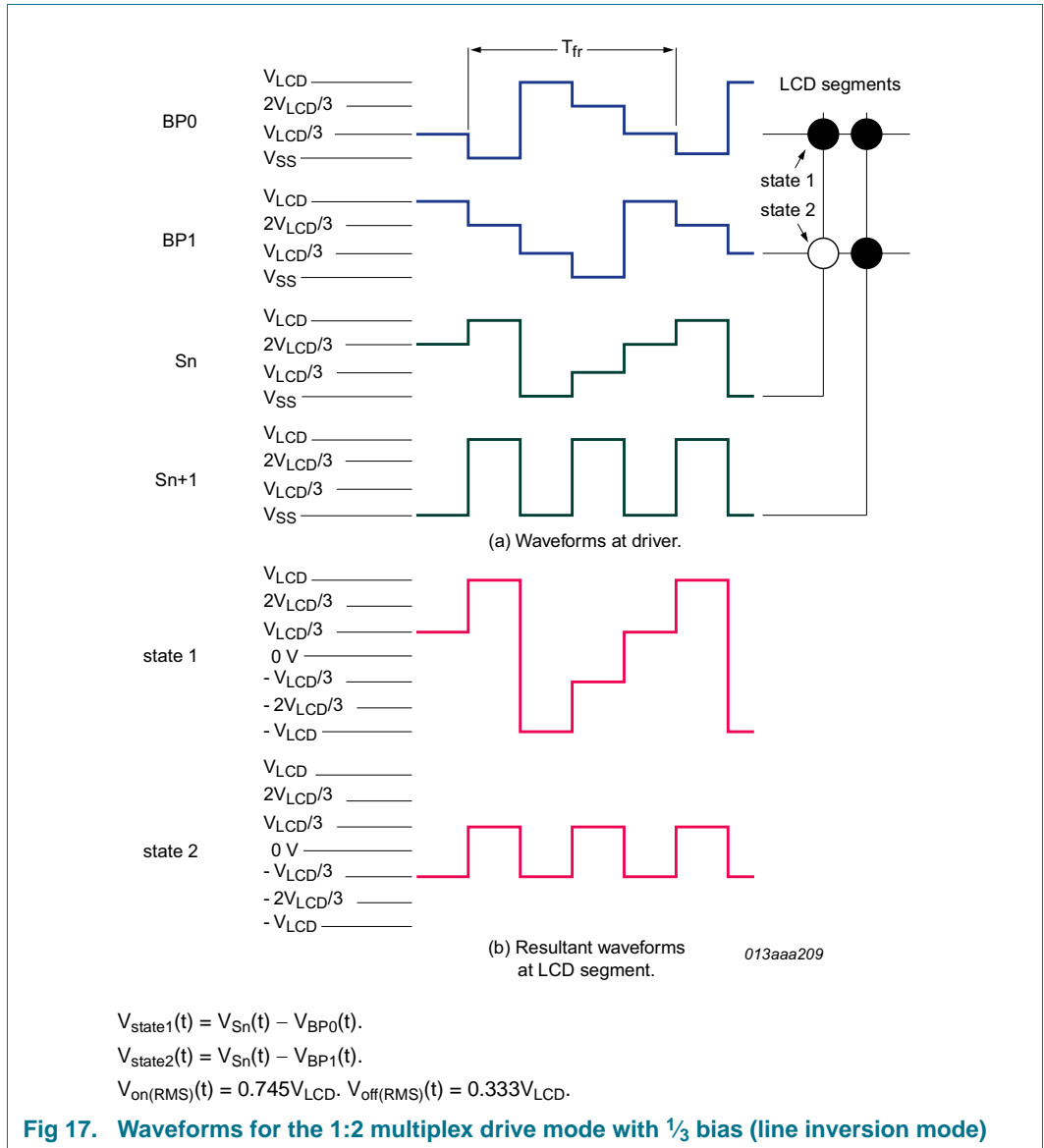

8.4.2.3 1:4 Multiplex drive mode

When four backplanes are provided in the LCD, the 1:4 multiplex drive mode applies, as shown in Figure 18.

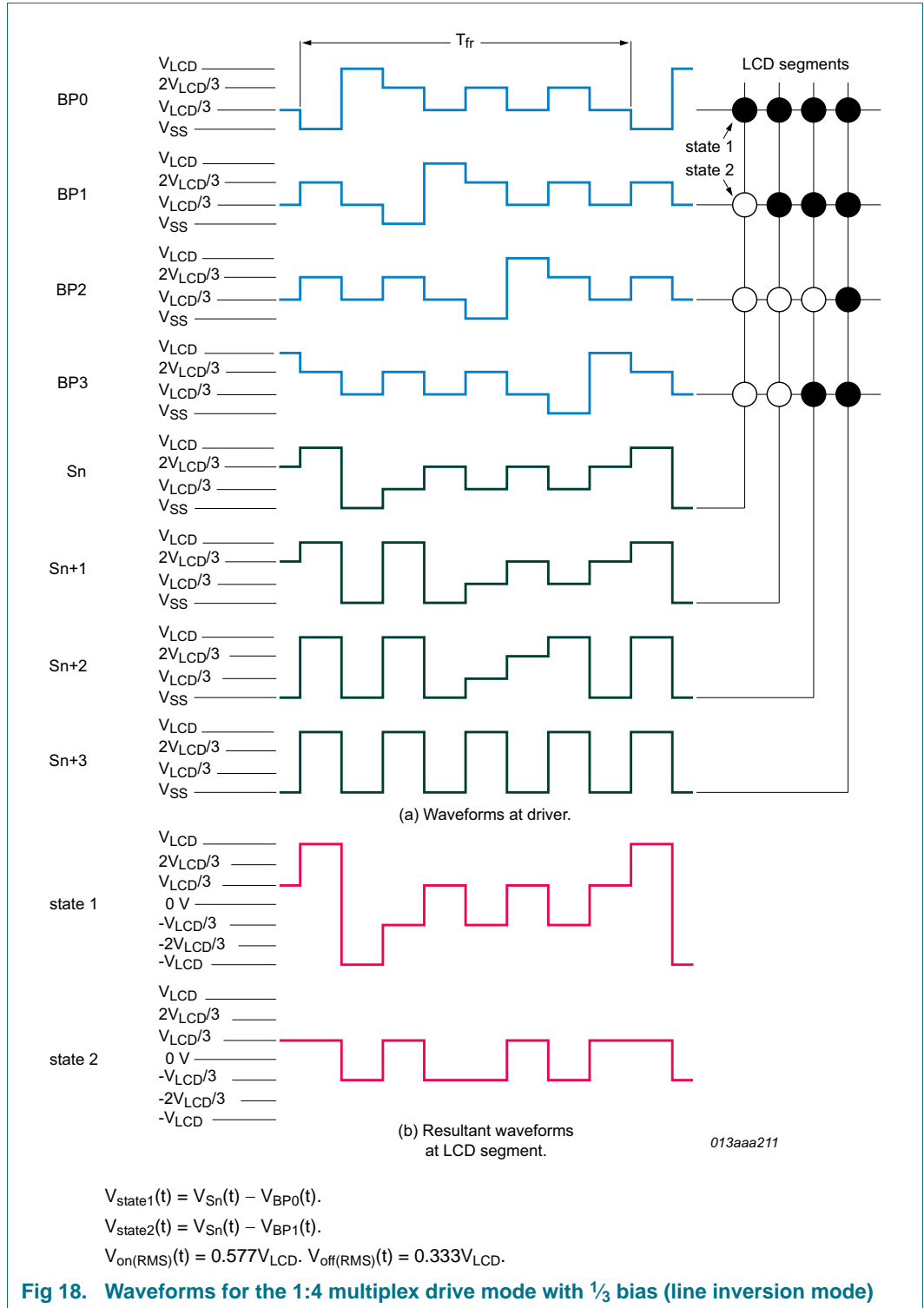

8.4.3 V<sub>LCD</sub> generation

V<sub>LCD</sub> can be generated and controlled on the chip by using software commands. When the internal charge pump is used, the programmed V<sub>LCD</sub> is available on pin V<sub>LCD</sub>. The charge pump generates a V<sub>LCD</sub> of up to 3 × V<sub>DD2</sub>.

The charge pump can be enabled or disabled with the CPE bit (see [Table 9 on page 8](#)). With bit CPC, the charge pump multiplier setting can be configured.

The final value of V<sub>LCD</sub> is a combination of the programmed VPR[7:0] value and the output of the temperature compensation block, VT[7:0]. The system is shown in [Figure 19](#).

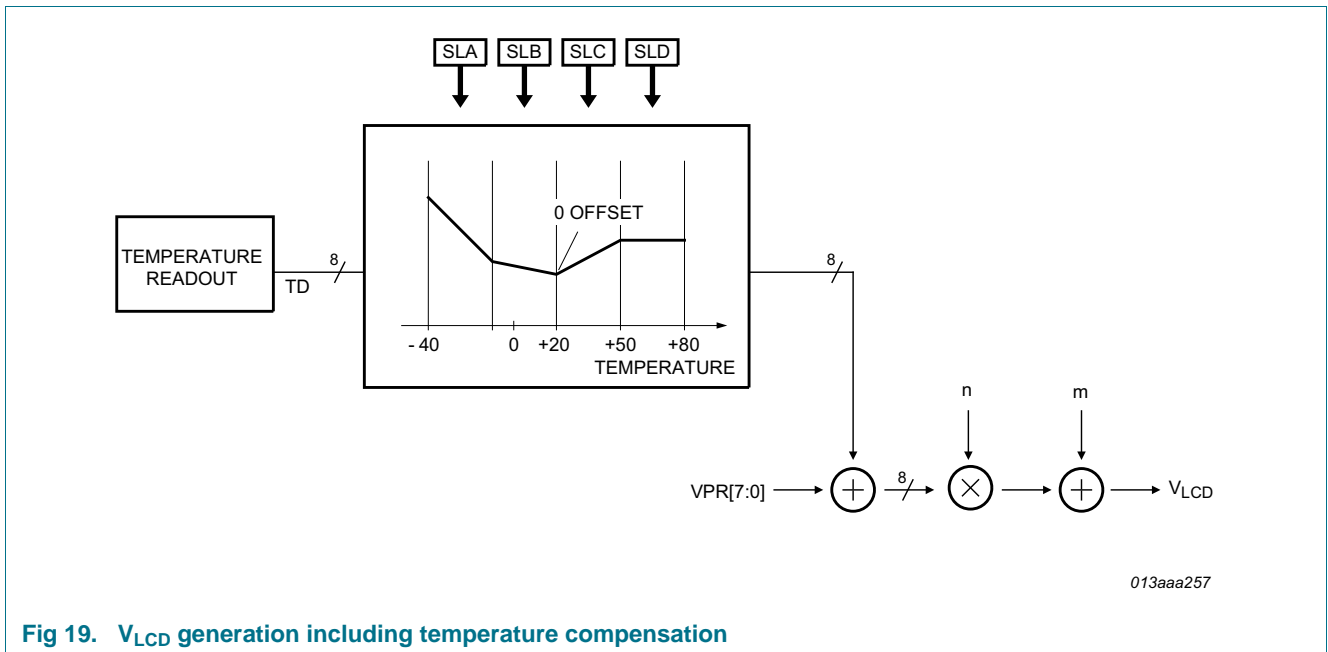

Fig 19. V<sub>LCD</sub> generation including temperature compensation

In [Equation 6](#) the main parameters are the programmed digital value term and the compensated temperature term.

$$V_{LCD} = [VPR[7:0] + VT[7:0]] \times n + m \tag{6}$$

1. VPR[7:0] is the binary value of the programmed voltage.
2. VT[7:0] is the binary value of the temperature compensated voltage. Its value comes from the temperature compensation block and is a two's complement which has the value 0h at 20 °C.
3. m and n are fixed values (see [Table 28](#)).

Table 28. Parameters of V<sub>LCD</sub> generation

Symbol	Value	Unit
m	3	V
n	0.03	V

[Figure 20](#) shows how V<sub>LCD</sub> changes with the programmed value of VPR[7:0].

The charge pump has to be configured (via bit CPC) properly to obtain the desired voltage range. For example, if  $V_{DD2} = 3.0\text{ V}$  and CPC is set to  $2 \times V_{DD2}$  (logic 0) then the maximum theoretical value that the charge pump can reach is  $V_{LCD} = 6.0\text{ V}$ . But in reality, lower values will be reached due to internal resistances, see [Section 8.4.5](#). So, if the requested value for  $V_{LCD} = 7.0\text{ V}$  then the charge pump has to be configured with CPC set to  $3 \times V_{DD2}$  (logic 1).

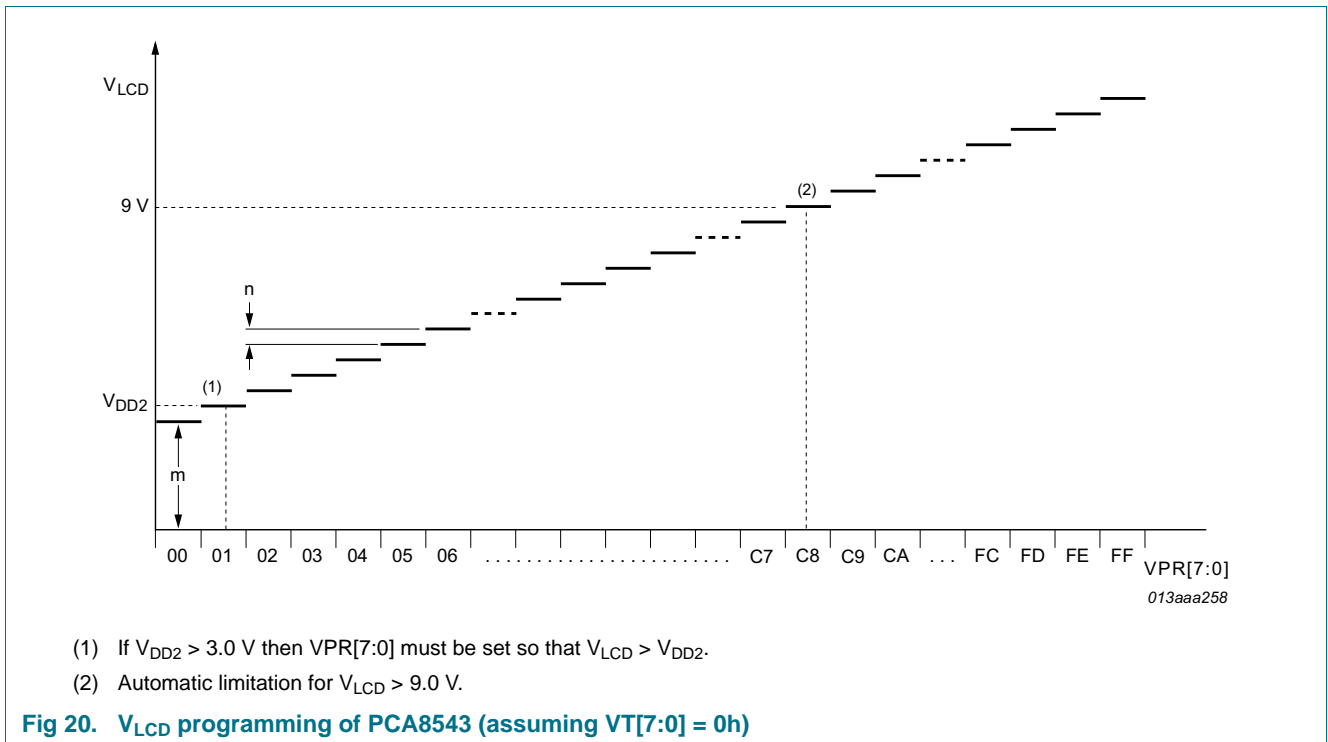

Programmable range of VPR[7:0] is from 0h to FFh. This would allow achieving  $V_{LCD} > 9.0\text{ V}$ , but the PCA8543 has a built-in automatic limitation of  $V_{LCD}$  at 9.0 V.

If  $V_{DD2}$  is higher than 3.0 V, then it is important that VPR[7:0] is set to a value such that the resultant  $V_{LCD}$  (including the temperature correction of  $VT[7:0]$ ) is higher than  $V_{DD2}$ .

**8.4.4 External  $V_{LCD}$  supply**

$V_{LCD}$  can be directly supplied to the  $V_{LCD}$  pin. In this case, the internal charge pump must not be enabled otherwise a high current may occur on pin  $V_{DD2}$  and pin  $V_{LCD}$ . When  $V_{LCD}$  is supplied externally, no internal temperature compensation occurs on this voltage even if bit TCE is set logic 1 (see [Section 8.4.8 on page 33](#)). The  $V_{LCD}$  voltage which is supplied externally will be available at the segments and backplanes of the device through the chosen bias system. Also programming the VPR[7:0] bit field has no effect on the  $V_{LCD}$  which is externally supplied.

**8.4.5 Charge pump driving capability**

[Figure 21](#) illustrates the main factor determining how much current the charge pump can deliver.

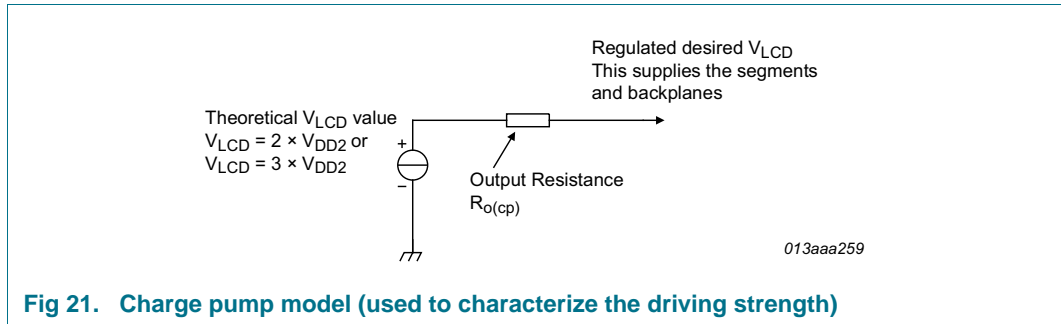

**Fig 21. Charge pump model (used to characterize the driving strength)**

The output resistance of the charge pump is specified in [Table 36 on page 49](#). With these values, it can be calculated how much current the charge pump can drive under certain conditions.

Example: Assuming that the normal operation point is at 25 °C with V<sub>LCD</sub> = 7.0 V and V<sub>DD2</sub> = 5.0 V and the charge pump is set to 2 × V<sub>DD2</sub>. Then the theoretical value of V<sub>LCD</sub> is 10.0 V and the desired one is 7.0 V. The difference between the theoretical maximum value and desired one is 3.0 V. The charge pump resistance is nominally 0.85 kΩ. [Equation 7](#) shows the possible current that the charge pump could deliver:

$$I_{load} = \Delta V_{LCD} / R_{o(cp)} \tag{7}$$

The result of this example is:  $I_{load} = 3.0 \text{ V} / 0.85 \text{ k}\Omega = 3.5 \text{ mA}$

In cases where no extreme driving capability is needed, a command is available for decreasing the charge pump frequency (see [Table 23 on page 12](#)) and thus reducing the total current consumption. If the charge pump frequency is halved, then the driving capability is halved as well, whereas the output resistance doubles.

### 8.4.6 Charge pump frequency settings and power efficiency

The PCA8543 offers the possibility to use different frequency settings for the charge pump. Bit CPF controls the frequency at which the charge pump is running (see [Table 23 on page 12](#)). This frequency has a direct influence on the current consumption of the IC but also on the charge pump driving capability. Using a lower charge pump frequency decreases the current consumption and the driving capability.

The power efficiency of the charge pump determines in certain applications which frequency settings to choose for the CPF bit. Concerning the example shown in [Figure 22](#): The current consumption was measured with

- charge pump set to 2 × V<sub>DD2</sub>
- V<sub>DD2</sub> = 3.0 V
- VPR[7:0] set to maximum to obtain the highest possible V<sub>LCD</sub> with this setup, which is close to 6.0 V

The current load on pin V<sub>LCD</sub> determines the output power delivered by the IC:

$$P_o = I_{load} \times V_{LCD} \tag{8}$$

The current consumption on pin V<sub>DD2</sub> determines the input power taken by the IC:

$$P_i = I_{DD2} \times V_{DD2} \tag{9}$$

The ratio between these two numbers determines the charge pump power efficiency:

$$\eta_p = P_o / P_i \tag{10}$$

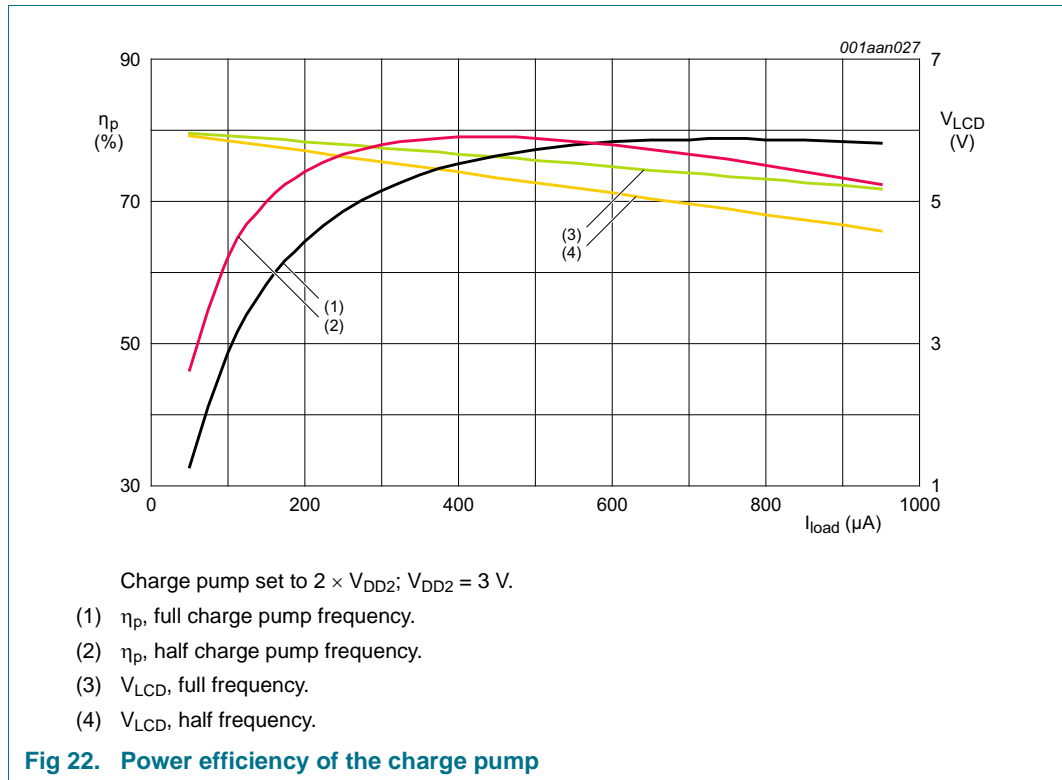

Loading the charge pump with higher currents decreases the output voltage. This decrease is determined by the charge pump driving capability, respectively by the output resistance of the charge pump (see [Table 36 on page 49](#)).

The power efficiency calculation is only valid when the charge pump is running at its maximum peak frequency and regulates the generated  $V_{LCD}$  voltage with full speed. In this case, the ripple on the  $V_{LCD}$  voltage equals the internal charge pump frequency. Approximately, this could also be calculated with the parameter of the output resistance of the charge pump (see [Table 36 on page 49](#)), the load current, and the voltage needed to be provided by using [Equation 7 on page 30](#). This value of  $I_{load}$  is close to the value of the load current needed for the application.

If the application runs with  $V_{DD2} = 3.0 \text{ V}$ , the load currents are up to  $400 \mu\text{A}$  (DC measured), and the  $V_{LCD}$  generated voltages are up to  $5.0 \text{ V}$ , then - concerning power efficiency - it would be the best to have a charge pump frequency set to half frequency.

If it is desired to change the charge pump frequency, it is recommended to make a graph like [Figure 22](#) and understand what the application requirements are. This would basically imply to find out what would be the maximum  $V_{LCD}$  requirements and what would be the maximum load currents required. Then it can be decided which is the best setting of bit CPF.

Tuning the charge pump frequency might be a difficult task to do. It requires good knowledge of the application in which the IC is being used; therefore, NXP is recommending to keep the CPF bit set logic 0 to have the maximum charge pump frequency, thus having the maximum driving strength.

### 8.4.7 Temperature readout

The PCA8543 has a built-in temperature sensor which provides an 8 bit digital value, TD[7:0], of the ambient temperature. This value can be read through the I<sup>2</sup>C interface (see [Figure 41 on page 46](#)). The actual temperature is determined from TD[7:0] using [Equation 11](#):

$$T (^{\circ}\text{C}) = 0.9375 \times TD[7:0] - 40 \tag{11}$$

The measurement needs about 5 ms to complete. it is repeated periodically as soon as bit TME is set logic 1 (see [Table 10 on page 8](#)). The time between measurements is linked to the system clock and hence varies with changes in the chosen frame frequency, see [Table 29](#).

**Table 29. Temperature measurement update rate**

Selected frame frequency	Temperature measurement update rate
60 Hz	3.3 s
200 Hz	1 s
300 Hz	0.67 s

Due to the nature of a temperature sensor, oscillations on the  $V_{LCD}$  may occur. To avoid it, a filter has been implemented in PCA8543. The system is shown in [Figure 23](#).

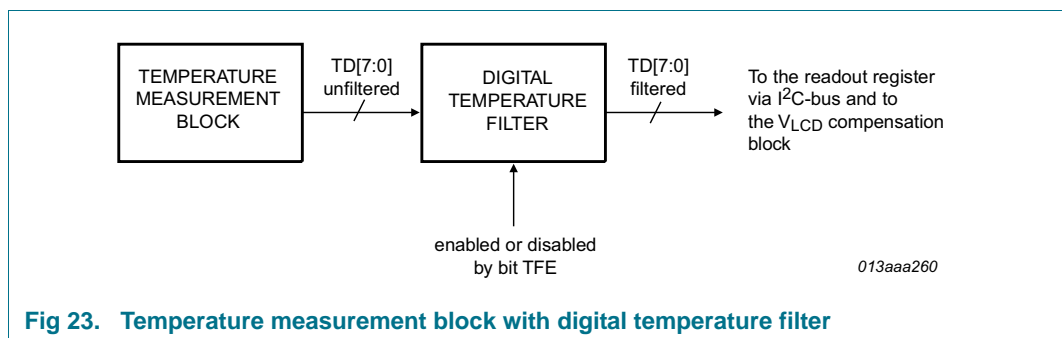

**Fig 23. Temperature measurement block with digital temperature filter**

Like any other filtering, the digital temperature filter (see [Figure 23](#)) introduces a certain delay in the measurement of temperature. This behavior is illustrated in [Figure 24](#).



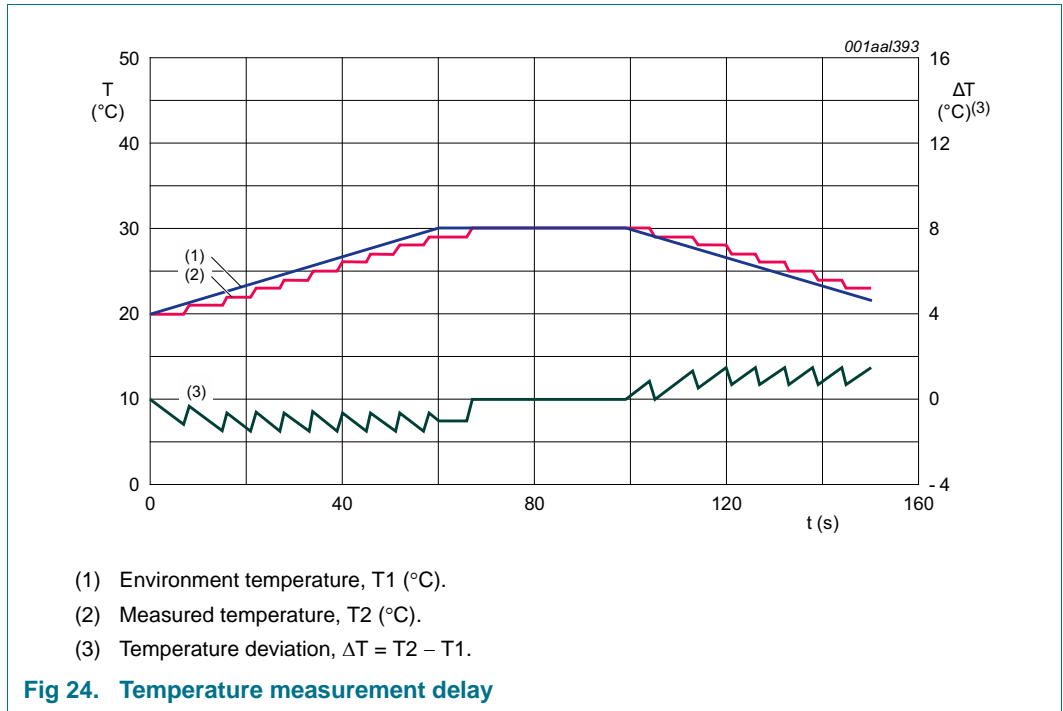

This delay may cause undesired effects at start-up when the environment temperature may be different than the reset value of the PCA8543 which is 20 °C. In this case, it takes up to 30 s until the correct measured temperature value will be available. A control bit, TFE, is implemented to enable or disable the digital temperature filter. This bit is set logic 0 by default which means that the filter is disabled and the unfiltered environment temperature value is available to calculate the desired  $V_{LCD}$ .

#### 8.4.8 Temperature compensation of $V_{LCD}$

Due to the temperature dependency of the liquid crystal viscosity, the LCD controlling voltage  $V_{LCD}$  might have to be adjusted at different temperatures to maintain optimal contrast. The temperature behavior of the liquid comes from the LCD manufacturer. The slope has to be set to compensate for the liquid behavior. Internal temperature compensation may be enabled via bit TCE.

The ambient temperature range is split up into four equally sized regions and a different temperature coefficient can be applied to each (see [Figure 25](#)). Each coefficient can be selected from a choice of eight different slopes. Each one of these coefficients (see [Table 30](#)) may be independently selected via the temp-comp-SLA to temp-comp-SLD commands (see [Table 5 on page 6](#)).

**Table 30. Temperature coefficients**

SLA[2:0] to SLD[2:0] value	Corresponding slope factor (mV/°C)	Temperature coefficients MA, MB, MC, MD <sup>[1]</sup>
000 <sup>[2]</sup>	0	0.00
001	-4	-0.125
010	-8	-0.25
011	-16	-0.5
100	-40	-1.25
101	+4	0.125
110	+8	0.25
111	+16	0.5

[1] The relationship between the temperature coefficients MA to MD and the slope factor is derived from the following equation: 
$$Mx = \frac{0.9375}{0.03} \times \frac{slope}{1000}$$

[2] Default value.

The slope factors imply a linear correction, however the implementation is set in steps of 30 mV (parameter n in [Table 28 on page 28](#)).

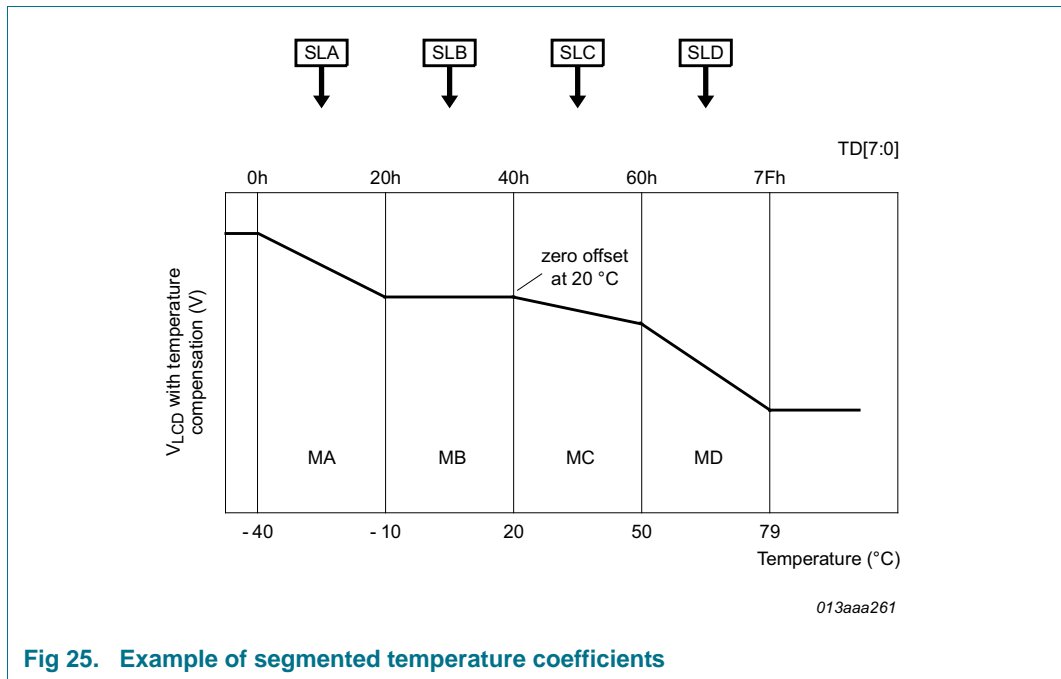

**Fig 25. Example of segmented temperature coefficients**

**Remark:** After reset,  $V_{LCD}$  is fixed because the VPR[7:0] bit field is reset logic 0. The value of VT[7:0] is generated by the reset value of TD[7:0] (40h, representing 20 °C). Temperature compensation is implemented by adding an offset VT[7:0] to the VPR[7:0] value. VT[7:0] is a two's complement number that equals 0h at 20 °C. The final result for  $V_{LCD}$  calculation is an 8-bit positive number (see [Equation 6 on page 28](#)).

**Remark:** Care must be taken that the ranges of VPR[7:0] and VT[7:0] do not cause clipping and hence undesired results. The device will not permit overflow or underflow and will clamp results to either end of the range.

The  $V_{offset(LCD)}$  value can be calculated with the equations given in [Table 31](#):

$$V_{offset(LCD)} = m \times V_T \tag{12}$$

**Table 31. Calculation of the temperature compensated voltage  $V_T$**

Temperature range	TD[7:0]	Offset equation for $V_T$
$T \leq -40\text{ °C}$	0h	$V_T = -32 \times MA - 32 \times MB$
$-40\text{ °C} \leq T \leq -10\text{ °C}$	0h to 20h	$V_T = (TD[7:0] - 32) \times MA - 32 \times MB$
$-10\text{ °C} < T \leq 20\text{ °C}$	21h to 40h	$V_T = (TD[7:0] - 64) \times MB$
$20\text{ °C} < T \leq 50\text{ °C}$	41h to 60h	$V_T = (TD[7:0] - 64) \times MC$
$50\text{ °C} < T < 80\text{ °C}$	61h to 7Eh	$V_T = (TD[7:0] - 96) \times MD + 32 \times MC$
$80\text{ °C} \leq T$	7Fh <sup>[1]</sup>	$V_T = 31 \times MD + 32 \times MC$

[1] No temperature compensation is possible above 80 °C. Above this value, the system maintains the compensation value from 80 °C.

**Example:** Assumed that  $T_{amb} = -8\text{ °C}$ ;  $TD[7:0] = 22h$ ;  $MB = -0.5$ :

$$V_{offset(LCD)} = m \times V_T = m \times (TD[7:0] - 64) \times MB = 30mV \times ((34 - 64) \times -0.5) = 30mV \times -30 \times -0.5 = 450mV \tag{13}$$

The  $VT[7:0]$  term is calculated using the digital temperature value  $TD[7:0]$  which is provided by the temperature measurement block ([Section 8.4.7](#)). Therefore the accuracy of the temperature measurement block ( $T_{acc}$ , see [Table 36 on page 49](#)) will be directly translated to the LCD voltage deviation  $\Delta V_{LCD}$ .

Since  $VT[7:0] = f[T, slope]$  and  $T_{acc} = \pm 6\text{ °C}$  then  $\Delta V_T = T_{acc} \times slope$ , where slope has one of the possible values specified in [Table 30](#). This term will be added to the total LCD voltage deviation  $\Delta V_{offset(LCD)tot}$  over the temperature range. So the total  $V_{LCD}$  offset will be:  $\Delta V_{offset(LCD)tot} = \Delta V_{LCD} + \Delta V_T$ .

## 8.5 Oscillator

The internal logic and LCD drive signals of the PCA8543 are timed by a frequency  $f_{clk}$  which either is the built-in oscillator frequency  $f_{osc}$  or equals an external clock frequency.

### 8.5.1 Internal oscillator

When the internal oscillator is used, it is possible to make the clock signal available on pin CLK by using the oscillator-ctrl command (see [Table 8 on page 7](#)). If this is not intended, pin CLK should be left open. At power-on the signal at pin CLK is disabled and pin CLK is in 3-state.

The duty cycle of the output clock provided on the CLK pin is not always 50 : 50. [Table 18 on page 10](#) shows the expected duty cycle for each of the chosen frame frequencies.

**8.5.2 External clock**

In applications where an external clock needs to be applied to the PCA8543, bit OSC (see [Table 8 on page 7](#)) must be set logic 1. In this case pin CLK becomes an input.

The CLK signal is a signal that is fed into the V<sub>DD1</sub> domain so it must have an amplitude equal to the V<sub>DD1</sub> voltage supplied to the chip and be referenced to V<sub>SS</sub>.

The clock frequency (f<sub>clk</sub>) determines the LCD frame frequency f<sub>fr</sub>.

**Remark:** If an external clock is used then this clock signal must always be supplied to the device; removing the clock may freeze the LCD in a DC state, which is not suitable for the liquid crystal. Removal of the clock is possible when following the correct procedures. See [Figure 12 on page 20](#) and [Figure 13 on page 21](#).

**8.5.3 Timing and frame frequency**

The timing of the PCA8543 organizes the internal data flow of the device. It includes the transfer of display data from the display RAM to the display segment outputs. The timing also generates the LCD frame frequency which it derives as an integer division of the clock frequency. The frame frequency is a fixed division of the internal clock or of the frequency applied to pin CLK when an external clock is used:

$$f_{fr} = \frac{f_{clk}}{48} \tag{14}$$

When the internal clock is used, the clock and frame frequency can be programmed by software such that the nominal frame frequency can be chosen in steps of 10 Hz in the range of 60 Hz to 300 Hz (see [Table 18 on page 10](#)). Furthermore the nominal frame frequency is factory-calibrated with an accuracy of ±15 %.

When the internal clock is enabled at pin CLK by using bit COE, the duty ratio of the clock may change when choosing different values for the frame frequency prescaler. [Table 18 on page 10](#) shows the different output duty ratios for each frame frequency prescaler setting.

**8.6 Backplane outputs**

The LCD drive section includes four backplane outputs: BP0 to BP3. The backplane output signals are generated based on the selected LCD multiplex drive mode.

[Table 32](#) describes which outputs are active for each of the multiplex drive modes and what signal is generated.

**Table 32. Mapping of output pins and corresponding output signals with respect to the multiplex driving mode**

Multiplex drive mode	Output pin			
	BP0	BP1	BP2	BP3
	<b>Signal</b>			
1:4	BP0	BP1	BP2	BP3
1:2	BP0	BP1	BP0 <sup>[1]</sup>	BP1 <sup>[1]</sup>
static	BP0	BP0 <sup>[1]</sup>	BP0 <sup>[1]</sup>	BP0 <sup>[1]</sup>

[1] These pins may optionally be connected to the display to improve drive strength. Connect only with the corresponding output pin carrying the same signal. If not required, they can be left open-circuit.

## 8.7 Segment outputs

The LCD drive section includes 60 segment outputs (S0 to S59) which must be connected directly to the LCD. The segment output signals are generated based on the multiplexed backplane signals and with data resident in the display register. When less than 60 segment outputs are required, the unused segment outputs must be left open-circuit.

## 8.8 Display register

The display register holds the display data while the corresponding multiplex signals are generated.

## 8.9 Display RAM

The display RAM is a static  $60 \times 8$ -bit RAM which stores LCD data. Logic 1 in the RAM bit map indicates the on-state of the corresponding LCD element; similarly, logic 0 indicates the off-state.

There is a one-to-one correspondence between

- the bits in the RAM bitmap and the LCD elements
- the RAM columns and the segment outputs
- the RAM rows and the backplane outputs.

The display RAM bit map, [Figure 26](#), shows row 0 to row 7 which correspond with the backplane outputs BP0 to BP3, and column 0 to column 59 which correspond with the segment outputs S0 to S59. The number of rows is twice the number of backplane outputs allowing to use two different RAM banks.

When display data is transmitted to the PCA8543, the display bytes received are stored in the display RAM in accordance with the selected LCD multiplex drive mode. The data is stored as it arrives and does not wait for the acknowledge cycle as with the commands. Depending on the current multiplex drive mode, data is stored singularly, in pairs, or quadruples.

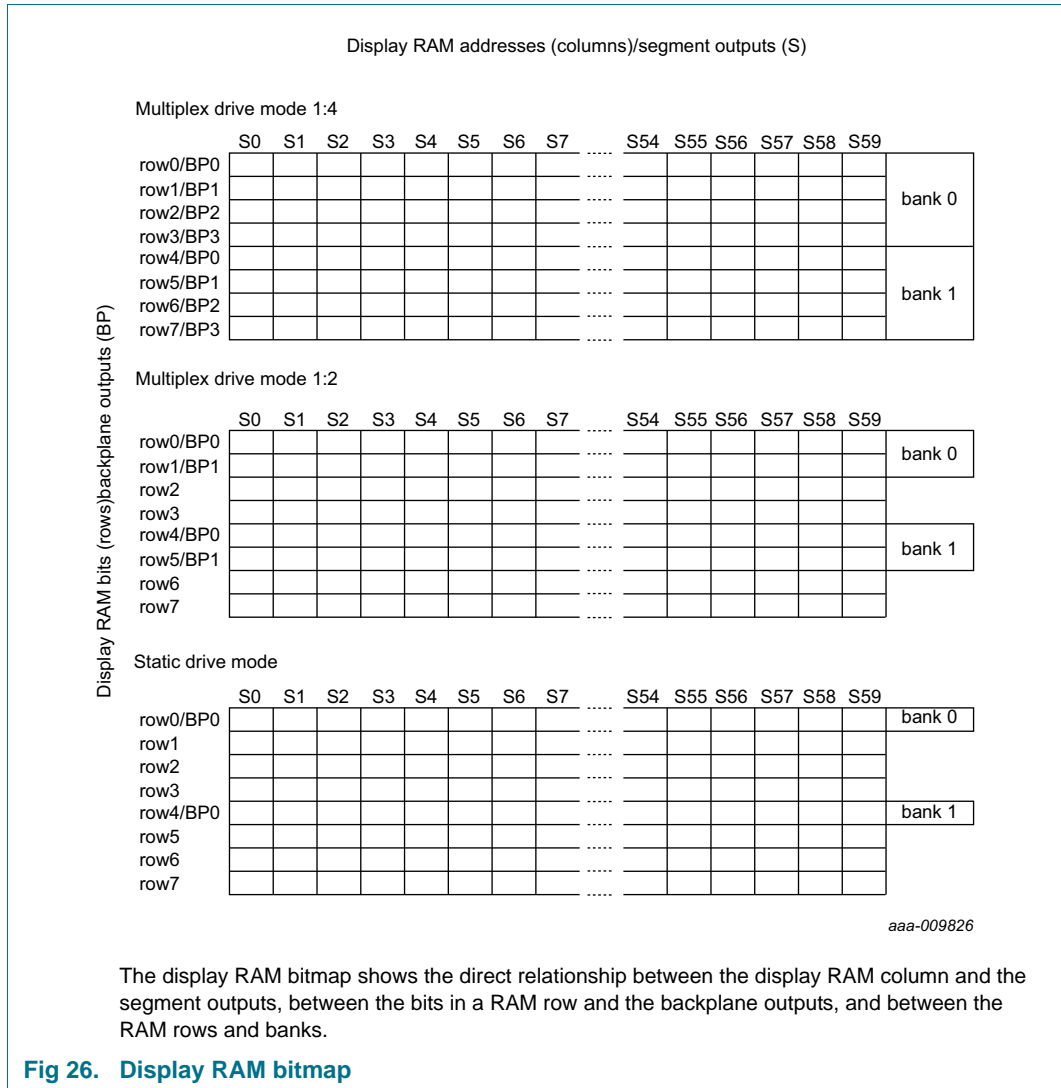

**8.9.1 Data pointer**

The addressing mechanism for the display RAM is realized using the data pointer. It allows the loading of an individual display data byte, or a series of display data bytes into any location of the display RAM. The sequence commences with the initialization of the data pointer by the load-data-pointer command. Following this command, an arriving data byte is stored starting at the display RAM address indicated by the data pointer.

The data pointer is automatically incremented in accordance with the chosen LCD multiplex drive mode configuration. That is, after each byte is stored, the contents of the data pointer are incremented

- by eight (static drive mode)
- by four (1:2 multiplex drive mode)
- by two (1:4 multiplex drive mode)

If the data pointer reaches the end of the RAM row, it is automatically wrapped around to address 0. This means that it can be continuously written to or read from the display RAM.

The data pointer should always be set to an address where the remaining RAM is divisible by eight because odd bits will be discarded (see [Figure 28](#)). This behavior is only shown in static drive mode because the 60 RAM cells cannot be divided by eight without remainder.

If an I<sup>2</sup>C-bus data access is terminated early, then the state of the data pointer is unknown. The data pointer must then be re-written before further RAM accesses.

**8.9.1.1 RAM filling in static drive mode**

In the static drive mode the eight transmitted data bits are placed in eight successive display RAM columns in row 0 (see [Figure 27](#)).

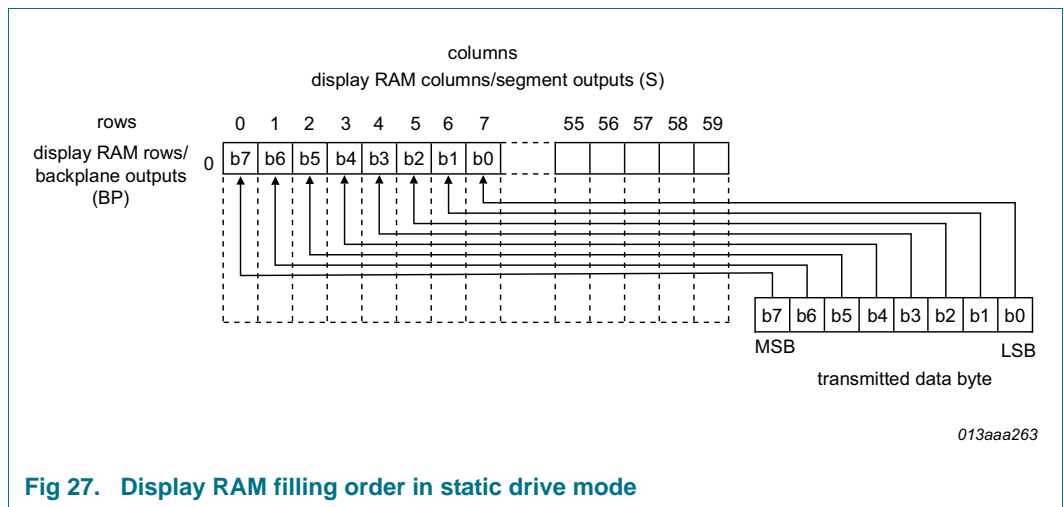

**Fig 27. Display RAM filling order in static drive mode**

In order to fill the whole RAM row, 8 bytes must be sent to the PCA8543, but the last 4 bits from the last byte are discarded, and the data pointer is wrapped around to column 0 to start a possible RAM content update (see [Figure 28](#)).

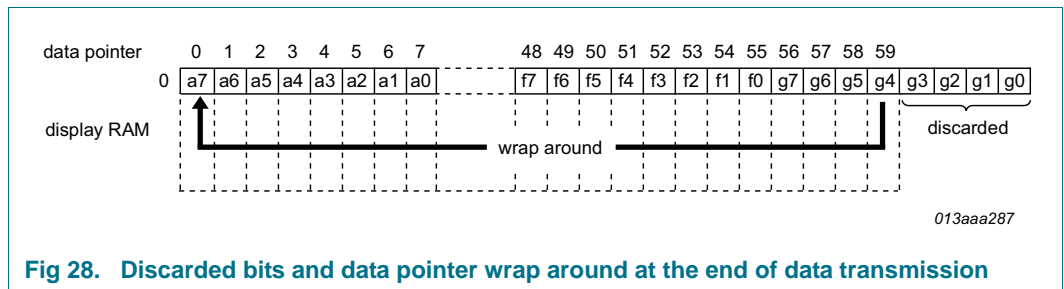

**Fig 28. Discarded bits and data pointer wrap around at the end of data transmission**





8.9.1.3 RAM filling in 1:4 multiplex drive mode

In the 1:4 multiplex drive mode the eight transmitted data bits are placed in two successive display RAM columns of four rows (see Figure 31).

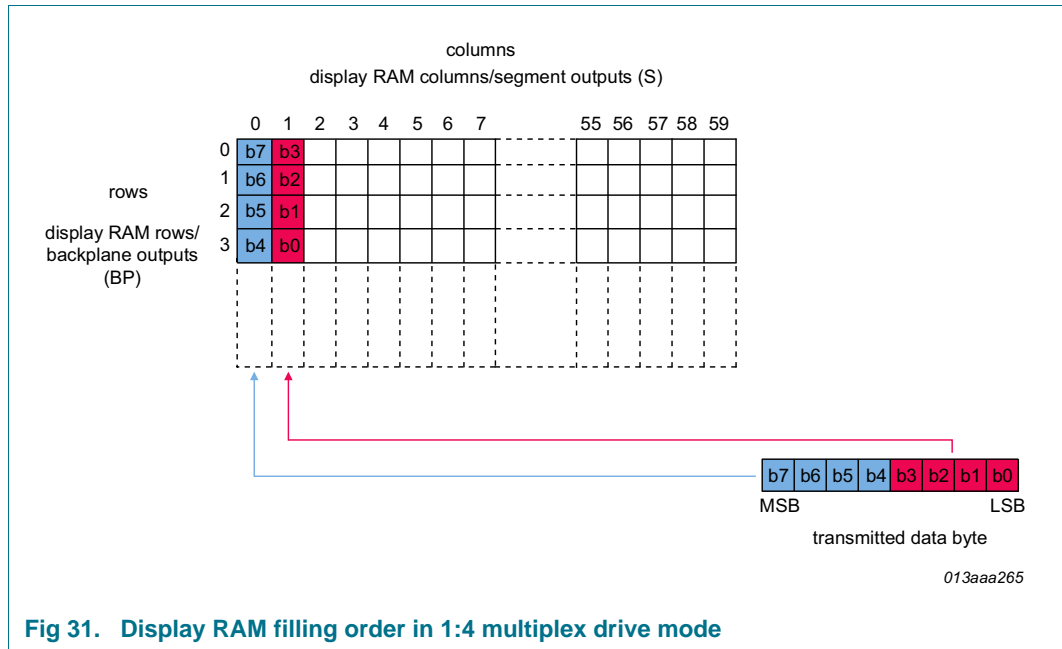

Fig 31. Display RAM filling order in 1:4 multiplex drive mode

In order to fill the whole four RAM rows 30 bytes need to be sent to the PCA8543. After the last byte sent, the data pointer is wrapped around to column 0 to start a possible RAM content update (see Figure 32). Even if a data byte is transmitted during the wrapping of the data pointer, all the bits in the byte will be written correctly.

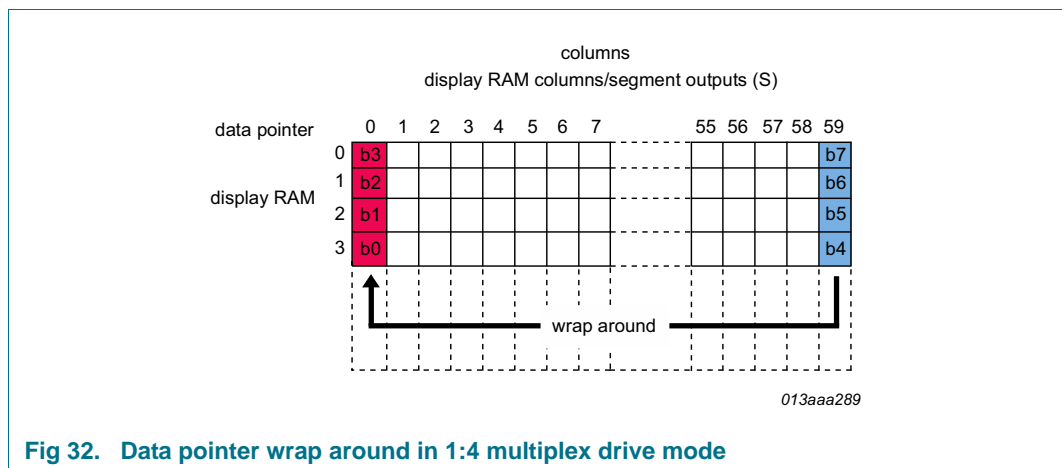

Fig 32. Data pointer wrap around in 1:4 multiplex drive mode

8.9.2 Bank selection

A RAM bank can be thought of as a collection of RAM rows. The PCA8543 includes a RAM bank switching feature.

The RAM bank switching gives the provision for preparing display information in an alternative bank and to be able to switch to it once it is complete. Input and output banks can be set independently from one another with the input-bank-select and the

output-bank-select commands; [Figure 33](#) shows the concept.

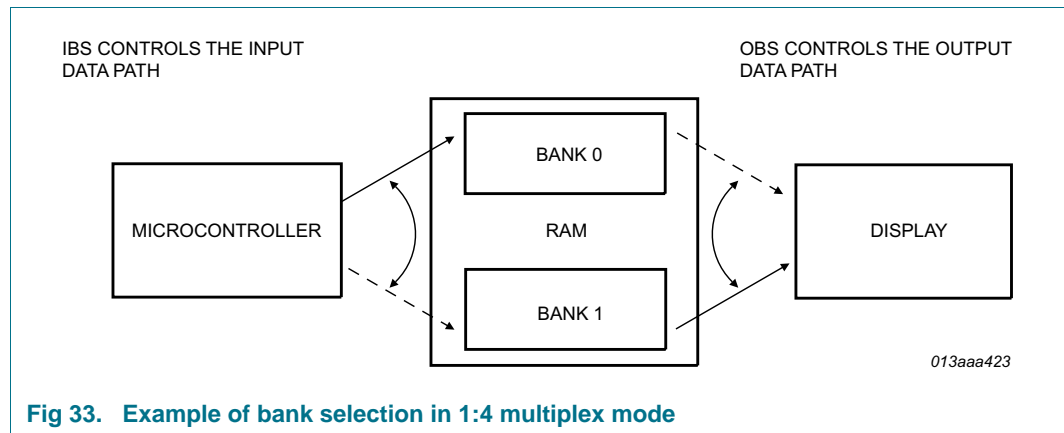

**Fig 33. Example of bank selection in 1:4 multiplex mode**

In [Figure 33](#) an example is shown for 1:4 multiplex drive mode. The displayed data is read from the first four rows of the memory (bank 0), while the transmitted data is stored in the second four rows of the memory (bank 1) which is currently not accessed for the reading. Therefore different content can be loaded into the first and second four RAM rows which will be immediately displayed on the LCD by switching it with the output-bank-select command (see [Figure 34](#)).

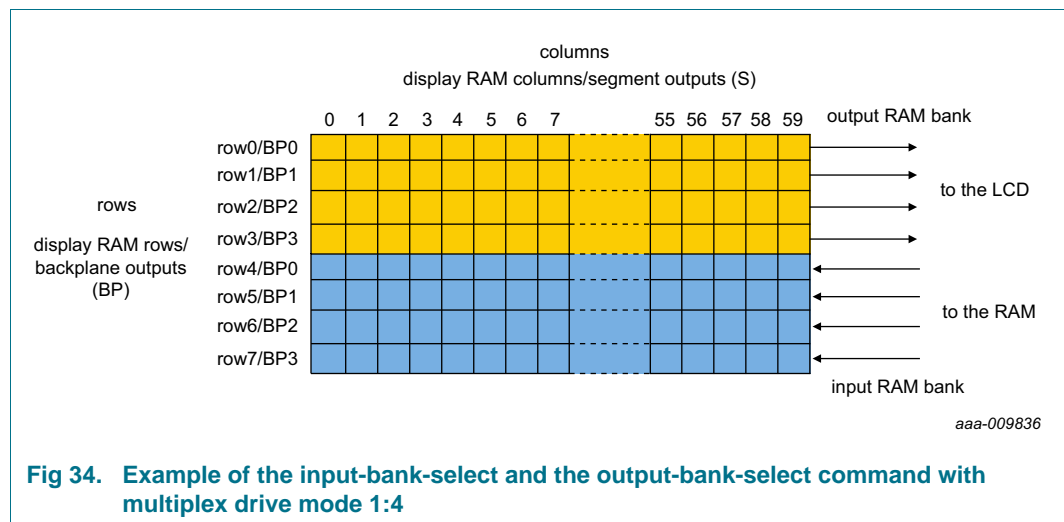

**Fig 34. Example of the input-bank-select and the output-bank-select command with multiplex drive mode 1:4**

**8.9.2.1 Input-bank-select**

The IBS bit in the input-bank-select command (see [Table 19 on page 11](#)) controls in which RAM bank the display data is loaded. The input-bank-select command works independently to the output-bank-select.

**8.9.2.2 Output-bank-select**

The OBS bit in the output-bank-select command (see [Table 20 on page 11](#)) controls from which RAM bank the display data is displayed. The output-bank-select command works independently to the input-bank-select.

## 9. I<sup>2</sup>C-bus interface characteristics

The I<sup>2</sup>C-bus is for bidirectional, two-line communication between different ICs or modules. The two lines are a Serial DATA line (SDA) and a Serial CLOCK line (SCL). Both lines must be connected to a positive supply via a pull-up resistor when connected to the output stages of a device. Data transfer may be initiated only when the bus is not busy.

### 9.1 Bit transfer

One data bit is transferred during each clock pulse. The data on the SDA line must remain stable during the HIGH period of the clock pulse as changes in the data line at this time will be interpreted as a control signal (see [Figure 35](#)).

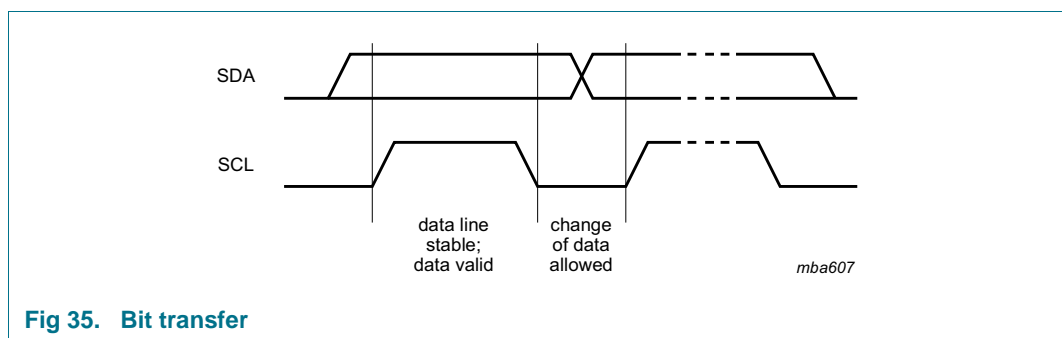

Fig 35. Bit transfer

### 9.2 START and STOP conditions

Both data and clock lines remain HIGH when the bus is not busy.

A HIGH-to-LOW change of the data line, while the clock is HIGH is defined as the START condition (S).

A LOW-to-HIGH change of the data line while the clock is HIGH is defined as the STOP condition (P).

The START and STOP conditions are shown in [Figure 36](#).

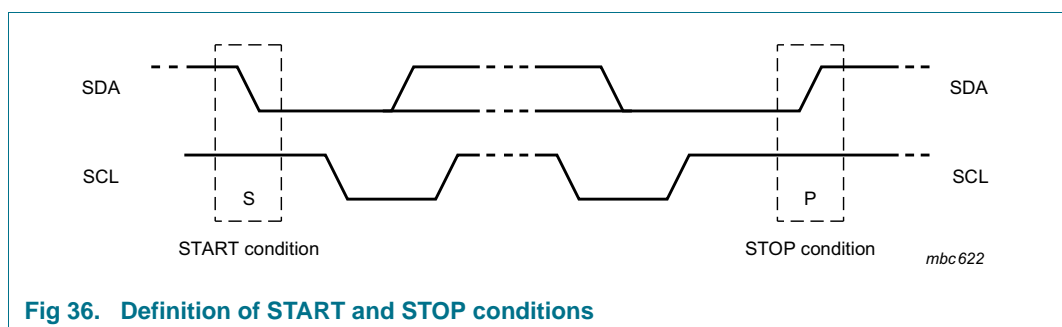

Fig 36. Definition of START and STOP conditions

### 9.3 System configuration

A device generating a message is a transmitter; a device receiving a message is the receiver. The device that controls the message is the master; and the devices which are controlled by the master are the slaves. The system configuration is shown in [Figure 37](#).

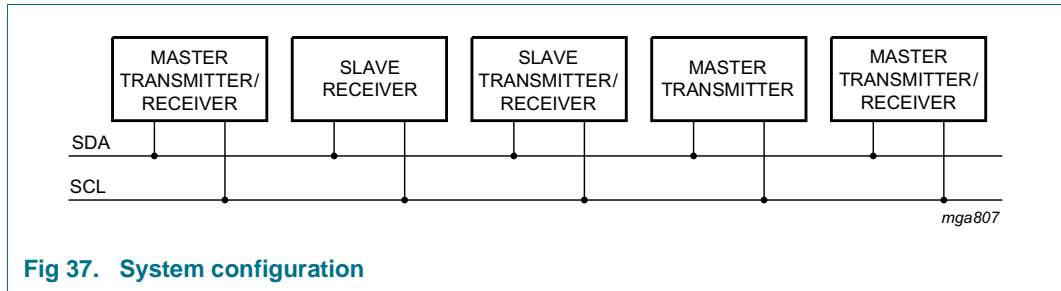

Fig 37. System configuration

### 9.4 Acknowledge

The number of data bytes transferred between the START and STOP conditions from transmitter to receiver is unlimited. Each byte of eight bits is followed by an acknowledge cycle.

- A slave receiver which is addressed must generate an acknowledge after the reception of each byte.
- Also a master receiver must generate an acknowledge after the reception of each byte that has been clocked out of the slave transmitter.
- The device that acknowledges must pull-down the SDA line during the acknowledge clock pulse, so that the SDA line is stable LOW during the HIGH period of the acknowledge related clock pulse (set-up and hold times must be taken into consideration).
- A master receiver must signal an end of data to the transmitter by not generating an acknowledge on the last byte that has been clocked out of the slave. In this event, the transmitter must leave the data line HIGH to enable the master to generate a STOP condition.

Acknowledgement on the I<sup>2</sup>C-bus is shown in [Figure 38](#).

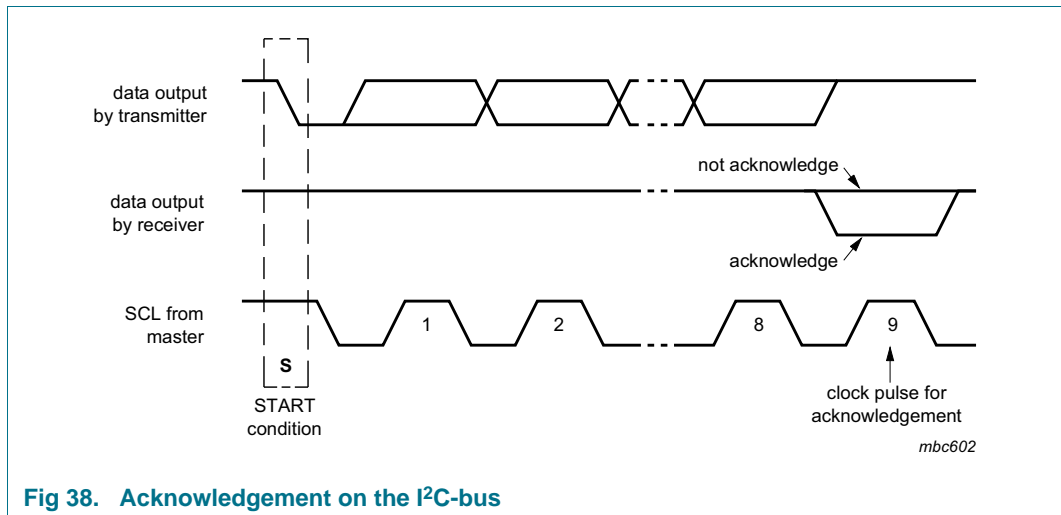

Fig 38. Acknowledgement on the I<sup>2</sup>C-bus

### 9.5 I<sup>2</sup>C-bus controller

The PCA8543 acts as an I<sup>2</sup>C-bus slave receiver. It does not initiate I<sup>2</sup>C-bus transfers or transmit data to an I<sup>2</sup>C-bus master receiver. The only data output from PCA8543 are the acknowledge signals and the temperature readout byte of the selected device.

### 9.6 Input filters

To enhance noise immunity in electrically adverse environments, RC low-pass filters are provided on the SDA and SCL lines.

### 9.7 I<sup>2</sup>C-bus slave address

Device selection depends on the I<sup>2</sup>C-bus slave address.

Four different I<sup>2</sup>C-bus slave addresses can be used to address the PCA8543 (see [Table 33](#)).

Table 33. I<sup>2</sup>C slave address

Bit	Slave address							0
	7	6	5	4	3	2	1	
	MSB							LSB
slave address	0	1	1	1	0	A1	A0	R/W

The least significant bit of the slave address byte is bit R/W. Bit 1 and bit 2 of the slave address are defined by connecting the inputs A0 and A1 to either V<sub>SS</sub> (logic 0) or V<sub>DD</sub> (logic 1). Therefore, four instances of PCA8543 can be distinguished on the same I<sup>2</sup>C-bus.

### 9.8 I<sup>2</sup>C-bus protocol

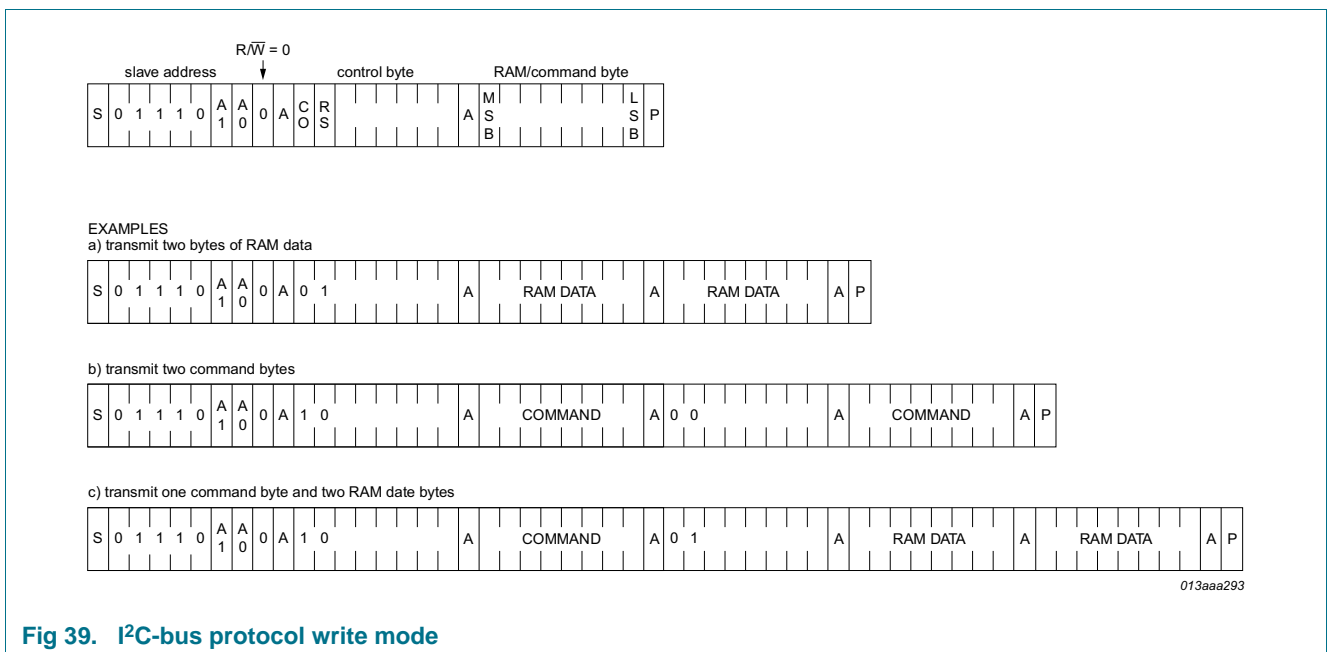

Fig 39. I<sup>2</sup>C-bus protocol write mode

The I<sup>2</sup>C-bus protocol is shown in [Figure 39](#). The sequence is initiated with a START condition (S) from the I<sup>2</sup>C-bus master which is followed by one of the four PCA8543 slave addresses available. All PCA8543's with the corresponding A1 and A0 level acknowledge in parallel to the slave address, but all PCA8543 with the alternative A1 and A0 levels ignore the whole I<sup>2</sup>C-bus transfer.

After acknowledgement, a control byte follows which defines if the next byte is RAM or command information. The control byte also defines if the next byte is a control byte or further RAM or command data.

**Table 34. Control byte description**

Bit	Symbol	Value	Description
7	CO		<b>continue bit</b>
		0	last control byte
		1	control bytes continue
6	RS		<b>register selection</b>
		0	command register
		1	data register
5 to 0	-	-	not relevant

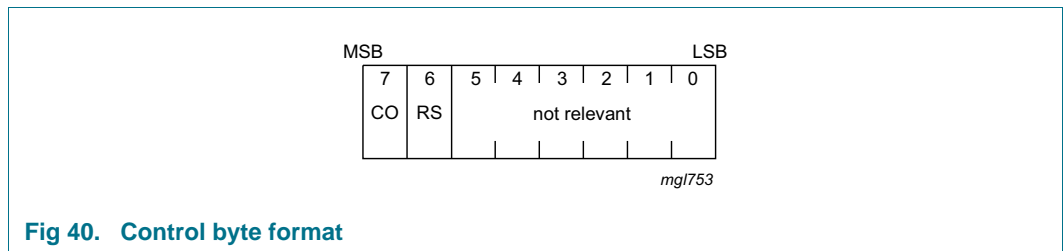

**Fig 40. Control byte format**

In this way it is possible to configure the device and then fill the display RAM with little overhead.

The display bytes are stored in the display RAM at the address specified by the data pointer.

The acknowledgement after each byte is made only by the (A0 and A1) addressed PCA8543. After the last display byte, the I<sup>2</sup>C-bus master issues a STOP condition (P). Alternatively a START may be issued to RESTART an I<sup>2</sup>C-bus access.

If a temperature readout (byte TD[7:0]) is made the R/W bit must be logic 1 and then the next data byte following is provided by the PCA8543 as shown in [Figure 41](#).

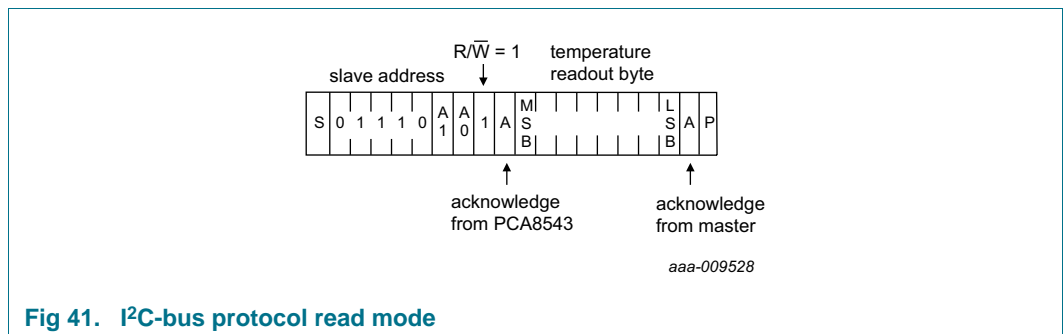

**Fig 41. I<sup>2</sup>C-bus protocol read mode**

## 10. Internal circuitry

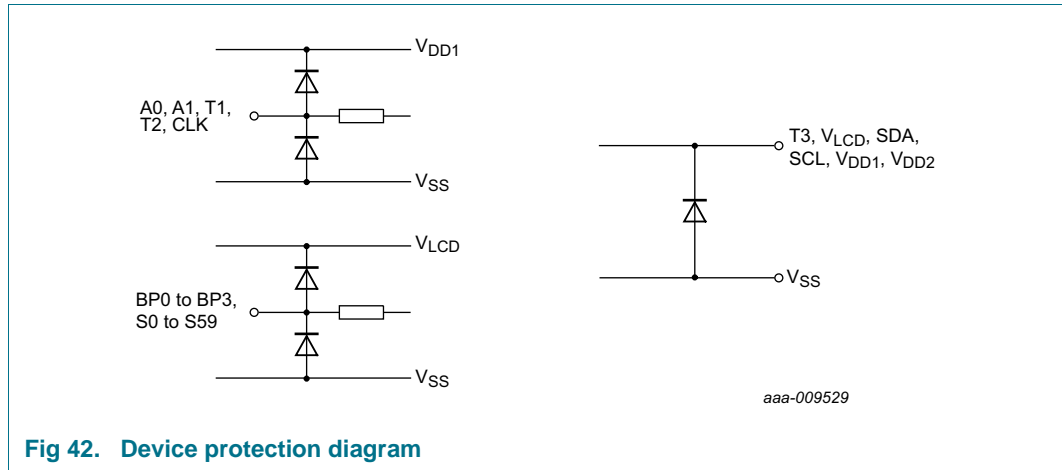

Fig 42. Device protection diagram

## 11. Safety notes

**CAUTION**



This device is sensitive to ElectroStatic Discharge (ESD). Observe precautions for handling electrostatic sensitive devices. Such precautions are described in the *ANSI/ESD S20.20*, *IEC/ST 61340-5*, *JESD625-A* or equivalent standards.

**CAUTION**



Static voltages across the liquid crystal display can build up when the LCD supply voltage ( $V_{LCD}$ ) is on while the IC supply voltage ( $V_{DD}$ ) is off, or vice versa. This may cause unwanted display artifacts. To avoid such artifacts,  $V_{LCD}$  and  $V_{DD}$  must be applied or removed together.

## 12. Limiting values

**Table 35. Limiting values**

In accordance with the Absolute Maximum Rating System (IEC 60134).

Symbol	Parameter	Conditions	Min	Max	Unit	
V <sub>DD1</sub>	supply voltage 1	analog and digital	-0.5	+6.5	V	
V <sub>DD2</sub>	supply voltage 2	charge pump	-0.5	+6.5	V	
I <sub>DD1</sub>	supply current 1	analog and digital	-50	+50	mA	
I <sub>DD2</sub>	supply current 2	charge pump	-50	+50	mA	
V <sub>LCD</sub>	LCD supply voltage		-0.5	+10	V	
I <sub>DD(LCD)</sub>	LCD supply current		-50	+50	mA	
V <sub>i</sub>	input voltage	on pins CLK, SDA, SCL, A0, A1, T1, T2, T3	-0.5	+6.5	V	
I <sub>I</sub>	input current		-10	+10	mA	
V <sub>O</sub>	output voltage	on pins S0 to S59, BP0 to BP3	-0.5	+10	V	
		on pins SDA, CLK	-0.5	+6.5	V	
I <sub>O</sub>	output current		-10	+10	mA	
I <sub>SS</sub>	ground supply current		-50	+50	mA	
P <sub>tot</sub>	total power dissipation		-	400	mW	
P/out	power dissipation per output		-	100	mW	
V <sub>ESD</sub>	electrostatic discharge voltage	HBM [1]	-	±4000	V	
		CDM [2]	-	±1500	V	
I <sub>Iu</sub>	latch-up current		[3]	100	mA	
T <sub>stg</sub>	storage temperature		[4]	-65	+150	°C
T <sub>amb</sub>	ambient temperature	operating device	-40	+105	°C	

[1] Pass level; Human Body Model (HBM), according to [Ref. 7 "JESD22-A114"](#).

[2] Pass level; Charged-Device Model (CDM), according to [Ref. 8 "JESD22-C101"](#).

[3] Pass level; latch-up testing according to [Ref. 9 "JESD78"](#) at maximum ambient temperature (T<sub>amb(max)</sub>).

[4] According to the store and transport requirements (see [Ref. 12 "UM10569"](#)) the devices have to be stored at a temperature of +8 °C to +45 °C and a humidity of 25 % to 75 %.



### 13. Static characteristics

**Table 36. Static characteristics**

$V_{DD1} = 2.5\text{ V to }5.5\text{ V}$ ;  $V_{DD2} = 2.5\text{ V to }5.5\text{ V}$ ;  $V_{SS} = 0\text{ V}$ ;  $V_{LCD} = 2.5\text{ V to }9.0\text{ V}$ ;  $T_{amb} = -40\text{ °C to }+105\text{ °C}$ ; unless otherwise specified.

Symbol	Parameter	Conditions	Min	Typ	Max	Unit
<b>Supplies</b>						
$V_{DD1}$	supply voltage 1		2.5	-	5.5	V
$V_{DD2}$	supply voltage 2	$V_{DD2} \geq V_{DD1}$	2.5	-	5.5	V
$V_{LCD}$	LCD supply voltage	$V_{LCD} \geq V_{DD2}$	[1] 2.5	-	9.0	V
$\Delta V_{LCD}$	LCD voltage variation	$V_{DD1} = V_{DD2} = 5.0\text{ V}$ ; $V_{LCD} = 6.99\text{ V}$	[2][3] -0.10	-	+0.10	V
$I_{DD(pd)}$	power-down mode supply current	on pin $V_{DD1}$	[4][5] -	1.0	3.0	$\mu\text{A}$
$I_{DD1}$	supply current 1		[5][6] -	100	200	$\mu\text{A}$
$I_{DD2}$	supply current 2	$f_{osc} = 9.6\text{ kHz}$				
		charge pump off; external $V_{LCD}$	[5][6] -	0.5	3.0	$\mu\text{A}$
		charge pump on; internal $V_{LCD}$	[5][7] -	250	550	$\mu\text{A}$
$I_{DD(LCD)}$	LCD supply current	external $V_{LCD}$	[5][8] -	125	250	$\mu\text{A}$
$I_{LCD(pd)}$	power-down LCD current	external $V_{LCD}$	[4][5] -	12	35	$\mu\text{A}$
$R_O$	output resistance	of charge pump (driving capabilities)				
		charge pump set to $2 \times V_{DD2}$ ; $I_{load} = 3\text{ mA}$ (on pin $V_{LCD}$ )	[9] 0.2	0.85	1.6	$\text{k}\Omega$
		charge pump set to $3 \times V_{DD2}$ ; $I_{load} = 2\text{ mA}$ (on pin $V_{LCD}$ )	[10] 2.0	3.2	4.5	$\text{k}\Omega$
$T_{acc}$	temperature accuracy	readout temperature error; $V_{DD1} = 5.0\text{ V}$				
		$T_{amb} = -40\text{ °C to }+105\text{ °C}$	-6	-	+6	$^{\circ}\text{C}$
		$T_{amb} = 27\text{ °C}$	-4	-	+4	$^{\circ}\text{C}$
<b>Logic</b>						
$V_I$	input voltage		$V_{SS} - 0.5$	-	$V_{DD} + 0.5$	V
$V_{IL}$	LOW-level input voltage	on pins CLK, A1, A0	-	-	$0.3V_{DD}$	V
$V_{IH}$	HIGH-level input voltage	on pins CLK, A1, A0	$0.7V_{DD}$	-	-	V
$V_O$	output voltage		-0.5	-	$V_{DD} + 0.5$	V
$V_{OH}$	HIGH-level output voltage	on pin CLK	$0.8V_{DD}$	-	-	V
$V_{OL}$	LOW-level output voltage	on pin CLK	-	-	$0.2V_{DD}$	V
$I_{OH}$	HIGH-level output current	output source current; $V_{OH} = 4.6\text{ V}$ ; $V_{DD} = 5\text{ V}$ ; on pin CLK	1	-	-	mA
$I_{OL}$	LOW-level output current	output sink current; $V_{OL} = 0.4\text{ V}$ ; $V_{DD} = 5\text{ V}$ ; on pin CLK	1	-	-	mA
$V_{POR}$	power-on reset voltage		[11] -	-	1.6	V
$I_L$	leakage current	$V_i = V_{DD}$ or $V_{SS}$ ; on pins CLK, A1, A0, T1, T2, T3	[12] -	0	-	$\mu\text{A}$

**Table 36. Static characteristics ...continued**

$V_{DD1} = 2.5\text{ V to }5.5\text{ V}$ ;  $V_{DD2} = 2.5\text{ V to }5.5\text{ V}$ ;  $V_{SS} = 0\text{ V}$ ;  $V_{LCD} = 2.5\text{ V to }9.0\text{ V}$ ;  $T_{amb} = -40\text{ }^{\circ}\text{C to }+105\text{ }^{\circ}\text{C}$ ; unless otherwise specified.

Symbol	Parameter	Conditions	Min	Typ	Max	Unit
<b>I<sup>2</sup>C-bus; pins SDA and SCL [13]</b>						
$V_I$	input voltage		$V_{SS} - 0.5$	-	5.5	V
$V_{IL}$	LOW-level input voltage	pins SCL, SDA	-	-	$0.3V_{DD}$	V
$V_{IH}$	HIGH-level input voltage	pins SCL, SDA	$0.7V_{DD}$	-	-	V
$V_O$	output voltage	pins SCL, SDA	-0.5	-	5.5	V
$I_{OL}$	LOW-level output current	$V_{OL} = 0.4\text{ V}$ ; $V_{DD} = 5\text{ V}$ ; on pin SDA	3	-	-	mA
$I_L$	leakage current	$V_I = V_{DD}$ or $V_{SS}$ [12]	-	0	-	$\mu\text{A}$
<b>LCD outputs</b>						
$\Delta V_O$	output voltage variation	on pins BP0 to BP3 [14]	-15	-	+15	mV
		on pins S0 to S59 [15]	-15	-	+15	mV
$R_O$	output resistance	$V_{LCD} = 7\text{ V}$ ; on pins BP0 to BP3 [16]	0.3	0.8	1.5	$\text{k}\Omega$
		$V_{LCD} = 7\text{ V}$ ; on pins S0 to S59 [16]	0.6	1.5	3	$\text{k}\Omega$

- [1] When supplying external  $V_{LCD}$  it must be  $V_{LCD} \geq V_{DD2}$ . Also when using the internal charge pump to generate a certain  $V_{LCD}$ ,  $VPR[7:0]$  must be set to a value that the voltage is higher than  $V_{DD2}$  (see [Section 8.4.3 on page 28](#)).
- [2] Calibrated at testing stage.  $V_{LCD}$  temperature compensation is disabled.
- [3] According to [Equation 6 on page 28](#):  $V_{LCD} = 133 \times 0.03 + 3 = 6.99\text{ V}$ .
- [4] Display is disabled; I<sup>2</sup>C-bus inactive; temperature measurement disabled.
- [5] The typical value is defined at  $V_{DD1} = V_{DD2} = 5.0\text{ V}$ ,  $V_{LCD} = 7.0\text{ V}$  and  $30\text{ }^{\circ}\text{C}$ .
- [6] Temperature measurement enabled; 1:4 multiplex drive mode; 1/4 bias; display enabled; LCD outputs are open circuit; RAM is all written with logic 1; inputs at  $V_{SS}$  or  $V_{DD}$ ; internal clock with the default prescale factor; I<sup>2</sup>C-bus inactive.
- [7]  $V_{DD2} = 5.0\text{ V}$ ; charge pump set to  $2 \times V_{DD2}$ ;  $VPR[7:0]$  set for  $V_{LCD} = 7.0\text{ V}$ ; 1:4 multiplex drive mode; 1/4 bias; temperature measurement enabled; display enabled; LCD outputs are open circuit; RAM is all written with logic 1; inputs at  $V_{SS}$  or  $V_{DD}$ ; external clock with 50 % duty factor; I<sup>2</sup>C-bus inactive.
- [8] External supplied  $V_{LCD} = 7.0\text{ V}$ ; 1:4 multiplex drive mode; 1/4 bias; temperature measurement enabled; display enabled; LCD outputs are open circuit; RAM is all written with logic 1; inputs at  $V_{SS}$  or  $V_{DD}$ ; external clock with 50 % duty factor; I<sup>2</sup>C-bus inactive.
- [9]  $V_{DD2} = 5.0\text{ V}$ ; charge pump set to  $2 \times V_{DD2}$ ;  $VPR[7:0]$  set for  $V_{LCD} = 9.0\text{ V}$ ; display disabled; CPF (see [Table 23 on page 12](#)) set logic 0.
- [10]  $V_{DD2} = 4.0\text{ V}$ ; charge pump set to  $3 \times V_{DD2}$ ;  $VPR[7:0]$  set for  $V_{LCD} = 9.0\text{ V}$ ; display disabled; CPF (see [Table 23 on page 12](#)) set logic 0.
- [11] If  $V_{DD1} > V_{POR}$  then no reset occurs.
- [12] In case of an ESD event, the value may increase slightly.
- [13] The I<sup>2</sup>C-bus interface of PCA8543 is 5 V tolerant.
- [14] Variation between any 2 backplanes on a given voltage level; static measured.
- [15] Variation between any 2 segments on a given voltage level; static measured.
- [16] Outputs measured one at a time.

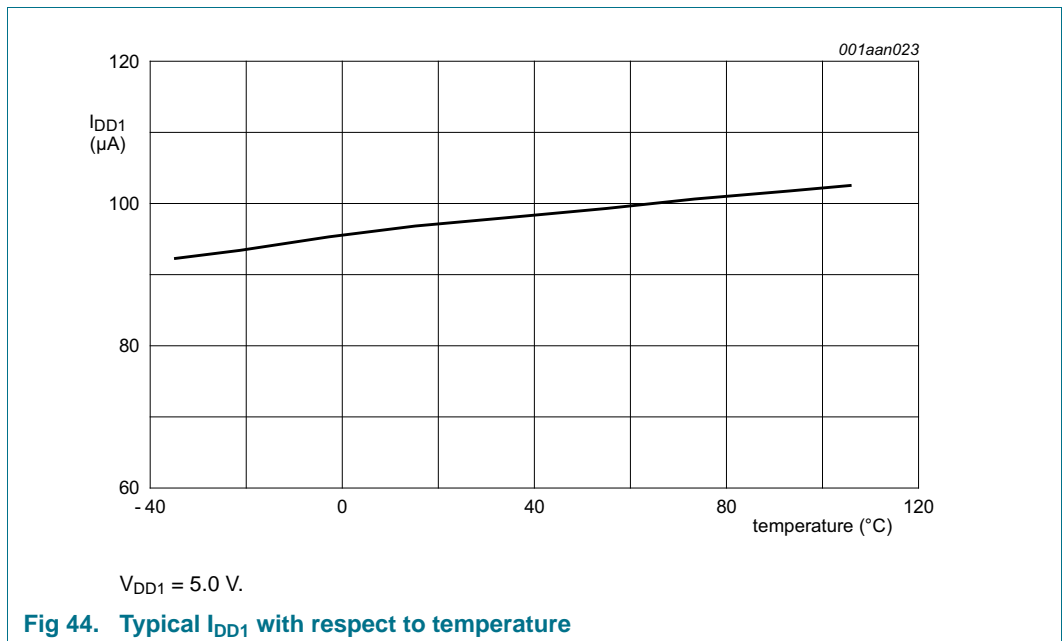
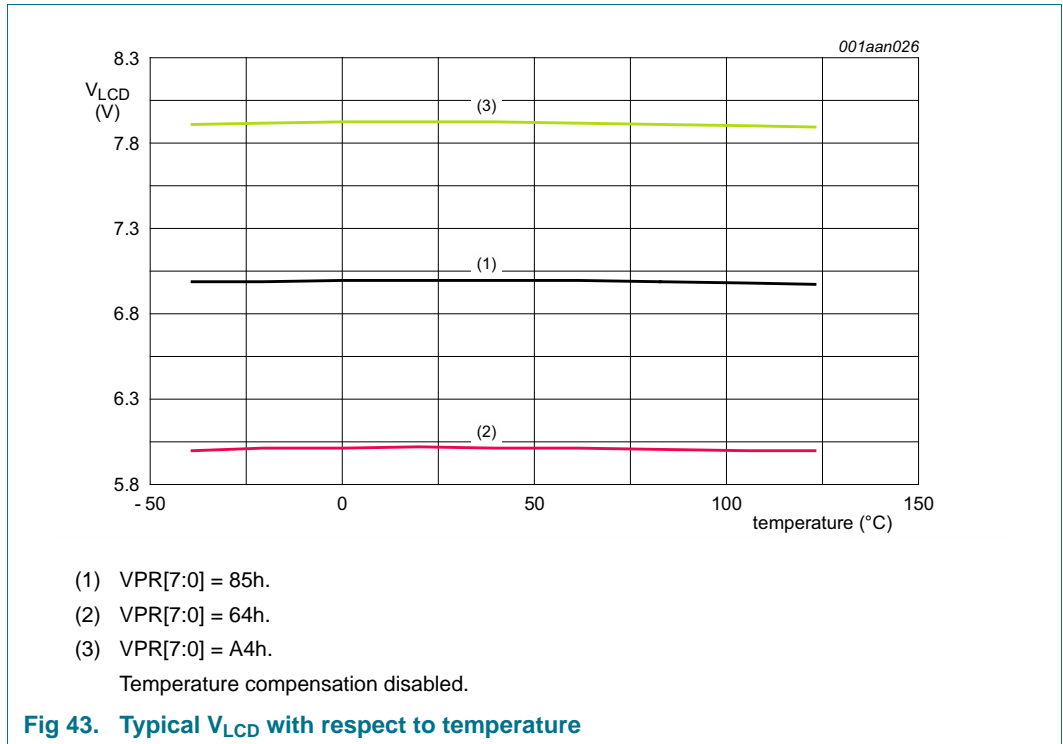

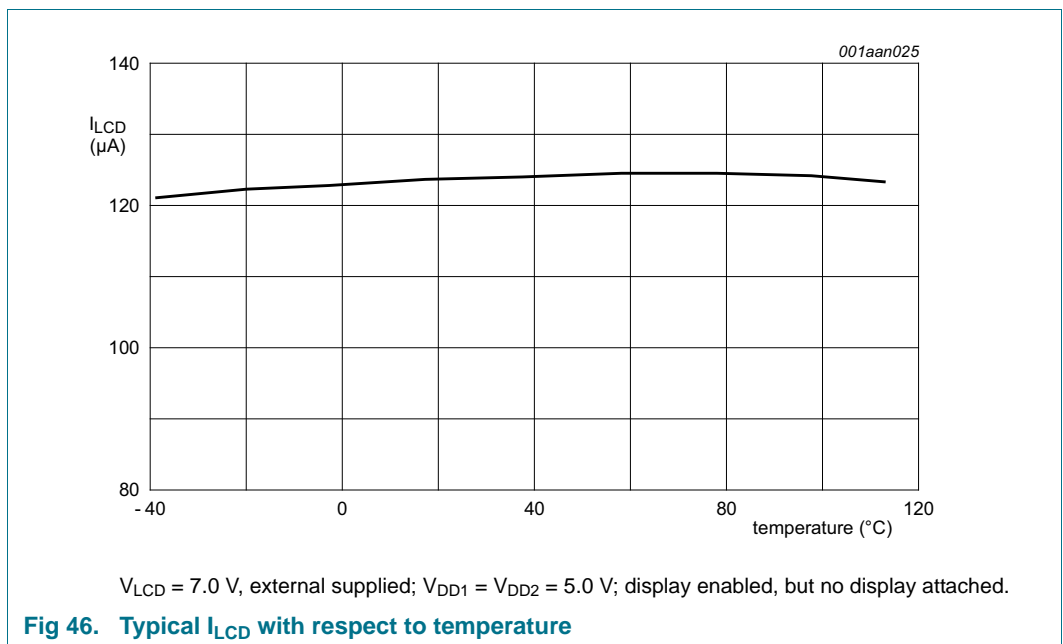
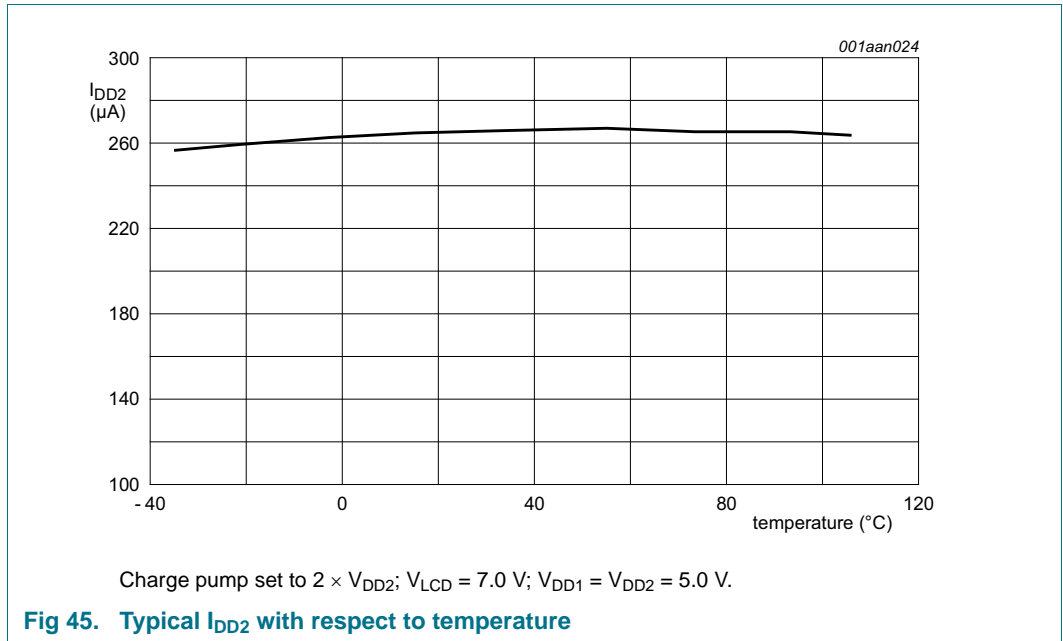

## 14. Dynamic characteristics

**Table 37. Dynamic characteristics**

$V_{DD1} = 2.5\text{ V to }5.5\text{ V}$ ;  $V_{DD2} = 2.5\text{ V to }5.5\text{ V}$ ;  $V_{SS} = 0\text{ V}$ ;  $V_{LCD} = 2.5\text{ V to }9.0\text{ V}$ ;  $T_{amb} = -40\text{ }^{\circ}\text{C to }+105\text{ }^{\circ}\text{C}$ ; unless otherwise specified.

Symbol	Parameter	Conditions	Min	Typ	Max	Unit
$f_{osc}$	oscillator frequency	on pin CLK; see <a href="#">Table 18 on page 10</a> <sup>[1][2]</sup>	8160	9600	11040	Hz
$f_{clk(ext)}$	external clock frequency		450	-	14500	Hz
$t_{clk(H)}$	HIGH-level clock time	external clock source used	33	-	-	$\mu\text{s}$
$t_{clk(L)}$	LOW-level clock time		33	-	-	$\mu\text{s}$
<b>Timing characteristics: I<sup>2</sup>C-bus<sup>[3]</sup></b>						
$f_{SCL}$	SCL frequency		-	-	400	kHz
$t_{BUF}$	bus free time between a STOP and START condition		1.3	-	-	$\mu\text{s}$
$t_{HD;STA}$	hold time (repeated) START condition		0.6	-	-	$\mu\text{s}$
$t_{SU;STA}$	set-up time for a repeated START condition		0.6	-	-	$\mu\text{s}$
$t_{VD;DAT}$	data valid time	<sup>[4]</sup>	-	-	0.9	$\mu\text{s}$
$t_{VD;ACK}$	data valid acknowledge time	<sup>[5]</sup>	-	-	0.9	$\mu\text{s}$
$t_{LOW}$	LOW period of the SCL clock		1.3	-	-	$\mu\text{s}$
$t_{HIGH}$	HIGH period of the SCL clock		0.6	-	-	$\mu\text{s}$
$t_f$	fall time	of both SDA and SCL signals	-	-	0.3	$\mu\text{s}$
$t_r$	rise time	of both SDA and SCL signals	-	-	0.3	$\mu\text{s}$
$C_b$	capacitive load for each bus line		-	-	400	pF
$t_{SU;DAT}$	data set-up time		100	-	-	ns
$t_{HD;DAT}$	data hold time		0	-	-	ns
$t_{SU;STO}$	set-up time for STOP condition		0.6	-	-	$\mu\text{s}$
$t_{w(spikes)}$	spike pulse width		-	-	50	ns

[1] Internal calibration made with OTP so that the maximum variation is  $\pm 15\%$  over whole temperature and voltage range. The typical  $f_{osc}$  generates a typical frame frequency of 200 Hz when the default frequency division factor is used (see [Section 8.5.3 on page 36](#)).

[2] The typical value is defined at  $V_{DD1} = V_{DD2} = 5.0\text{ V}$  and  $30\text{ }^{\circ}\text{C}$ .

[3] All timing values are valid within the operating supply voltage and ambient temperature range and are referenced to  $V_{IL}$  and  $V_{IH}$  with an input voltage swing of  $V_{SS}$  to  $V_{DD}$ .

[4]  $t_{VD;DAT}$  = minimum time for valid SDA output following SCL LOW.

[5]  $t_{VD;ACK}$  = time for acknowledgement signal from SCL LOW to SDA output LOW.

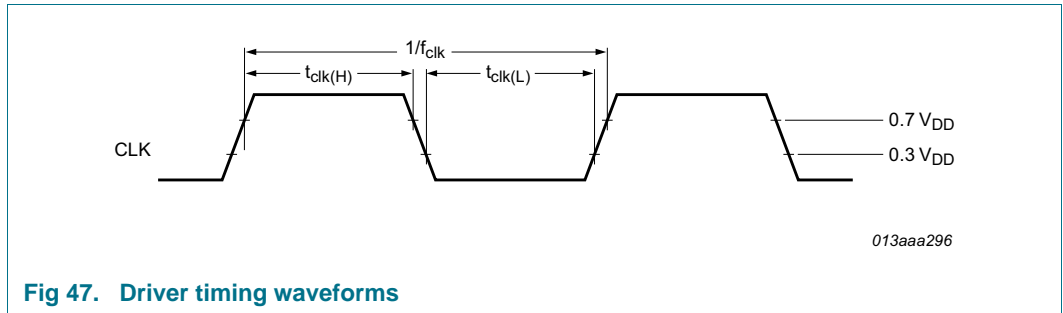

Fig 47. Driver timing waveforms

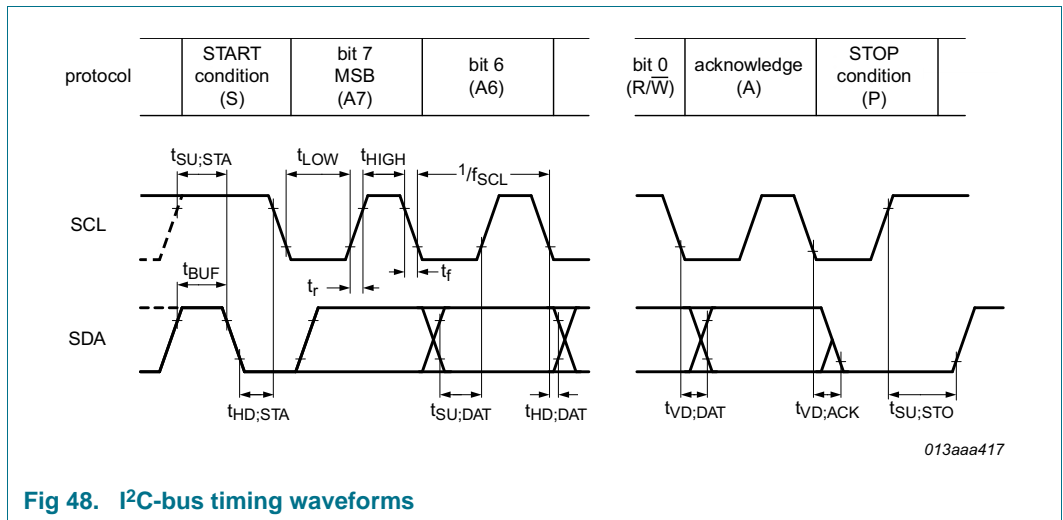

Fig 48. I<sup>2</sup>C-bus timing waveforms

## 15. Test information

### 15.1 Quality information

This product has been qualified in accordance with the Automotive Electronics Council (AEC) standard Q100 - *Failure mechanism based stress test qualification for integrated circuits*, and is suitable for use in automotive applications.

16. Package outline

LQFP80: plastic low profile quad flat package; 80 leads; body 12 x 12 x 1.4 mm

SOT315-1

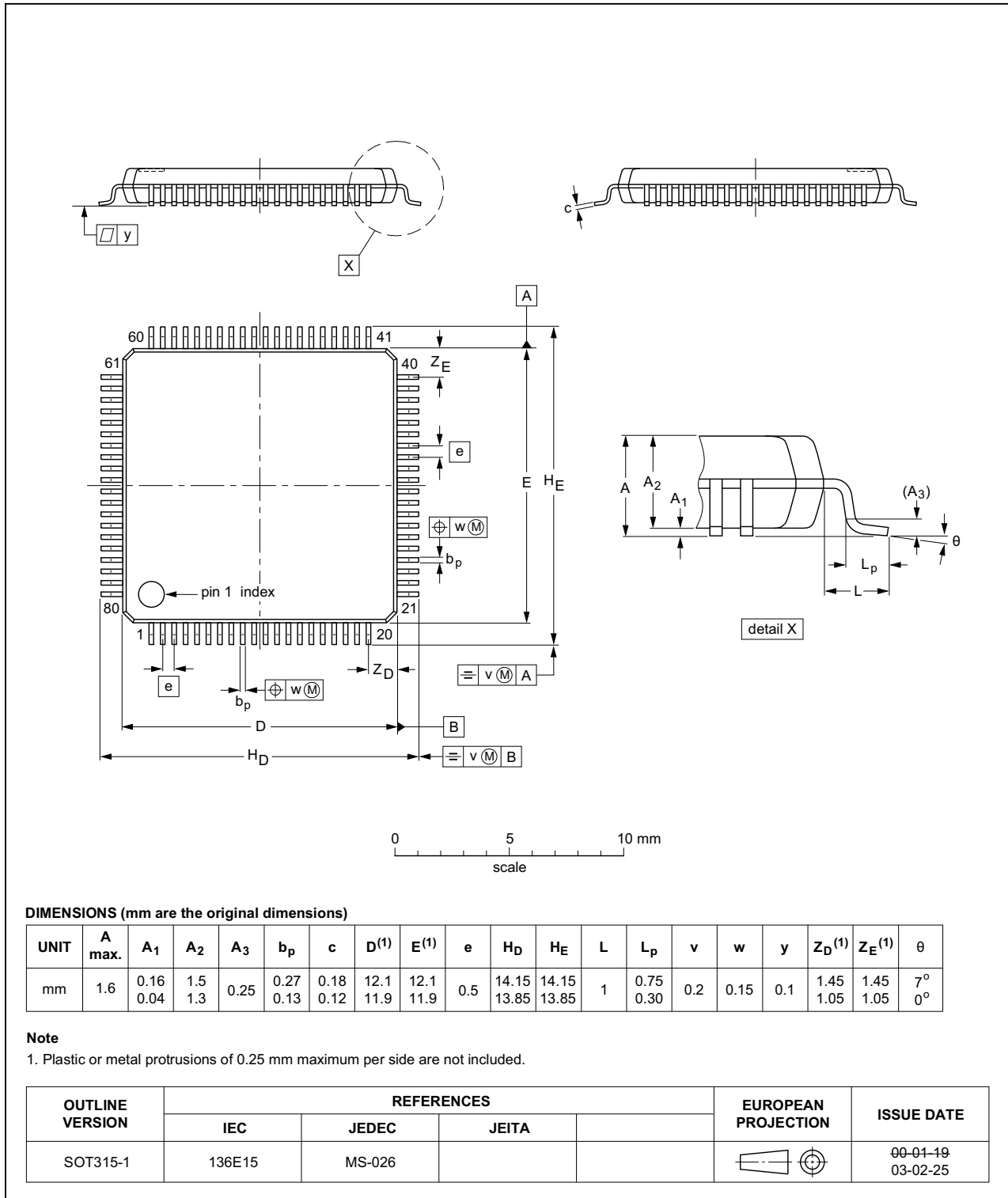

Fig 49. Package outline SOT315-1 (LQFP80) of PCA8543AHL

## 17. Soldering of SMD packages

This text provides a very brief insight into a complex technology. A more in-depth account of soldering ICs can be found in Application Note *AN10365 "Surface mount reflow soldering description"*.

### 17.1 Introduction to soldering

Soldering is one of the most common methods through which packages are attached to Printed Circuit Boards (PCBs), to form electrical circuits. The soldered joint provides both the mechanical and the electrical connection. There is no single soldering method that is ideal for all IC packages. Wave soldering is often preferred when through-hole and Surface Mount Devices (SMDs) are mixed on one printed wiring board; however, it is not suitable for fine pitch SMDs. Reflow soldering is ideal for the small pitches and high densities that come with increased miniaturization.

### 17.2 Wave and reflow soldering

Wave soldering is a joining technology in which the joints are made by solder coming from a standing wave of liquid solder. The wave soldering process is suitable for the following:

- Through-hole components
- Leaded or leadless SMDs, which are glued to the surface of the printed circuit board

Not all SMDs can be wave soldered. Packages with solder balls, and some leadless packages which have solder lands underneath the body, cannot be wave soldered. Also, leaded SMDs with leads having a pitch smaller than ~0.6 mm cannot be wave soldered, due to an increased probability of bridging.

The reflow soldering process involves applying solder paste to a board, followed by component placement and exposure to a temperature profile. Leaded packages, packages with solder balls, and leadless packages are all reflow solderable.

Key characteristics in both wave and reflow soldering are:

- Board specifications, including the board finish, solder masks and vias
- Package footprints, including solder thieves and orientation
- The moisture sensitivity level of the packages
- Package placement
- Inspection and repair
- Lead-free soldering versus SnPb soldering

### 17.3 Wave soldering

Key characteristics in wave soldering are:

- Process issues, such as application of adhesive and flux, clinching of leads, board transport, the solder wave parameters, and the time during which components are exposed to the wave
- Solder bath specifications, including temperature and impurities



### 17.4 Reflow soldering

Key characteristics in reflow soldering are:

- Lead-free versus SnPb soldering; note that a lead-free reflow process usually leads to higher minimum peak temperatures (see [Figure 50](#)) than a SnPb process, thus reducing the process window
- Solder paste printing issues including smearing, release, and adjusting the process window for a mix of large and small components on one board
- Reflow temperature profile; this profile includes preheat, reflow (in which the board is heated to the peak temperature) and cooling down. It is imperative that the peak temperature is high enough for the solder to make reliable solder joints (a solder paste characteristic). In addition, the peak temperature must be low enough that the packages and/or boards are not damaged. The peak temperature of the package depends on package thickness and volume and is classified in accordance with [Table 38](#) and [39](#)

**Table 38. SnPb eutectic process (from J-STD-020D)**

Package thickness (mm)	Package reflow temperature (°C)	
	Volume (mm <sup>3</sup> )	
	< 350	≥ 350
< 2.5	235	220
≥ 2.5	220	220

**Table 39. Lead-free process (from J-STD-020D)**

Package thickness (mm)	Package reflow temperature (°C)		
	Volume (mm <sup>3</sup> )		
	< 350	350 to 2000	> 2000
< 1.6	260	260	260
1.6 to 2.5	260	250	245
> 2.5	250	245	245

Moisture sensitivity precautions, as indicated on the packing, must be respected at all times.

Studies have shown that small packages reach higher temperatures during reflow soldering, see [Figure 50](#).

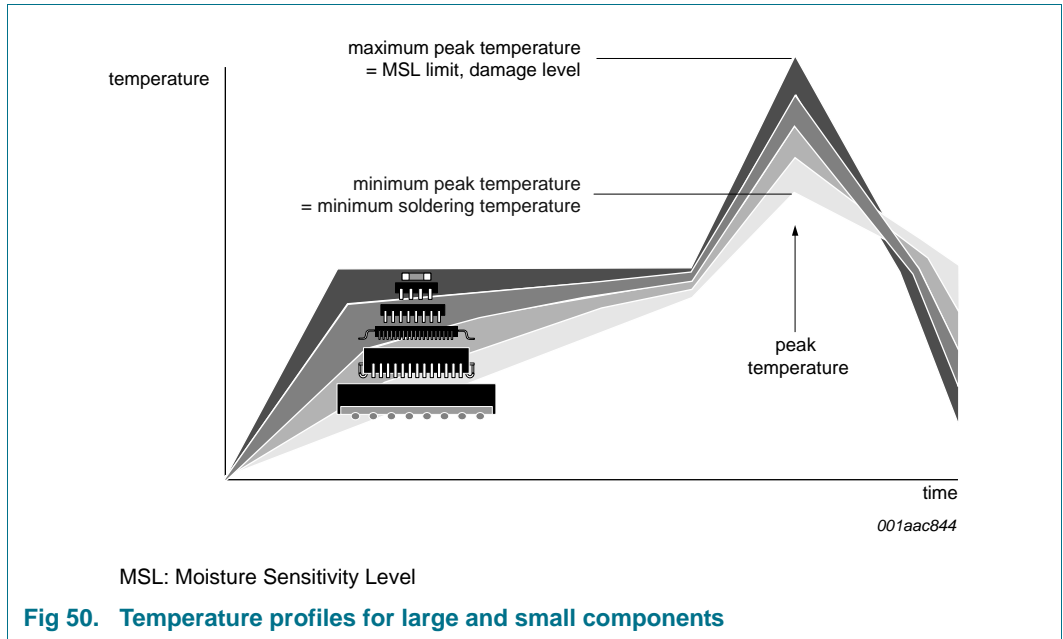

For further information on temperature profiles, refer to Application Note AN10365 “Surface mount reflow soldering description”.

## 18. Appendix

## 18.1 LCD segment driver selection

Table 40. Selection of LCD segment drivers

Type name	Number of elements at MUX							V <sub>DD</sub> (V)	V <sub>LCD</sub> (V)	f <sub>fr</sub> (Hz)	V <sub>LCD</sub> (V) charge pump	V <sub>LCD</sub> (V) temperature compensat.	T <sub>amb</sub> (°C)	Interface	Package	AEC- Q100
	1:1	1:2	1:3	1:4	1:6	1:8	1:9									
PCA8553DTT	40	80	120	160	-	-	-	1.8 to 5.5	1.8 to 5.5	32 to 256 <sup>[1]</sup>	N	N	-40 to 105	I <sup>2</sup> C / SPI	TSSOP56	Y
PCA8546ATT	-	-	-	176	-	-	-	1.8 to 5.5	2.5 to 9	60 to 300 <sup>[1]</sup>	N	N	-40 to 95	I <sup>2</sup> C	TSSOP56	Y
PCA8546BTT	-	-	-	176	-	-	-	1.8 to 5.5	2.5 to 9	60 to 300 <sup>[1]</sup>	N	N	-40 to 95	SPI	TSSOP56	Y
PCA8547AHT	44	88	-	176	-	-	-	1.8 to 5.5	2.5 to 9	60 to 300 <sup>[1]</sup>	Y	Y	-40 to 95	I <sup>2</sup> C	TQFP64	Y
PCA8547BHT	44	88	-	176	-	-	-	1.8 to 5.5	2.5 to 9	60 to 300 <sup>[1]</sup>	Y	Y	-40 to 95	SPI	TQFP64	Y
PCF85134HL	60	120	180	240	-	-	-	1.8 to 5.5	2.5 to 6.5	82	N	N	-40 to 85	I <sup>2</sup> C	LQFP80	N
PCA85134H	60	120	180	240	-	-	-	1.8 to 5.5	2.5 to 8	82	N	N	-40 to 95	I <sup>2</sup> C	LQFP80	Y
PCA8543AHL	60	120	-	240	-	-	-	2.5 to 5.5	2.5 to 9	60 to 300 <sup>[1]</sup>	Y	Y	-40 to 105	I <sup>2</sup> C	LQFP80	Y
PCF8545ATT	-	-	-	176	252	320	-	1.8 to 5.5	2.5 to 5.5	60 to 300 <sup>[1]</sup>	N	N	-40 to 85	I <sup>2</sup> C	TSSOP56	N
PCF8545BTT	-	-	-	176	252	320	-	1.8 to 5.5	2.5 to 5.5	60 to 300 <sup>[1]</sup>	N	N	-40 to 85	SPI	TSSOP56	N
PCF8536AT	-	-	-	176	252	320	-	1.8 to 5.5	2.5 to 9	60 to 300 <sup>[1]</sup>	N	N	-40 to 85	I <sup>2</sup> C	TSSOP56	N
PCF8536BT	-	-	-	176	252	320	-	1.8 to 5.5	2.5 to 9	60 to 300 <sup>[1]</sup>	N	N	-40 to 85	SPI	TSSOP56	N
PCA8536AT	-	-	-	176	252	320	-	1.8 to 5.5	2.5 to 9	60 to 300 <sup>[1]</sup>	N	N	-40 to 95	I <sup>2</sup> C	TSSOP56	Y
PCA8536BT	-	-	-	176	252	320	-	1.8 to 5.5	2.5 to 9	60 to 300 <sup>[1]</sup>	N	N	-40 to 95	SPI	TSSOP56	Y
PCF8537AH	44	88	-	176	276	352	-	1.8 to 5.5	2.5 to 9	60 to 300 <sup>[1]</sup>	Y	Y	-40 to 85	I <sup>2</sup> C	TQFP64	N
PCF8537BH	44	88	-	176	276	352	-	1.8 to 5.5	2.5 to 9	60 to 300 <sup>[1]</sup>	Y	Y	-40 to 85	SPI	TQFP64	N
PCA8537AH	44	88	-	176	276	352	-	1.8 to 5.5	2.5 to 9	60 to 300 <sup>[1]</sup>	Y	Y	-40 to 95	I <sup>2</sup> C	TQFP64	Y
PCA8537BH	44	88	-	176	276	352	-	1.8 to 5.5	2.5 to 9	60 to 300 <sup>[1]</sup>	Y	Y	-40 to 95	SPI	TQFP64	Y
PCA9620H	60	120	-	240	320	480	-	2.5 to 5.5	2.5 to 9	60 to 300 <sup>[1]</sup>	Y	Y	-40 to 105	I <sup>2</sup> C	LQFP80	Y
PCA9620U	60	120	-	240	320	480	-	2.5 to 5.5	2.5 to 9	60 to 300 <sup>[1]</sup>	Y	Y	-40 to 105	I <sup>2</sup> C	Bare die	Y
PCF8576DU	40	80	120	160	-	-	-	1.8 to 5.5	2.5 to 6.5	77	N	N	-40 to 85	I <sup>2</sup> C	Bare die	N
PCF8576EUG	40	80	120	160	-	-	-	1.8 to 5.5	2.5 to 6.5	77	N	N	-40 to 85	I <sup>2</sup> C	Bare die	N
PCA8576FUG	40	80	120	160	-	-	-	1.8 to 5.5	2.5 to 8	200	N	N	-40 to 105	I <sup>2</sup> C	Bare die	Y
PCF85133U	80	160	240	320	-	-	-	1.8 to 5.5	2.5 to 6.5	82, 110 <sup>[2]</sup>	N	N	-40 to 85	I <sup>2</sup> C	Bare die	N
PCA85133U	80	160	240	320	-	-	-	1.8 to 5.5	2.5 to 8	82, 110 <sup>[2]</sup>	N	N	-40 to 95	I <sup>2</sup> C	Bare die	Y

Table 40. Selection of LCD segment drivers ...continued

Type name	Number of elements at MUX							V <sub>DD</sub> (V)	V <sub>LCD</sub> (V)	f <sub>fr</sub> (Hz)	V <sub>LCD</sub> (V) charge pump	V <sub>LCD</sub> (V) temperature compensat.	T <sub>amb</sub> (°C)	Interface	Package	AEC- Q100
	1:1	1:2	1:3	1:4	1:6	1:8	1:9									
PCA85233UG	80	160	240	320	-	-	-	1.8 to 5.5	2.5 to 8	150, 220 <sup>[2]</sup>	N	N	-40 to 105	I <sup>2</sup> C	Bare die	Y
PCF85132U	160	320	480	640	-	-	-	1.8 to 5.5	1.8 to 8	60 to 90 <sup>[1]</sup>	N	N	-40 to 85	I <sup>2</sup> C	Bare die	N
PCA8530DUG	102	204	-	408	-	-	-	2.5 to 5.5	4 to 12	45 to 300 <sup>[1]</sup>	Y	Y	-40 to 105	I <sup>2</sup> C / SPI	Bare die	Y
PCA85132U	160	320	480	640	-	-	-	1.8 to 5.5	1.8 to 8	60 to 90 <sup>[1]</sup>	N	N	-40 to 95	I <sup>2</sup> C	Bare die	Y
PCA85232U	160	320	480	640	-	-	-	1.8 to 5.5	1.8 to 8	117 to 176 <sup>[1]</sup>	N	N	-40 to 95	I <sup>2</sup> C	Bare die	Y
PCF8538UG	102	204	-	408	612	816	918	2.5 to 5.5	4 to 12	45 to 300 <sup>[1]</sup>	Y	Y	-40 to 85	I <sup>2</sup> C / SPI	Bare die	N
PCA8538UG	102	204	-	408	612	816	918	2.5 to 5.5	4 to 12	45 to 300 <sup>[1]</sup>	Y	Y	-40 to 105	I <sup>2</sup> C / SPI	Bare die	Y

[1] Software programmable.

[2] Hardware selectable.

## 19. Abbreviations

Table 41. Abbreviations

Acronym	Description
AEC	Automotive Electronics Council
CDM	Charged-Device Model
DC	Direct Current
EPROM	Erasable Programmable Read-Only Memory
ESD	ElectroStatic Discharge
HBM	Human Body Model
I <sup>2</sup> C	Inter-Integrated Circuit bus
IC	Integrated Circuit
LCD	Liquid Crystal Display
LSB	Least Significant Bit
MSB	Most Significant Bit
MSL	Moisture Sensitivity Level
MUX	Multiplexer
OTP	One Time Programmable
PCB	Printed-Circuit Board
POR	Power-On Reset
RC	Resistance-Capacitance
RAM	Random Access Memory
RMS	Root Mean Square
SCL	Serial CLock line
SDA	Serial DAta line
SMD	Surface Mount Device

## 20. References

- [1] **AN10365** — Surface mount reflow soldering description
- [2] **AN10853** — ESD and EMC sensitivity of IC
- [3] **AN11267** — EMC and system level ESD design guidelines for LCD drivers
- [4] **IEC 60134** — Rating systems for electronic tubes and valves and analogous semiconductor devices
- [5] **IEC 61340-5** — Protection of electronic devices from electrostatic phenomena
- [6] **IPC/JEDEC J-STD-020D** — Moisture/Reflow Sensitivity Classification for Nonhermetic Solid State Surface Mount Devices
- [7] **JESD22-A114** — Electrostatic Discharge (ESD) Sensitivity Testing Human Body Model (HBM)
- [8] **JESD22-C101** — Field-Induced Charged-Device Model Test Method for Electrostatic-Discharge-Withstand Thresholds of Microelectronic Components
- [9] **JESD78** — IC Latch-Up Test

- [10] **JESD625-A** — Requirements for Handling Electrostatic-Discharge-Sensitive (ESDS) Devices
- [11] **UM10204** — I<sup>2</sup>C-bus specification and user manual
- [12] **UM10569** — Store and transport requirements

## 21. Revision history

Table 42. Revision history

Document ID	Release date	Data sheet status	Change notice	Supersedes
PCA8543 v.2	20150407	Product data sheet	-	PCA8543 v.1
Modifications:	<ul style="list-style-type: none"><li>• The format of this data sheet has been redesigned to comply with the new identity guidelines of NXP Semiconductors.</li><li>• Legal texts have been adapted to the new company name where appropriate.</li><li>• Fixed typos</li></ul>			
PCA8543 v.1	20140121	Product data sheet	-	-

## 22. Legal information

### 22.1 Data sheet status

Document status <sup>[1][2]</sup>	Product status <sup>[3]</sup>	Definition
Objective [short] data sheet	Development	This document contains data from the objective specification for product development.
Preliminary [short] data sheet	Qualification	This document contains data from the preliminary specification.
Product [short] data sheet	Production	This document contains the product specification.

[1] Please consult the most recently issued document before initiating or completing a design.

[2] The term 'short data sheet' is explained in section "Definitions".

[3] The product status of device(s) described in this document may have changed since this document was published and may differ in case of multiple devices. The latest product status information is available on the Internet at URL <http://www.nxp.com>.

### 22.2 Definitions

**Draft** — The document is a draft version only. The content is still under internal review and subject to formal approval, which may result in modifications or additions. NXP Semiconductors does not give any representations or warranties as to the accuracy or completeness of information included herein and shall have no liability for the consequences of use of such information.

**Short data sheet** — A short data sheet is an extract from a full data sheet with the same product type number(s) and title. A short data sheet is intended for quick reference only and should not be relied upon to contain detailed and full information. For detailed and full information see the relevant full data sheet, which is available on request via the local NXP Semiconductors sales office. In case of any inconsistency or conflict with the short data sheet, the full data sheet shall prevail.

**Product specification** — The information and data provided in a Product data sheet shall define the specification of the product as agreed between NXP Semiconductors and its customer, unless NXP Semiconductors and customer have explicitly agreed otherwise in writing. In no event however, shall an agreement be valid in which the NXP Semiconductors product is deemed to offer functions and qualities beyond those described in the Product data sheet.

### 22.3 Disclaimers

**Limited warranty and liability** — Information in this document is believed to be accurate and reliable. However, NXP Semiconductors does not give any representations or warranties, expressed or implied, as to the accuracy or completeness of such information and shall have no liability for the consequences of use of such information. NXP Semiconductors takes no responsibility for the content in this document if provided by an information source outside of NXP Semiconductors.

In no event shall NXP Semiconductors be liable for any indirect, incidental, punitive, special or consequential damages (including - without limitation - lost profits, lost savings, business interruption, costs related to the removal or replacement of any products or rework charges) whether or not such damages are based on tort (including negligence), warranty, breach of contract or any other legal theory.

Notwithstanding any damages that customer might incur for any reason whatsoever, NXP Semiconductors' aggregate and cumulative liability towards customer for the products described herein shall be limited in accordance with the *Terms and conditions of commercial sale* of NXP Semiconductors.

**Right to make changes** — NXP Semiconductors reserves the right to make changes to information published in this document, including without limitation specifications and product descriptions, at any time and without notice. This document supersedes and replaces all information supplied prior to the publication hereof.

**Suitability for use in automotive applications** — This NXP Semiconductors product has been qualified for use in automotive applications. Unless otherwise agreed in writing, the product is not designed, authorized or warranted to be suitable for use in life support, life-critical or safety-critical systems or equipment, nor in applications where failure or malfunction of an NXP Semiconductors product can reasonably be expected to result in personal injury, death or severe property or environmental damage. NXP Semiconductors and its suppliers accept no liability for inclusion and/or use of NXP Semiconductors products in such equipment or applications and therefore such inclusion and/or use is at the customer's own risk.

**Applications** — Applications that are described herein for any of these products are for illustrative purposes only. NXP Semiconductors makes no representation or warranty that such applications will be suitable for the specified use without further testing or modification.

Customers are responsible for the design and operation of their applications and products using NXP Semiconductors products, and NXP Semiconductors accepts no liability for any assistance with applications or customer product design. It is customer's sole responsibility to determine whether the NXP Semiconductors product is suitable and fit for the customer's applications and products planned, as well as for the planned application and use of customer's third party customer(s). Customers should provide appropriate design and operating safeguards to minimize the risks associated with their applications and products.

NXP Semiconductors does not accept any liability related to any default, damage, costs or problem which is based on any weakness or default in the customer's applications or products, or the application or use by customer's third party customer(s). Customer is responsible for doing all necessary testing for the customer's applications and products using NXP Semiconductors products in order to avoid a default of the applications and the products or of the application or use by customer's third party customer(s). NXP does not accept any liability in this respect.

**Limiting values** — Stress above one or more limiting values (as defined in the Absolute Maximum Ratings System of IEC 60134) will cause permanent damage to the device. Limiting values are stress ratings only and (proper) operation of the device at these or any other conditions above those given in the Recommended operating conditions section (if present) or the Characteristics sections of this document is not warranted. Constant or repeated exposure to limiting values will permanently and irreversibly affect the quality and reliability of the device.

**Terms and conditions of commercial sale** — NXP Semiconductors products are sold subject to the general terms and conditions of commercial sale, as published at <http://www.nxp.com/profile/terms>, unless otherwise agreed in a valid written individual agreement. In case an individual agreement is concluded only the terms and conditions of the respective agreement shall apply. NXP Semiconductors hereby expressly objects to applying the customer's general terms and conditions with regard to the purchase of NXP Semiconductors products by customer.



**No offer to sell or license** — Nothing in this document may be interpreted or construed as an offer to sell products that is open for acceptance or the grant, conveyance or implication of any license under any copyrights, patents or other industrial or intellectual property rights.

**Export control** — This document as well as the item(s) described herein may be subject to export control regulations. Export might require a prior authorization from competent authorities.

**Translations** — A non-English (translated) version of a document is for reference only. The English version shall prevail in case of any discrepancy between the translated and English versions.

## 22.4 Trademarks

Notice: All referenced brands, product names, service names and trademarks are the property of their respective owners.

**I<sup>2</sup>C-bus** — logo is a trademark of NXP Semiconductors N.V.

## 23. Contact information

---

For more information, please visit: <http://www.nxp.com>

For sales office addresses, please send an email to: [salesaddresses@nxp.com](mailto:salesaddresses@nxp.com)

## 24. Tables

Table 1. Ordering information	2	Table 34. Control byte description	46
Table 2. Ordering options	2	Table 35. Limiting values	48
Table 3. Marking codes	2	Table 36. Static characteristics	49
Table 4. Pin description	5	Table 37. Dynamic characteristics	53
Table 5. Commands of PCA8543	6	Table 38. SnPb eutectic process (from J-STD-020D)	57
Table 6. Initialize - initialize command bit description	7	Table 39. Lead-free process (from J-STD-020D)	57
Table 7. OTP-refresh - OTP-refresh command bit description	7	Table 40. Selection of LCD segment drivers	59
Table 8. Oscillator-ctrl - oscillator control command bit description	7	Table 41. Abbreviations	61
Table 9. Charge-pump-ctrl - charge pump control command bit description	8	Table 42. Revision history	63
Table 10. Temp-msr-ctrl - temperature measurement control command bit description	8		
Table 11. Set-VPR-MSB - set VPR MSB command bit description	8		
Table 12. Set-VPR-LSB - set VPR LSB command bit description	9		
Table 13. Display-enable - display enable command bit description	9		
Table 14. Set-MUX-mode - set multiplex drive mode command bit description	9		
Table 15. Set-bias-mode - set bias mode command bit description	9		
Table 16. Load-data-pointer - load data pointer command bit description	9		
Table 17. Frame frequency - frame frequency and output clock frequency command bit description	10		
Table 18. Frame frequency values	10		
Table 19. Input-bank-select - input bank select command bit description	11		
Table 20. Output-bank-select - output bank select command bit description	11		
Table 21. Write-RAM-data - write RAM data command bit description <sup>[1]</sup>	11		
Table 22. Temp-read - temperature readout command bit description <sup>[1]</sup>	11		
Table 23. Invmode_CPF_ctrl - inversion mode and charge pump frequency prescaler command bit description	12		
Table 24. Temp-filter - digital temperature filter command bit description	12		
Table 25. Selection of possible display configurations	13		
Table 26. Reset states	15		
Table 27. LCD drive modes: summary of characteristics	22		
Table 28. Parameters of $V_{LCD}$ generation	28		
Table 29. Temperature measurement update rate	32		
Table 30. Temperature coefficients	34		
Table 31. Calculation of the temperature compensated voltage $V_T$	35		
Table 32. Mapping of output pins and corresponding output signals with respect to the multiplex driving mode	36		
Table 33. I <sup>2</sup> C slave address	45		

## 25. Figures

Fig 1.	Block diagram of PCA8543 . . . . .	3	Fig 29.	Display RAM filling order in 1:2 multiplex drive mode . . . . .	40
Fig 2.	Pin configuration for LQFP80 (PCA8543AHL) . . . . .	4	Fig 30.	Data pointer wrap around in 1:2 multiplex drive mode . . . . .	40
Fig 3.	Example of displays suitable for PCA8543 . . . . .	13	Fig 31.	Display RAM filling order in 1:4 multiplex drive mode . . . . .	41
Fig 4.	Typical system configuration when using the internal $V_{LCD}$ generation . . . . .	14	Fig 32.	Data pointer wrap around in 1:4 multiplex drive mode . . . . .	41
Fig 5.	Typical system configuration when using an external $V_{LCD}$ . . . . .	14	Fig 33.	Example of bank selection in 1:4 multiplex mode . . . . .	42
Fig 6.	Recommended start-up sequence when using the internal charge pump and the internal clock signal . . . . .	17	Fig 34.	Example of the input-bank-select and the output-bank-select command with multiplex drive mode 1:4 . . . . .	42
Fig 7.	Recommended start-up sequence when using an external supplied $V_{LCD}$ and the internal clock signal . . . . .	18	Fig 35.	Bit transfer . . . . .	43
Fig 8.	Recommended start-up sequence when using the internal charge pump and an external clock signal . . . . .	18	Fig 36.	Definition of START and STOP conditions . . . . .	43
Fig 9.	Recommended start-up sequence when using an external supplied $V_{LCD}$ and an external clock signal . . . . .	19	Fig 37.	System configuration . . . . .	44
Fig 10.	Recommended power-down sequence for minimum power-down current when using the internal charge pump and the internal clock signal . . . . .	19	Fig 38.	Acknowledgement on the I <sup>2</sup> C-bus . . . . .	44
Fig 11.	Recommended power-down sequence when using an external supplied $V_{LCD}$ and the internal clock signal . . . . .	20	Fig 39.	I <sup>2</sup> C-bus protocol write mode . . . . .	45
Fig 12.	Recommended power-down sequence when using the internal charge pump and an external clock signal . . . . .	20	Fig 40.	Control byte format . . . . .	46
Fig 13.	Recommended power-down sequence when using an external supplied $V_{LCD}$ and an external clock signal . . . . .	21	Fig 41.	I <sup>2</sup> C-bus protocol read mode . . . . .	46
Fig 14.	Electro-optical characteristic: relative transmission curve of the liquid . . . . .	23	Fig 42.	Device protection diagram . . . . .	47
Fig 15.	Static drive mode waveforms (line inversion mode) . . . . .	24	Fig 43.	Typical $V_{LCD}$ with respect to temperature . . . . .	51
Fig 16.	Waveforms for the 1:2 multiplex drive mode with $\frac{1}{2}$ bias (line inversion mode) . . . . .	25	Fig 44.	Typical $I_{DD1}$ with respect to temperature . . . . .	51
Fig 17.	Waveforms for the 1:2 multiplex drive mode with $\frac{1}{3}$ bias (line inversion mode) . . . . .	26	Fig 45.	Typical $I_{DD2}$ with respect to temperature . . . . .	52
Fig 18.	Waveforms for the 1:4 multiplex drive mode with $\frac{1}{3}$ bias (line inversion mode) . . . . .	27	Fig 46.	Typical $I_{LCD}$ with respect to temperature . . . . .	52
Fig 19.	$V_{LCD}$ generation including temperature compensation . . . . .	28	Fig 47.	Driver timing waveforms . . . . .	54
Fig 20.	$V_{LCD}$ programming of PCA8543 (assuming $VT[7:0] = 0h$ ) . . . . .	29	Fig 48.	I <sup>2</sup> C-bus timing waveforms . . . . .	54
Fig 21.	Charge pump model (used to characterize the driving strength) . . . . .	30	Fig 49.	Package outline SOT315-1 (LQFP80) of PCA8543AHL . . . . .	55
Fig 22.	Power efficiency of the charge pump . . . . .	31	Fig 50.	Temperature profiles for large and small components . . . . .	58
Fig 23.	Temperature measurement block with digital temperature filter . . . . .	32			
Fig 24.	Temperature measurement delay . . . . .	33			
Fig 25.	Example of segmented temperature coefficients . . . . .	34			
Fig 26.	Display RAM bitmap . . . . .	38			
Fig 27.	Display RAM filling order in static drive mode . . . . .	39			
Fig 28.	Discarded bits and data pointer wrap around at the end of data transmission . . . . .	39			

## 26. Contents

<b>1</b>	<b>General description</b> . . . . .	<b>1</b>	8.4.6	Charge pump frequency settings and power efficiency	30
<b>2</b>	<b>Features and benefits</b> . . . . .	<b>1</b>	8.4.7	Temperature readout	32
<b>3</b>	<b>Applications</b> . . . . .	<b>2</b>	8.4.8	Temperature compensation of $V_{LCD}$	33
<b>4</b>	<b>Ordering information</b> . . . . .	<b>2</b>	8.5	Oscillator	35
4.1	Ordering options	2	8.5.1	Internal oscillator	35
<b>5</b>	<b>Marking</b> . . . . .	<b>2</b>	8.5.2	External clock	36
<b>6</b>	<b>Block diagram</b> . . . . .	<b>3</b>	8.5.3	Timing and frame frequency	36
<b>7</b>	<b>Pinning information</b> . . . . .	<b>4</b>	8.6	Backplane outputs	36
7.1	Pinning	4	8.7	Segment outputs	37
7.2	Pin description	5	8.8	Display register	37
<b>8</b>	<b>Functional description</b> . . . . .	<b>6</b>	8.9	Display RAM	37
8.1	Commands of PCA8543	6	8.9.1	Data pointer	38
8.1.1	Command: initialize	6	8.9.1.1	RAM filling in static drive mode	39
8.1.2	Command: OTP-refresh	7	8.9.1.2	RAM filling in 1:2 multiplex drive mode	40
8.1.3	Command: oscillator-ctrl	7	8.9.1.3	RAM filling in 1:4 multiplex drive mode	41
8.1.4	Command: charge-pump-ctrl	8	8.9.2	Bank selection	41
8.1.5	Command: temp-msr-ctrl	8	8.9.2.1	Input-bank-select	42
8.1.6	Command: set-VPR-MSB and set-VPR-LSB	8	8.9.2.2	Output-bank-select	42
8.1.7	Command: display-enable	9	<b>9</b>	<b>I<sup>2</sup>C-bus interface characteristics</b>	<b>43</b>
8.1.8	Command: set-MUX-mode	9	9.1	Bit transfer	43
8.1.9	Command: set-bias-mode	9	9.2	START and STOP conditions	43
8.1.10	Command: load-data-pointer	9	9.3	System configuration	43
8.1.11	Command: frame-frequency	10	9.4	Acknowledge	44
8.1.12	Bank select commands	10	9.5	I <sup>2</sup> C-bus controller	45
8.1.12.1	Command: input-bank-select	11	9.6	Input filters	45
8.1.12.2	Command: output-bank-select	11	9.7	I <sup>2</sup> C-bus slave address	45
8.1.13	Command: write-RAM-data	11	9.8	I <sup>2</sup> C-bus protocol	45
8.1.14	Command: temp-read	11	<b>10</b>	<b>Internal circuitry</b>	<b>47</b>
8.1.15	Command: invmode_CPF_ctrl	12	<b>11</b>	<b>Safety notes</b>	<b>47</b>
8.1.16	Command: temp-filter	12	<b>12</b>	<b>Limiting values</b>	<b>48</b>
8.2	Possible display configurations	13	<b>13</b>	<b>Static characteristics</b>	<b>49</b>
8.3	Start-up and shut-down	15	<b>14</b>	<b>Dynamic characteristics</b>	<b>53</b>
8.3.1	Power-On Reset (POR)	15	<b>15</b>	<b>Test information</b>	<b>54</b>
8.3.2	Recommended start-up sequences	17	15.1	Quality information	54
8.3.3	Recommended power-down sequences	19	<b>16</b>	<b>Package outline</b>	<b>55</b>
8.4	LCD voltage	21	<b>17</b>	<b>Soldering of SMD packages</b>	<b>56</b>
8.4.1	LCD voltage selector	21	17.1	Introduction to soldering	56
8.4.1.1	Electro-optical performance	23	17.2	Wave and reflow soldering	56
8.4.2	LCD drive mode waveforms	24	17.3	Wave soldering	56
8.4.2.1	Static drive mode	24	17.4	Reflow soldering	57
8.4.2.2	1:2 Multiplex drive mode	25	<b>18</b>	<b>Appendix</b>	<b>59</b>
8.4.2.3	1:4 Multiplex drive mode	27	18.1	LCD segment driver selection	59
8.4.3	$V_{LCD}$ generation	28	<b>19</b>	<b>Abbreviations</b>	<b>61</b>
8.4.4	External $V_{LCD}$ supply	29	<b>20</b>	<b>References</b>	<b>61</b>
8.4.5	Charge pump driving capability	29			

continued >>

<b>21</b>	<b>Revision history</b> .....	<b>63</b>
<b>22</b>	<b>Legal information</b> .....	<b>64</b>
22.1	Data sheet status .....	64
22.2	Definitions .....	64
22.3	Disclaimers .....	64
22.4	Trademarks .....	65
<b>23</b>	<b>Contact information</b> .....	<b>65</b>
<b>24</b>	<b>Tables</b> .....	<b>66</b>
<b>25</b>	<b>Figures</b> .....	<b>67</b>
<b>26</b>	<b>Contents</b> .....	<b>68</b>

---

Please be aware that important notices concerning this document and the product(s) described herein, have been included in section 'Legal information'.

---

© NXP Semiconductors N.V. 2015.

All rights reserved.

For more information, please visit: <http://www.nxp.com>

For sales office addresses, please send an email to: [salesaddresses@nxp.com](mailto:salesaddresses@nxp.com)

Date of release: 7 April 2015

Document identifier: PCA8543

Компания «Life Electronics» занимается поставками электронных компонентов импортного и отечественного производства от производителей и со складов крупных дистрибьюторов Европы, Америки и Азии.

С конца 2013 года компания активно расширяет линейку поставок компонентов по направлению коаксиальный кабель, кварцевые генераторы и конденсаторы (керамические, пленочные, электролитические), за счёт заключения дистрибьюторских договоров

Мы предлагаем:

- Конкурентоспособные цены и скидки постоянным клиентам.
- Специальные условия для постоянных клиентов.
- Подбор аналогов.
- Поставку компонентов в любых объемах, удовлетворяющих вашим потребностям.
- Приемлемые сроки поставки, возможна ускоренная поставка.
- Доставку товара в любую точку России и стран СНГ.
- Комплексную поставку.
- Работу по проектам и поставку образцов.
- Формирование склада под заказчика.
- Сертификаты соответствия на поставляемую продукцию (по желанию клиента).
- Тестирование поставляемой продукции.
- Поставку компонентов, требующих военную и космическую приемку.
- Входной контроль качества.
- Наличие сертификата ISO.

В составе нашей компании организован Конструкторский отдел, призванный помогать разработчикам, и инженерам.

Конструкторский отдел помогает осуществить:

- Регистрацию проекта у производителя компонентов.
- Техническую поддержку проекта.
- Защиту от снятия компонента с производства.
- Оценку стоимости проекта по компонентам.
- Изготовление тестовой платы монтаж и пусконаладочные работы.



Тел: +7 (812) 336 43 04 (многоканальный)

Email: [org@lifeelectronics.ru](mailto:org@lifeelectronics.ru)