

LCD-Modul

4x20 - 6.45mm

INCL. CONTROLLER SSD1803

*no mounting
required*

EA DIP203B-6NLW



*EA DIP203J-6NLW:
Dimension 75 x 46 mm*

FEATURES

- * HIGH-CONTRAST LCD-SUPERTWIST DISPLAY
- * BLUE BACKGROUND WITH WHITE CHARACTERS
- * BLACK&WHITE FSTN
- * EXTREME COMPACT WITH 75mm WIDTH
- * BUILT-IN CONTROLLER SSD1803 (VERY SIMILAR TO HD44780)
- * 4- AND 8-BIT INTERFACE FOR DATABUS
- * SERIAL SPI-INTERFACE (SID, SOD, SCLK, CS)
- * POWER SUPPLY +3.3 / TYP. 4mA (w./o. B./L.)
- * OPERATING TEMP. RANGE -20..+70°C
- * AUTOMATIC TEMPERATURE COMPENSATION BUILT-IN
- * LED-BACKLIGHT WHITE, max. 75mA@+25°C
- * 16 ICONS (BATTERY, ARROWS ETC.) AT THE TOP EDGE
- * NO MONTING IS REQUIRED: JUST SOLDER INTO PCB
- * SINGLE ROW SOCKET AVAILABLE: EA B254-12 (1 PC.)
- * 128x64 GRAPHIC WITH SAME DIMENSION AND SAME PINOUT: EA DIP128

ORDERING INFORMATION

LCD-MODULE 4x20 - 6.45mm WITH LED-B./L. BLUE
 FSTN BLACK ON WHITE
 SOCKET 4.5mm HEIGHT, 12 POSITIONS (1 PC.)

EA DIP203B-6NLW
EA DIP203J-6NLW
EA B254-12

PINOUT

4-/8-Bit Mode (Factory Set)			
Pin	Symbo	Function	
1	VSS	Power Supply 0V (GND)	
2	VDD	Power Supply +5V	
3	VCI	Contrast Adjustment	
4	RES	L: Reset	
5	RS	H=Data; L=Command	
6	R/W	H=Read, L=Write	
7	E	Enable	
8		not connected	
9		not connected	
10		not connected	
11		not connected	
12		not connected	

Pin	Symbo	Function	
13		not connected	
14	VSS	Power Supply 0V (GND)	
15	D0	Display Data, LSB	
16	D1	Display Data D1	
17	D2	Display Data D2	
18	D3	Display Data D3	
19	D4 (D0)	Display Data D4	
20	D5 (D1)	Display Data D5	
21	D6 (D2)	Display Data D6	
22	D7 (D3)	Display Data, MSB	
23	A	LED-B/L + (ext. Resistor requ)	
24	C	LED-B/L -	

SPI Mode (Solder link "SPI" closed)			
Pin	Symbo	Function	
1	VSS	Power Supply 0V (GND)	
2	VDD	Power Supply +5V	
3	VCI	Contrast Adjustment	
4	RES	L: Reset	
5	CS	Chip Select	
6	SID	Data In	
7	SCLK	Shift Clock	
8		not connected	
9		not connected	
10		not connected	
11		not connected	
12		not connected	

Pin	Symbo	Function	
13		not connected	
14	VSS	Power Supply 0V (GND)	
15	SOD	Data Out	
16		not connected	
17		not connected	
18		not connected	
19		not connected	
20		not connected	
21		not connected	
22		not connected	
23	A	LED-B/L + (ext. Resistor requ)	
24	C	LED-B/L -	

BACKLIGHT

Using the LED backlight requires an current source or external current-limiting resistor. Forward voltage for white LED backlight is 3.0~3.6V. Please take care of derating for $T_a > +25^\circ\text{C}$

Attention: Do never drive backlight directly to 5V; this may damage backlight immediately !

The blue display cannot be read without backlight. For direct sunlight we suggest to use the J-type.

TABLE OF COMMAND (SSD1803)

Instruction	C ode												Description	Execute Time (270kHz)			
	RE Bit	RS	R/W	DB 7	DB 6	DB 5	DB 4	DB 3	DB 2	DB 1	DB 0						
Clear Display	*	0	0	0	0	0	0	0	0	0	0	1		Clears all display and returns the cursor to the home position (Address 0).	1.53ms		
Cursor At Home	0	0	0	0	0	0	0	0	0	0	1	*		Returns the Cursor to the home position (Address 0). Also returns the display being shifted to the original position. DD RAM contents remain unchanged.	1.53ms		
Power Down Mode	1	0	0	0	0	0	0	0	0	1	PD			Set Power down mode bit. PD=0: power down mode disable PD=1: power down mode enable	39µs		
Entry Mode Set	0	0	0	0	0	0	0	0	1	I/D	S			Cursor moving direction (I/D=0: dec; I/D=1: inc) shift enable bit (S=0: disable; S=1: enable shift)	39µs		
	0	0	0	0	0	0	0	0	1	1	BID			Segment bidirectional function (BID=0: Seg1->Seg60; BID=1: Seg60->Seg1)	39µs		
Display On/Off Control	0	0	0	0	0	0	0	1	D	C	B			D=0: display off; D=1: display on C=0: cursor off; C=1: cursor on B=0: blink off; B=1: blink on	39µs		
extended Function Set	1	0	0	0	0	0	0	1	FW	BW	NW			FW=0: 5-dot font width; FW=1: 6-dot font width BW=0: normal cursor; BW=1: inverting cursor NW=0: 1- or 2-line (see N); NW=1: 4-line display	39µs		
Cursor / Display Shift	0	0	0	0	0	0	1	S/C	R/L	*	*			Moves the Cursor or shifts the display S/C=0: cursor Shift; S/C=1: display shift R/L=0: shift to left; R/L=1: shift to right	39µs		
Scroll Enable	1	0	0	0	0	0	1	H4	H3	H2	H1			Determine the line for horizontal scroll	39µs		
Function Set	0	0	0	0	0	1	DL	N	RE	DH	REV			sets interface data length (DL=0:4-bit; DL=1:8-bit) number of display lines (N=0: 1-line; N=1: 2-line) extension register (RE= 0/1) scroll/shift (DH=0: dot scroll; DH=1: display shift) reverse bit (REV=0:normal; REV=1:inverse display)	39µs		
	1	0	0	0	0	1	DL	N	RE	BE	LP			CG-/SEG-RAM blink (BE=0: disable; BE=1: enable) LP=0: normal mode; LP=1: low power mode	39µs		
CG RAM Address Set	0	0	0	0	1	AC								Sets the CG RAM address. CG RAM data is sent and received after this setting.	39µs		
SEG RAM Address Set	1	0	0	0	1	*	*	AC								Sets the SEG RAM address. SEG RAM data is sent and received after this setting.	39µs
DD RAM Address Set	0	0	0	1	AC								Sets the DD RAM address. DD RAM data is sent and received after this setting.	39µs			
Set Scroll Quantity	1	0	0	1	*	SQ								Sets the quantity of horizontal dot scroll (DH=0)	39µs		
Busy Flag / Address Read	*	0	1	BF	AC								Reads Busy flag (BF) indicating internal operation is being performed and reads address counter contents.	-			
Write Data	*	1	0	Write Data								Writes data into internal RAM (DD RAM / CG RAM / SEGRAM)	43µs				
Read Data	*	1	1	Read Data								Reads data from internal RAM (DD RAM / CG RAM / SEGRAM)	43µs				

SERIAL MODE SPI

Factory set for interface is parallel with 4 bit or 8 bit data bus. Alternative module can be programmed with serial data stream. For that solder link **SPI** has to be closed. Hardware specification for serial operation mode is written down in user manual for SSD1803: http://www.lcd-module.de/fileadmin/eng/pdf/zubehoer/SSD1803_0.20.pdf. Software for initialisation and programming keeps the same.

Example of initialisation, 8 bit mode													
Command	RE Bit	RS	R/W	DB7	DB6	DB5	DB4	DB3	DB2	DB1	DB0	Hex	Note
Function Set	0	0	0	0	0	1	1	0	0	0	0	\$30	8 bit data length, extension bit RE=0
Entry Mode Set	0	0	0	0	0	0	0	0	1	1	0	\$06	Cursor Auto-Increment
Function Set	0	0	0	0	0	1	1	0	1	1	0	\$36	8 bit data length, RE =1, blink enable BE =1
ext. Function Set	1	0	0	0	0	0	0	1	0	0	1	\$09	4 line mode
Set SEGRAM adr	1	0	0	0	1	0	0	0	0	0	0	\$40	icon RAM address: \$00
16 x Write Data	1	1	0	0	0	0	0	0	0	0	0	\$00	to clear all icons: write 16x \$00
Function Set	1	0	0	0	0	1	1	0	0	0	0	\$30	8 bit data length, bit RE =0
Display ON/OFF	0	0	0	0	0	0	0	1	1	1	1	\$0F	Display on, Cursor on, Cursor blink
Clear Display	0	0	0	0	0	0	0	0	0	0	1	\$01	Clear display, place cursor to 1st. col. /1st. row

Adress:
1st. line \$00..\$13
2nd. line \$20..\$33
3rd. line \$40..\$53
4th. line \$60..\$73

Please make shure that software will check busy-flag before writing any command !

CHARACTER SET

Beside there's a copy of built.in character set. In addition to that up to 8 individual character can be created.

CONTRAST ADJUSTMENT

Contrast will be set by pin 3 (VCI). Module EA DIP203 comes with built-in temperature compensation for -20..+70°C as a standard; any contrast adjustment while operation is no longer required.

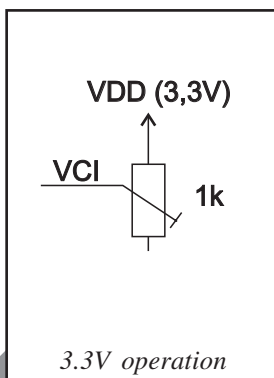

Upper bit	Lower bit	LLLL	LLLH	LLHL	LLHH	LHLL	LHLH	LHHL	LHLL	HLHH	HLHL	HLHL	HLHL	HHLL	HHHL	HHHL	HHHH
CG RAM (1)		█	█	█	█	█	█	█	█	█	█	█	█	█	█	█	█
(2)		█	█	█	█	█	█	█	█	█	█	█	█	█	█	█	█
(3)		█	█	█	█	█	█	█	█	█	█	█	█	█	█	█	█
(4)		█	█	█	█	█	█	█	█	█	█	█	█	█	█	█	█
(5)		█	█	█	█	█	█	█	█	█	█	█	█	█	█	█	█
(6)		█	█	█	█	█	█	█	█	█	█	█	█	█	█	█	█
(7)		█	█	█	█	█	█	█	█	█	█	█	█	█	█	█	█
(8)		█	█	█	█	█	█	█	█	█	█	█	█	█	█	█	█
(1)		█	█	█	█	█	█	█	█	█	█	█	█	█	█	█	█
(2)		█	█	█	█	█	█	█	█	█	█	█	█	█	█	█	█
(3)		█	█	█	█	█	█	█	█	█	█	█	█	█	█	█	█
(4)		█	█	█	█	█	█	█	█	█	█	█	█	█	█	█	█
(5)		█	█	█	█	█	█	█	█	█	█	█	█	█	█	█	█
(6)		█	█	█	█	█	█	█	█	█	█	█	█	█	█	█	█
(7)		█	█	█	█	█	█	█	█	█	█	█	█	█	█	█	█
(8)		█	█	█	█	█	█	█	█	█	█	█	█	█	█	█	█

CREATING YOUR OWN CHARACTERS

All these character display modules got the feature to create 8 own characters (ASCII Codes 0..7) in addition to the 240 ROM fixed codes.

- 1.) The command "CG RAM Address Set" defines the ASCII code (Bit 3,4,5) and the dot line (Bit 0,1,2) of the new character. Example demonstrates creating ASCII code \$00.
- 2.) Doing 8 times the write command "Data Write" defines line by line the new character. 8th. byte stands for the cursor line.
- 3.) The new defined character can be used as a "normal" ASCII code (0..7); use with "DD RAM Address Set" and "Data Write".

Set CG RAM Address				Data				
Adresse		Hex	Bit		Hex			
7	6	5	4			3	2	1
0	1	0	0	0	0	0	0	\$04
				0	0	1	0	\$04
				0	1	0	0	\$04
				0	1	1	0	\$04
				1	0	0	0	\$15
				1	0	1	0	\$0E
				1	1	0	0	\$04
				1	1	1	0	\$00

DRIVING WITH 5V-SYSTEMS

The supply voltage of the display is necessarily 3.3V. If a 5V-system is used, the level have to be adapted. For example you can use a bidirectional levelshifter (e.g. PS 74LVC4245A), like shown in the opposite figure.

COMPATIBILITY WITH EA DIP204-6

The displays of EA DIP203 and EA DIP204 series are electrically and mechanically identical to each other running with 3.3V supply mode. Merely a 5V supply is not acceptable with the new EA DIP203 series.

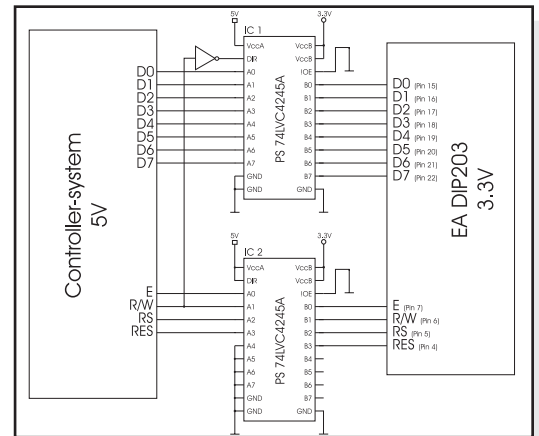

DIMENSIONS

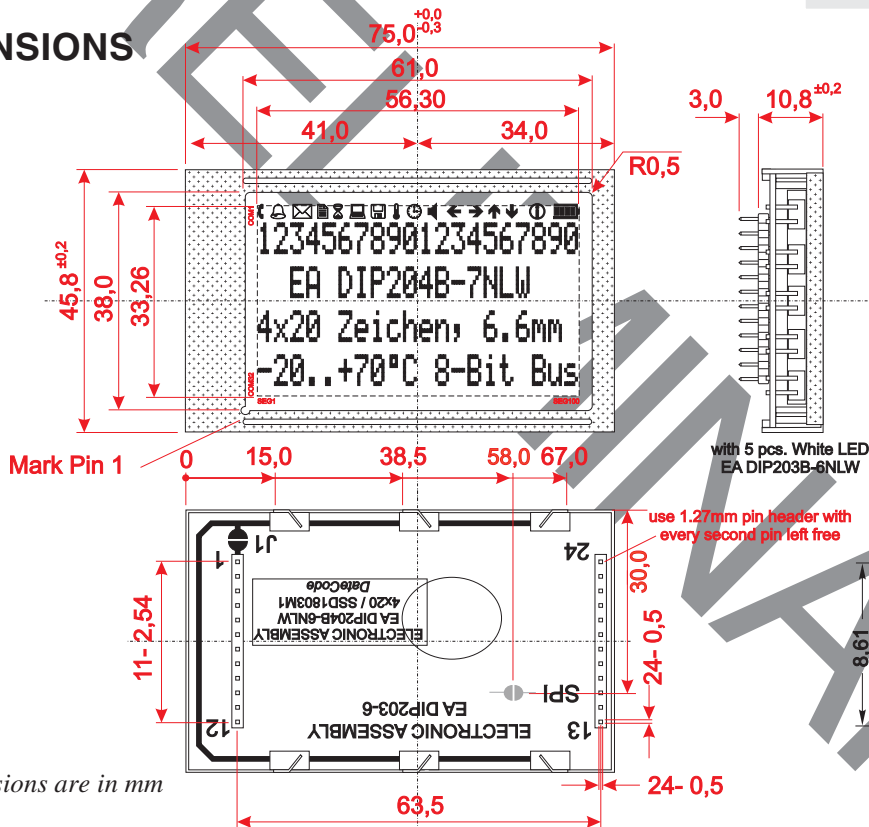

Note:
LC-Displays are generally not suited to wave or reflow soldering. Temperatures of over 90°C can cause lasting damage.

all dimensions are in mm

DRIVING THE SYMBOLS

After power-on symbols will be set accidental. To switch off them all please refer to the example of initializing on page 3. To display an individual symbol have a look at the program example at the right.

Each symbol can be displayed in normal (solid) and blinking style.

Example program to display an icon (8 bit mode interface)													
Command	RE Bit	RS	R/W	DB7	DB6	DB5	DB4	DB3	DB2	DB1	DB0	Hex	Note
Busy-Flag / Address read	0	0	1	BF	AC								perhaps store current DDRAM address: read AC and save as LASTADR=AC
Function Set	0	0	0	0	0	1	1	0	1	1	0	\$36	Set to 8 bit data length, RE=1, Blink enable BE=1
Set SEGRAM adr	1	0	0	0	1	0	0	0	0	1	0	\$42	Set Icon-RAM address to \$02 (letter symbol)
Write Data	1	1	0	0	0	0	0	1	0	0	0	\$10	Write \$10 to display symbol
Function Set	1	0	0	0	0	1	1	0	0	0	0	\$30	Set to 8 bit data length, extension bit RE=0
Set DDRAM adr	0	0	0	1	LASTADR						\$80	Restore DDRAM address	

Icon - Symbols																				
SEGRAM address	\$00	\$01	\$02	\$03	\$04	\$05	\$06	\$07	\$08	\$09	\$0A	\$0B	\$0C	\$0D	\$0E	\$0F	\$0F	\$0F	\$0F	\$0F
data solid	\$10	\$10	\$10	\$10	\$10	\$10	\$10	\$10	\$10	\$10	\$10	\$10	\$10	\$10	\$10	\$1F	\$1E	\$1C	\$18	\$10
data blink (BE=1)	\$50	\$50	\$50	\$50	\$50	\$50	\$50	\$50	\$50	\$50	\$50	\$50	\$50	\$50	\$50	\$50	\$50	\$50	\$50	\$50

Компания «Life Electronics» занимается поставками электронных компонентов импортного и отечественного производства от производителей и со складов крупных дистрибьюторов Европы, Америки и Азии.

С конца 2013 года компания активно расширяет линейку поставок компонентов по направлению коаксиальный кабель, кварцевые генераторы и конденсаторы (керамические, пленочные, электролитические), за счёт заключения дистрибьюторских договоров

Мы предлагаем:

- Конкурентоспособные цены и скидки постоянным клиентам.
- Специальные условия для постоянных клиентов.
- Подбор аналогов.
- Поставку компонентов в любых объемах, удовлетворяющих вашим потребностям.
- Приемлемые сроки поставки, возможна ускоренная поставка.
- Доставку товара в любую точку России и стран СНГ.
- Комплексную поставку.
- Работу по проектам и поставку образцов.
- Формирование склада под заказчика.
- Сертификаты соответствия на поставляемую продукцию (по желанию клиента).
- Тестирование поставляемой продукции.
- Поставку компонентов, требующих военную и космическую приемку.
- Входной контроль качества.
- Наличие сертификата ISO.

В составе нашей компании организован Конструкторский отдел, призванный помогать разработчикам, и инженерам.

Конструкторский отдел помогает осуществить:

- Регистрацию проекта у производителя компонентов.
- Техническую поддержку проекта.
- Защиту от снятия компонента с производства.
- Оценку стоимости проекта по компонентам.
- Изготовление тестовой платы монтаж и пусконаладочные работы.



Тел: +7 (812) 336 43 04 (многоканальный)

Email: org@lifeelectronics.ru