

Mini-Com® Stainless Steel Faceplates

PANDUIT®

SPECIFICATION SHEET

specifications

Stainless steel faceplates with labels shall be available in 2, 4, and 6-port single gang and various double gang configurations. Each faceplate shall accept copper, fiber, and AV modules that snap in and out without the use of tools. Faceplates shall have flush profile, and optional built in label pocket for easy identification. Stainless steel material shall be attached to a high impact ABS backing to provide a durable faceplate with brushed stainless steel finish.



technical information

Material:	304 grade stainless steel with satin finish is mounted on ABS backing and is suitable for hospital and laboratory environments; easy to clean
Mounting options:	Screw holes spaced for single and double gang openings; compatible with Panduit wall board adapters
Packaging:	Supplied with two or four 1" long, #6-32 slotted head screws; faceplates packaged one per bag, ten per box; labeled faceplates include label kit

key features and benefits

Durable	Impact resistant material supports installations in high traffic
Modular	Accepts all Mini-Com® Modules which snap in and out for easy moves, adds, and changes
Various port densities	Provides design flexibility
Flush mounting	Provides superior aesthetics
Label version available	Can be clearly identified with optional labels for port identification
Sloped recessed	Allows proper bend radius

applications

Mini-Com® Stainless Steel Faceplates are ideal for use in hospitals, laboratories, schools, and office environments. The faceplates are compatible with most standard single and double gang electrical boxes, wall board

adapters, and raceway mounting brackets. These durable stainless steel faceplates are available with or without labels. Printable labels are available for compliance to the ANSI/TIA-606B labeling standard.

Single Gang Sloped Recessed Faceplates with Labels

2-port:	CFPSL2S
4-port:	CFPSL4S

Single Gang Faceplates with Labels*

2-port:	CFPL2SY
4-port:	CFPL4SY
6-port:	CFPL6SY

Label Options for Single Gang Faceplates

Laser/ink jet:	C195X040Y1J
PanTher™ LS8E:	C196X040Y1C

Double Gang Faceplates with Labels

4-port:	CFPL4S-2GY
6-port:	CFPL6S-2GY
8-port:	CFPL8S-2GY
10-port:	CFPL10S-2GY

Label Options for Double Gang Faceplates

Laser/ink jet:	C288X040Y1J
PanTher™ LS8E:	C288X040Y1C

Single Gang Faceplates without Labels*

2-port:	CFP2SY
4-port:	CFP4SY
6-port:	CFP6SY

Label Options for Single Gang Faceplates

Laser/ink jet	
2 or 4-port:	C061X030FJJ
6-port:	C188X030FJJ
PanTher™ LS8E	
2 or 4-port:	C061X030FJC
6-port:	C188X030FJC

Double Gang Faceplates without Labels

4-port:	CFP4S-2GY
8-port:	CFP8S-2GY
10-port:	CFP10S-2GY

Label Options for Double Gang Faceplates

Laser/ink jet	
4-port:	C061X030FJJ
8-port:	C125X030FJJ
10-port:	C315X030FJJ
PanTher™ LS8E	
4-port:	C061X030FJC
8-port:	C125X030FJC
10-port:	C315X030FJC

Wall Board Adapters

Single gang:	MWBA1
Double gang	MWBA-2G

*Four and six-port, single gang faceplates must be installed on a 1.9" wide (or wider) electrical back box.

Mini-Com® Stainless Steel Faceplates

2, 4, and 6-port single gang faceplate with label

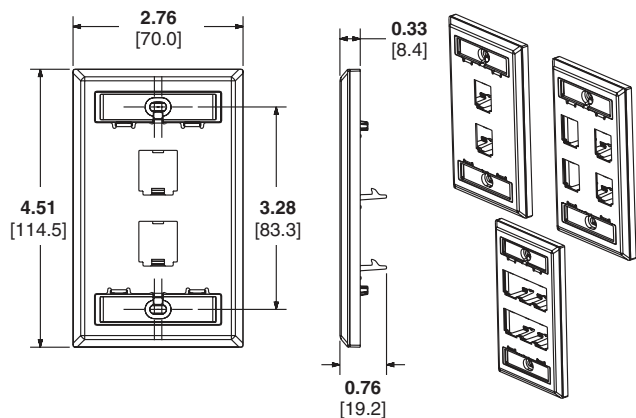

4, 8, and 10-port double gang faceplate with label

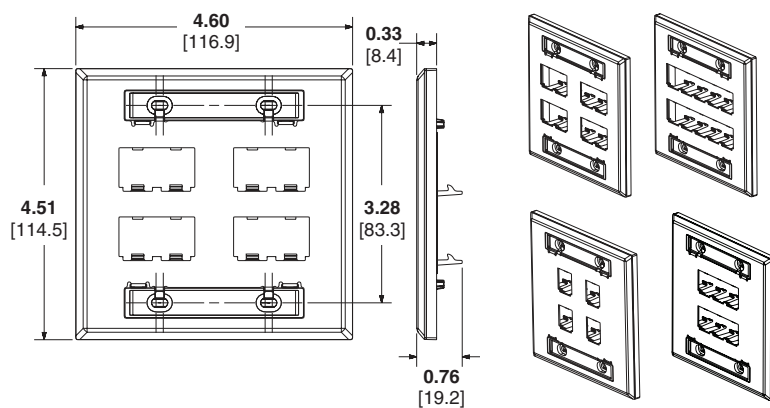

2, 4, and 6-port single gang faceplates

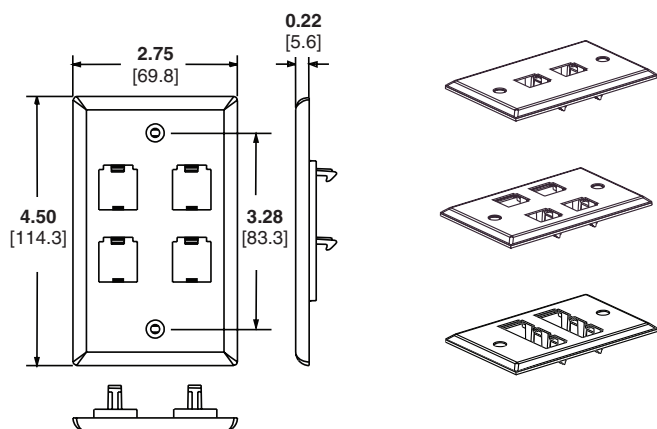

4, 8, and 10-port double gang faceplates

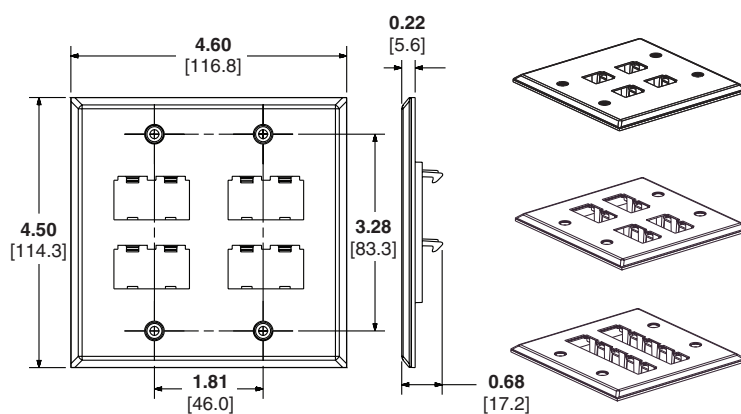

Dimensions are in inches. [Dimensions in brackets are metric.]

Mini-Com® Stainless Steel Faceplates

2-port sloped recessed single gang faceplate with label

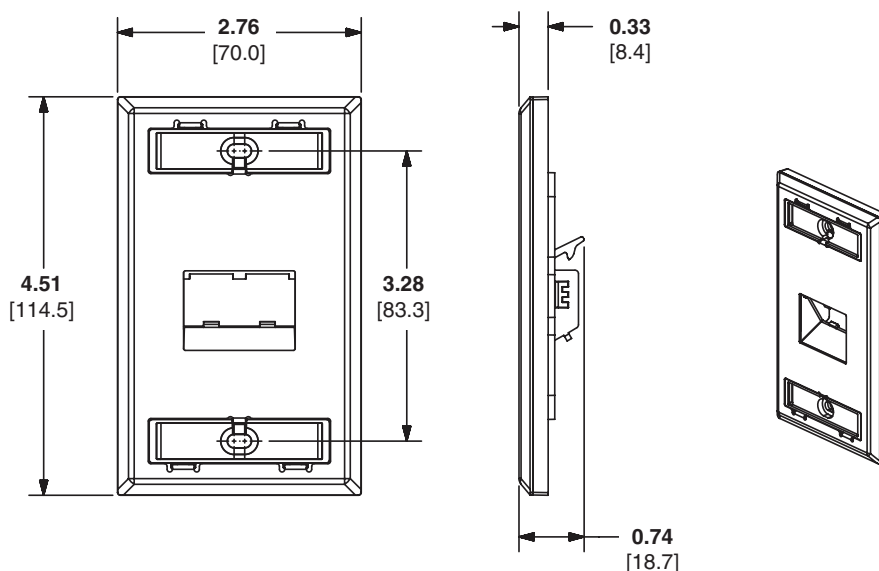

4-port sloped recessed single gang faceplate with label

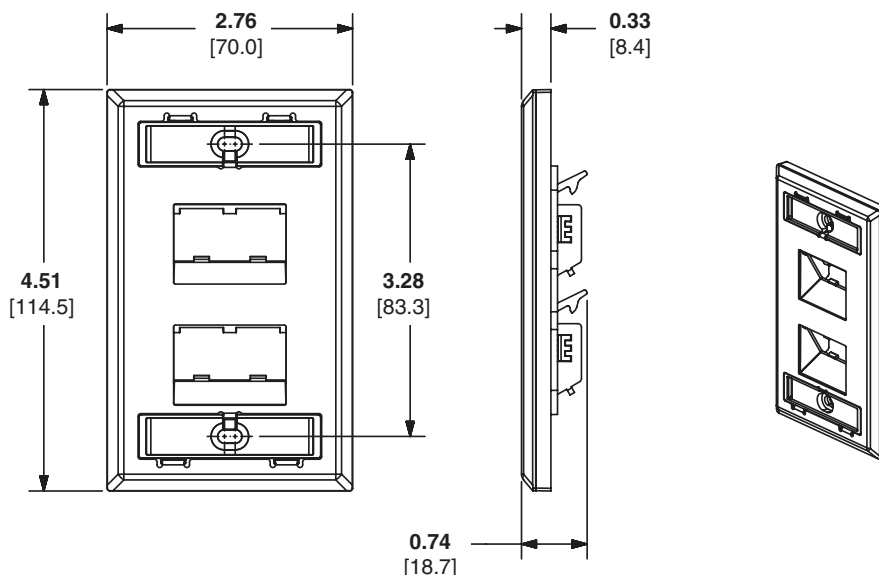

Dimensions are in inches. [Dimensions in brackets are metric.]

WORLDWIDE SUBSIDIARIES AND SALES OFFICES

PANDUIT CANADA
Markham, Ontario
cs-cdn@panduit.com
Phone: 800.777.3300

PANDUIT EUROPE LTD.
London, UK
cs-emea@panduit.com
Phone: 44.20.8601.7200

PANDUIT SINGAPORE PTE. LTD.
Republic of Singapore
cs-ap@panduit.com
Phone: 65.6305.7575

PANDUIT JAPAN
Tokyo, Japan
cs-japan@panduit.com
Phone: 81.3.6863.6000

PANDUIT LATIN AMERICA
Guadalajara, Mexico
cs-la@panduit.com
Phone: 52.33.3777.6000

PANDUIT AUSTRALIA PTY. LTD.
Victoria, Australia
cs-aus@panduit.com
Phone: 61.3.9794.9020

For a copy of Panduit product warranties, log on to www.panduit.com/warranty

For more information

Visit us at www.panduit.com

Contact Customer Service by email: cs@panduit.com
or by phone: 800.777.3300

PANDUIT®

©2014 Panduit Corp.
ALL RIGHTS RESERVED.
OTSP45--WW-ENG
Replaces WW-OTSP16
9/2014

Компания «Life Electronics» занимается поставками электронных компонентов импортного и отечественного производства от производителей и со складов крупных дистрибьюторов Европы, Америки и Азии.

С конца 2013 года компания активно расширяет линейку поставок компонентов по направлению коаксиальный кабель, кварцевые генераторы и конденсаторы (керамические, пленочные, электролитические), за счёт заключения дистрибьюторских договоров

Мы предлагаем:

- Конкурентоспособные цены и скидки постоянным клиентам.
- Специальные условия для постоянных клиентов.
- Подбор аналогов.
- Поставку компонентов в любых объемах, удовлетворяющих вашим потребностям.
- Приемлемые сроки поставки, возможна ускоренная поставка.
- Доставку товара в любую точку России и стран СНГ.
- Комплексную поставку.
- Работу по проектам и поставку образцов.
- Формирование склада под заказчика.
- Сертификаты соответствия на поставляемую продукцию (по желанию клиента).
- Тестирование поставляемой продукции.
- Поставку компонентов, требующих военную и космическую приемку.
- Входной контроль качества.
- Наличие сертификата ISO.

В составе нашей компании организован Конструкторский отдел, призванный помогать разработчикам, и инженерам.

Конструкторский отдел помогает осуществить:

- Регистрацию проекта у производителя компонентов.
- Техническую поддержку проекта.
- Защиту от снятия компонента с производства.
- Оценку стоимости проекта по компонентам.
- Изготовление тестовой платы монтаж и пусконаладочные работы.



Тел: +7 (812) 336 43 04 (многоканальный)

Email: org@lifeelectronics.ru