

REVISONS		DATE	DN	APVD
LOC	DIST	DESCRIPTION		
D1	REVISED PER ECO-11-005030	11MAR11	RK	HMR

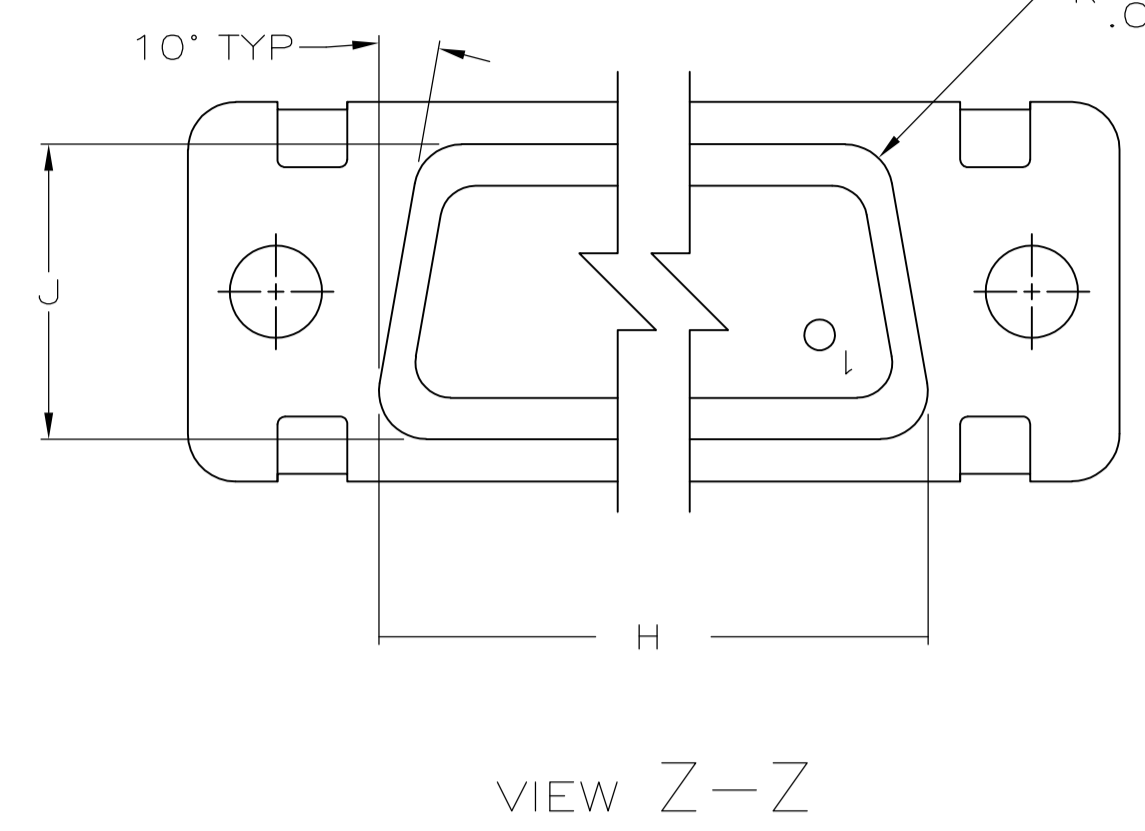

- 1. SEE SHEET 2 FOR RECOMMENDED P.C. BOARD LAYOUT. TRUE POSITION TOLERANCE FOR P.C. BOARD LAYOUT IS .010 [0.25] AT MAX MATERIAL CONDITION. SUGGESTED BOARD THICKNESS IS .125 [3.18]
- 2. THE CONNECTORS DESCRIBED IN THIS DOCUMENT MEET THE REQUIREMENTS OF MIL-C-24308 AND MATE WITH ANY PLUG CONNECTOR WITH SAME INSERT ARRANGEMENT.
- 3. MARK WITH .047 [1.19]-.062 [1.57] HIGH CHARACTERS. FAR SIDE REFERS TO THE WIDE SIDE OF THE KEYSTONE. NEAR SIDE REFERS TO THE NARROW SIDE OF THE KEYSTONE. IF THE REAR SHELL IS TOO SMALL FOR THE ENTIRE MILITARY PART NUMBER, MARKING SHALL BE LOCATED AS FOLLOWS:
  - A. "M24308" ON FRONT SHELL, FAR SIDE.
  - B. SLASH SHEET AND DASH NUMBER ON REAR SHELL, FAR SIDE.
  - C. "AMP" AND DATE CODE ON FRONT SHELL, NEAR SIDE.
  - D. PART NUMBER ON REAR SHELL, NEAR SIDE.

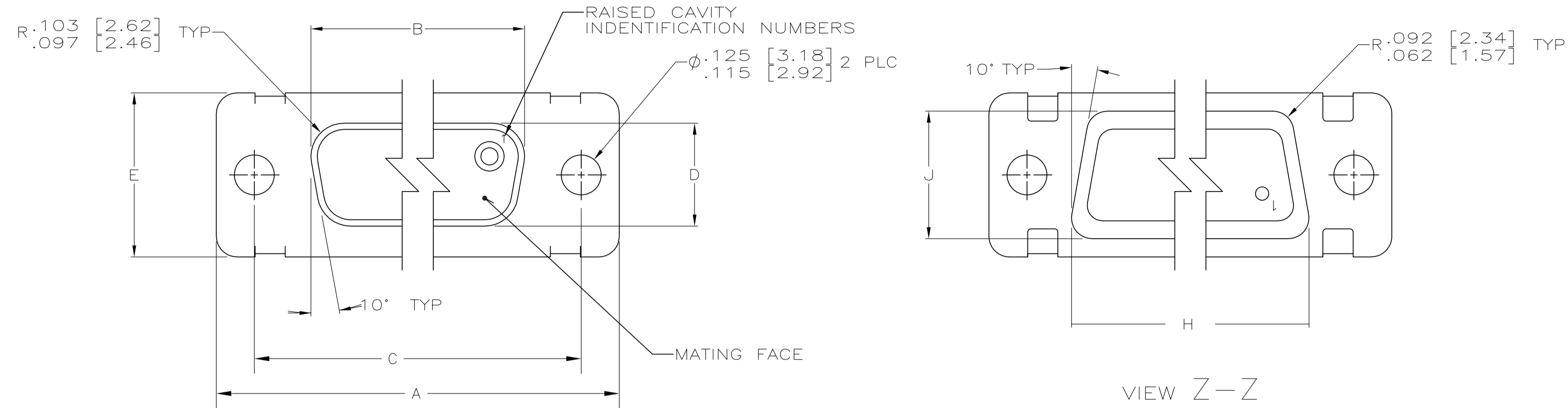
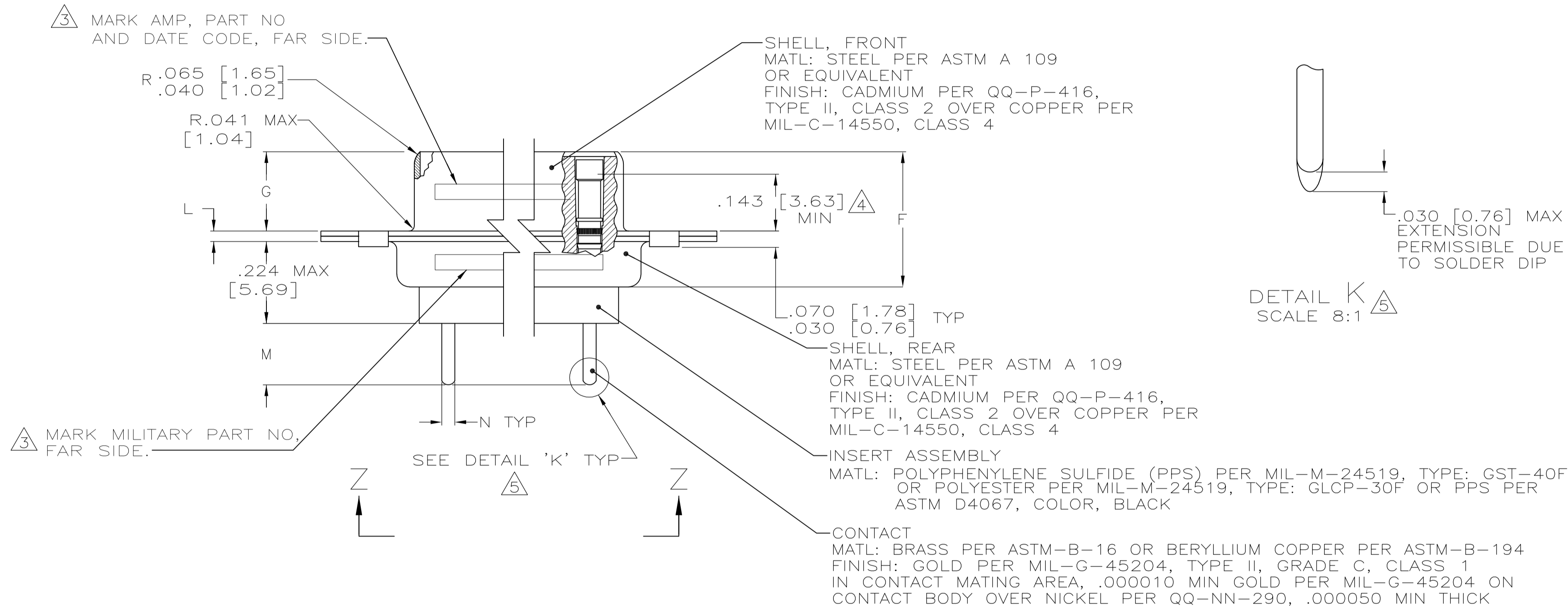

DETAIL K SCALE 8:1

- 4. POINT OF ELECTRICAL ENGAGEMENT - AS MEASURED WITH A .0390 [0.991]-.0393 [0.998] DIA SQUARE ENDED TEST PIN.
- 5. SOLDER DIP PER MIL-STD-2000 COMPOSITION Sn63 CONFORMING TO QQ-S-571. COVERAGE SHALL BE COMPLETE TO A DISTANCE .020 [0.51] MAX FROM INSERT ASSEMBLY.
- 6. THE SOLDER DIP PROCESS IS PERFORMED SUBSEQUENT TO THE COMPLETION OF PRODUCTION OF THE MILITARY QUALIFIED CONNECTOR. DIMENSIONS APPLY PRIOR TO SOLDER DIPPING.
- 7. SPACERS (QTY 2) ARE SUPPLIED WITH CONNECTORS (NOT ATTACHED TO THE CONNECTOR).
- 8. DIMENSIONS AND TOLERANCES PER ANSI Y14.5M-1982.
- 9. THIS DRAWING SHALL BE INTERPRETED IN ACCORDANCE WITH APPLICABLE STANDARDS LISTED IN MIL-STD-100.

N	M	L	J	H	G	F	E	D	C	B	A	INSERT ARRANGEMENT	NO OF POS	SHELL SIZE	MILITARY P/N ON CONNECTOR	P/N ON CONNECTOR	PART NUMBER
.033 [0.84] .027 [0.69]	.176 [4.47] .136 [3.45]	.040 [1.02] .020 [0.51]	.544 [13.82] .524 [13.31]	2.188 [55.58] 2.168 [55.07]	.248 [6.30] .238 [6.05]	.439 [11.15] .419 [10.64]	.620 [15.75] .590 [14.99]	.428 [10.87] .418 [10.62]	2.411 [61.24] 2.401 [60.99]	2.069 [52.55] 2.059 [52.30]	2.650 [67.31] 2.620 [66.55]	MS18277-1	50	5	M24308/23-5F	443975-5	1-443975-0
												MS18276-1	37	4	M24308/23-4F	443975-4	443975-9
.432 [10.97] .412 [10.46]	1.635 [41.53] 1.615 [41.02]	1.093 [27.76] 1.073 [27.25]	.544 [13.82] .524 [13.31]	2.188 [55.58] 2.168 [55.07]	.248 [6.30] .238 [6.05]	.439 [11.15] .419 [10.64]	.620 [15.75] .590 [14.99]	.428 [10.87] .418 [10.62]	2.411 [61.24] 2.401 [60.99]	2.069 [52.55] 2.059 [52.30]	2.650 [67.31] 2.620 [66.55]	MS18275-1	25	3	M24308/23-3F	443975-3	443975-8
												MS18274-1	15	2	M24308/23-2F	443975-2	443975-7
.769 [19.53] .749 [19.02]	1.635 [41.53] 1.615 [41.02]	1.093 [27.76] 1.073 [27.25]	.544 [13.82] .524 [13.31]	2.188 [55.58] 2.168 [55.07]	.248 [6.30] .238 [6.05]	.439 [11.15] .419 [10.64]	.620 [15.75] .590 [14.99]	.428 [10.87] .418 [10.62]	2.411 [61.24] 2.401 [60.99]	2.069 [52.55] 2.059 [52.30]	2.650 [67.31] 2.620 [66.55]	MS18273-1	9	1	M24308/23-1F	443975-1	443975-6
												MS18277-1	50	5	M24308/23-5F	443975-5	443975-5
.195 MAX [4.95]	.120 REF [3.05]	.033 [0.84] .027 [0.69]	.544 [13.82] .524 [13.31]	2.188 [55.58] 2.168 [55.07]	.248 [6.30] .238 [6.05]	.439 [11.15] .419 [10.64]	.620 [15.75] .590 [14.99]	.428 [10.87] .418 [10.62]	2.411 [61.24] 2.401 [60.99]	2.069 [52.55] 2.059 [52.30]	2.650 [67.31] 2.620 [66.55]	MS18276-1	37	4	M24308/23-4F	443975-4	443975-4
												MS18275-1	25	3	M24308/23-3F	443975-3	443975-3
.246±.003 [6.25±0.08]	.120 REF [3.05]	.033 [0.84] .027 [0.69]	.544 [13.82] .524 [13.31]	2.188 [55.58] 2.168 [55.07]	.248 [6.30] .238 [6.05]	.439 [11.15] .419 [10.64]	.620 [15.75] .590 [14.99]	.428 [10.87] .418 [10.62]	2.411 [61.24] 2.401 [60.99]	2.069 [52.55] 2.059 [52.30]	2.650 [67.31] 2.620 [66.55]	MS18274-1	15	2	M24308/23-2F	443975-2	443975-2
												MS18273-1	9	1	M24308/23-1F	443975-1	443975-1



SPACER  
MATL: ALUMINUM ALLOY PER ASTM B 211  
FINISH: IRIDITE PER MIL-C-5541,  
CLASS 3, COLOR GOLD

THIS DRAWING IS A CONTROLLED DOCUMENT.

DIMENSIONS: INCHES	TOLERANCES UNLESS OTHERWISE SPECIFIED:	0 PLC ± -	1 PLC ± -	2 PLC ± -	3 PLC ± -	4 PLC ± -	ANGLES ± °
MATERIAL SEE CALLOUTS	FINISH SEE CALLOUTS	WEIGHT	SIZE	CODE	DRAWING NO	RESTRICTED TO	

APPROVED: J.A. BAKER, G. OVER, G. OVER, G. OVER, G. OVER

AMPLITE RECEPACLE ASSY W/ SIZE 20 POSTED PC BOARD CONTACTS SERIES 109, SIZES 1 THRU 5

SCALE 4:1 SHEET 1 OF 2 REV D1

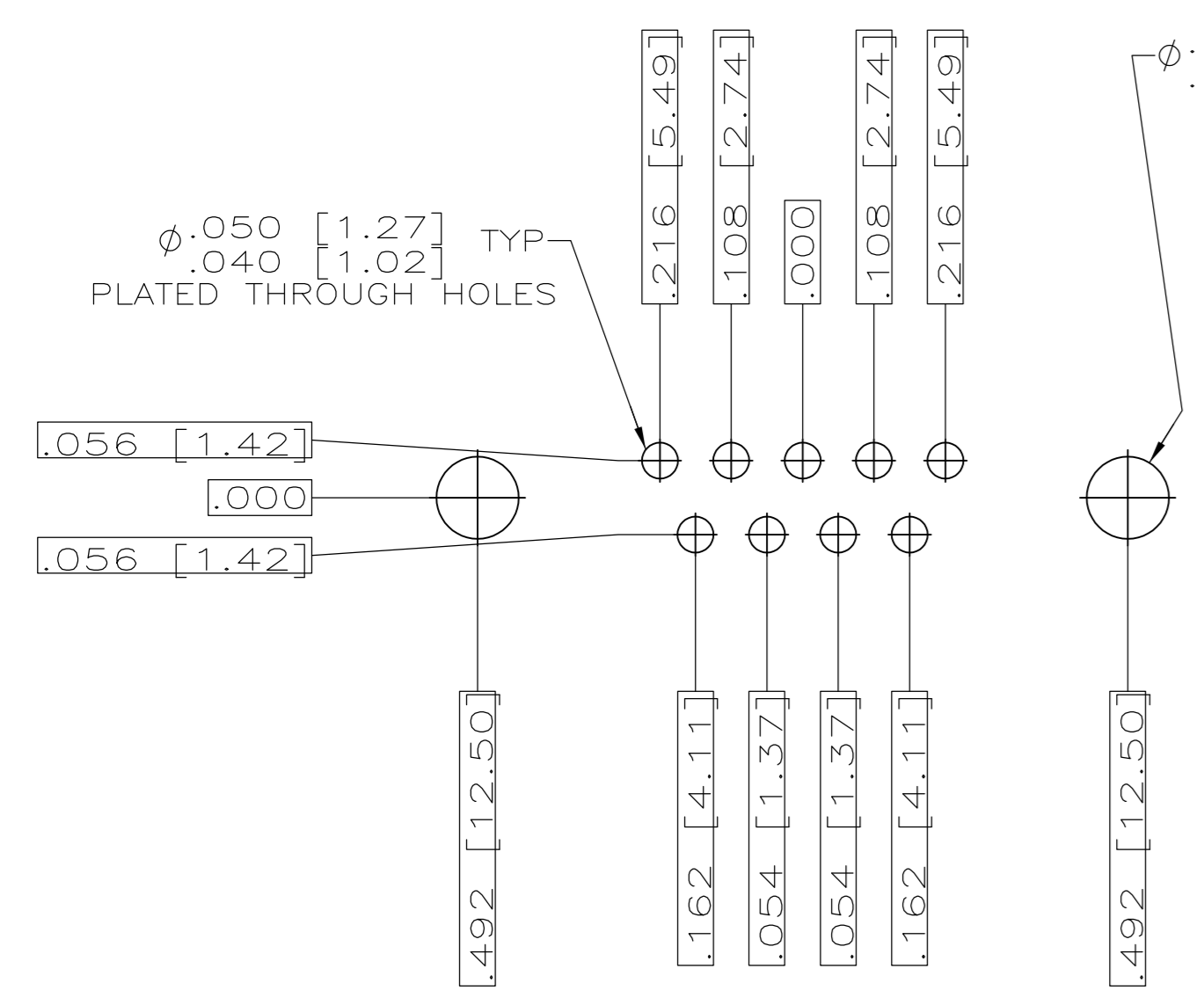

RECOMMENDED P.C. BOARD LAYOUT  
SHELL SIZE 1 (9 POSITION)  $\triangle$

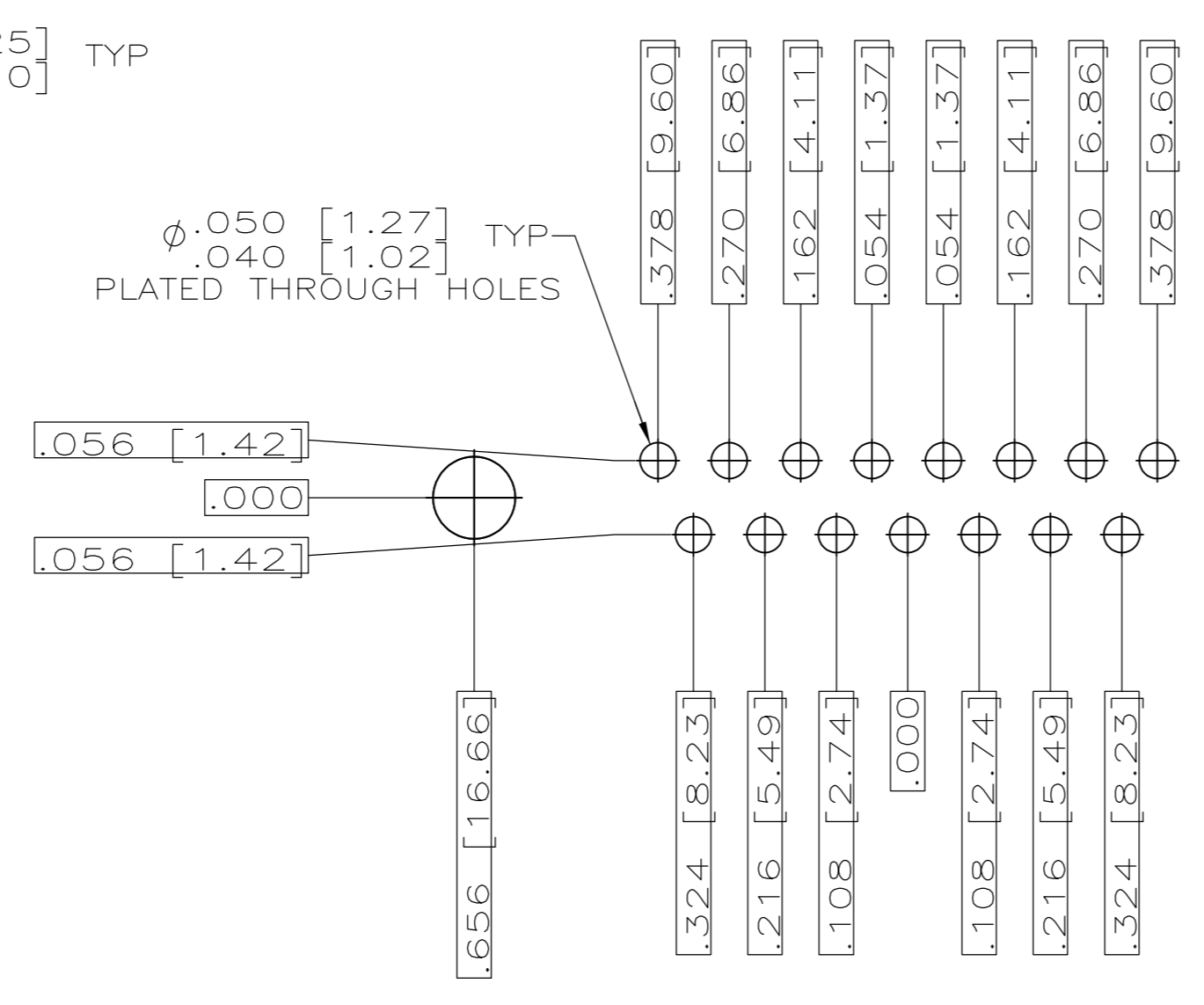

RECOMMENDED P.C. BOARD LAYOUT  
SHELL SIZE 2 (15 POSITION)  $\triangle$

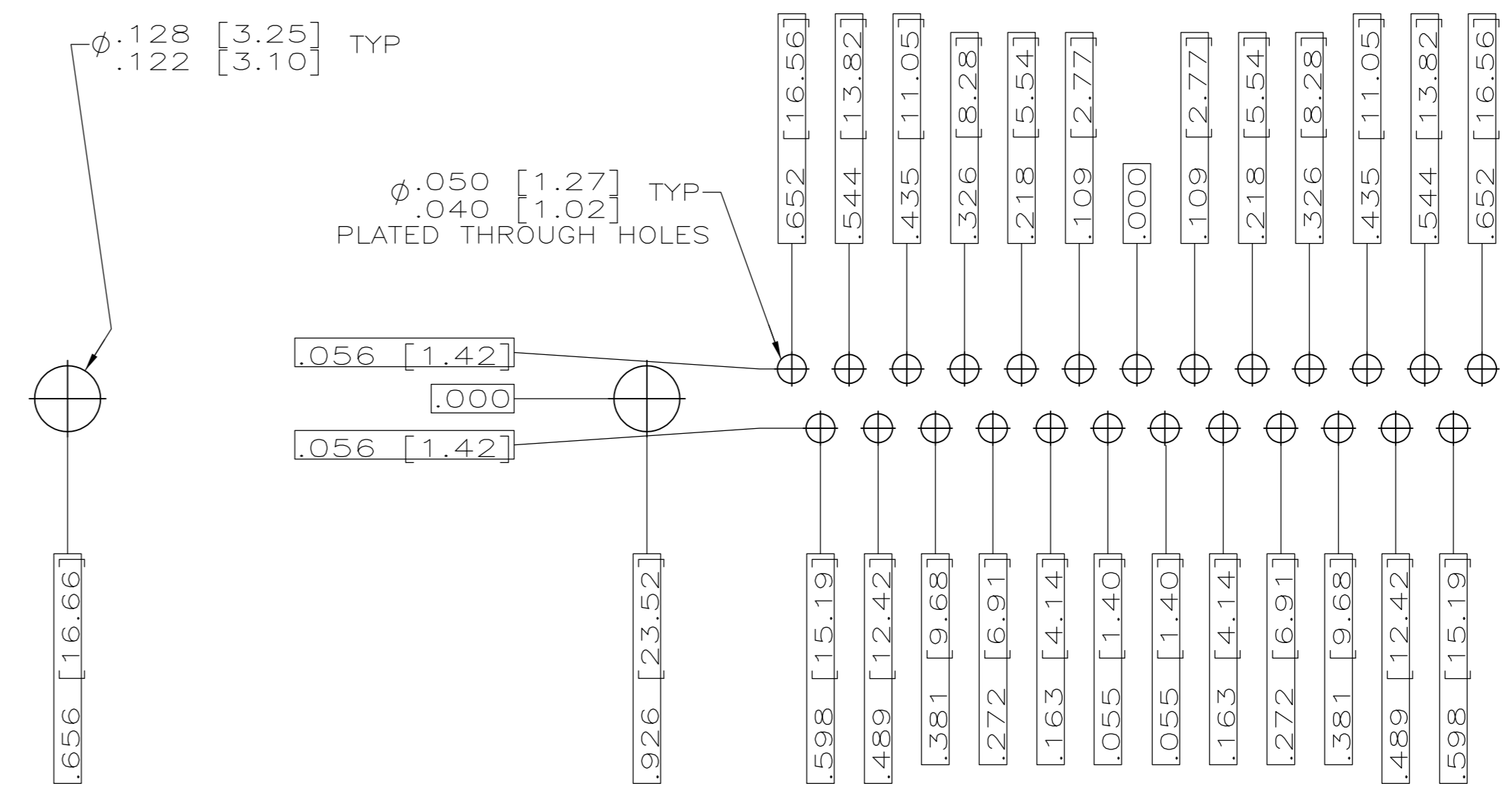

RECOMMENDED P.C. BOARD LAYOUT  
SHELL SIZE 3 (25 POSITION)  $\triangle$

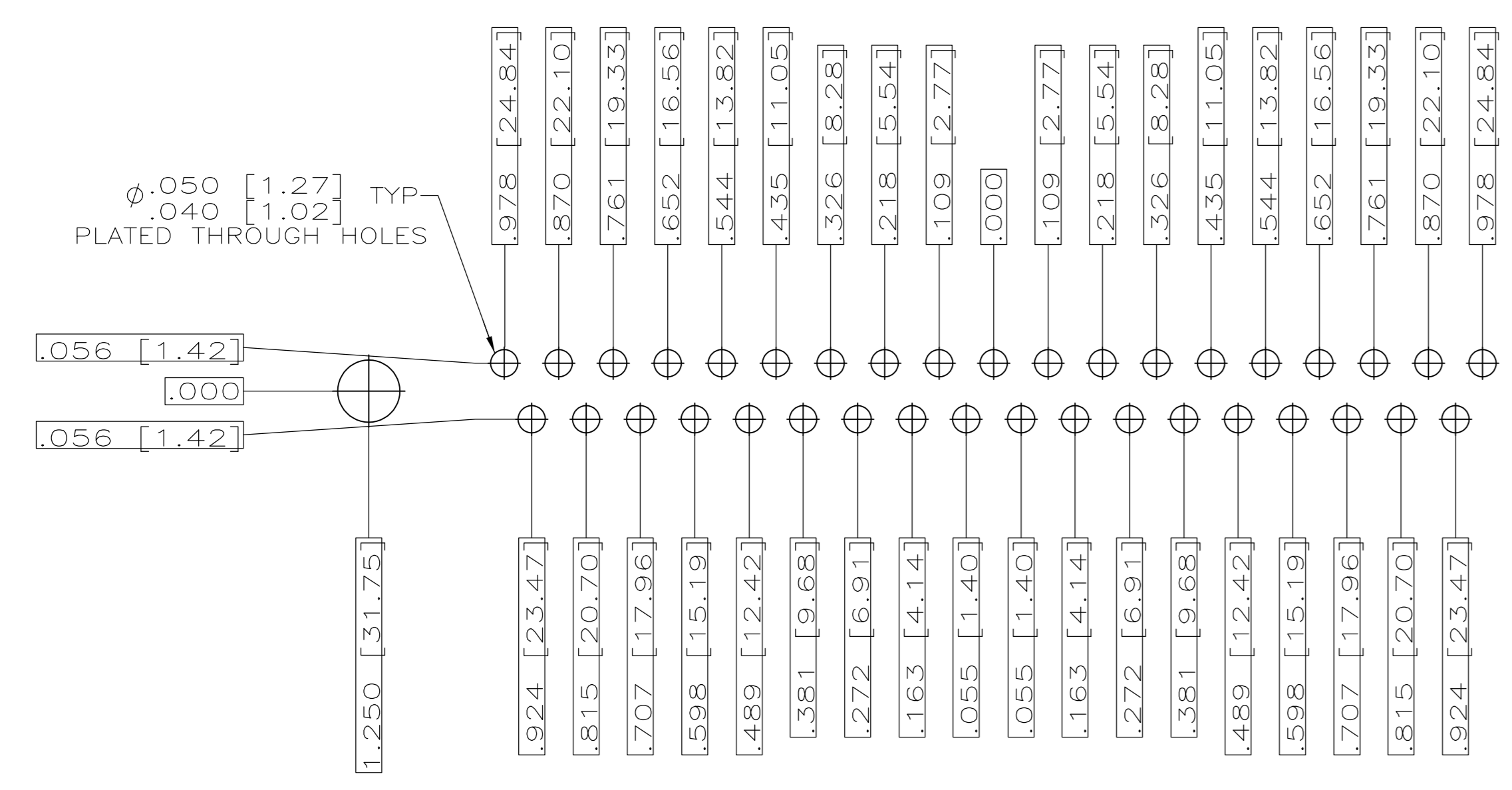

RECOMMENDED P.C. BOARD LAYOUT  
SHELL SIZE 4 (37 POSITION)  $\triangle$

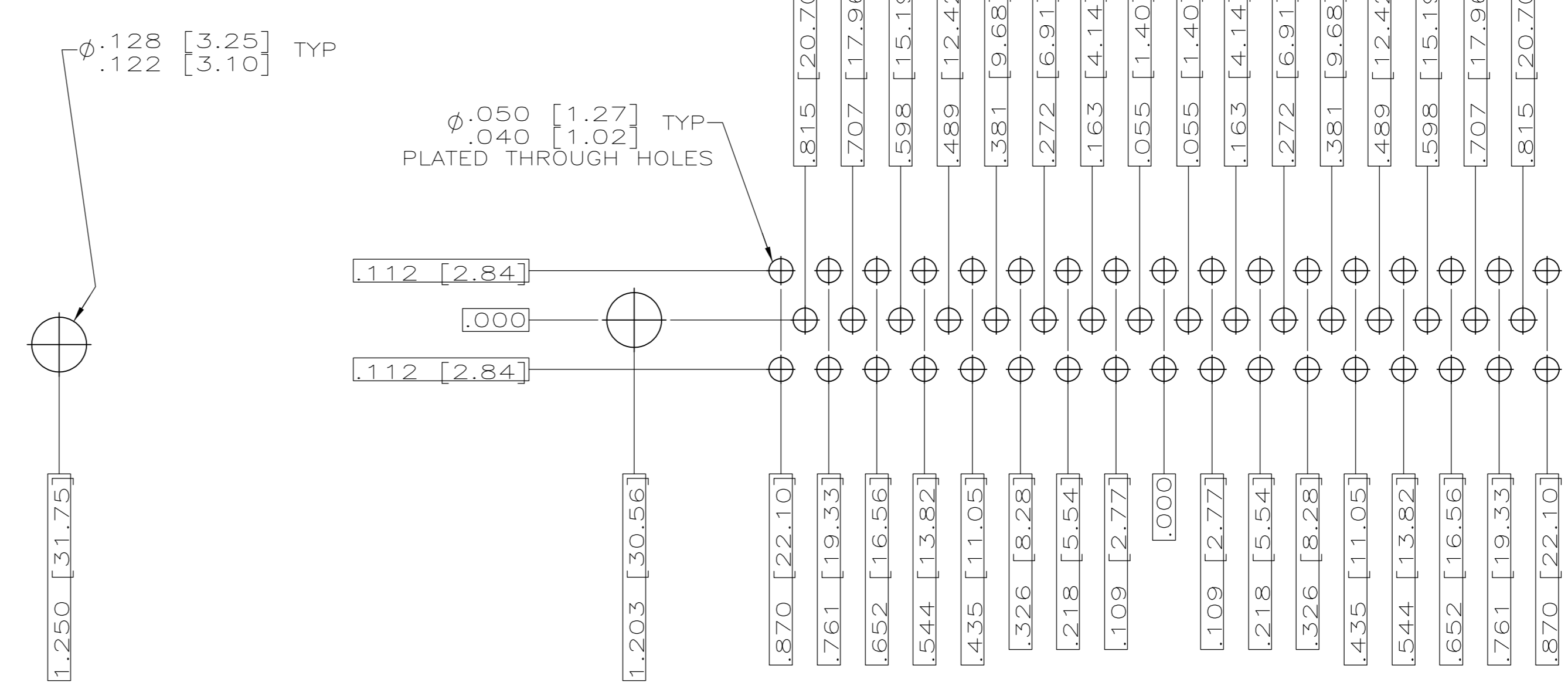

RECOMMENDED P.C. BOARD LAYOUT  
SHELL SIZE 5 (50 POSITION)  $\triangle$

THIS DRAWING IS A CONTROLLED DOCUMENT.		DWN J.A. Baker	OSMAY97		TE Connectivity	
DIMENSIONS: INCHES		CHK G. OVER	15MAY98		AMPLIMITE RECEPTACLE ASSY WITH SIZE 20 STRAIGHT POSTED P.C. BOARD CONTACTS, SERIES 109.	
TOLERANCES UNLESS OTHERWISE SPECIFIED:		APVD		NAME		
0 PLC ± .005		PRODUCT SPEC		MIL-C-24308		
1 PLC ± .005		APPLICATION SPEC		SIZE		
2 PLC ± .005		MATERIAL		DATE CODE		
3 PLC ± .005		FINISH		DRAWING NO		
4 PLC ± .005		MATERIAL		RESTRICTED TO		
SEE CALLOUTS		WEIGHT		A1 00779		
SEE CALLOUTS		CUSTOMER DRAWING		SCALE 4:1 SHEET 2 OF 2 REV D1		

Компания «Life Electronics» занимается поставками электронных компонентов импортного и отечественного производства от производителей и со складов крупных дистрибьюторов Европы, Америки и Азии.

С конца 2013 года компания активно расширяет линейку поставок компонентов по направлению коаксиальный кабель, кварцевые генераторы и конденсаторы (керамические, пленочные, электролитические), за счёт заключения дистрибьюторских договоров

Мы предлагаем:

- Конкуренспособные цены и скидки постоянным клиентам.
- Специальные условия для постоянных клиентов.
- Подбор аналогов.
- Поставку компонентов в любых объемах, удовлетворяющих вашим потребностям.
- Приемлемые сроки поставки, возможна ускоренная поставка.
- Доставку товара в любую точку России и стран СНГ.
- Комплексную поставку.
- Работу по проектам и поставку образцов.
- Формирование склада под заказчика.
- Сертификаты соответствия на поставляемую продукцию (по желанию клиента).
- Тестирование поставляемой продукции.
- Поставку компонентов, требующих военную и космическую приемку.
- Входной контроль качества.
- Наличие сертификата ISO.

В составе нашей компании организован Конструкторский отдел, призванный помогать разработчикам, и инженерам.

Конструкторский отдел помогает осуществить:

- Регистрацию проекта у производителя компонентов.
- Техническую поддержку проекта.
- Защиту от снятия компонента с производства.
- Оценку стоимости проекта по компонентам.
- Изготовление тестовой платы монтаж и пусконаладочные работы.



Тел: +7 (812) 336 43 04 (многоканальный)

Email: [org@lifeelectronics.ru](mailto:org@lifeelectronics.ru)