

**Variable Transformers
Series 1500 • 9.5 to 15.0 Amperes**



1500 Series

The 1510/1520 Series Variable Transformers are highly reliable, dependable and accurate AC control devices. The 1510, 120 volt unit is rated at 15 amperes for constant current loads; while the 1520, 240 volt unit is rated at 9.5 amperes for constant current loads. Constant impedance ratings are listed in the specifications. They can be operated at frequencies between 50 and 2000 hertz with derating at higher than rated frequency.

Uncased models have the shaft extending from the base end. This shaft is fully adjustable and can be extended from either end for general utility mounting. Cased styles are available in either "C" style (featuring protective screening over the coil assembly

only) or the "CT" style (which also includes a terminal box cover with knock-outs to accept conduit).

Motor driven units are available in single, two and three ganged assemblies; cased or uncased styles as identified by the prefix "M" in the type number. If a motor driven model is ordered, be sure to prefix the part number with the desired travel time from 0 to maximum of 5, 15, 30, or 60 seconds.

The synchronous motor is designed for operation on 120 volts, 50/60 hertz single phase lines and draws approximately 0.3 amperes.

PART NUMBER		WIRING	INPUT		OUTPUT				SHAFT ROTATION FOR VOLTAGE INCREASE	TERMINAL CONNECTIONS (FOR INCREASING VOLTAGE) AS VIEWED FROM BASE END			SCHEMATIC (Pg 8 & 9)	NET WEIGHT LBS. MAX.		
MANUALLY OPERATED	MOTOR DRIVEN		VOLTS	HERTZ	VOLTS	CONSTANT CURRENT LOAD		CONSTANT IMPEDANCE LOAD		INPUT	JUMPER*	OUTPUT		MANUAL	MOTOR DRIVEN	
						MAX AMPS	MAX KVA	MAX AMPS								MAX KVA
1510 1510C 1510CT	M1510+ M1510C+ M1510CT+	Single Phase	120	50/60	0-120	15	1.80	20	2.40	CW	2-4	—	4-3	14	15 3/4	26
					0-140	15	2.10	—	—	CCW	2-4	—	2-3			
										CW	1-4	—	4-3			
										CCW	5-2	—	2-3			
1510-2 1510C-2 1510CT-2	M1510-2+ M1510C-2+ M1510CT-2+	Single Phase Series	240	50/60	0-240	15	3.60	20	4.80	CW	2-2	4-4	3-3	14 & 4	35 1/4	45 1/2
					0-280	15	4.20	—	—	CCW	4-4	2-2	3-3			
										CW	1-1	4-4	3-3			
										CCW	5-5	2-2	3-3			
		Three Phase Open Delta	120++	50/60	0-120	15	3.12	20	4.15	CW	2-4-2	4-4	3-4-3	14 & 5		
					0-140	15	3.64	—	—	CCW	4-2-4	2-2	3-2-3			
										CW	1-4-1	4-4	3-4-3			
										CCW	5-2-5	2-2	3-2-3			
1510-3 1510C-3 1510CT-3	M1510-3+ M1510C-3+ M1510CT-3+	Three Phase Wye	240++	50/60	0-240	15	6.22	20	8.30	CW	2-2-2	4-4-4	3-3-3	14 & 6	55 1/2	65 3/4
				60	0-280	15	7.26	—	—	CCW	4-4-4	2-2-2	3-3-3			
								CW	1-1-1	4-4-4	3-3-3					
								CCW	5-5-5	2-2-2	3-3-3					
3PN1510B	—	Single Phase	120	50/60	0-140	15‡	2.10	—	—	CW	LINE CORD & RECEPTACLE			3	18	—
3PN1510BA 3PN1510BV	—	Single Phase	120	50/60	0-140	15‡	2.10	—	—	CW	LINE CORD & RECEPTACLE			9	18	—
1520 1520C 1520CT	M1520+ M1520C+ M1520CT+	Single Phase	240	50/60	0-240	9.5	2.28	12	2.88	CW	2-4	—	4-3	15	19 1/4	29 1/2
					0-280	9.5	2.66	—	—	CCW	2-4	—	2-3			
								CW	1-4	—	4-3					
								CCW	5-2	—	2-3					
								CW	7-4	—	4-3					
								CCW	6-2	—	2-3					
1520-2 1520C-2 1520CT-2	M1520-2+ M1520C-2+ M1520CT-2+	Single Phase Series	480	50/60	0-480	9.5	4.56	12	5.76	CW	2-2	4-4	3-3	15 & 4	42 1/4	52 1/2
					0-560	9.5	5.32	—	—	CCW	4-4	2-2	3-3			
								CW	1-1	4-4	3-3					
								CCW	5-5	2-2	3-3					
								CW	7-7	4-4	3-3					
								CCW	6-6	2-2	3-3					
		Three Phase Open Delta	240++	50/60	0-240	9.5	3.95	12	5.0	CW	2-4-2	4-4	3-4-3	15 & 5		
					0-280	9.5	4.61	—	—	CCW	4-2-4	2-2	3-2-3			
								CW	1-4-1	4-4	3-4-3					
								CCW	5-2-5	2-2	3-2-3					
								CW	7-4-7	4-4	3-4-3					
								CCW	6-2-6	2-2	3-2-3					
1520-3 1520C-3 1520CT-3	M1520-3+ M1520C-3+ M1520CT-3+	Three Phase Wye	480++	50/60	0-480	9.5	7.90	12	10	CW	2-2-2	4-4-4	3-3-3	15 & 6	66	76 1/4
				60	0-560	9.5	9.21	—	—	CCW	4-4-4	2-2-2	3-3-3			
								CW	1-1-1	4-4-4	3-3-3					
								CCW	5-5-5	2-2-2	3-3-3					
								CW	7-7-7	4-4-4	3-3-3					
								CCW	6-6-6	2-2-2	3-3-3					
3PN1520B	—	Single Phase	240	50/60	0-280	9.5‡	2.66	—	—	CW	LINE CORD & RECEPTACLE			3	22	—

"A" suffix includes Ammeter, "V" suffix includes Voltmeter

+ Motor driven units use terminal connections for CCW increasing voltage, as viewed from the base end. See Fig 23 on page 9 for motor wiring.

• Jumper provided in the standard common position and should be moved or removed as required.

++ Line to line voltage

‡ Unit is fused for the constant current rating at the factory.

§ Maximum KVA at maximum output voltage and corresponding derated output current. Maximum KVA for lower voltages may be calculated from derating curve Figure B, page 6.

If ganged units are used in a system that ordinarily has a common neutral or ground between source and load, the neutral or ground must be connected to the common terminals of the variable transformer assembly. If the system has no neutral, the load must be balanced or the transformers will be damaged.

Maximum output current in output voltage range from 0 to 25% above line voltage. At higher output voltages, the output current must be reduced according to the derating curve, Figure B, page 6.

1500 Series

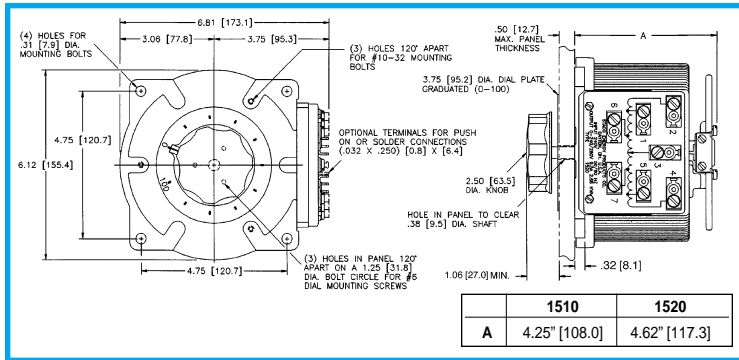

Manual Single, Uncased

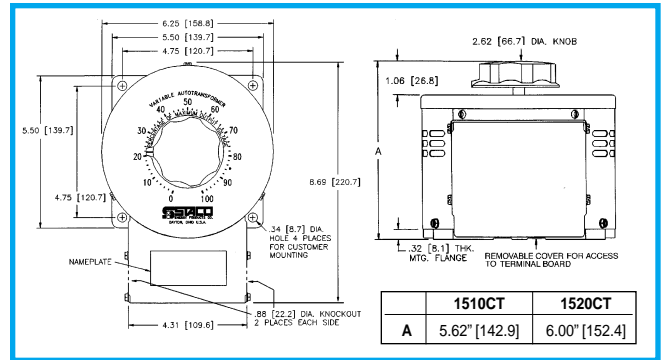

Manual Single, Cased

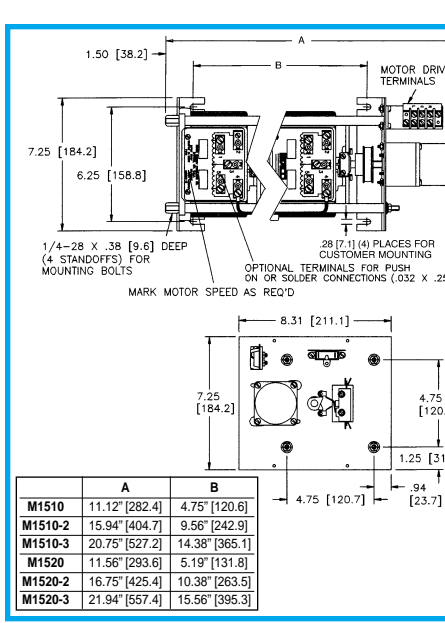
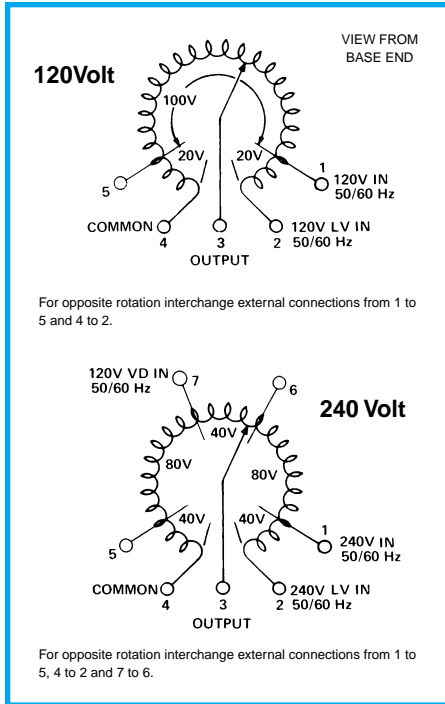

Motor-Driven Single, Two and Three-Ganged, Uncased

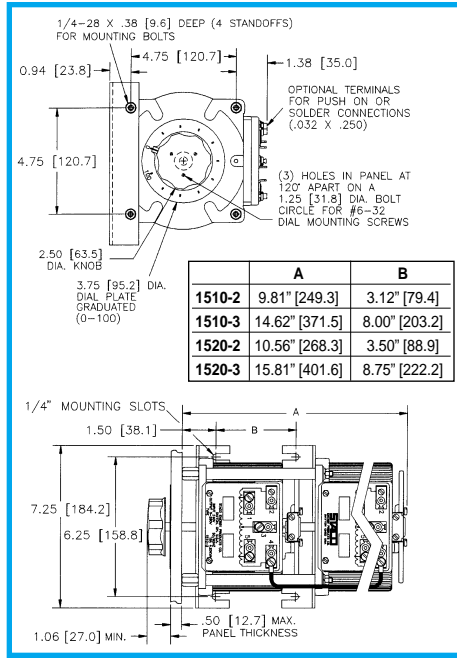

Motor-Driven Single, Two and Three-Ganged, Cased

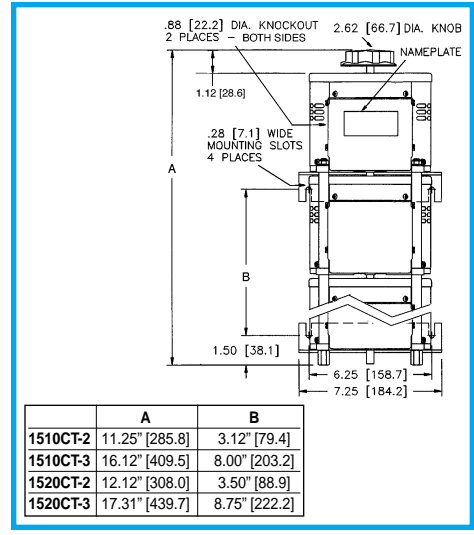

Manual Two- and Three-Ganged, Cased

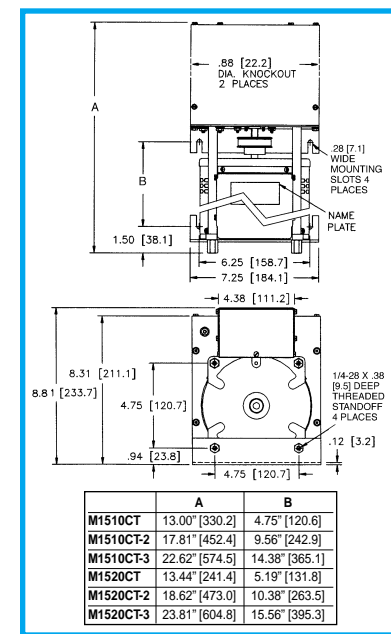

Motor-Driven Single, Two and Three-Ganged, Cased

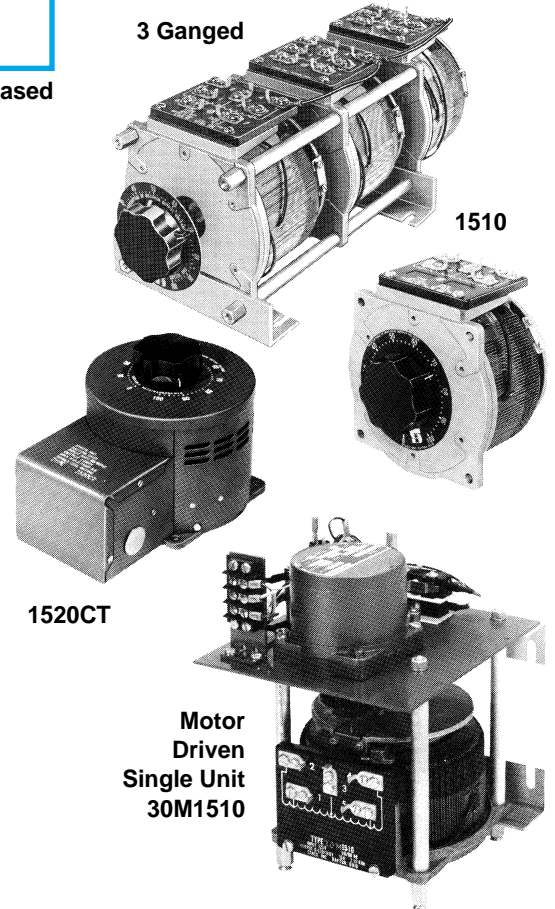

Компания «Life Electronics» занимается поставками электронных компонентов импортного и отечественного производства от производителей и со складов крупных дистрибьюторов Европы, Америки и Азии.

С конца 2013 года компания активно расширяет линейку поставок компонентов по направлению коаксиальный кабель, кварцевые генераторы и конденсаторы (керамические, пленочные, электролитические), за счёт заключения дистрибьюторских договоров

Мы предлагаем:

- Конкурентоспособные цены и скидки постоянным клиентам.
- Специальные условия для постоянных клиентов.
- Подбор аналогов.
- Поставку компонентов в любых объемах, удовлетворяющих вашим потребностям.
- Приемлемые сроки поставки, возможна ускоренная поставка.
- Доставку товара в любую точку России и стран СНГ.
- Комплексную поставку.
- Работу по проектам и поставку образцов.
- Формирование склада под заказчика.
- Сертификаты соответствия на поставляемую продукцию (по желанию клиента).
- Тестирование поставляемой продукции.
- Поставку компонентов, требующих военную и космическую приемку.
- Входной контроль качества.
- Наличие сертификата ISO.

В составе нашей компании организован Конструкторский отдел, призванный помогать разработчикам, и инженерам.

Конструкторский отдел помогает осуществить:

- Регистрацию проекта у производителя компонентов.
- Техническую поддержку проекта.
- Защиту от снятия компонента с производства.
- Оценку стоимости проекта по компонентам.
- Изготовление тестовой платы монтаж и пусконаладочные работы.



Тел: +7 (812) 336 43 04 (многоканальный)

Email: org@lifeelectronics.ru