

CM1214A

1 and 2-Channel PicoGuard® AC Signal ESD Protector

Product Description

The CM1214A *PicoGuard*® ESD protector is used to protect bipolar signal lines against electrostatic discharge (ESD). The CM1214A allows operation in high-speed environments with signals levels up to ± 5 V.

The CM1214A comes in two versions:

- The CM1214A-01SO is a single channel ESD protector and is available in a 3-lead SOT23-3 package.
- The CM1214A-02MR is a dual channel ESD protector and is available in an 8-lead MSOP-8 package.

The low sub-1 pF loading capacitance makes the CM1214A-01SO ideal for protecting high-speed interfaces including RF switches and amplifiers.

The CM1214A-02MR is ideal for dual high-speed signal pairs used in Gigabit Ethernet, ADSL, etc. The CM1214A-02MR can also be used for higher transmit voltage applications by connecting the two channels in series.

Features

- Single Channel ESD Protection for an AC Signal Up To ± 5 V for 0.25 W Transmit Power
- Connects Two Channels in Series for Signals Up To ± 10 V (1 W transmit power)
- ± 8 kV ESD Protection Per IEC 61000-4-2 Contact Discharge
- Sub-1pF Loading Capacitance
- Minimal Variation with Voltage and Temperature
- Each I/O Pin Can Withstand Over 1000 ESD Strikes*
- SOT23-3 and MSOP-8 Packages
- These Devices are Pb-Free and are RoHS Compliant

Applications

- RF Switch and Amplifier Protection
- RF Modules and RF IC Protection
- Wireless Handsets and WLAN
- High-Speed AC Signals for Gbit Ethernet, etc.



ON Semiconductor®

<http://onsemi.com>

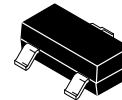

**SOT23-3
SO SUFFIX
CASE 318**

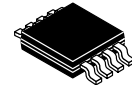

**MSOP-8
MR SUFFIX
CASE 846AD**

BLOCK DIAGRAM

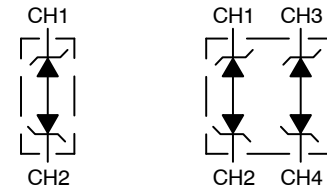

CM1214A-01SO

CM1214A-02MR

MARKING DIAGRAM

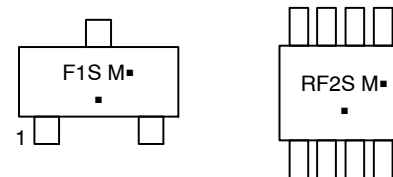

XXX = Specific Device Code
M = Date Code
▪ = Pb-Free Package
(Note: Microdot may be in either location)

ORDERING INFORMATION

| Device | Package | Shipping† |
|--------------|--------------------|------------------|
| CM1214A-01SO | SOT23 (Pb-Free) | 3000/Tape & Reel |
| CM1214A-02MR | MSOP (Pb-Free) | 4000/Tape & Reel |

†For information on tape and reel specifications, including part orientation and tape sizes, please refer to our Tape and Reel Packaging Specification Brochure, BRD8011/D.

*Standard test condition is IEC61000-4-2 level 4 test circuit with each pin subjected to ± 8 kV contact discharge for 1000 pulses. Discharges are timed at 1 second intervals and all 1000 strikes are completed in one continuous test run. The part is then subjected to standard production test to verify that all of the tested parameters are within spec after the 1000 strikes.

CM1214A

Table 1. PIN DESCRIPTIONS

| SOT23-3 Package | | |
|-----------------|------|-------------|
| Pin | Name | Description |
| 1 | CH1 | ESD Channel |
| 2 | CH2 | ESD Channel |
| 3 | N.C. | No connect |

| MSOP-8 Package | | |
|----------------|------|-------------|
| Pin | Name | Description |
| 1 | CH1 | ESD Channel |
| 2 | N.C. | No connect |
| 3 | N.C. | No connect |
| 4 | CH3 | ESD Channel |
| 5 | N.C. | No connect |
| 6 | CH4 | ESD Channel |
| 7 | CH2 | ESD Channel |
| 8 | N.C. | No connect |

PACKAGE / PINOUT DIAGRAMS

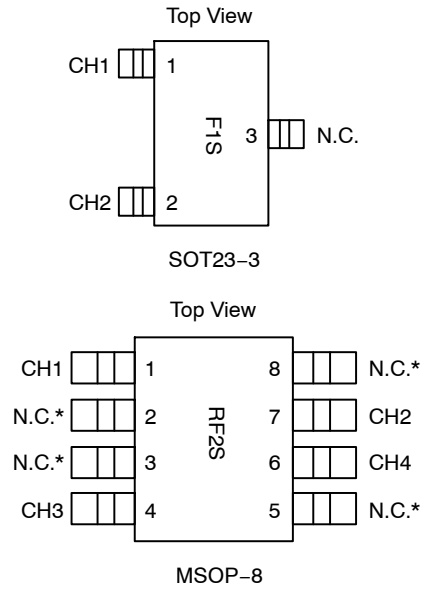

* All N.C. pins must be left floating (i.e., not connected to the PCB). See applications section for more information.

SPECIFICATIONS

Table 2. ABSOLUTE MAXIMUM RATINGS

| Parameter | Rating | Units |
|--|-------------|-------|
| DC Voltage between CH pins | 7 | V |
| Operating Temperature Range | -40 to +85 | °C |
| Storage Temperature Range | -65 to +150 | °C |
| Package Power Rating SOT23-3 Package (CM1214A-01SO) MSOP8 Package (CM1214A-02MR) | 225 400 | mW |

Stresses exceeding Maximum Ratings may damage the device. Maximum Ratings are stress ratings only. Functional operation above the Recommended Operating Conditions is not implied. Extended exposure to stresses above the Recommended Operating Conditions may affect device reliability.

Table 3. STANDARD OPERATING CONDITIONS

| Parameter | Rating | Units |
|-----------------------------|------------|-------|
| Operating Temperature Range | -40 to +85 | °C |

Table 4. ELECTRICAL OPERATING CHARACTERISTICS (Note 1)

| Symbol | Parameter | Conditions | Min | Typ | Max | Units |
|-------------------|---|--|-----|------|------|-------|
| V _{ST} | Standoff Voltage | I = 10 μA | | ±7 | | V |
| V _{ESD} | ESD Voltage Protection Peak discharge voltage between CH pins a) Contact discharge per IEC 61000-4-2 standard | (Notes 2 and 3) | ±8 | | | kV |
| I _{LEAK} | Channel Leakage Current | T _A = 25°C, 5.5 V between CH pins | | ±0.1 | ±1.0 | μA |
| R _{DYN} | Dynamic Resistance | T _A = 25°C, I _{PP} = 1 A, t _P = 8/20 μS Any I/O pin to Ground (Note 4) | | 1.36 | | Ω |

CM1214A

Table 4. ELECTRICAL OPERATING CHARACTERISTICS (Note 1)

| Symbol | Parameter | Conditions | Min | Typ | Max | Units |
|-----------------|---|--|-------------|-------------|------------|-------|
| V _{CL} | Channel Clamp Voltage | T _A = 25°C, I _{PP} = 1 A, t _P = 8/20 μS (Note 4) | | 11.3 | | V |
| C _{IN} | Channel Input Capacitance Voltage between CH pins = 0 V Voltage between CH pins = 5 V | Measured at 1 MHz between CH pins | 0.4 0.35 | 0.6 0.54 | 0.9 0.8 | pF |

1. All parameters specified at T_A = -40°C to +85°C unless otherwise noted.
2. Standard IEC 61000-4-2 with C_{Discharge} = 150 pF, R_{Discharge} = 330 Ω.
3. From CH pin with other CH pin grounded.
4. No Connect pins are left open for all tests.

PERFORMANCE INFORMATION

Typical Capacitance Characteristics vs. Voltage

CM1214A illustrates how the loading capacitance remains mainly flat across the voltage range from 0 V to 5 V, the voltage between CH pins.

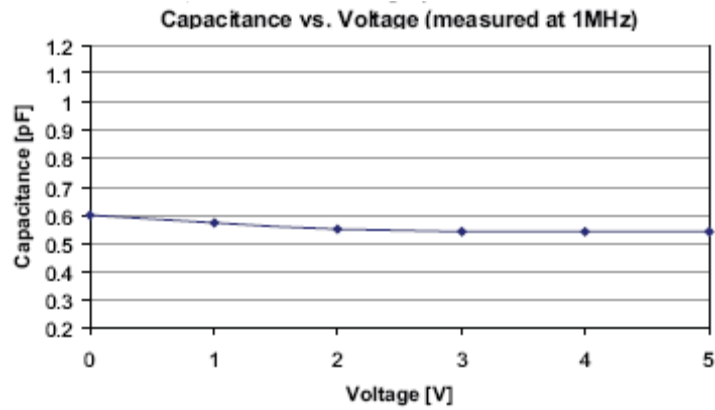

Figure 1. CM1214A Capacitance vs. Voltage

Typical Voltage Current (VI) Characteristics (low current)

CM1214A shows how the CM1214A experiences a symmetrical I/V curve, without any snapback or trigger voltage. It gradually starts to turn on at about 6 V and clamps above 7 V.

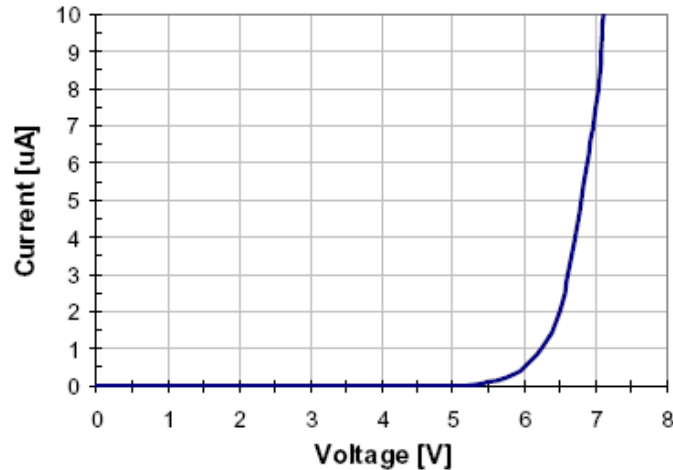

Figure 2. CM1214A VI Characteristics, Low Current

CM1214A

PERFORMANCE INFORMATION (Cont'd)

Typical Voltage–Current (VI) Characteristics (high current, pulse condition)

CM1214A shows how the CM1214A experiences a symmetrical I/V curve, without any snapback or trigger voltage. The curve shows only one polarity.

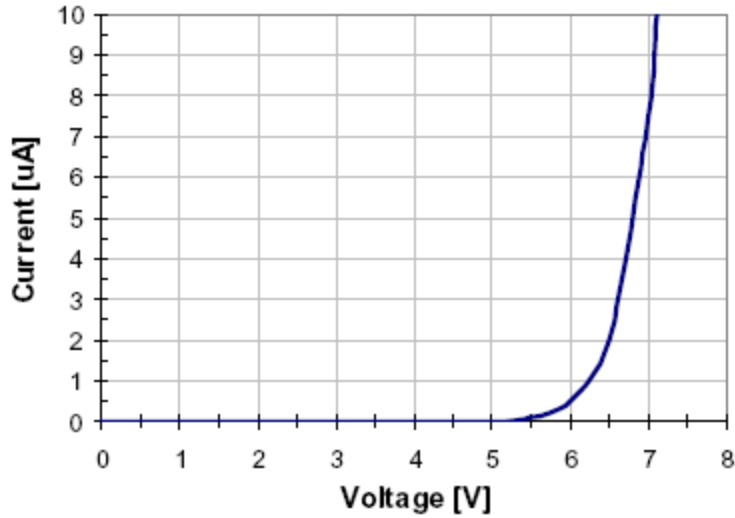

Figure 3. CM1214A VI Characteristics, High Current, Pulse (clamping) Condition

Typical Capacitance Characteristics vs. Temperature

CM1214A illustrates the loading capacitance for both 0 VDC and 1.65 VDC input across the -40 to 85°C temperature range.

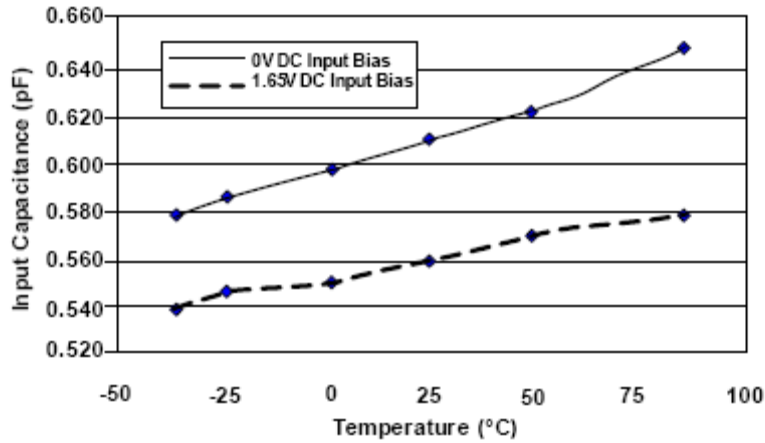

Figure 4. CM1214A Capacitance vs. Temperature

CM1214A

PERFORMANCE INFORMATION (Cont'd)

Typical Filter Performance (nominal conditions unless specified otherwise, 50 Ohm Environment)

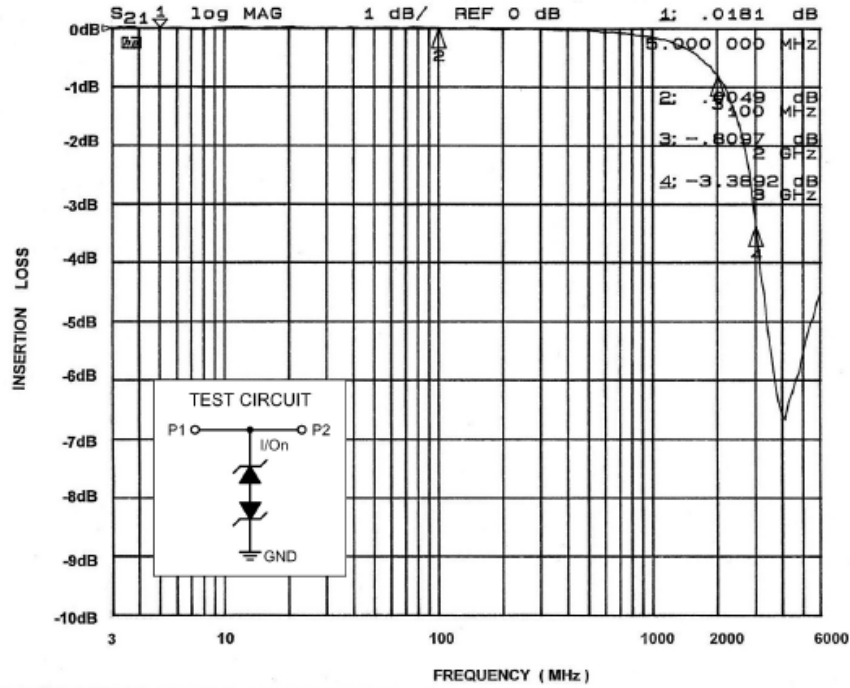

Figure 5. Insertion Loss vs. Frequency (0 V DC Bias)

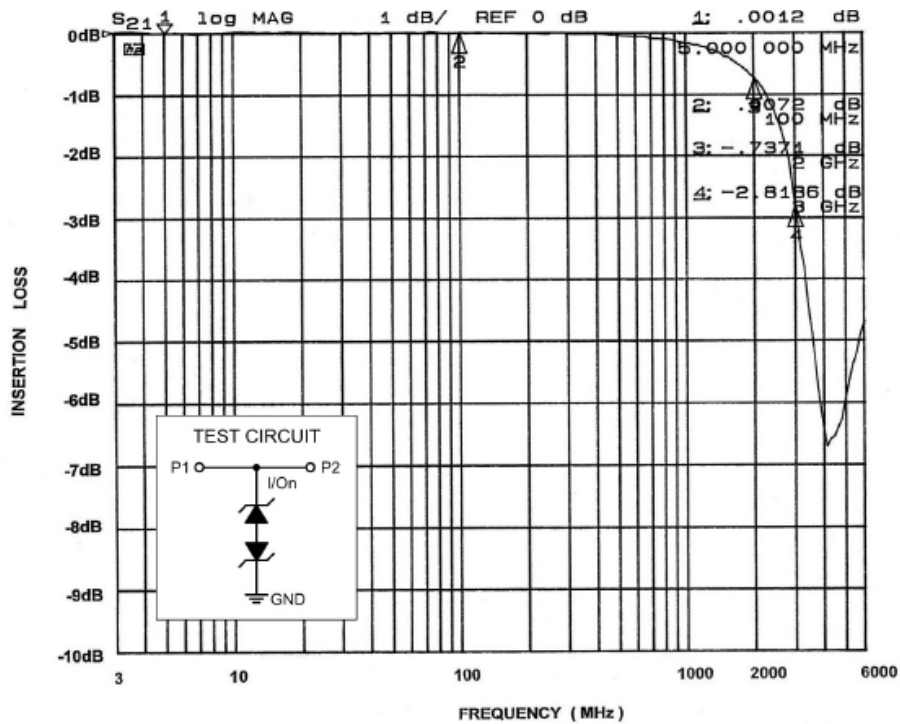

Figure 6. Insertion Loss vs. Frequency (2.5 V DC Bias)

CM1214A

APPLICATION INFORMATION

CM1214A-01SO

The CM1214A-01SO protects a single bipolar signal line often found in RF circuits. One I/O pin (pin 1 for example) is connected to the signal line for protection, and the other I/O pin is tied to GND. It is important to have a solid ground connection to reduce the clamping voltage. *Pin 3 of the 3-lead SOT23 must be left open (and not connected on the PCB).*

CM1214A-02MR

The CM1214A-02MR protects two bipolar lines, such as for Gbit Ethernet. The PCB traces underneath the package connect across to the corresponding pins (Pins 1, 4, 6 and 7). *Pins 2, 3, 5 and 8 of the MSOP-8 package must be left open (and not connected on the PCB).*

Any disturbance on the line above or below the standoff voltage is clamped.

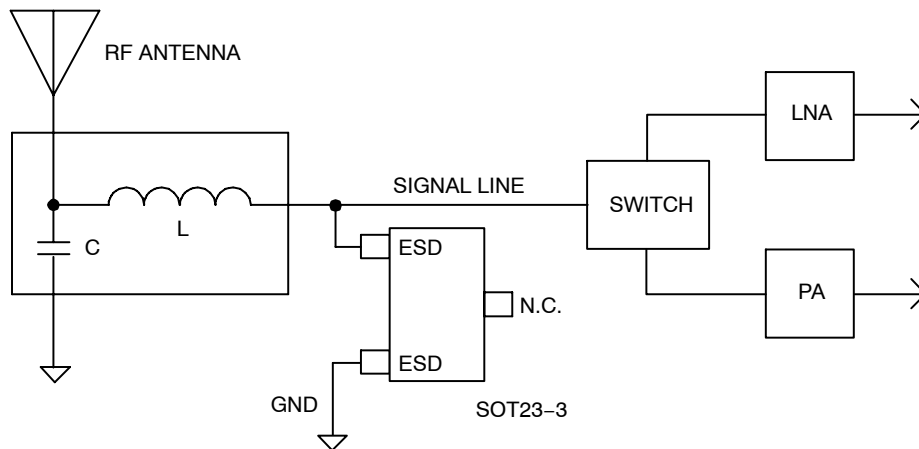

Figure 7. Typical Application - RF Switch and Amplifier Protection, CM1214A-01SO in 3-lead SOT23

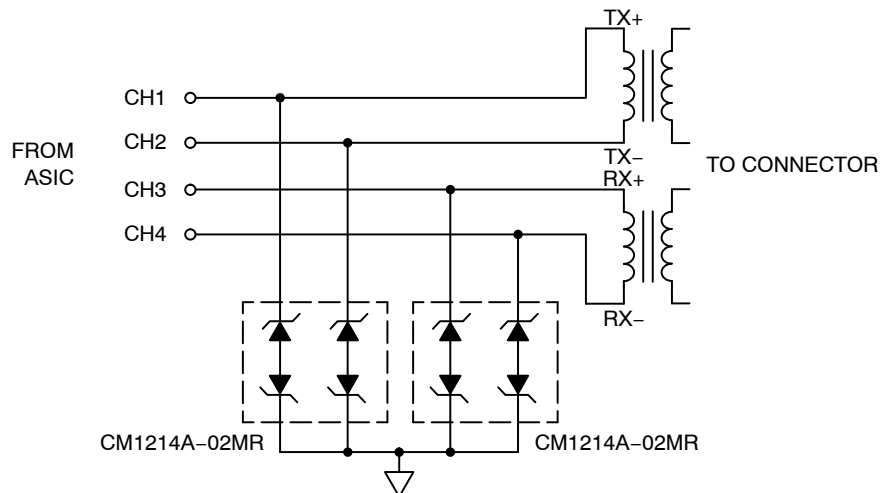
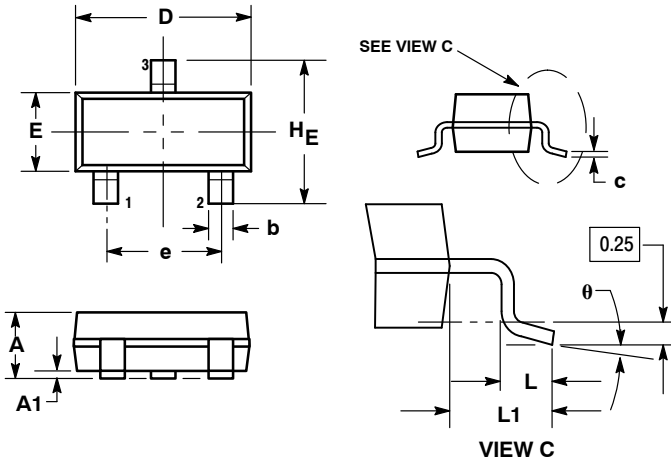

Figure 8. Typical Application - Ethernet Protection, CM1214A-02MR in 8-lead MSOP

CM1214A

PACKAGE DIMENSIONS

SOT-23 (TO-236)
CASE 318-08
ISSUE AP



NOTES:

1. DIMENSIONING AND TOLERANCING PER ANSI Y14.5M, 1982.
2. CONTROLLING DIMENSION: INCH.
3. MAXIMUM LEAD THICKNESS INCLUDES LEAD FINISH THICKNESS. MINIMUM LEAD THICKNESS IS THE MINIMUM THICKNESS OF BASE MATERIAL.
4. DIMENSIONS D AND E DO NOT INCLUDE MOLD FLASH, PROTRUSIONS, OR GATE BURRS.

| DIM | MILLIMETERS | | | INCHES | | |
|-----|-------------|------|------|--------|-------|-------|
| | MIN | NOM | MAX | MIN | NOM | MAX |
| A | 0.89 | 1.00 | 1.11 | 0.035 | 0.040 | 0.044 |
| A1 | 0.01 | 0.06 | 0.10 | 0.001 | 0.002 | 0.004 |
| b | 0.37 | 0.44 | 0.50 | 0.015 | 0.018 | 0.020 |
| c | 0.09 | 0.13 | 0.18 | 0.003 | 0.005 | 0.007 |
| D | 2.80 | 2.90 | 3.04 | 0.110 | 0.114 | 0.120 |
| E | 1.20 | 1.30 | 1.40 | 0.047 | 0.051 | 0.055 |
| e | 1.78 | 1.90 | 2.04 | 0.070 | 0.075 | 0.081 |
| L | 0.10 | 0.20 | 0.30 | 0.004 | 0.008 | 0.012 |
| L1 | 0.35 | 0.54 | 0.69 | 0.014 | 0.021 | 0.029 |
| HE | 2.10 | 2.40 | 2.64 | 0.083 | 0.094 | 0.104 |
| θ | 0° | --- | 10° | 0° | --- | 10° |

SOLDERING FOOTPRINT

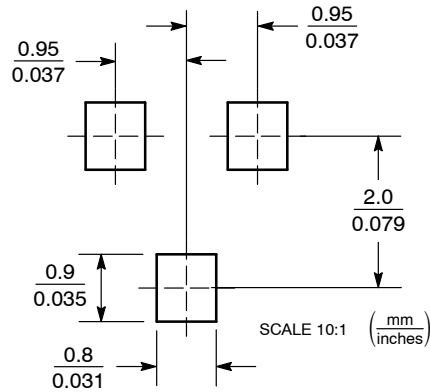

CM1214A

PACKAGE DIMENSIONS

MSOP 8, 3x3
CASE 846AD-01
ISSUE O

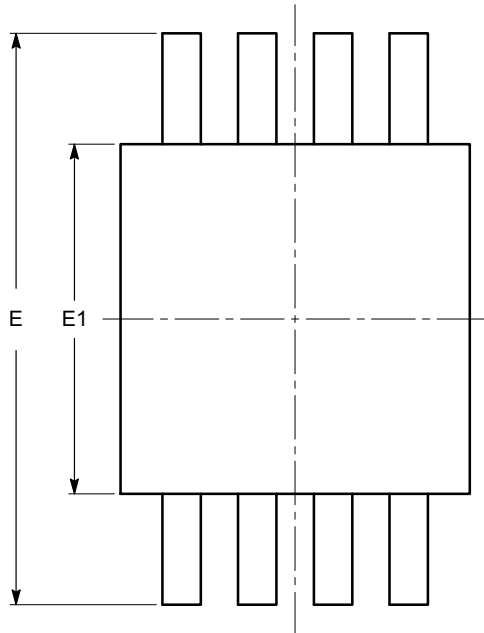

TOP VIEW

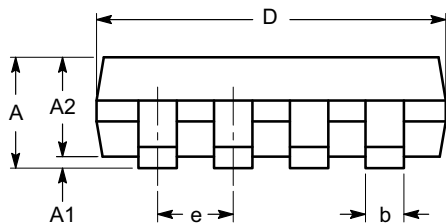

SIDE VIEW

| SYMBOL | MIN | NOM | MAX |
|----------|----------|------|------|
| A | | | 1.10 |
| A1 | 0.05 | 0.10 | 0.15 |
| A2 | 0.75 | 0.85 | 0.95 |
| b | 0.22 | | 0.38 |
| c | 0.13 | | 0.23 |
| D | 2.90 | 3.00 | 3.10 |
| E | 4.80 | 4.90 | 5.00 |
| E1 | 2.90 | 3.00 | 3.10 |
| e | 0.65 BSC | | |
| L | 0.40 | 0.60 | 0.80 |
| L1 | 0.95 REF | | |
| L2 | 0.25 BSC | | |
| θ | 0° | | 6° |

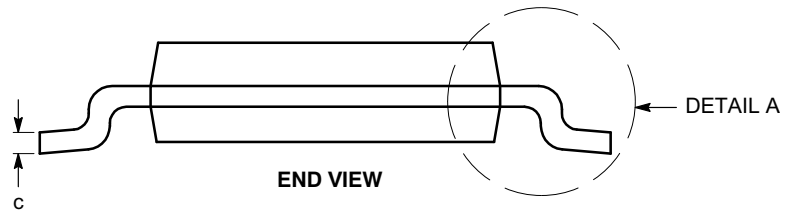

END VIEW

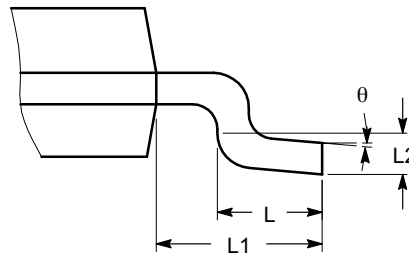

DETAIL A

Notes:

- (1) All dimensions are in millimeters. Angles in degrees.
- (2) Complies with JEDEC MO-187.

PicoGuard is a registered trademark of Semiconductor Components Industries, LLC (SCILLC).

ON Semiconductor and  are registered trademarks of Semiconductor Components Industries, LLC (SCILLC). SCILLC reserves the right to make changes without further notice to any products herein. SCILLC makes no warranty, representation or guarantee regarding the suitability of its products for any particular purpose, nor does SCILLC assume any liability arising out of the application or use of any product or circuit, and specifically disclaims any and all liability, including without limitation special, consequential or incidental damages. "Typical" parameters which may be provided in SCILLC data sheets and/or specifications can and do vary in different applications and actual performance may vary over time. All operating parameters, including "Typicals" must be validated for each customer application by customer's technical experts. SCILLC does not convey any license under its patent rights nor the rights of others. SCILLC products are not designed, intended, or authorized for use as components in systems intended for surgical implant into the body, or other applications intended to support or sustain life, or for any other application in which the failure of the SCILLC product could create a situation where personal injury or death may occur. Should Buyer purchase or use SCILLC products for any such unintended or unauthorized application, Buyer shall indemnify and hold SCILLC and its officers, employees, subsidiaries, affiliates, and distributors harmless against all claims, costs, damages, and expenses, and reasonable attorney fees arising out of, directly or indirectly, any claim of personal injury or death associated with such unintended or unauthorized use, even if such claim alleges that SCILLC was negligent regarding the design or manufacture of the part. SCILLC is an Equal Opportunity/Affirmative Action Employer. This literature is subject to all applicable copyright laws and is not for resale in any manner.

PUBLICATION ORDERING INFORMATION

LITERATURE FULFILLMENT:
Literature Distribution Center for ON Semiconductor
P.O. Box 5163, Denver, Colorado 80217 USA
Phone: 303-675-2175 or 800-344-3860 Toll Free USA/Canada
Fax: 303-675-2176 or 800-344-3867 Toll Free USA/Canada
Email: orderlit@onsemi.com

N. American Technical Support: 800-282-9855 Toll Free USA/Canada
Europe, Middle East and Africa Technical Support:
Phone: 421 33 790 2910
Japan Customer Focus Center
Phone: 81-3-5817-1050

ON Semiconductor Website: www.onsemi.com
Order Literature: <http://www.onsemi.com/orderlit>
For additional information, please contact your local Sales Representative

Компания «Life Electronics» занимается поставками электронных компонентов импортного и отечественного производства от производителей и со складов крупных дистрибьюторов Европы, Америки и Азии.

С конца 2013 года компания активно расширяет линейку поставок компонентов по направлению коаксиальный кабель, кварцевые генераторы и конденсаторы (керамические, пленочные, электролитические), за счёт заключения дистрибьюторских договоров

Мы предлагаем:

- Конкуренспособные цены и скидки постоянным клиентам.
- Специальные условия для постоянных клиентов.
- Подбор аналогов.
- Поставку компонентов в любых объемах, удовлетворяющих вашим потребностям.
- Приемлемые сроки поставки, возможна ускоренная поставка.
- Доставку товара в любую точку России и стран СНГ.
- Комплексную поставку.
- Работу по проектам и поставку образцов.
- Формирование склада под заказчика.
- Сертификаты соответствия на поставляемую продукцию (по желанию клиента).
- Тестирование поставляемой продукции.
- Поставку компонентов, требующих военную и космическую приемку.
- Входной контроль качества.
- Наличие сертификата ISO.

В составе нашей компании организован Конструкторский отдел, призванный помогать разработчикам, и инженерам.

Конструкторский отдел помогает осуществить:

- Регистрацию проекта у производителя компонентов.
- Техническую поддержку проекта.
- Защиту от снятия компонента с производства.
- Оценку стоимости проекта по компонентам.
- Изготовление тестовой платы монтаж и пусконаладочные работы.



Тел: +7 (812) 336 43 04 (многоканальный)

Email: org@lifeelectronics.ru