



# LOW-VOLTAGE 8:1 MULTIPLEXER/ DEMULTIPLEXER

IDT74CBTLV3251

## FEATURES:

- Functionally equivalent to QS3251
- $5\Omega$  bi-directional switch connection between two ports
- Isolation under power-off conditions
- Over-voltage tolerant
- Latch-up performance exceeds 100mA
- $V_{CC} = 2.3V - 3.6V$ , Normal Range
- ESD > 2000V per MIL-STD-883, Method 3015;  
> 200V using machine model (C = 200pF, R = 0)
- Available in QSOP and TSSOP packages

## DESCRIPTION:

The CBTLV3251 is a 1-of-8 high-speed multiplexer/demultiplexer. The low on-state resistance of the switch allows connections to be made with minimal propagation delay.

The select input (S0, S1, S2) controls the data flow. The multiplexer/demultiplexer switches are disabled when the output-enable ( $\overline{OE}$ ) input is high.

To ensure that the device is in high-impedance state during power up or power down,  $\overline{OE}$  should be tied to  $V_{CC}$  through a pullup resistor; the minimum value of the resistor is determined by the current-sinking capability of the driver.

## FUNCTIONAL BLOCK DIAGRAM



The IDT logo is a registered trademark of Integrated Device Technology, Inc.

INDUSTRIAL TEMPERATURE RANGE

DECEMBER 2014

PIN CONFIGURATION

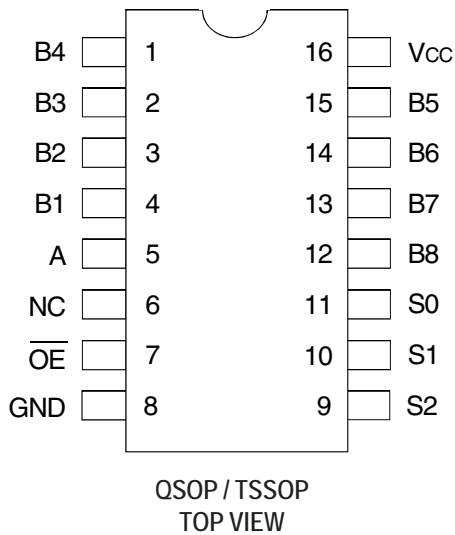

SIMPLIFIED SCHEMATIC, EACH SWITCH

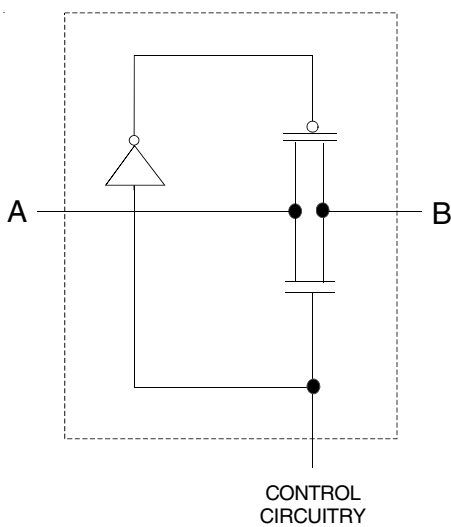

ABSOLUTE MAXIMUM RATINGS<sup>(1)</sup>

Symbol	Description	Max	Unit
V <sub>CC</sub>	Supply Voltage Range	-0.5 to +4.6	V
V <sub>I</sub>	Input Voltage Range	-0.5 to +4.6	V
	Continuous Channel Current	128	mA
I <sub>IK</sub>	Input Clamp Current, V <sub>I/O</sub> < 0	-50	mA
T <sub>STG</sub>	Storage Temperature	-65 to +150	°C

NOTE:

1. Stresses greater than those listed under ABSOLUTE MAXIMUM RATINGS may cause permanent damage to the device. This is a stress rating only and functional operation of the device at these or any other conditions above those indicated in the operational sections of this specification is not implied. Exposure to absolute maximum rating conditions for extended periods may affect reliability.

FUNCTION TABLE<sup>(1)</sup>

$\overline{OE}$	Inputs			Function
	S2	S1	S0	
L	L	L	L	A Port = B1 Port
L	L	L	H	A Port = B2 Port
L	L	H	L	A Port = B3 Port
L	L	H	H	A Port = B4 Port
L	H	L	L	A Port = B5 Port
L	H	L	H	A Port = B6 Port
L	H	H	L	A Port = B7 Port
L	H	H	H	A Port = B8 Port
H	X	X	X	Disconnect

NOTE:

1. H = HIGH Voltage Level  
L = LOW Voltage Level  
X = Don't Care

OPERATING CHARACTERISTICS, T<sub>A</sub> = 25°C<sup>(1)</sup>

Symbol	Parameter	Test Conditions	Min.	Max.	Unit
V <sub>CC</sub>	Supply Voltage		2.3	3.6	V
V <sub>IH</sub>	High-Level Control Input Voltage	V <sub>CC</sub> = 2.3V to 2.7V	1.7	—	V
		V <sub>CC</sub> = 2.7V to 3.6V	2	—	
V <sub>IL</sub>	Low-Level Control Input Voltage	V <sub>CC</sub> = 2.3V to 2.7V	—	0.7	V
		V <sub>CC</sub> = 2.7V to 3.6V	—	0.8	
T <sub>A</sub>	Operating Free-Air Temperature		-40	85	°C

NOTE:

1. All unused control inputs of the device must be held at V<sub>CC</sub> or GND to ensure proper device operation.

## DC ELECTRICAL CHARACTERISTICS OVER OPERATING RANGE

Following Conditions Apply Unless Otherwise Specified:

Operating Conditions:  $T_A = -40^{\circ}\text{C}$  to  $+85^{\circ}\text{C}$

Symbol	Parameter	Test Conditions		Min.	Typ. <sup>(1)</sup>	Max.	Unit
$V_{IK}$	Control Inputs, Data Inputs	$V_{CC} = 3V$ , $I_I = -18\text{mA}$		—	—	-1.2	V
$I_I$	Control Inputs	$V_{CC} = 3.6V$ , $V_I = V_{CC}$ or GND		—	—	$\pm 1$	$\mu\text{A}$
$I_{OZ}$	Data I/O	$V_{CC} = 3.6V$ , $V_O = 0$ or $3.6V$ , switch disabled		—	—	5	$\mu\text{A}$
$I_{OFF}$		$V_{CC} = 0$ , $V_I$ or $V_O = 0$ to $3.6V$		—	—	50	$\mu\text{A}$
$I_{CC}$		$V_{CC} = 3.6V$ , $I_O = 0$ , $V_I = V_{CC}$ or GND		—	—	10	$\mu\text{A}$
$\Delta I_{CC}^{(2)}$	Control Inputs	$V_{CC} = 3.6V$ , one input at $3V$ , other inputs at $V_{CC}$ or GND		—	—	300	$\mu\text{A}$
$C_I$	Control Inputs	$V_I = 3V$ or $0$		—	4	—	pF
$C_{IO(OFF)}$	A Port	$V_O = 3V$ or $0$ , $\overline{OE} = V_{CC} = 3.3V$		—	40.5	—	pF
	B Port			—	6	—	
$R_{ON}^{(3)}$	$V_{CC} = 2.3V$ Typ. at $V_{CC} = 2.5V$	$V_I = 0$	$I_O = 64\text{mA}$	—	5	8	$\Omega$
			$I_O = 24\text{mA}$	—	5	8	
		$V_I = 1.7V$	$I_O = 15\text{mA}$	—	27	40	
	$V_{CC} = 3V$	$V_I = 0$	$I_O = 64\text{mA}$	—	5	7	
			$I_O = 24\text{mA}$	—	5	7	
		$V_I = 2.4V$	$I_O = 15\text{mA}$	—	10	15	

### NOTES:

- Typical values are at  $V_{CC} = 3.3V$ ,  $+25^{\circ}\text{C}$  ambient.
- The increase in supply current is attributable to each current that is at the specified voltage level rather than  $V_{CC}$  or GND.
- This is measured by the voltage drop between the A and B terminals at the indicated current through the switch. On-state resistance is determined by the lower of the voltages of the two (A or B) terminals.

## SWITCHING CHARACTERISTICS

Symbol	Parameter	$V_{CC} = 2.5V \pm 0.2V$		$V_{CC} = 3.3V \pm 0.3V$		Unit
		Min.	Max.	Min.	Max.	
$t_{PD}^{(1)}$	Propagation Delay A to B or B to A	—	0.15	—	0.25	ns
$t_{SEL}$	Select Time S to A or B	1	4.8	1	4.5	ns
$t_{EN}$	Enable Time S to B	1	4.8	1	4.5	ns
$t_{DIS}$	Disable Time S to B	1	5.1	1	5.3	ns
$t_{EN}$	Output Enable Time $\overline{OE}$ to A or B	1	5	1	4.8	ns
$t_{DIS}$	Output Disable Time $\overline{OE}$ to A or B	1	5.5	1	6	ns

### NOTE:

- The propagation delay is the calculated RC time constant of the typical on-state resistance of the switch and the specified load capacitance driven by an ideal voltage source (zero output impedance).

TEST CIRCUITS AND WAVEFORMS

TEST CONDITIONS

Symbol	V <sub>CC</sub> <sup>(1)</sup> = 3.3V±0.3V	V <sub>CC</sub> <sup>(2)</sup> = 2.5V±0.2V	Unit
V <sub>LOAD</sub>	6	2 x V <sub>CC</sub>	V
V <sub>IH</sub>	3	V <sub>CC</sub>	V
V <sub>T</sub>	1.5	V <sub>CC</sub> / 2	V
V <sub>LZ</sub>	300	150	mV
V <sub>HZ</sub>	300	150	mV
C <sub>L</sub>	50	30	pF



Test Circuits for All Outputs

DEFINITIONS:

C<sub>L</sub> = Load capacitance: includes jig and probe capacitance.  
R<sub>T</sub> = Termination resistance: should be equal to Z<sub>OUT</sub> of the Pulse Generator.

NOTES:

1. Pulse Generator for All Pulses: Rate ≤ 10MHz; t<sub>r</sub> ≤ 2.5ns; t<sub>r</sub> ≤ 2.5ns.
2. Pulse Generator for All Pulses: Rate ≤ 10MHz; t<sub>r</sub> ≤ 2ns; t<sub>r</sub> ≤ 2.5ns.

SWITCH POSITION

Test	Switch
t <sub>PLZ</sub> /t <sub>PZL</sub>	V <sub>LOAD</sub>
t <sub>PHZ</sub> /t <sub>PZH</sub>	GND
t <sub>SEL</sub>	Open
t <sub>PD</sub>	Open



Propagation Delay



Enable and Disable Times

## ORDERING INFORMATION

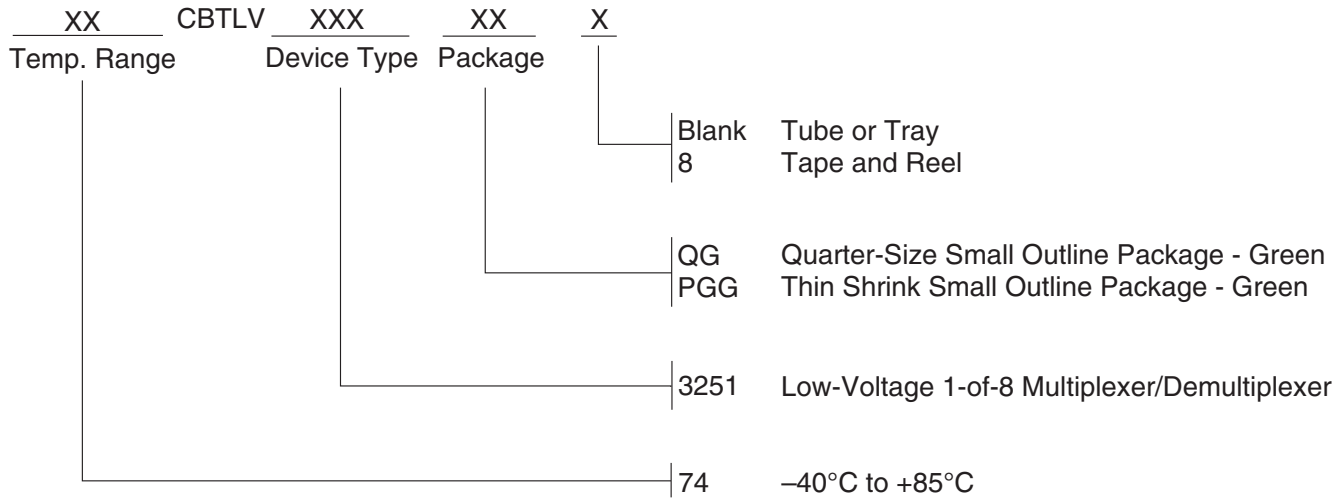

## Datasheet Document History

12/18/2014 Pg. 5 Updated the ordering information by removing non RoHS part and adding Tape and Reel information.



**CORPORATE HEADQUARTERS**  
6024 Silver Creek Valley Road  
San Jose, CA 95138

**for SALES:**  
800-345-7015 or 408-284-8200  
fax: 408-284-2775  
www.idt.com

**for Tech Support:**  
logichelp@idt.com

Компания «Life Electronics» занимается поставками электронных компонентов импортного и отечественного производства от производителей и со складов крупных дистрибьюторов Европы, Америки и Азии.

С конца 2013 года компания активно расширяет линейку поставок компонентов по направлению коаксиальный кабель, кварцевые генераторы и конденсаторы (керамические, пленочные, электролитические), за счёт заключения дистрибьюторских договоров

Мы предлагаем:

- Конкурентоспособные цены и скидки постоянным клиентам.
- Специальные условия для постоянных клиентов.
- Подбор аналогов.
- Поставку компонентов в любых объемах, удовлетворяющих вашим потребностям.
- Приемлемые сроки поставки, возможна ускоренная поставка.
- Доставку товара в любую точку России и стран СНГ.
- Комплексную поставку.
- Работу по проектам и поставку образцов.
- Формирование склада под заказчика.
- Сертификаты соответствия на поставляемую продукцию (по желанию клиента).
- Тестирование поставляемой продукции.
- Поставку компонентов, требующих военную и космическую приемку.
- Входной контроль качества.
- Наличие сертификата ISO.

В составе нашей компании организован Конструкторский отдел, призванный помогать разработчикам, и инженерам.

Конструкторский отдел помогает осуществить:

- Регистрацию проекта у производителя компонентов.
- Техническую поддержку проекта.
- Защиту от снятия компонента с производства.
- Оценку стоимости проекта по компонентам.
- Изготовление тестовой платы монтаж и пусконаладочные работы.



Тел: +7 (812) 336 43 04 (многоканальный)  
Email: [org@lifeelectronics.ru](mailto:org@lifeelectronics.ru)