



User Manual – AS5161 / AS5162 Adapterboard

# **AS5161-EK-AB / AS5162-EK-AB**

## **12 BIT Magnetic Angle Position Sensor**



# Table of Contents

- 1. General Description ..... 2
- 2. Package and Board Description ..... 3
- 3. AS5161/ AS5162 and adapter board pin out ..... 5
- 4. Operation case ..... 6
- 5. Programming the AS5161 / AS5162 ..... 6
- 6. AS5161 /AS5162 adapter board hardware ..... 7
- 7. Ordering Information..... 8
- Copyright..... 9
- Disclaimer ..... 9

## 1. General Description

This document describes the features and operation of the AS5161 / AS5162 Adapterboard.

The AS5161 / AS5162 is a contactless magnetic angle position sensor for accurate angular measurement over a full turn of 360°. A sub range can be programmed to achieve the best resolution for the application. It is a system-on-chip, combining integrated Hall elements, analog front end, digital signal processing and best in class automotive protection features in a single device.

To measure the angle, only a simple two-pole magnet, rotating over the center of the chip, is required. The magnet may be placed above or below the IC.

The absolute angle measurement provides instant indication of the magnet's angular position with a resolution of  $0.022^\circ = 16384$  positions per revolution. According to this resolution the adjustment of the application specific mechanical positions are possible. The angular output data is available over a 12 bit ratiometric analog output.

The AS5161 / AS5162 operates at a supply voltage of 5V and the supply and output pins are protected against overvoltage up to +20V. In addition the supply pins are protected against reverse polarity up to -20V

## 2. Package and Board Description

### Adapterboard Kit Contents

The demo kit includes following items listed below in Table 1.

Table 1:  
Adapter Kit Contents

Pos	Item	Comment
1	AS5161/AS5162 Adapterboard	Board + AS5161 or AS5162
2	Diametrial Magnets	

### Board Description

The AS5161 / AS5162 adapter board is a simple circuit allowing test and evaluation the rotary encoder quickly without building a test fixture or PCB. The PCB requires only a 3-wire connection: 5V power supply, GND and the output connection . Only pin 1, 3, 5, and 7 of JP1 are connected. Capacitor C2 (1uF) is buffering the LDO output VDD3; C3 (1uF) is placed between VDD and GND.

Resistor R1 and R2 as well as the capacitor C4 and C5 are optional, for using different filter options during the Evaluation phase..

Figure 1  
Adapterboard front view

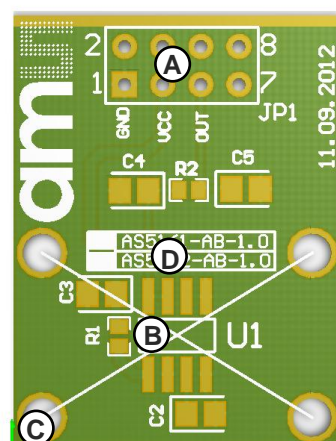

- (A) JP1 Connector  
( GND,VCC,OUT)
- (B) AS5161 / AS5162 sensor
- (C) 4 x 2.6 mm mounting holes
- (D) Marking for AS5161 or AS5162 AB Board

## Mounting the AS5161 / AS5162 adapter board

Figure 2  
Adapter board with mechanical components

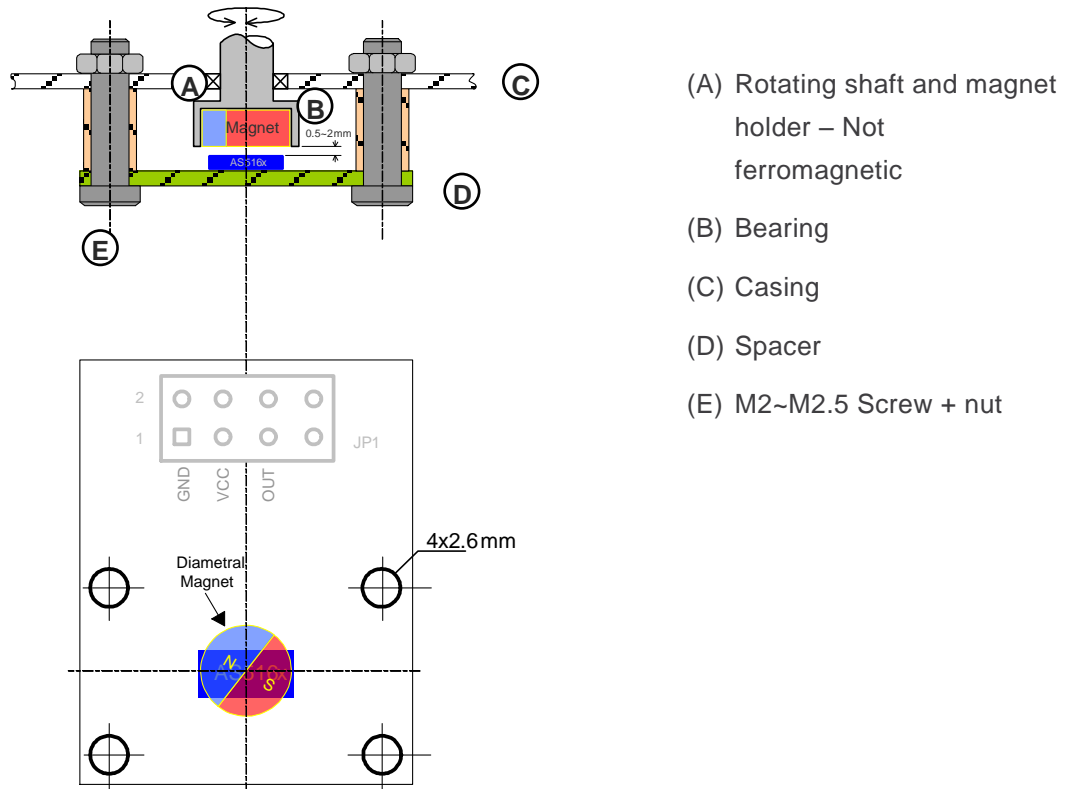

A diametric magnet must be placed over or under the AS5161 / AS5162 Adapterboard, and should be placed centered in x and y direction. Tolerance of 0.5mm

The airgap between the magnet and the encoder casing should be maintained in the range of 0.5mm~2mm ( magnet related).

The magnet holder must be not ferromagnetic. e.g copper, aluminium, stainless steel.

### 3. AS5161/ AS5162 and adapter board pin out

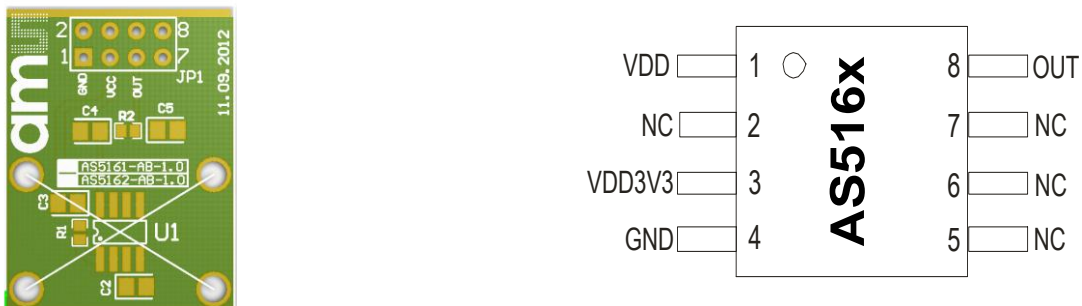

Figure 3 AS5161/AS5162 adapterboard connectors and sensor pinout

Table 2:  
Pin Out

Pin# Board	Pin# AS5161/62	Symbol Board	Type	Description
JP1 - 1	2,4,5	GND	S	Supply ground
JP1 - 2				Not connected
JP1 - 3	1	VCC	S	Positive supply pin (overvoltage protected)
JP1 - 4				Not connected
JP1 - 5	15	OUT	DIO/AIO	Output and interface pin. Provides PWM Output on the AS5161 and Analogoutput on the AS5162 .It is as well used for programming UART interface
JP1 - 6				Not connected
JP1 - 7				Not connected
JP1 - 8				Not connected

## 4. Operation case

Figure 4 Operation Case example pull up.

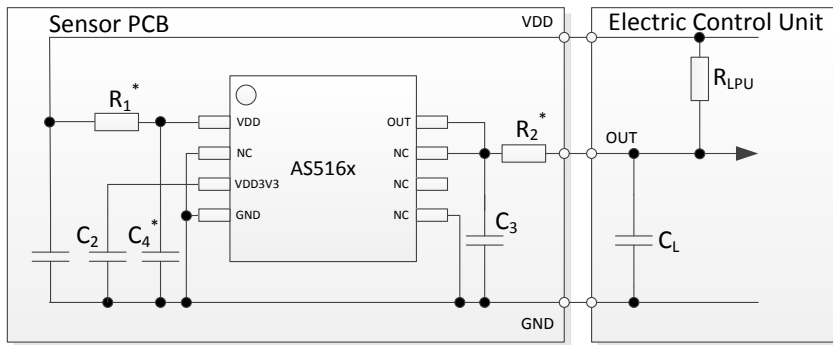

The OUT pin (JP1 – 5) is used as output as well as programming interface. After the first power up, the AS5161 or the AS5162 is in communication mode. During this mode different settings are possible to program. via UART . After the fusing of the internal OTP ( one time programmable ) block, the AS5161 provides a pulse width modulated output (PWM) and the AS5162 provides an analog output,

Figure 5 shows the recommended schematic for AS5161 and AS5162(pull up solution) in the application. All components marked with (\*) are optional and can be used to further increase the EMC. For further information, please refer to datasheet.

## 5. Programming the AS5161 / AS5162

For programming of the AS5161 / AS5162 only 3 connections (VCC, GND and OUT) are necessary. The AS5161 /AS5162 programming is a one-time-programming (OTP) method, based on polysilicon fuses. The advantage of this method is that no additional programming voltage is needed. The internal LDO provides the current for programming.

The AS5161 / AS5162 uses a standard UART interface with an address byte and two data byte.

For programming the AS5161 / AS5162 there is a DemoSoftware ( Executable Labview) and an easy UART-Interfaceboard available.

## 6. AS5161 /AS5162 adapter board hardware

### AS5161-EK-AB and AS5162-EK-AB Schematic

Figure 5

#### Adapterboard Schematic

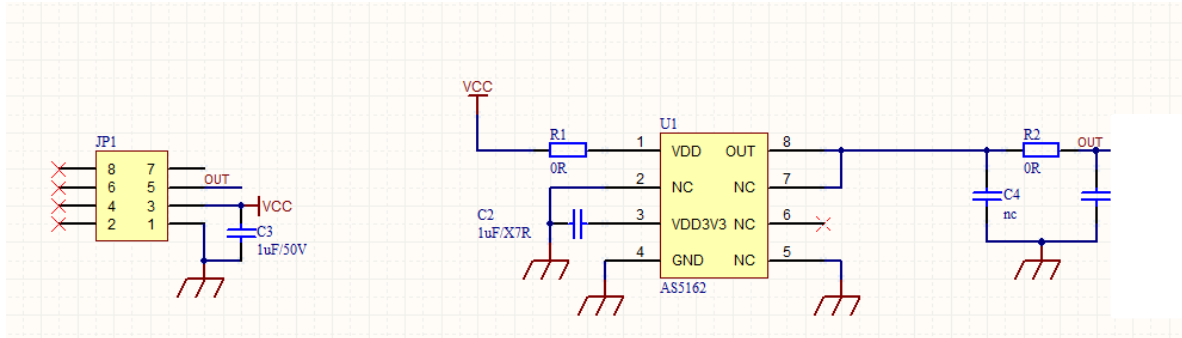

### AS5161-EK-AB and AS5162-EK-AB PCB layout

Figure 6:

#### Adapterboard Layout

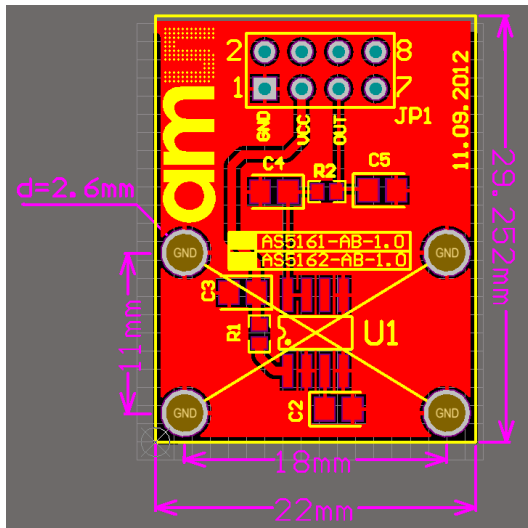



## 7. Ordering Information

Table 3:  
Ordering Information

Ordering Code	Description	comments
AS5161-EK-AB	AS5161 Adapterboard	3 diametric magnets
AS5162-EK-AB	AS5162 Adapterboard	3 diametric magnets

## Copyright

Copyright © 1997-2012, ams AG, Tobelbader Strasse 30, 8141 Unterpemstaetten, Austria-Europe. Trademarks Registered ®. All rights reserved. The material herein may not be reproduced, adapted, merged, translated, stored, or used without the prior written consent of the copyright owner.

All products and companies mentioned are trademarks or registered trademarks of their respective companies.

## Disclaimer

Devices sold by ams AG are covered by the warranty and patent indemnification provisions appearing in its Term of Sale. ams AG makes no warranty, express, statutory, implied, or by description regarding the information set forth herein or regarding the freedom of the described devices from patent infringement. ams AG reserves the right to change specifications and prices at any time and without notice. Therefore, prior to designing this product into a system, it is necessary to check with ams AG for current information.

This product is intended for use in normal commercial applications. Applications requiring extended temperature range, unusual environmental requirements, or high reliability applications, such as military, medical life-support or lifesustaining equipment are specifically not recommended without additional processing by ams AG for each application. For shipments of less than 100 parts the manufacturing flow might show deviations from the standard production flow, such as test flow or test location.

The information furnished here by ams AG is believed to be correct and accurate. However, ams AG shall not be liable to recipient or any third party for any damages, including but not limited to personal injury, property damage, loss of profits, loss of use, interruption of business or indirect, special, incidental or consequential damages, of any kind, in connection with or arising out of the furnishing, performance or use of the technical data herein. No obligation or liability to recipient or any third party shall arise or flow out of ams AG rendering of technical or other services.

## Contact Information

### Headquarters

ams AG  
Tobelbader Strasse 30  
8141 Unterpemstaetten  
Austria  
T. +43 (0) 3136 500 0  
For Sales Offices, Distributors and Representatives, please visit:  
<http://www.ams.com/contact>

Компания «Life Electronics» занимается поставками электронных компонентов импортного и отечественного производства от производителей и со складов крупных дистрибьюторов Европы, Америки и Азии.

С конца 2013 года компания активно расширяет линейку поставок компонентов по направлению коаксиальный кабель, кварцевые генераторы и конденсаторы (керамические, пленочные, электролитические), за счёт заключения дистрибьюторских договоров

Мы предлагаем:

- Конкурентоспособные цены и скидки постоянным клиентам.
- Специальные условия для постоянных клиентов.
- Подбор аналогов.
- Поставку компонентов в любых объемах, удовлетворяющих вашим потребностям.
- Приемлемые сроки поставки, возможна ускоренная поставка.
- Доставку товара в любую точку России и стран СНГ.
- Комплексную поставку.
- Работу по проектам и поставку образцов.
- Формирование склада под заказчика.
- Сертификаты соответствия на поставляемую продукцию (по желанию клиента).
- Тестирование поставляемой продукции.
- Поставку компонентов, требующих военную и космическую приемку.
- Входной контроль качества.
- Наличие сертификата ISO.

В составе нашей компании организован Конструкторский отдел, призванный помогать разработчикам, и инженерам.

Конструкторский отдел помогает осуществить:

- Регистрацию проекта у производителя компонентов.
- Техническую поддержку проекта.
- Защиту от снятия компонента с производства.
- Оценку стоимости проекта по компонентам.
- Изготовление тестовой платы монтаж и пусконаладочные работы.



Тел: +7 (812) 336 43 04 (многоканальный)  
Email: [org@lifeelectronics.ru](mailto:org@lifeelectronics.ru)