



HMI Solution & Graphic Products



Specifications

Intelligent Display 7"

Resistive Touchscreen

Contents

CHAPTER 1: VERSIONS HISTORY	2
CHAPTER 2: GENERAL DESCRIPTION	3
CHAPTER 3: SPECIFICATION OF THE INTELLIGENT DISPLAY	3
MECHANICAL AND ENVIRONMENTAL CHARACTERISTICS	3
FUNCTIONAL CHARACTERISTICS	3
CHAPTER 4: DESCRIPTION OF CONNECTIONS	4
CONNECTOR N°1: USB HOST	4
CONNECTOR N°2: RS232 TTL OR CAN	5
CONNECTOR N°3: RS232 PC	5
CHAPTER 5: MECHANICAL DESCRIPTION	6
CHAPTER 6: CLAIRITEC'S CONTACT	7

Chapter 1: Versions history

Reference	Modifications	Date
DOC-20140414-1A-UK	Creation	04/04/2014
DOC-20140414-1B-UK	Add storage temperature	29/04/2014
DOC-20140414-1C-UK	Add horizontal / vertical flip. Fix consumption.	23/06/2014
DOC-20140414-1D-UK	Add inrush current and update power supply	25/08/2017
DOC-20140414-1E-UK	Company and contact information	27/08/2017

Chapter 2: General description

The Intelligent Display is a "Plug & Play" graphic display module developed & produced in France.

It consists of a TFT-LCD 7 "WVGA (800 x 480 pixels) touchscreen display with integrated HMI board from CLAIRITEC and a metal protective cover.

The Intelligent Display is EMC compliant and withstands a temperature range from -20°C to +70°C.

It can fit easily into electronic equipment thanks to its 4 fixing points.

Chapter 3: Specification of the intelligent display

MECHANICAL AND ENVIRONMENTAL CHARACTERISTICS

Item	Specifications
Size	7" Diagonal
Resolution	800 x RGB x 480 dots (WVGA)
Viewing direction	6 o'clock
Viewing area	155.3 (W) x 94.3 (H) mm
Horizontal / Vertical flip	Not available
Backlight	White LED
Brightness	400 cd/m ²
Viewing angle (typ.)	120° Vertical / 140° Horizontal
Touch screen	4-wire resistive / 1 million touch times by finger
Operating temperature	-20°C ~ +70°C
Storage temperature	-30°C ~ +80°C
EMC compliant	NF-EN55022 class B (Frequency range 150 kHz to 2 GHz) NF-EN61000-4-2 (8 kV contact discharge / 15 kV air discharge) NF-EN61000-4-3 (Frequency range : 30 MHz to 1 GHz – 10 V/m)
Outline dimension	186.8 (W) x 104.4 (H) x 17.7 (D) mm
Weight	400 g. for stainless steel protective cover

FUNCTIONAL CHARACTERISTICS

Item	Specifications
Color LCD Management	65535K color / TFT transmissive active matrix
Touchscreen Management	Advanced clicking area processing
Graphic Engine	Advanced display algorithms
Graphic pages Management	Two pages dynamically managed
Storage Memory	32 Mb
Graphical Layout Management	GraphConverter®3 software tool enables you to build your HMI's graphic library and upload it in the board flash memory
Communication Bus	RS232 serial (9600bds to 355Kbds) CAN 2.0B (100Kbds to 500Kbds) USB
Power Supply	5V (+/-2%) or 6-36V +/- 5%
Inrush current (5V version only)	1.5A / 500us
Maximum Consumption	4.5W

Chapter 4: Description of connections

The Clairitec Intelligent Display has three communication connectors as shown in the photo below:

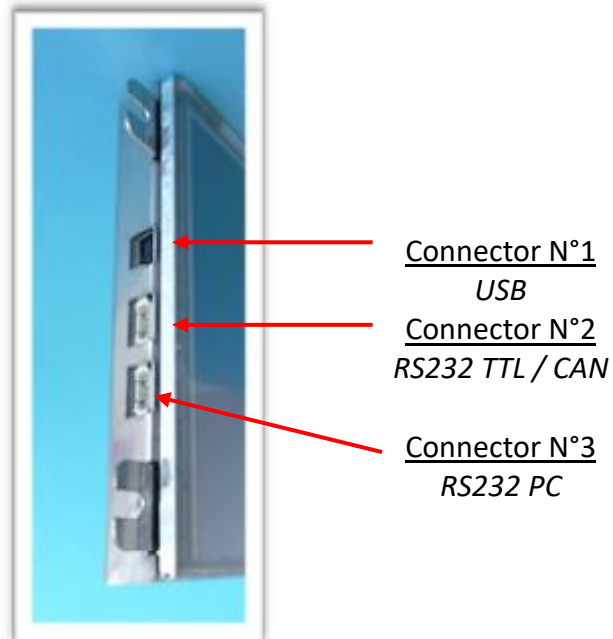

CONNECTOR N°1: USB

This connector allows you to update firmware, and the graphics chart via a computer or a USB key. Thanks to its transfer via USB, the loading time is decreased. Requires a standard adapter USB -> mini USB, available in the starter kit.

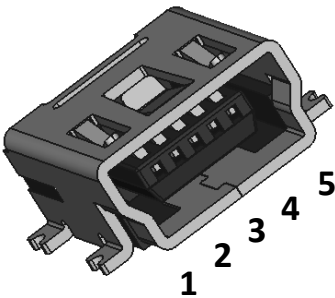

Pin number	I/O	Description
1	Power	Power Supply +5V / 500mA max
2	I/O	USB -
3	I/O	USB +
4	-	Reserved
5	Power	GND

CONNECTOR N°2: RS232 TTL OR CAN

Connection Interface for serial communication EIA / RS232E or CAN2.0B between the Clairitec HMI board and your application board.

- Update the firmware with the RS232 SpiderGraph protocol,
- Update your graphic chart with the RS232 SpiderGraph protocol,
- Send and receive commands with the RS232 or Can2.0B SpiderGraph protocol.

PCB base reference: Würth: 653105131822
Molex: 53261-0571

Matting model: Würth: 653005113322
Molex: 51021-0500

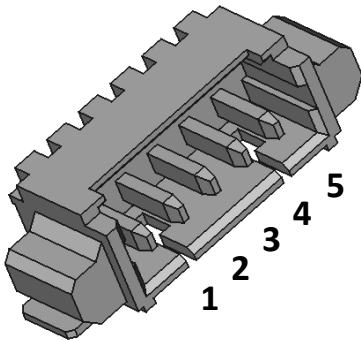

Pin number	I/O	Description
1	Power	Power Supply +12V
2	Power	GND
3	I/O	RS232 TTL TX or CAN H
4	I/O	RS232 TTL RX or CAN L
5	Power	GND

CONNECTOR N°3: RS232 PC

Connection Interface for serial communication EIA / RS232E between the Clairitec HMI board and your application board.

- Update the firmware with the RS232 SpiderGraph protocol,
- Update your graphic chart with the RS232 SpiderGraph protocol,
- Send and receive commands with the RS232 SpiderGraph protocol.

PCB base reference: Würth: 653105131822
Molex: 53261-0571

Matting model: Würth: 653005113322
Molex: 51021-0500

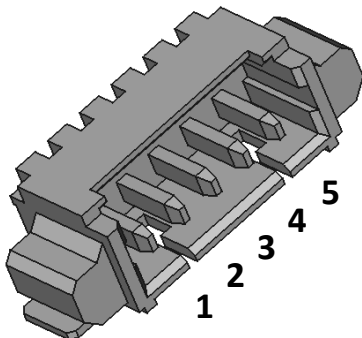

Pin number	I/O	Description
1	Power	Power Supply +12V
2	Power	GND
3	O	RS232 TX (EIA/232)
4	I	RS232 RX (EIA/232)
5	Power	GND

Chapter 5: Mechanical description

Unit: mm

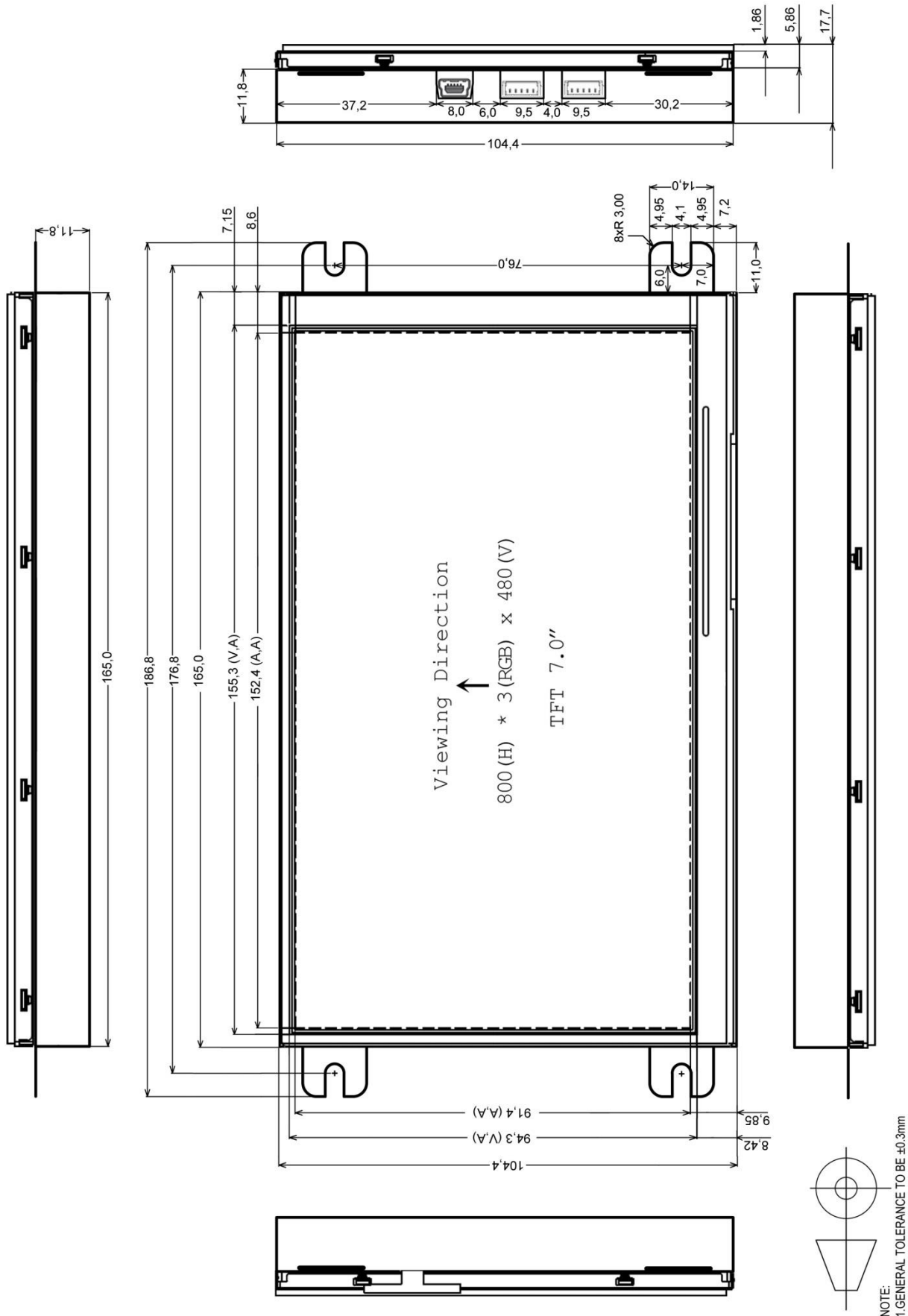

Chapter 6: Clairitec's contact

Clairitec

CLAIRITEC
11 avenue Henri Becquerel
33700 Mérignac
FRANCE

Web site: www.clairitec.com

Clairitec's services

Customer relation service: contact@clairitec.com

Technical support service: support@clairitec.com

Non-contractual pictures



11, avenue Henri Bequerel - 33700 - MERIGNAC - FRANCE

Email: contact@clairitec.com
www.clairitec.com



Компания «Life Electronics» занимается поставками электронных компонентов импортного и отечественного производства от производителей и со складов крупных дистрибьюторов Европы, Америки и Азии.

С конца 2013 года компания активно расширяет линейку поставок компонентов по направлению коаксиальный кабель, кварцевые генераторы и конденсаторы (керамические, пленочные, электролитические), за счёт заключения дистрибьюторских договоров

Мы предлагаем:

- Конкурентоспособные цены и скидки постоянным клиентам.
- Специальные условия для постоянных клиентов.
- Подбор аналогов.
- Поставку компонентов в любых объемах, удовлетворяющих вашим потребностям.
- Приемлемые сроки поставки, возможна ускоренная поставка.
- Доставку товара в любую точку России и стран СНГ.
- Комплексную поставку.
- Работу по проектам и поставку образцов.
- Формирование склада под заказчика.
- Сертификаты соответствия на поставляемую продукцию (по желанию клиента).
- Тестирование поставляемой продукции.
- Поставку компонентов, требующих военную и космическую приемку.
- Входной контроль качества.
- Наличие сертификата ISO.

В составе нашей компании организован Конструкторский отдел, призванный помогать разработчикам, и инженерам.

Конструкторский отдел помогает осуществить:

- Регистрацию проекта у производителя компонентов.
- Техническую поддержку проекта.
- Защиту от снятия компонента с производства.
- Оценку стоимости проекта по компонентам.
- Изготовление тестовой платы монтаж и пусконаладочные работы.



Тел: +7 (812) 336 43 04 (многоканальный)

Email: org@lifeelectronics.ru