

# ALCOSWITCH ANTI-VANDAL SWITCH SERIES

TE Connectivity's (TE) new ALCOSWITCH Anti-Vandal switch series is designed for security and reliability in a variety of panel mount industrial and building applications. The large pushbutton and available LED indicators illuminate the switch and allow for an easy user interface. The Anti-Vandal series is available in panel sizes of 16, 19, 22 and 25 mm, and with various pushbutton symbols including Spot, Ring, and Power Logo. Switches are sealed to IP67 and available in single and double pole configurations.



## Applications

- Industrial equipment
- Elevators/Escalators
- Instrumentation
- Communication equipment
- Control equipment

## Electrical

- RoHS Directive 2002/95/E compliant
- REACH Compliant and Pb Free
- UL (E46765) for AV19, AV22 series

## Mechanical

- Operating temperature: -20-+55° C

## Materials

- Contacts: Copper with silver or gold plating
- Actuator: Stainless Steel
- Terminals: Copper, silver plated
- Terminal seal: Silicon
- Case: PBT
- Bushing: Stainless steel

## Key Benefits

- Allow for an easy user interface with a large pushbutton and available LED indicators illuminate the switch
- Enable flexibility with various pushbutton symbols including Spot, Ring, and Power logo
- Achieve a vandal proof solution with a jam nut accessible for rear of the panel
- Ease of installation with available flying lead terminations.

### Typical Performance Characteristics

- Number of poles: 1 to 2
- Switch Functions: OFF-ON, OFF-(ON)
- Contact Rating: 2A @ 36VDC (16mm)  
3A @ 250VAC (19, 22, 25mm)
- Gold Contact: 0.4 VA @ 20V max
- Electrical life (pushbutton only):  
16mm: 200,000 cycles  
19/22/25mm: 50,000 cycles
- Contact resistance: 50mOhms max. @ 1A,  
12VDC (initial value)
- Insulation resistance: 1,000 MOhms min. @500VDC
- Dielectric strength: 2,000V for 1 minute
- Actuator force:  
16mm: 4.5 +/- 1.5 N  
19/22/25mm, Single Pole: 2.5 +/- 1.0 N  
19/22/25mm, Double Pole: 3.5 +/- 1.0 N
- Actuator travel:  
16mm: 2.0 mm  
19/22/25mm: 3.2 mm
- Life Expectancy:  
Momentary: 1,000,000 actuations  
Push On/Off: 500,000 actuation



### Dimensions

Part Number 2316365-1

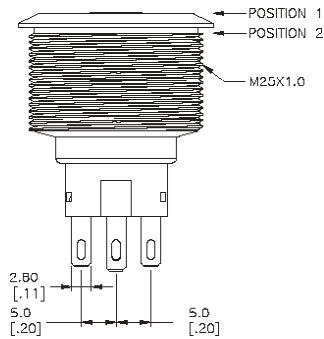
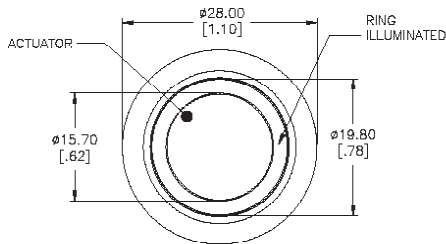

Part Number 2316366-1

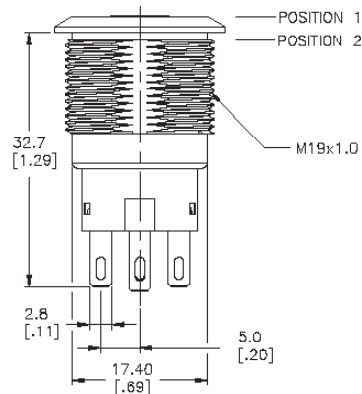
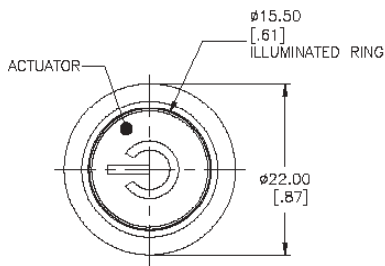

Product Key

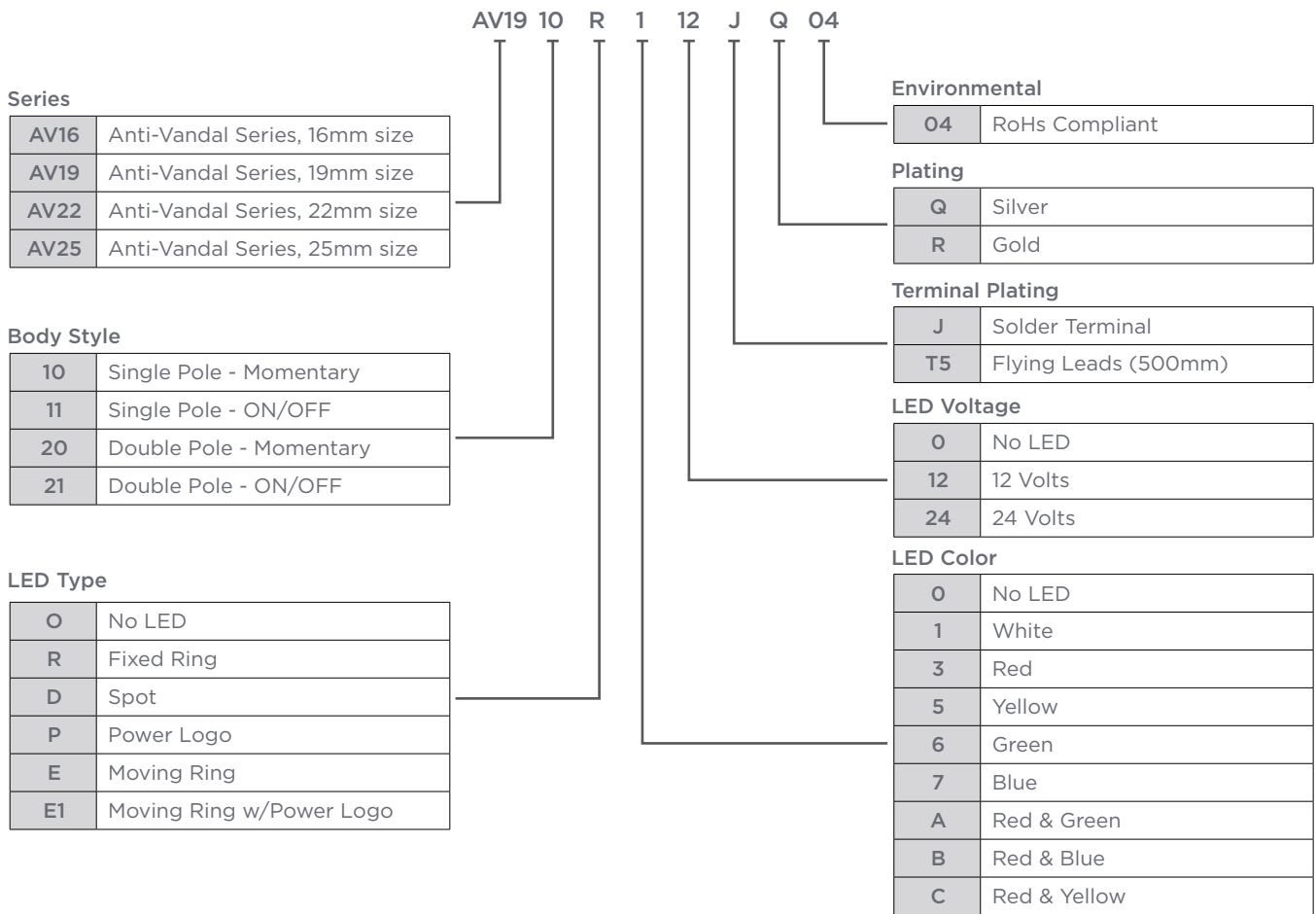

Product Selection Information

Product Key	Series	Body Style	LED color	LED voltage	Terminal Plating	TE PN
AV1610R112R04	16 mm	Single Pole - Momentary	White	12 Volts	Gold	<a href="#">2213774-1</a>
AV1910D512Q04	19 mm	Single Pole - Momentary	Yellow	12 Volts	Silver	<a href="#">2213765-9</a>
AV1910RAZ4Q04	19 mm	Single Pole - Momentary	Red / Green	24 Volts	Silver	<a href="#">2317404-2</a>
AV1910EG24T5Q04	19 mm	Single Pole - Momentary	Red / Yellow	24 Volts	Silver	<a href="#">3-2316531-5</a>
AV2210E324R04	22 mm	Single Pole - Momentary	Red	24 Volts	Gold	<a href="#">2213772-8</a>
AV2211EB12Q04	22 mm	Single Pole - Locking	Red / Blue	12 Volts	Silver	<a href="#">2317570-9</a>
AV2220EB12T5Q04	22 mm	Double Pole - Momentary	Red / Blue	12 Volts	Silver	<a href="#">4-2317570-4</a>
AV2510E312Q04	25 mm	Single Pole - Momentary	Red	12 Volts	Silver	<a href="#">2317656-3</a>
AV2521M124Q04	25 mm	Double Pole - Locking	White	24 Volts	Silver	<a href="#">2-2317658-6</a>
AV2511MB12T5Q04	25 mm	Single Pole - Locking	Red / Blue	12 Volts	Silver	<a href="#">2317659-7</a>

te.com

© 2017 TE Connectivity Ltd. Family of Companies. All Rights Reserved. ALCOSWITCH, TE, TE Connectivity, and the TE connectivity (logo) are trademarks of the TE Connectivity Ltd. family of companies. Other logos, product and Company names mentioned herein may be trademarks of their respective owners.

While TE has made every reasonable effort to ensure the accuracy of the information in this brochure, TE does not guarantee that it is error-free, nor does TE make any other representation, warranty or guarantee that the information is accurate, correct, reliable or current. TE reserves the right to make any adjustments to the information contained herein at any time without notice. TE expressly disclaims all implied warranties regarding the information contained herein, including, but not limited to, any implied warranties of merchantability or fitness for a particular purpose. The dimensions in this catalog are for reference purposes only and are subject to change without notice. Specifications are subject to change without notice. Consult TE for the latest dimensions and design specifications.

1-1773878-3 JN 5/2017

USA: +1 (800) 522-6752  
 Canada: +1 (905) 475-6222  
 Mexico: +52 (0) 55-1106-0800  
 Latin/S. America: +54 (0) 11-4733-2200  
 Germany: +49 (0) 6251-133-1999  
 UK: +44 (0) 800-267666  
 France: +33 (0) 1-3420-8686  
 The Netherlands: +31 (0) 73-6246-999  
 China: +86 (0) 400-820-6015

Компания «Life Electronics» занимается поставками электронных компонентов импортного и отечественного производства от производителей и со складов крупных дистрибьюторов Европы, Америки и Азии.

С конца 2013 года компания активно расширяет линейку поставок компонентов по направлению коаксиальный кабель, кварцевые генераторы и конденсаторы (керамические, пленочные, электролитические), за счёт заключения дистрибьюторских договоров

Мы предлагаем:

- Конкурентоспособные цены и скидки постоянным клиентам.
- Специальные условия для постоянных клиентов.
- Подбор аналогов.
- Поставку компонентов в любых объемах, удовлетворяющих вашим потребностям.
- Приемлемые сроки поставки, возможна ускоренная поставка.
- Доставку товара в любую точку России и стран СНГ.
- Комплексную поставку.
- Работу по проектам и поставку образцов.
- Формирование склада под заказчика.
- Сертификаты соответствия на поставляемую продукцию (по желанию клиента).
- Тестирование поставляемой продукции.
- Поставку компонентов, требующих военную и космическую приемку.
- Входной контроль качества.
- Наличие сертификата ISO.

В составе нашей компании организован Конструкторский отдел, призванный помогать разработчикам, и инженерам.

Конструкторский отдел помогает осуществить:

- Регистрацию проекта у производителя компонентов.
- Техническую поддержку проекта.
- Защиту от снятия компонента с производства.
- Оценку стоимости проекта по компонентам.
- Изготовление тестовой платы монтаж и пусконаладочные работы.



Тел: +7 (812) 336 43 04 (многоканальный)

Email: [org@lifeelectronics.ru](mailto:org@lifeelectronics.ru)