

Tiny ROM GNSS module

Datasheet - production data



Features

- Simultaneous multi-constellation
- -163 dBm tracking sensitivity
- 1.5 m CEP position accuracy
- 2.1 V to 4.3 V supply voltage range
- Tiny LCC 18 pin package (9.7x10.1)
- Operating temperature (-40 °C, 85 °C)
- 17 μ W standby current and 70 mW tracking power consumption

Description

The Teseo-LIV3R module is an easy to use Global Navigation Satellite System (GNSS)

standalone module, embedding Teseo III single die standalone positioning receiver IC working simultaneously on multiple constellations (GPS/Glonass/BeiDou/QZSS).

The Teseo-LIV3R modules bring the proven accuracy and robustness of Teseo chips to the reach of everyone. The certified module with optimized RF, embedded firmware and the complete evaluation environment save development time, while the compactness and cost-effectiveness of this solution make it ideal for many, especially IoT applications, such as insurance, goods tracking, drones, tolling, anti-theft systems, people and pet location, vehicle tracking, emergency calls, fleet management, vehicle sharing, diagnostics and public transportation.

Within its 9.7x10.1 mm tiny size, Teseo-LIV3R is offering superior accuracy thanks to the on board 26 MHz Temperature Compensated Crystal Oscillator (TCXO) and a reduced Time To First Fix (TTFF) relying on its dedicated 32 KHz Real Time Clock (RTC) oscillator.

Teseo-LIV3R also provides server based Real Time Assisted GNSS.

Teseo-LIV3R module, being a certified solution, optimizes the time to market of the final applications with a temperature operating range from -40 °C to 85 °C.

Table 1. Device summary

Order code	Marking	Temperature range	Package	Packaging
Teseo-LIV3R	Teseo-LIV3R	-40 °C, 85 °C	LCC-18 (9.7 mm x 10.1 mm)	Tape and reel

Contents

- 1 General description 4**
 - 1.1 GNSS performance 4
 - 1.2 Block diagram 5
 - 1.3 Pin configuration 6
 - 1.4 Pin out description 6

- 2 Supported GNSS constellations 8**
 - 2.1 GPS 8
 - 2.2 GLONASS 8
 - 2.3 BeiDou 8

- 3 Augmentation systems 9**
 - 3.1 Satellite-Based augmentation system 9
 - 3.2 QZSS 9
 - 3.3 Differential GPS 9

- 4 Assisted GNSS 11**
 - 4.1 RealTime AGNSS 11

- 5 Clock generation 12**
 - 5.1 Temperature-Compensated Crystal Oscillator (TCXO) 12
 - 5.2 Real Time Clock (RTC) 12

- 6 I/O interfaces 13**
 - 6.1 UART 13
 - 6.2 I2C 13

- 7 FW configuration 14**

- 8 Power mode 15**
 - 8.1 Hardware standby 15
 - 8.2 Software standby 15

9	Geofencing	16
10	Odometer	17
11	Regulatory compliance	18
	11.1 CE certification for Teseo-LIV3R	18
12	Electrical characteristics	19
	12.1 Parameter conditions	19
	12.2 Minimum and maximum values	19
	12.3 Typical values	19
	12.4 Absolute maximum ratings	19
	12.5 Recommended DC operating conditions	20
13	Mechanical specifications	21
14	Shipping information	22
	14.1 Reels	22
	14.2 Packing cartons for reels	24
	14.3 ESD handling precautions	24
	14.4 Moisture sensitivity levels	24
15	Labeling information	25
16	Reflow soldering profile	26
17	ECOPACK®	27
Appendix A Reference document		28
Revision history		29

1 General description

1.1 GNSS performance

Receiver specifications are the following:

- GPS L1C/A
- SBAS L1C/A
- QZSS L1C/A
- GLONASS L1OF
- BeiDou B1

Table 2. GNSS performance

Parameter	GNSS	GPS & GLONASS	GPS & BeiDou	Unit
Time To First Fix ⁽¹⁾	Cold start Warm start	<32 <25	<36 <29	s
	Hot start	<1.5	<2.5	
Sensitivity ^{(2),(3),(4)}	Tracking	-163	-163	dBm
	Navigation ⁽⁵⁾	-158	-158	
	Reacquisition ^{(6),(7)}	-156	-156	
	Cold start	-147	-147	
	Warm start	-148	-148	
	Hot start	-154	-151	
Max fix rate	—	10	10	Hz
Velocity accuracy ⁽⁸⁾	—	0.01	—	m/s
Velocity accuracy ⁽⁹⁾	—	0.1	—	m/s
Heading accuracy ⁽⁸⁾	—	0.01	—	°
Heading accuracy ⁽⁹⁾	—	2.3	—	°
Horizontal position accuracy ⁽¹⁰⁾	Autonomous	<1.8 ⁽¹⁰⁾	<1.5 ⁽¹⁰⁾	m
	SBAS	<1.5 ⁽¹⁰⁾	—	
Accuracy of time pulse	RMS 99%	—	—	—
Frequency of time pulse	—	—	—	—
Operational limits ⁽¹¹⁾	Dynamic ⁽¹²⁾	<4.5g	<4g	—
	Altitude	100000	100000	m
	Velocity	600	600	m/s
Operational ITAR limits ⁽¹³⁾	Altitude	18000	18000	m
	Velocity	515	515	m/s

1. All satellites at -130 dBm - TTFF at 50%.
2. Demonstrated with a good external LNA.

3. For hot start, all sats have the same signal level except one (pilot sat at -145 dBm).
4. For BEIDOU tracking sensitivity refers to MEO sats. For GEO the tracking sensitivity is -151 dBm
5. Configurable Value.
6. All satellites at same signal level.
7. Minimum level to get valid fix after reacquisition.
8. 50% at 30 m/s - linear path.
9. 50% at 0.5 g - shape path.
10. CEP 50%, 24h static, Roof Antenna.
11. Verified the limit checking the fix availability.
12. Special configuration for high dynamic scenario.
13. To be compliant with USA International Traffic in Arms Regulations (ITAR), when both the ITAR altitude limit and the ITAR velocity limit are overpass taken the Teseo-LIV3R stops providing NMEA stream.

1.2 Block diagram

Figure 1. Teseo-LIV3R block schematic

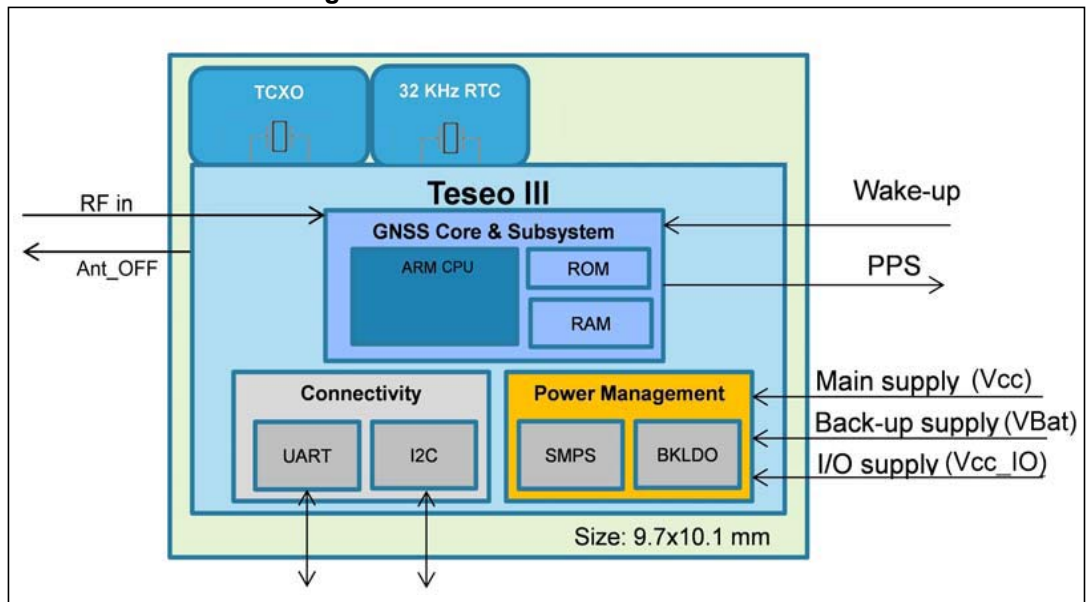

1.3 Pin configuration

Figure 2. Teseo-LIV3R pin layout

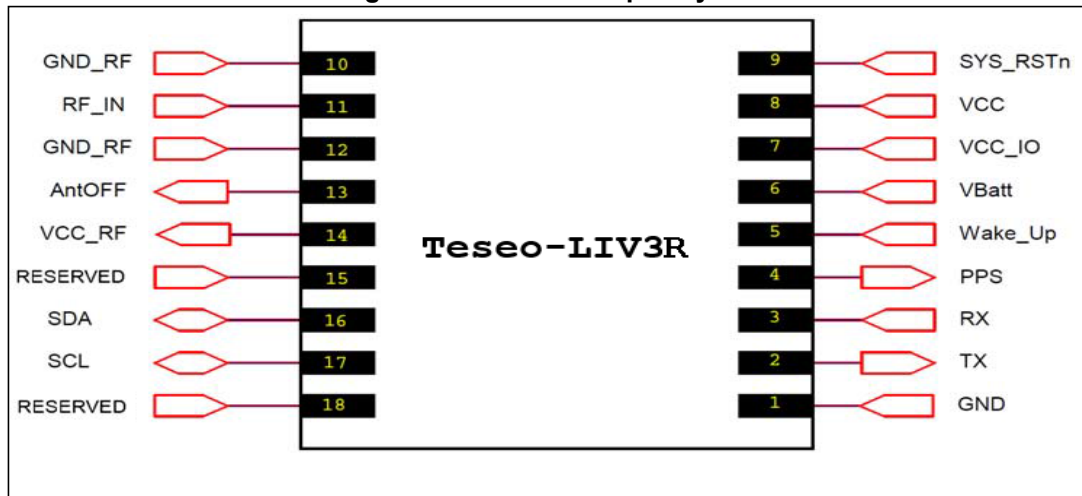

1.4 Pin out description

Table 3. Teseo-LIV3R pin out description

No	Name	I/O	Description
1	GND	Ground	Ground
2	TX	O	Serial Port Tx (if not used, must be left floating)
3	RX	I	Serial Port Rx
4	1PPS	O	Time pulse (1PPS) (if not used, must be left floating)
5	Wake-Up	I	External Interrupt Pin (if not used, must be left floating)
6	Vbatt	I	Backup voltage supply
7	VCC_IO	I	IO Supply Voltage (3.3 V)
8	VCC	I	Supply voltage (from 2.1 V to 4.2 V)
9	SYS_RSTn	I	RESET_N (if not used, must be left floating)
10	GND_RF	I	Ground
11	RF_IN	I	GNSS signal Input
12	GND_RF	Ground	Ground
13	Ant_OFF	O	External Antenna Control (if not used, must be left floating)
14	VCC_RF	O	Output Voltage RF section (if not used, must be left floating) ⁽¹⁾
15	Reserved	I	Reserved (must be left floating)
16	SDA	I/O	I2C Data (if not used, must be left floating)

Table 3. Teseo-LIV3R pin out description (continued)

No	Name	I/O	Description
17	SCL	I/O	I2C Clock (if not used, must be left floating)
18	Reserved	I	Reserved (must be left floating)

1. Can be used to supply external active antenna.

2 Supported GNSS constellations

The embedded FW supports the following GNSS constellations (GPS, GLONASS, BEIDOU and QZSS). The user can select what the application needs by FW configuration. GPS+GLONASS are selected by default.

2.1 GPS

The Teseo-LIV3R GNSS module is designed to receive and to track the L1C/A signals provided at 1575.42 MHz by the Global Positioning System (GPS). The Teseo-LIV3R can receive and process GPS concurrently with GLONASS or BeiDou (the last two are mutually exclusive).

2.2 GLONASS

The Teseo-LIV3R module can receive and process GLONASS concurrently with GPS. The Russian GLONASS satellite system (ГЛОУАСС; GLOBal NAVigation Satellite System) is an alternative to US's GPS.

2.3 BeiDou

The Teseo-LIV3R module can receive and process BeiDou concurrently with GPS. B1 signals provided at 1561.098 MHz by the BeiDou Navigation Satellite System can be tracked by Teseo-LIV3R positioning modules. The ability to receive and track BeiDou B1 satellite signals in conjunction with GPS results in higher coverage, improved reliability and better accuracy especially in the difficult urban environment of the big far east cities like Shanghai, Taipei, and Singapore.

3 Augmentation systems

3.1 Satellite-Based augmentation system

Teseo-LIV3R supports SBAS. SBAS is a Wide Area Differential GPS (WADGPS). It is a system which provides differential GPS corrections data; SBAS includes the WAAS within the United States, the EGNOS within Europe, the Multifunctional Transport Satellite (MTSAT)-based MSAS within Japan and Southeast Asia, and the GPS and GEO Augmented Navigation (GAGAN) system in India.

SBAS data correction is used in the GNSS algorithm to provide better position estimation.

The overall SBAS differential correction mechanism can be conceived and built in 2 phases:

- The “Acquire and Tracking” phase
- The “Decoding” phase

The “Acquire and Track” phase relates to the capacity of the acquisition engine to reliably track the configured SBAS satellite; during decoding phase the SBAS message can be decoded to fetch the differential corrections.

The current longitude limits for each service are:

- WAAS -180 to -25 degrees
- EGNOS -25 degrees to +50 degrees
- GAGAN +50 degrees to +100 degrees
- MSAS +100 degrees to +180 degrees

The Teseo-LIV3R software with SBAS capability implements a command interface at the NMEA level to allow interaction with the SBAS library. It supports commands to enable/disable the SBAS functionality.

3.2 QZSS

The Quasi-Zenith Satellite System (QZSS) is a Japanese regional communication service and positioning information for the mobile environment in the GPS L1C/A band. QZSS in conjunction with GPS signals provides GNSS augmentation service for the Pacific region covering Japan and Australia. QZSS satellites are placed in a periodic Highly Elliptical Orbit (HEO); these orbits allow the satellites to “dwell” for more than 12 hours a day at an elevation above 70° (it means that they appear almost overhead most of the time).

3.3 Differential GPS

Teseo-LIV3R supports Differential-GPS data according to RTCM (Radio Technical Commission for Maritime Services) 2.3.

Differential-GPS data improves position accuracy.

Teseo-LIV3R supports the following RTCM messages.

Table 4. Supported RTCM message on Teseo-LIV3R

Message Type	Description
1	Differential GPS Corrections
9	GPS Partial Correction Set
31	Differential GLONASS Corrections
34	GLONASS Partial Correction Set

4 Assisted GNSS

GNSS receivers need accurate satellite position data from at least four satellites to produce a fix.

Accurate satellite data -ephemeris data- is valid for 4 hours only for GPS and 30 minutes only for GLONASS.

After that time, a receiver must download new ephemeris data.

Ephemeris download can take from dozens of seconds to several minutes, hours or may fail to download.

Assisted-GNSS is a mechanism to provide ephemeris assistance from external source, this reduces considerably the time to get fix especially in critical environments when the ephemeris download time could be very long.

Teseo-LIV3R supports the Real-Time Assisted GNSS.

4.1 RealTime AGNSS

RealTime Assisted GNSS (RT-AGNSS) is a server based Assisted GNSS solution, therefore it requires a network connection to download assistance data from the server.

RT-AGNSS works by downloading from an assistance server the real time ephemeris data. Server access is allowed thanks to internal keyword provided by Teseo-LIV3R to the Host processor and the acquired real-time data has to be provided to Teseo-LIV3R.

Proprietary NMEA commands are supported on Teseo-LIV3R to acquire the credential access to the external server and to inject the data to Teseo-LIV3R.

STMicroelectronics partner provides available server solution access for free on Teseo-LIV3R solution.

RealTime A-GNSS allows continuous real-time satellite position determination.

5 Clock generation

5.1 Temperature-Compensated Crystal Oscillator (TCXO)

Highly stable 26 MHz oscillator controls the down conversion process in RF block of the Teseo-LIV3R. Characteristics of this component are important factors for higher sensitivity to maximize performance especially in weak-signal environments, as well as to minimize TTF (Time To First Fix) and improve navigation stability.

5.2 Real Time Clock (RTC)

This is an always-on power domain dedicated to RTC logic (backup system) with 32 KB SRAM and supplied with a dedicated voltage regulator.

The RTC provides a high resolution clock which can be used for GPS. It keeps the time when the system is inactive and it is internally used to wake up the system when in low power mode. It has a clock trimming feature to compensate for the accuracy of the 32.768 KHz crystal and a secured time update.

6 I/O interfaces

Teseo-LIV3R supports two I/O interfaces:

- UART
- I2C

Both these interfaces support NMEA protocol.

6.1 UART

The Universal Asynchronous Receiver/Transmitter (UART) supports much of the functionality of the industry-standard 16C450 UART.

The UART performs serial-to-parallel conversion on data asynchronously received from a peripheral device on RX0 pin, and parallel-to-serial conversion on data written by CPU for transmission on TX0 pin. The transmit and receive paths are buffered with internal FIFO memories allowing up to 64 data byte for transmission, and 64 data byte with 4-bit status (break, frame, parity, and overrun) for receive.

6.2 I2C

Teseo-LIV3R includes a slave I2C interface configurable; I2C is a two-wire communication interface invented by Philips Semiconductor.

Unlike all other interfaces, I2C is not able to communicate in full-duplex mode; it uses only two bidirectional open-drain lines, Serial Data Line on pin SDA and Serial Clock Line on pin SCL, pulled up with resistors.

Teseo-LIV3R receiver always acts as slave and it cannot initiate data transmission on the bus; host has to periodically pull the receiver to check about data availability.

The main features are:

- Normal speed (100 KHz) and Fast speed (400 KHz) supported
- I2C-slave address configurable using the firmware configurator

7 FW configuration

All configuration parameters are grouped in a data block. Each field is addressed by a unique ID. The IDs are made by three digits: the most significant one represents the parameter type and the others are used to identify different parameters of the same type. Default setting of configuration data block is hard coded into the binary image file.

A new configuration can be built using the PC Tool Teseo-Suite, available at www.st.com or using runtime configuration commands raised by the host.

Teseo-LIV3R firmware configuration is maintained until voltage supply on VBAT pin (6) is provided.

8 Power mode

Standby mode, is the mode where only low power backup domain is running. It means VBAT must be always maintained. It allows to have very low current consumption and fast GNSS reacquisition at the end of the standby time due to RTC.

Teseo-LIV3R offers two different ways of standby:

- Hardware standby
- Software standby

8.1 Hardware standby

This standby is ensured by switching OFF VCC (pin 6) and VCC_IO (pin 7) supplies and setting SYS_RESETEn (pin 9) to 0 V. It can be activated asynchronously from GNSS binary with one GPIO switching OFF the supplies from a host.

During this standby only VBAT (pin 6) is kept ON.

It ensures a current below 6 μ A. During this standby mode VCC_RF (pin 14) is OFF.

8.2 Software standby

Software standby is activated by the internal binary.

Software standby can be:

- Host driven standby: where the host sends a NMEA commands to force Teseo-LIV3R into standby; host can be woken up by Teseo-LIV3R using the Wakeup pin (pin 5);
- Periodic standby: where Teseo-LIV3R enters and exits from standby using internal RTC. Periodic fixes are from 5 seconds up to 24 hours between 2 fixes.

It ensures a current below 12 μ A on Teseo-LIV3R. Be careful that VCC_RF is ON during this standby. In case of active antenna or external LNA, it is important to switch them OFF.

9 Geofencing

Geofence feature allows the Teseo-LIV3R receiver to raise an autonomous NMEA message when the resolved GNSS position is close to a specific circle, entering or exiting from a circle.

Teseo-LIV3R receiver supports at least 8 circular areas.

Geofencing alarm can be notified over proprietary NMEA message.

Geofencing can be configured and enabled in the firmware configurator or using the specific geofencing configuration command.

10 Odometer

Teseo-LIV3R receiver supports Odometer feature.

Odometer provides information on the traveled distance using only positioning information.

Odometer can be configured using specific odometer commands during the runtime.

While enabled the odometer reports the ground distance from the last reset.

Odometer is also able to raise an autonomous message alarm when a programmed distance is reached.

11 Regulatory compliance

11.1 CE certification for Teseo-LIV3R

The Teseo-LIV3R module has been certified according to the following standards:

- Radio Equipment Directive (RED) 2014/53/EU
- EN 60950-1:2006 + A11:2009 + A1:2010 + A12:2011 + A2:2013
- EN62479:2010
- ETSI EN 301 489-1 V2.2.0 + ETSI EN 301 489-19 V2.1.0
- ETSI EN 303 413 V1.1.1

The module is provided by CE marking:

Figure 3. CE marking

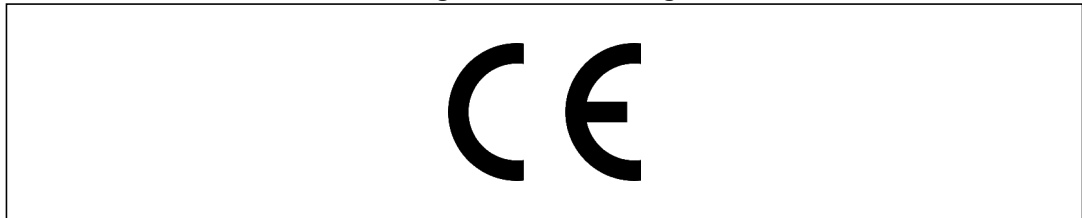

The Certificate of Conformity is available/downloadable at the following webpage:

www.st.com at the [teseo-liv3r](#) page.

For additional information please refer to:

STMicroelectronics Via C. Olivetti, 2 Agrate Brianza (MB) 20864 (ITALY).

The Teseo-LIV3R module current production firmware release is:

\$PSTMVER,GNSSLIB_8.x.x.xx_ARM*xx

The manufacturer, STMicroelectronics, declares that the Teseo-LIV3R radio equipment complies with the 2014/53/UE directive.

The full text of the EU declaration of conformity is available at the following Internet address:

www.st.com at the [teseo-liv3r](#) page.

12 Electrical characteristics

12.1 Parameter conditions

Unless otherwise specified, all voltages are referred to GND.

12.2 Minimum and maximum values

Unless otherwise specified the minimum and maximum values are guaranteed in the worst conditions of ambient temperature, supply voltage and frequencies by tests in production on 100% of the devices with an ambient temperature at $T_c = 25\text{ °C}$.

12.3 Typical values

Unless otherwise specified, typical data are based on $T_c = 25\text{ °C}$, $V_{CC} = 3.3\text{ V}$, $V_{CC_IO} = 3.3\text{ V}$. They are given only as design guidelines and are not tested.

Unless otherwise specified, all typical curves are given only as design guidelines and are not tested.

12.4 Absolute maximum ratings

This product contains devices to protect the inputs against damage due to high static voltages, however it is advisable to take normal precautions to avoid application of any voltage higher than the specified maximum rated voltages.

Table 5. Voltage characteristics

Symbol	Parameter	Min	Max	Unit
VCC	Digital supply voltage	2.1	4.3	V
VBAT	Backup LDO input supply voltage	2.1	4.3	V

Table 6. Thermal characteristics

Symbol	Parameter	Min	Max	Unit
Toper	Operative ambient temperature	-40	85	°C

Table 7. Power consumption

Symbol	Parameter	Test condition	Typ	Unit
Pw	Power consumption in standard condition	G2 = GPS only; T _c = 25 °C; VCC = 2.1 V; VCC_IO = 3.3 V	75.8	mW
		G2 = GPS/Glonass; T _c = 25 °C; VCC = 2.1 V; VCC_IO = 3.3 V	93.4	mW
		G2 = GPS/Beidou; T _c = 25 °C; VCC = 2.1 V; VCC_IO = 3.3 V	90.4	mW
PWStandby	Power consumption STANDBY mode	RTC running = 32.768 KHz; T _c = 25 °C; VCC = VCC_IO = 0 V Vbat = 3.3 V	19.8	μW

12.5 Recommended DC operating conditions

Table 8. Recommended DC operating conditions

Symbol	Parameter	Min	Typ	Max	Unit
VCC	Power supply pins	2.1	3.3	4.3	V
VCC_Bat	Power supply pins for backup internal logic	2.1	3.3	4.3	V
VCC_IO	IO Supply Voltage	3.0	3.3	3.60	V

13 Mechanical specifications

Figure 4. Teseo-LIV3R mechanical specification

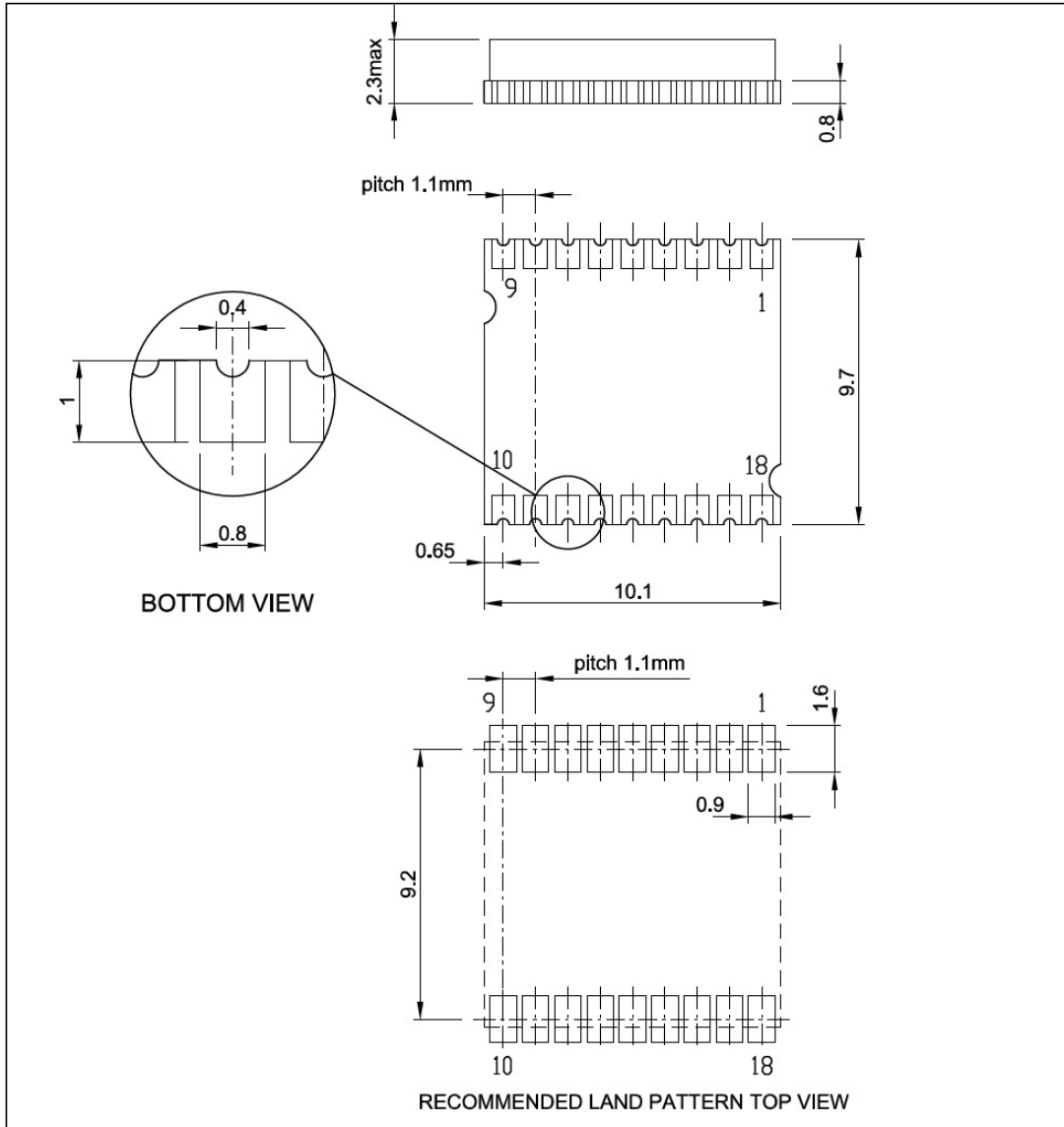

14 Shipping information

Teseo-LIV3R is delivered as reeled tapes.

For protection from physical damage, the reels are individually packed in cartons.

14.1 Reels

Teseo-LIV3R reel specification is as shown in *Figure 5*

Figure 5. Carrier tape

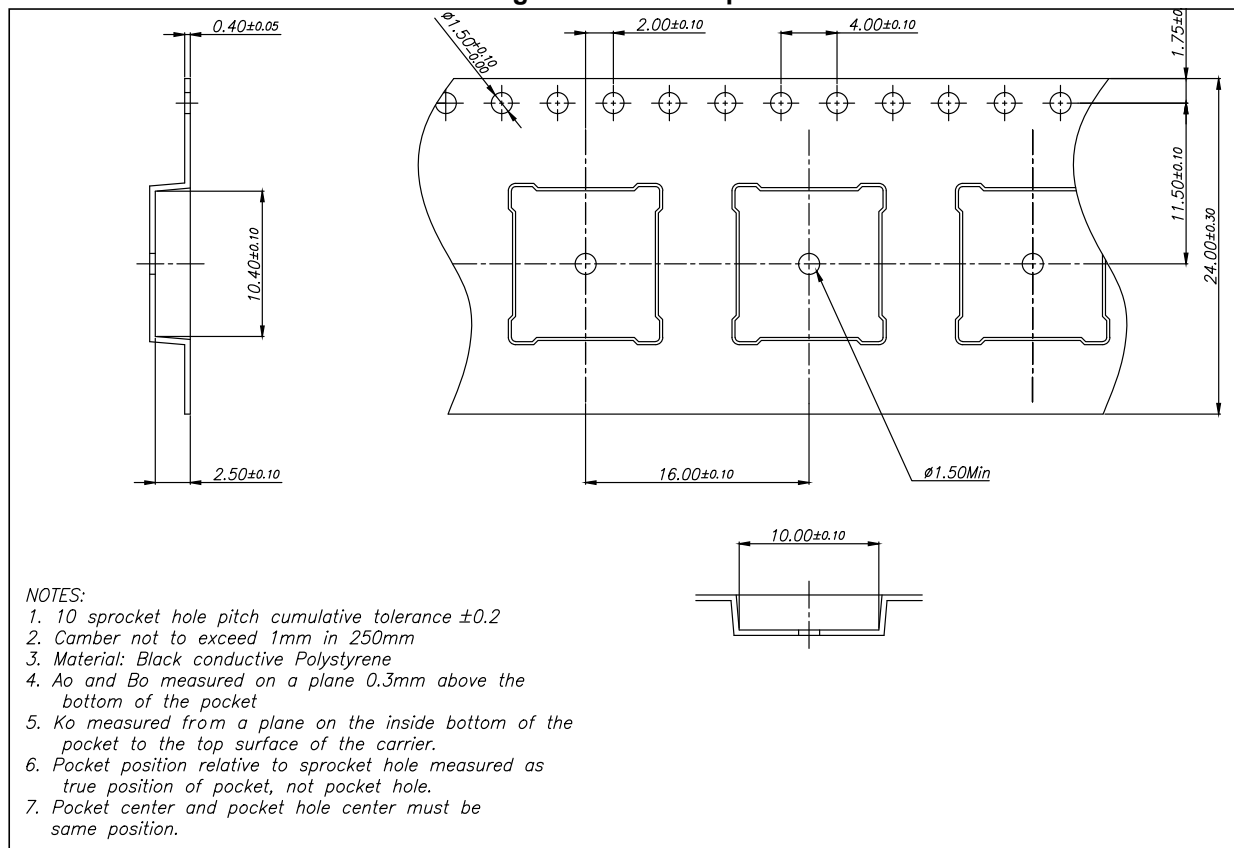

Figure 6. Teseo-LIV3R orientation

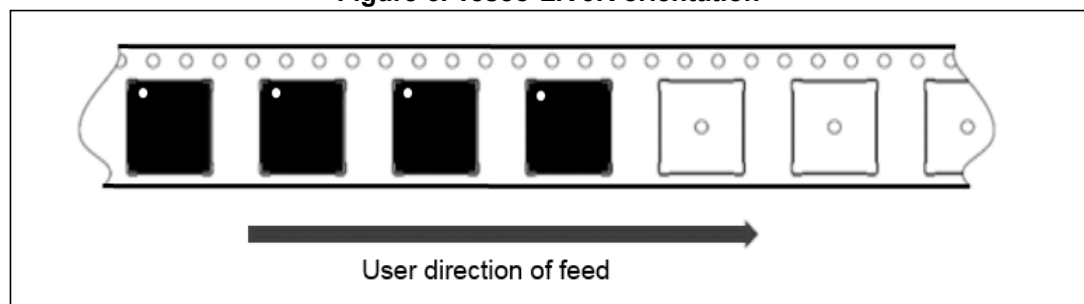

Figure 7. Cover tape

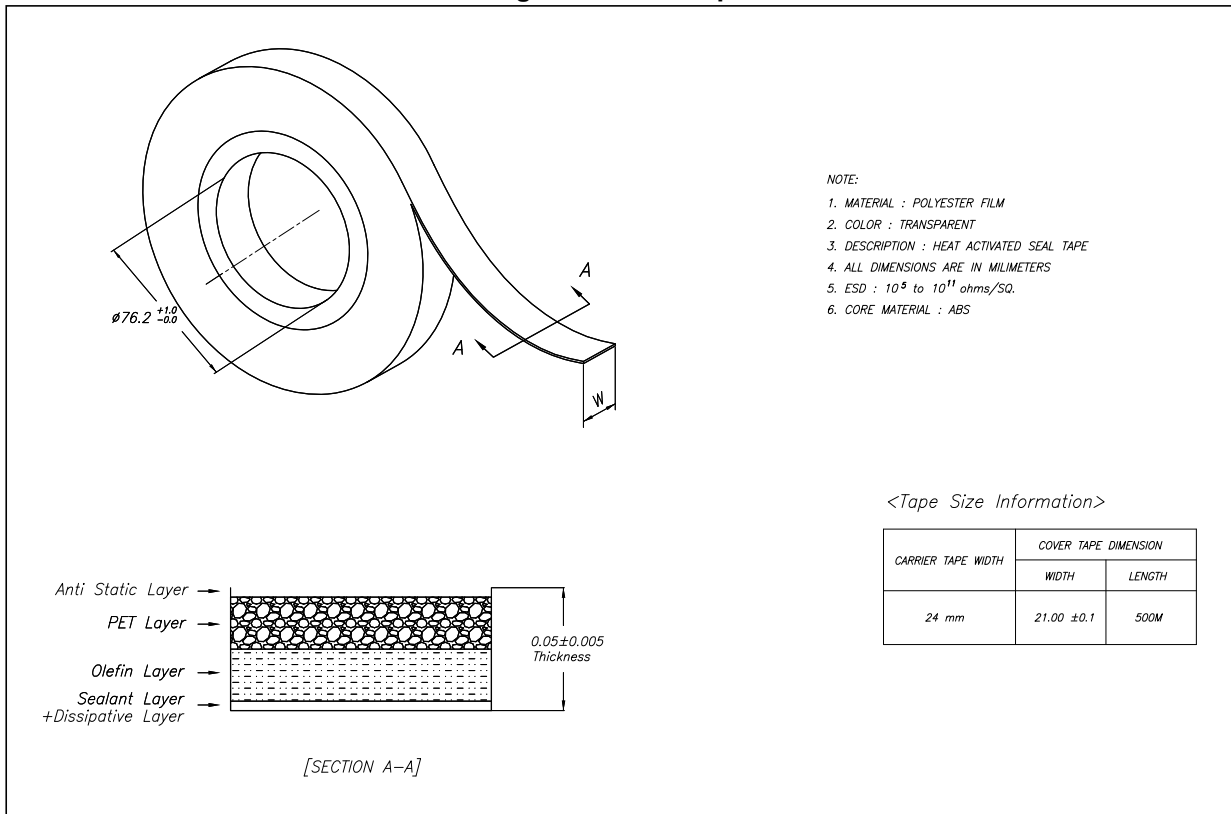

Figure 8. Plastic reel

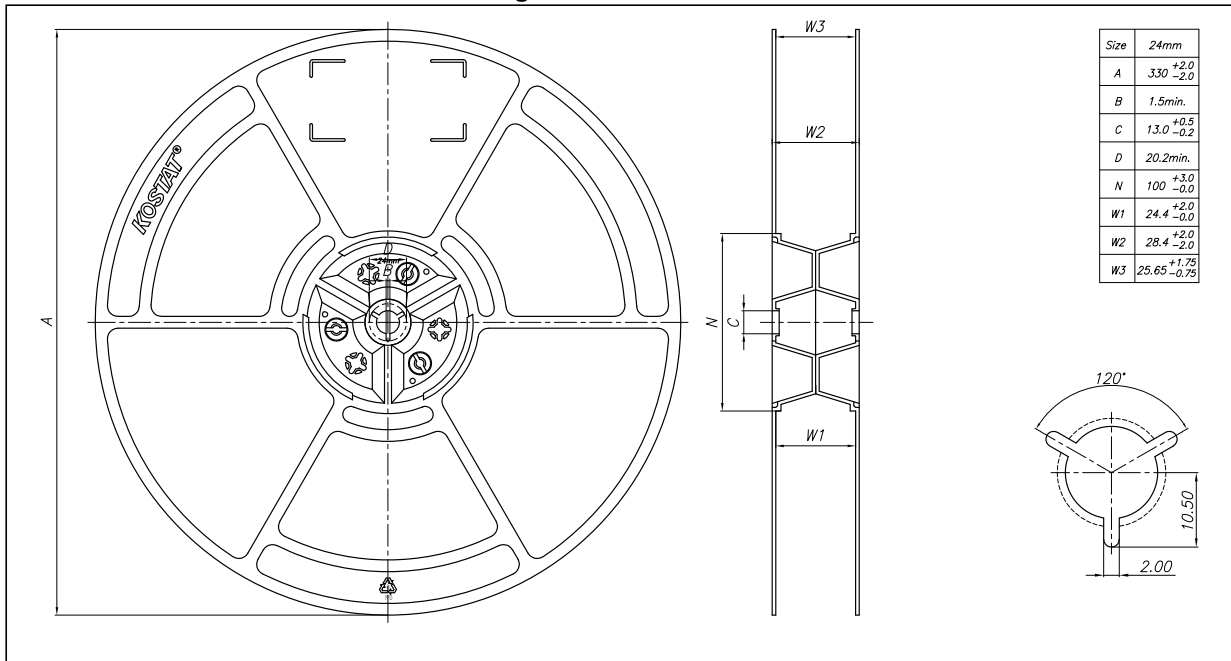
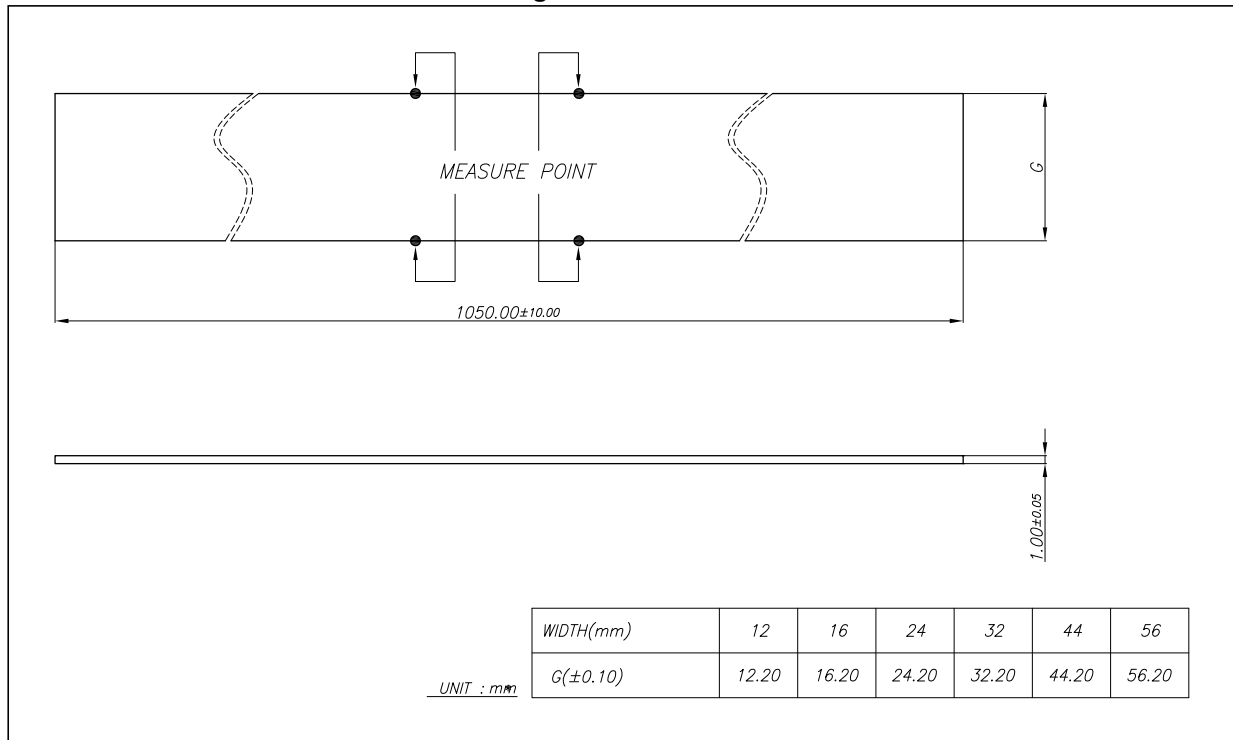

Figure 9. PB band



14.2 Packing cartons for reels

To avoid damage each Teseo-LIV3R reel has a dedicated carton box of 340 x 340 x 38 mm.

14.3 ESD handling precautions

Teseo-LIV3R module is Electrostatic Sensitive Device (ESD). Observe precautions for handling! Failure to observe these precautions can result in severe damage to the GNSS receiver.

GNSS receivers are Electrostatic Sensitive Devices (ESD) and require special precautions when handling. Particular care must be exercised when handling patch antennas, due to the risk of electrostatic charges.

14.4 Moisture sensitivity levels

The Moisture Sensitivity Level (MSL) relates to the packaging and handling precautions required.

Teseo-LIV3R modules are rated at MSL level 3 (three).

15 Labeling information

The labeling of Teseo-LIV3R reports product information.

Information layout of the product is shown in [Figure 10](#)

Figure 10. Labeling information of Teseo-LIV3R

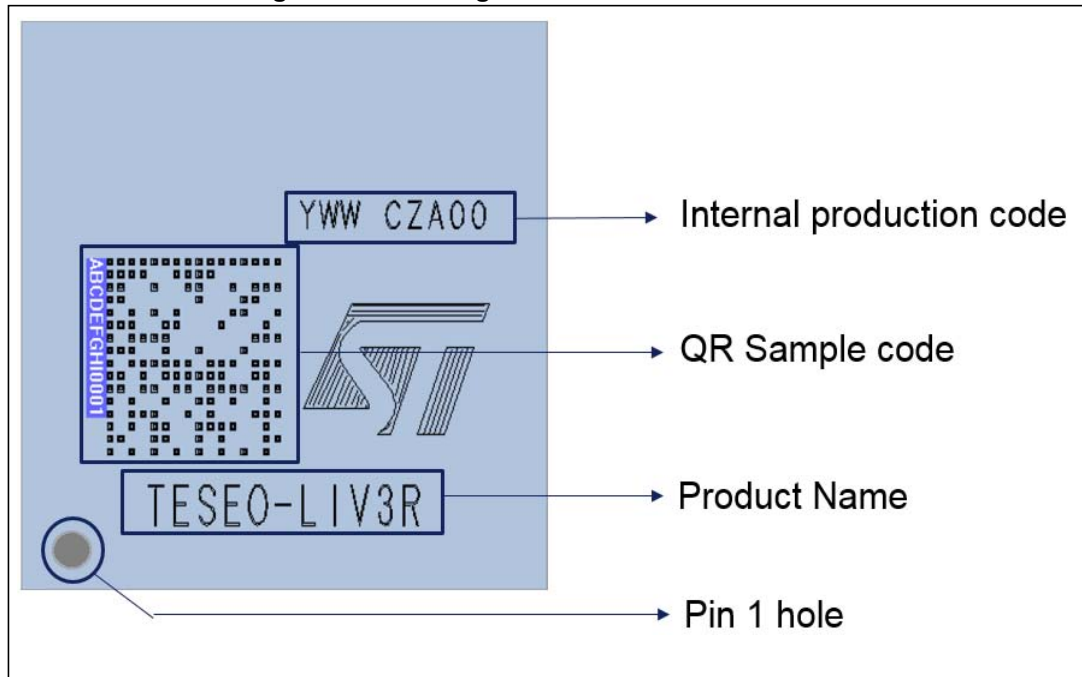

Information description is reported in [Table 9](#).

Table 9. Labeling information description

Items	Description
Internal production code	Information code related only to the production line
QR Sample code	QR Sample code used for traceability information of any parts
Product Name	Official product name for Ordering Code
Pin 1 hole	Hole on the shield to identify Pin 1

16 Reflow soldering profile

The Teseo-LIV3R is a high temperature strength surface mount GNSS module supplied on a 18-pin, 6-layer PCB. The final assembly recommended reflow profiles are indicated here below.

Soldering phase has to be executed with care: in order to avoid undesired melting phenomenon, particular attention has to be taken on the set up of the peak temperature.

Some suggestions for the temperature profile are reported in the following recommendations.

Table 10. Soldering profile values

Profile feature	PB-free assembly
Average ramp-up rate ($T_{S_{MAX}}$ to T_P)	3 °C/sec max
Preheat:	
– Temperature min ($T_{S_{min}}$)	150 °C
– Temperature max ($T_{S_{max}}$)	200 °C
– Time ($t_{S_{min}}$ to $t_{S_{max}}$) (t_S)	60-100 sec
Time maintained above:	
– Temperature (T_L)	217 °C
– Time (t_L)	60-70 sec
Peak temperature (T_P)	245 +/- 5 °C
Time within 5 °C of actual peak temperature (T_P)	10-20 sec
Ramp-down rate	6 °C/sec
Time from 25 °C to peak temperature	8 minute max.

Figure 11. Soldering profiles

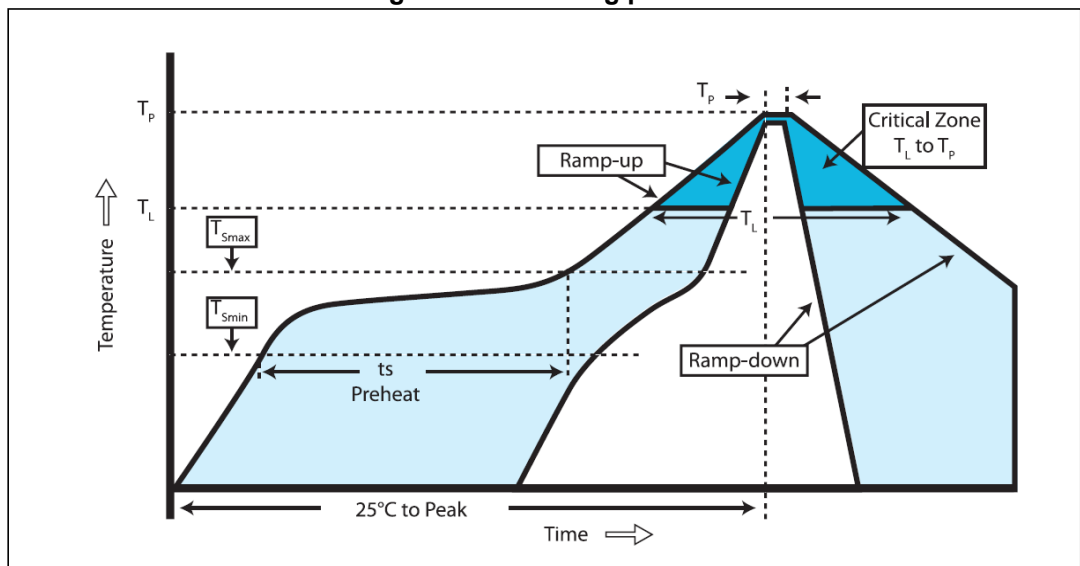

17 ECOPACK®

In order to meet environmental requirements, ST offers these devices in different grades of *ECOPACK* packages, depending on their level of environmental compliance. ECOPACK specifications, grade definitions and product status are available at: www.st.com. ECOPACK is an ST trademark.

Appendix A Reference document

1. *Teseo Suite – data brief* (DB3224, DocID030398)

Revision history

Table 11. Revision history

Date	Revision	Changes
15-Nov-2018	1	Initial release.
10-Jun-2019	2	Added <i>Section 11: Regulatory compliance on page 18</i> ; Updated <i>Table 7: Power consumption on page 20</i> .

IMPORTANT NOTICE – PLEASE READ CAREFULLY

STMicroelectronics NV and its subsidiaries (“ST”) reserve the right to make changes, corrections, enhancements, modifications, and improvements to ST products and/or to this document at any time without notice. Purchasers should obtain the latest relevant information on ST products before placing orders. ST products are sold pursuant to ST’s terms and conditions of sale in place at the time of order acknowledgement.

Purchasers are solely responsible for the choice, selection, and use of ST products and ST assumes no liability for application assistance or the design of Purchasers’ products.

No license, express or implied, to any intellectual property right is granted by ST herein.

Resale of ST products with provisions different from the information set forth herein shall void any warranty granted by ST for such product.

ST and the ST logo are trademarks of ST. For additional information about ST trademarks, please refer to www.st.com/trademarks. All other product or service names are the property of their respective owners.

Information in this document supersedes and replaces information previously supplied in any prior versions of this document.

© 2019 STMicroelectronics – All rights reserved

Компания «Life Electronics» занимается поставками электронных компонентов импортного и отечественного производства от производителей и со складов крупных дистрибьюторов Европы, Америки и Азии.

С конца 2013 года компания активно расширяет линейку поставок компонентов по направлению коаксиальный кабель, кварцевые генераторы и конденсаторы (керамические, пленочные, электролитические), за счёт заключения дистрибьюторских договоров

Мы предлагаем:

- Конкуренспособные цены и скидки постоянным клиентам.
- Специальные условия для постоянных клиентов.
- Подбор аналогов.
- Поставку компонентов в любых объемах, удовлетворяющих вашим потребностям.
- Приемлемые сроки поставки, возможна ускоренная поставка.
- Доставку товара в любую точку России и стран СНГ.
- Комплексную поставку.
- Работу по проектам и поставку образцов.
- Формирование склада под заказчика.
- Сертификаты соответствия на поставляемую продукцию (по желанию клиента).
- Тестирование поставляемой продукции.
- Поставку компонентов, требующих военную и космическую приемку.
- Входной контроль качества.
- Наличие сертификата ISO.

В составе нашей компании организован Конструкторский отдел, призванный помогать разработчикам, и инженерам.

Конструкторский отдел помогает осуществить:

- Регистрацию проекта у производителя компонентов.
- Техническую поддержку проекта.
- Защиту от снятия компонента с производства.
- Оценку стоимости проекта по компонентам.
- Изготовление тестовой платы монтаж и пусконаладочные работы.



Тел: +7 (812) 336 43 04 (многоканальный)

Email: org@lifeelectronics.ru

www.lifeelectronics.ru