

MC3, MC4 and MC6 Series Safety Mat Controllers

The MC Series safety mat controllers are used in conjunction with a four-wire, normally open, safety mat where perimeter guarding is required. These control reliable controllers send a stop signal to the guarded machine when an object of sufficient weight is detected on the active mat area.

The MC Series controllers, when combined with a four-wire UM or UMQ series mat, provide access guarding and improved productivity. The work area is fully visible and accessible.

The controller meets the requirement of EN 1760-1:1998, EN 954, ANSI/RIA 15.06-1999, ANSI B11.19-2003, OSHA 1910-217C, CSA and UL508.



MC6

- Universal power input
- Up to 6 mat zone inputs
- Six mat zone status indicator LEDs
- Select from Automatic Start, Start/Restart Interlock or Start Interlock operating modes
- MPCE monitoring
- Remote access to reset functions
- 2-digit numeric display for fault diagnostics
- Surface mount, lockable metal enclosure

Options

- Lid-mounted reset key switch
- Quick disconnect for incoming power and relay outputs
- Quick disconnects up to 6 mat zone inputs
- Solid-state safety output module
- Safety relay output module

Description

MC3

The MC3 DIN mount controller may be used in applications that do not require the feature set of the MC6 controller. The MC3 single zone mat controller has removable terminal blocks and operates only on 24 VDC.

MC4

The MC4 is a NEMA 4, 12 rated single zone mat controller. This controller may be used in applications when the diagnostic features of the MC6 may not be required. The MC4 may be ordered in either 24 VDC or the universal auto-selecting power supply for 100-240 VAC.

MC6

The MC6 is a NEMA 4, 12 controller with six individual mat zone indicators and is designed to be backward compatible with the MC4. Both units are dimensionally identical. This is where the similarities stop: The MC6 has full featured diagnostics with a 24 VDC and an optional universal power supply (100-240 VAC auto-selecting). It is a controller that can be used anywhere in the world.

Additional Guarding Requirements

A safety mat system is often only one part of a machine guarding solution. If the safety mat does not protect all access to the point of operation, additional guarding must be used. Safety mat systems should only be used to detect the presence, not the absence, of a force.

Perimeter Guarding Requirements

For perimeter guarding installations, the guarded machine or robot controller must be wired such that any stop signal generated by the safety mat system will cause an immediate stop of the hazardous motion. The machine or robot must only be restarted by the actuation of a manual reset switch. This reset switch must be located outside the area of hazardous motion and positioned such that the hazardous area can be observed by the switch operator. The purpose of this arrangement is to prevent a machine or robot from automatically restarting once the sensing weight is no longer detected by the safety mat sensing area.



F

Specifications

Controller Specifications	MC3	MC4	MC6
Performance			
Category 3 Safety Device:	Yes		
Max Input Resistance:	8 ohm per input channel		
Response Time:	< 30 msec		
Indications:	1 - Green = Run 1 - Red = Stop 1 - Green = Mat Clear		1 - 2 Digit Diagnostic Display 1 - Green = Run 1 - Red = Stop 1 - Green = Mat Clear 1 - Yellow = Interlock 6 - Red = Mat Zones
Operational Modes: (Selectable)	Automatic Start, Start/Restart Interlock		DIP Switch Selected, Automatic Start, Start/Restart Interlock Start Interlock
Electrical			
Power Input:	24 VDC ± 15% < 3 watts	24 VDC ± 10% < 3 watts or Autoselecting, 100 - 240 VAC ± 10%, 20 watts	24 VDC ± 10% 10 watts (Relay), 24 VDC ± 10% 50 watts (Solid-State), or Autoselecting, 100 - 240 VAC ± 10%, 20 watts
Safety Inputs:	One - 4-wire UM Safety Mat, or group series as one input. Approximately 12 multiple mats may be connected to a single zone in series; Do not exceed 8 ohms per input channel	Connections for up to six, - 4-wire UM Safety Mats Approximately 12 multiple mats may be connected to a single zone in series Do not exceed 8 ohms per input channel	
Safety Output Relays:	2 NO and 2 NC		2 NO and 1 NC
Maximum Switched Current:	230 VAC, 6 A, 1500 watts 24 VDC - 2 A Inductive, 6 A Resistive		230 VAC, 7 A, 1600 watts 24 VDC - 2 A Inductive, 6 A Resistive
MPCE:	n/a		DIP Switch Selected
Aux. Output Relay:	None (NC may be used as Aux)		1 NO and 1 NC
Maximum Switched Current:	230 VAC, 6 A, 1500 watts 30 VDC, 1.0 A	230 VAC, 6 A, 1500 watts	125 VAC, 0.5 A
Relay Life:	Mechanical = 10M operations		
Terminal Blocks:	Removable Pressure point screw	Cage clamp terminal strip	Cage clamp terminal strip & 2-part terminal blocks
Options			
Solid-State Outputs			
Solid-State Safety Outputs:	n/a		2 Current Sourcing 24 VDC (PNP)
Maximum Switched Current:	n/a		0.625 A @ 24 VDC
Solid-State Aux. Outputs:	n/a		1 Current Sourcing (PNP) and 1 Current Sinking (NPN)
Maximum Switched Current:	n/a		Current Sourcing Max: 0.5 A @ 24 VDC Current Sinking Max: 0.1 A @ 24 VDC
Reset Function			
Key-switch (factory installed):	n/a	Yes	
Remote:	user supplied, Key-switch, or Pushbutton		
Mat Input Connectors:	n/a	Up to six quick-disconnect connectors	
Power Input and Safety Output Connector:	n/a		Yes
Enclosure:	Polycarbonate	Polyurethane-painted 14 ga. steel	
Mounting:	35 mm DIN rail	Surface Mount	
Environmental			
Protection Rating:	IP20	IP65/NEMA 4, 12	
Operating Temperature:	0 to 55°C (32 to 131° F)	0 to 55°C (32 to 131° F)	
Relative Humidity:	90%		
Vibration:	5-60 Hz at 5 g max on three axis	10-55 Hz at 5 g max on three axis	
Shock:	10 g for 0.016 sec., 1000 shocks for each axis on 3 axis		
Electromagnetic Compatibility (EMC)			
Electrostatic Discharge (ESD):	±8 kV (air discharge), ±6 kV (contact discharge)		
Radiated RF Field:	10 V/m, 80 to 1,000 MHz		
Electrical Fast Transients (EFT):	±2 kV (all power and I/O ports)		
Surge:	± 2 kV (all power and I/O ports)		
Shipping Wt.:	0.22 kg (0.8 lbs.)	Approx 4 kg (9.0 lbs.)	
Standards of Conformity:	TUV, CE, cCSAus CE Certificate # BB9910347 01 cCSAus Certificate # LR90200-14	TUV, CE, cCSAus CE Certificate # BB9910347 02 cCSAus Certificate # LR90200-14	TUV, CE, cCSAus CE Certificate # BB2110242 01 cCSAus Certificate # LR90200-14
Designed to Meet or Exceed:	EN1760-1998, EN954, ANSI/RIA15.06-1999, ANSI B11.19-2003, OSHA 1910-217C, CSA AND UL508		

Specifications are subject to change without notice.

F

Dimensions

(in./mm)

MC4, MC6

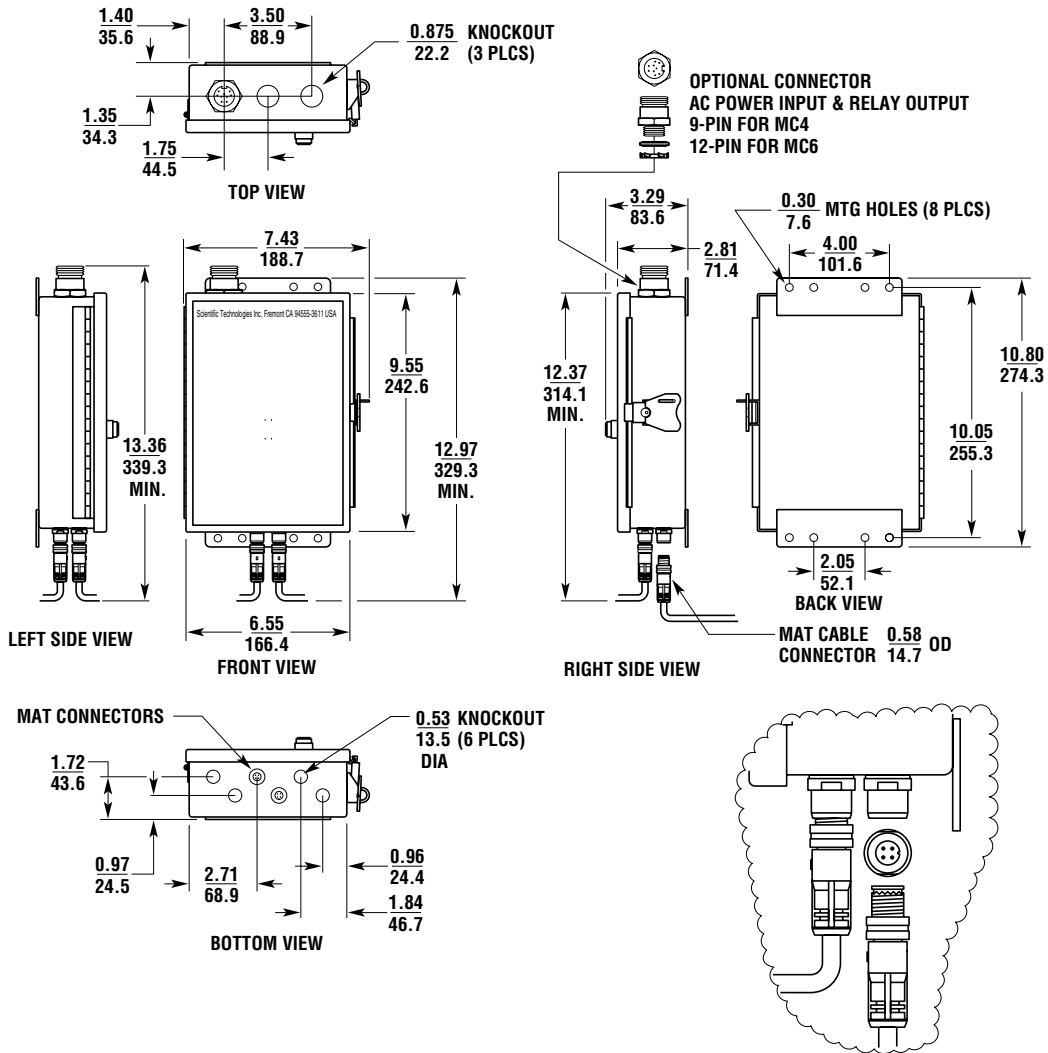

F

Dimensions (continued)

(mm/in.)

MC3

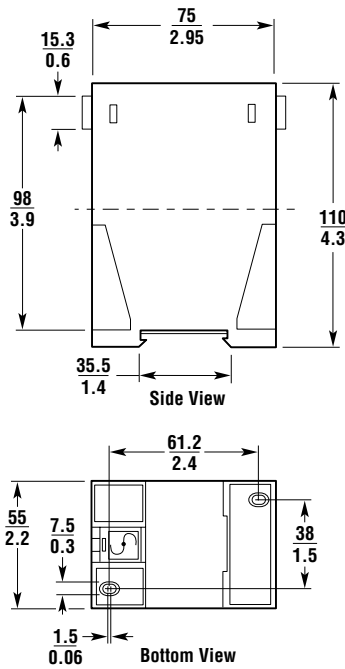

UMDB-6

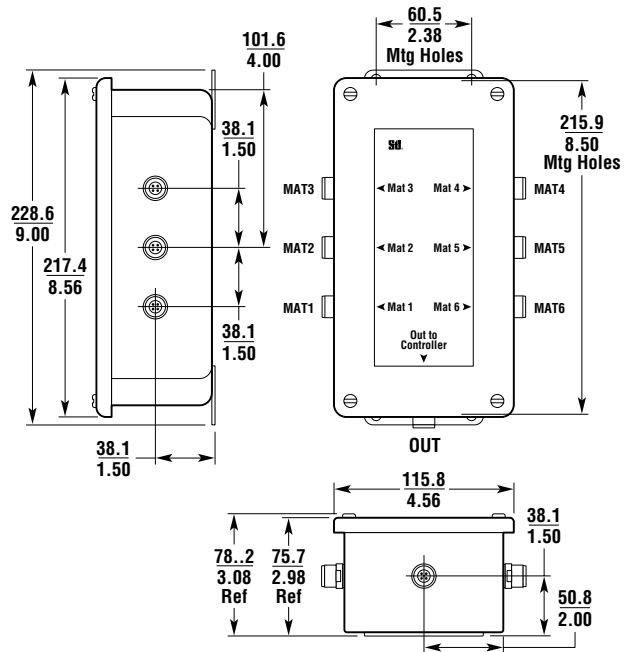

UMDB-8

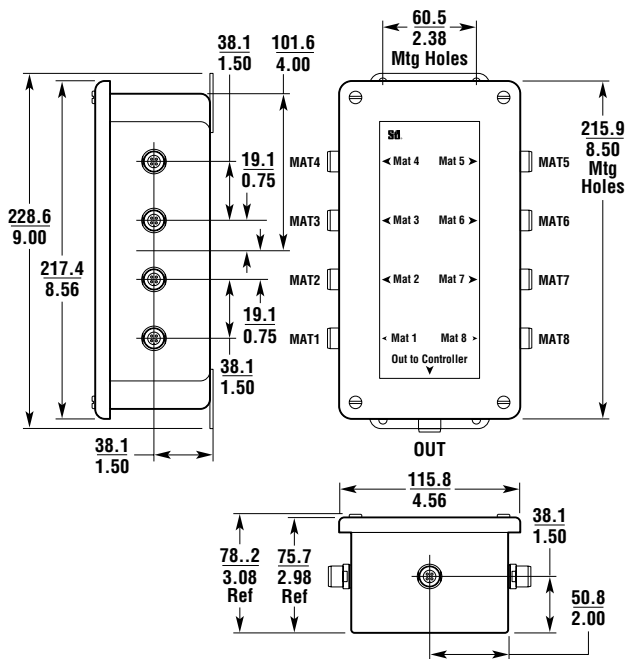

UMDB-10

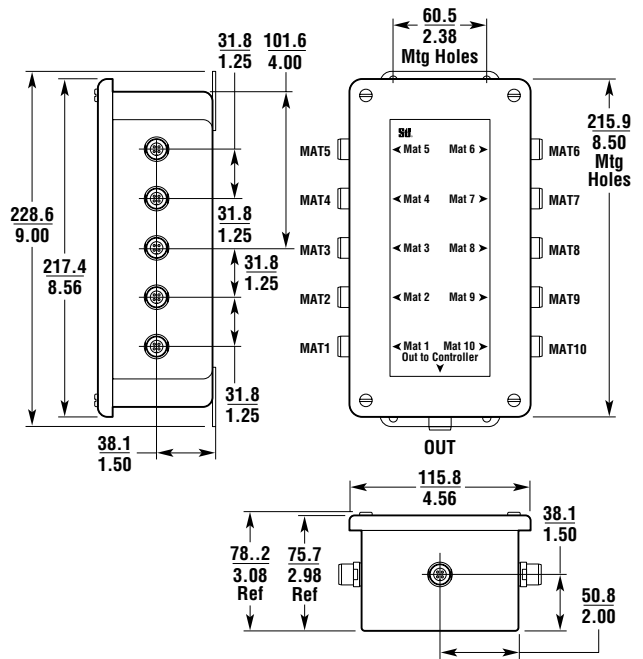

F

Wiring

MC6 with Multiple Mats Connected to One Zone

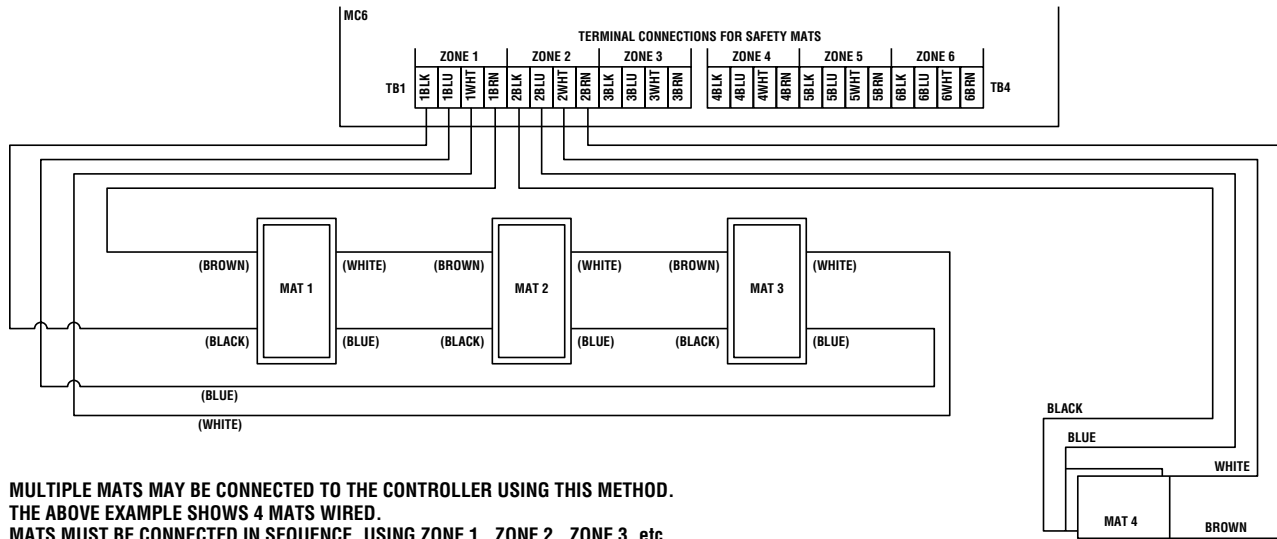

MULTIPLE MATS MAY BE CONNECTED TO THE CONTROLLER USING THIS METHOD. THE ABOVE EXAMPLE SHOWS 4 MATS WIRED. MATS MUST BE CONNECTED IN SEQUENCE, USING ZONE 1, ZONE 2, ZONE 3, etc. DIP SWITCHES MUST BE SET TO THE NUMBER OF ZONES BEING USED.

Mat Connections for Listed Controllers

- The MC4 and MC6 controllers may be ordered with up to 6 mat connectors (part #60477) installed.
- When using the MC3 controller, part #60477 may be ordered for mounting in customer enclosure.

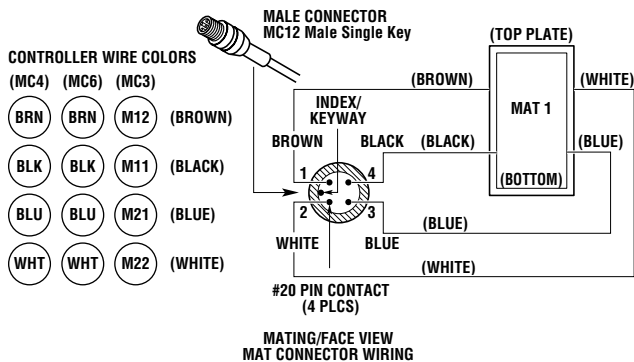

Wiring (continued)

MC4 AC Power, 9-Pin Connector

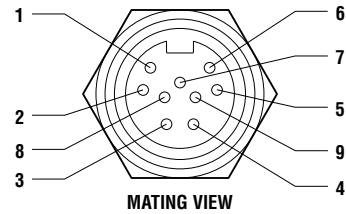
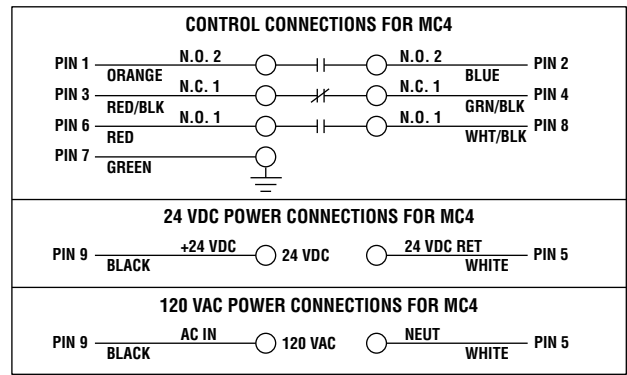
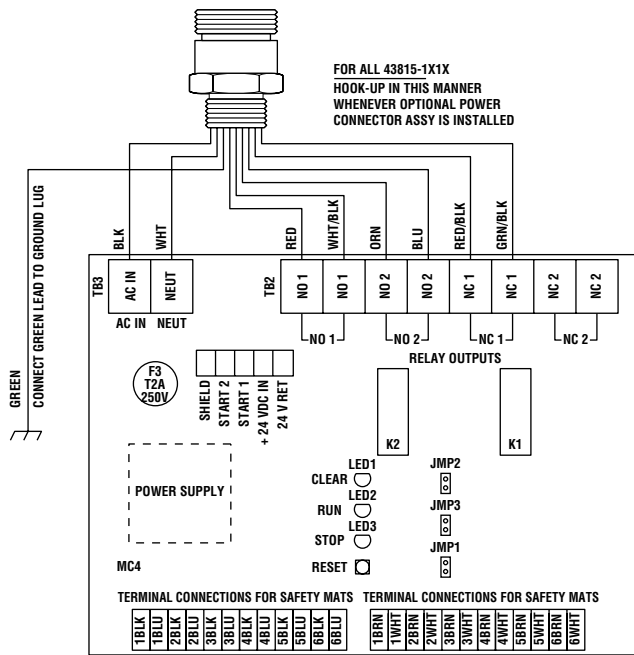

MC4 DC Power, 9-Pin Connector

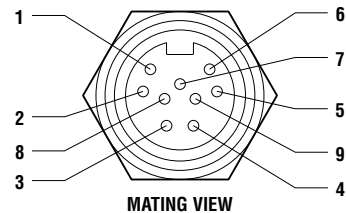
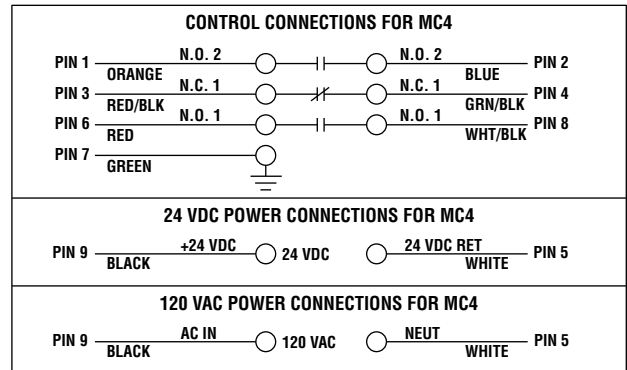
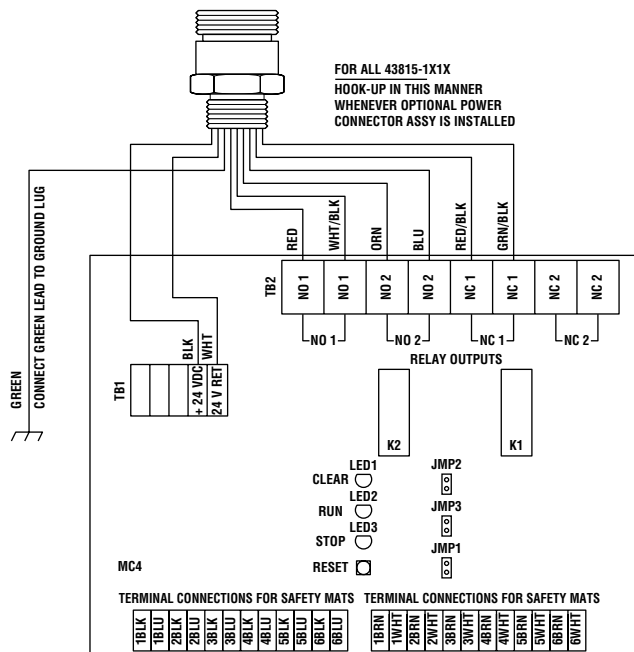

Wiring (continued)

MC6 AC Power, 12-Pin Connector

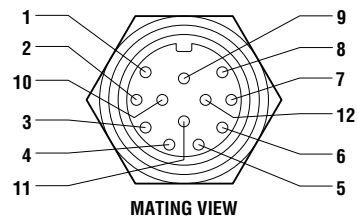
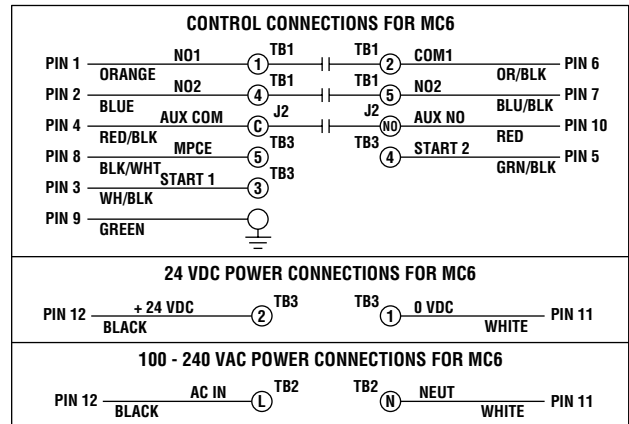
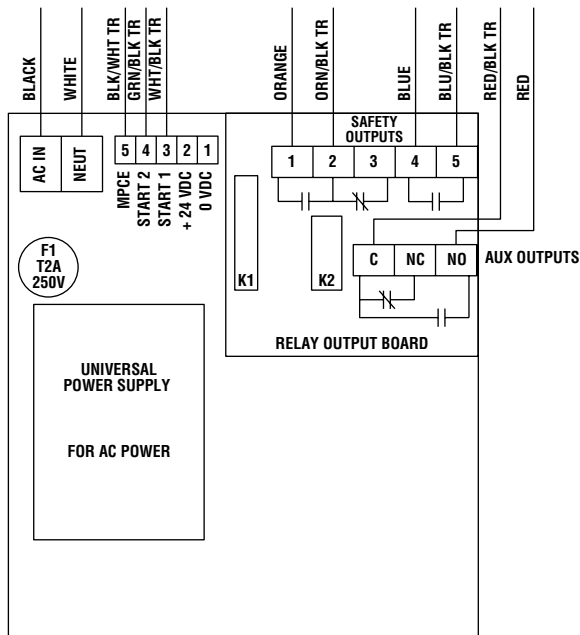

MC6 DC Power, 12-Pin Connector

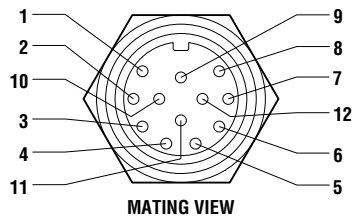
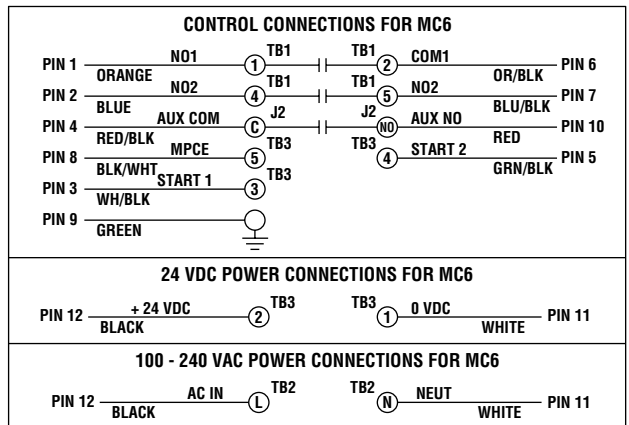
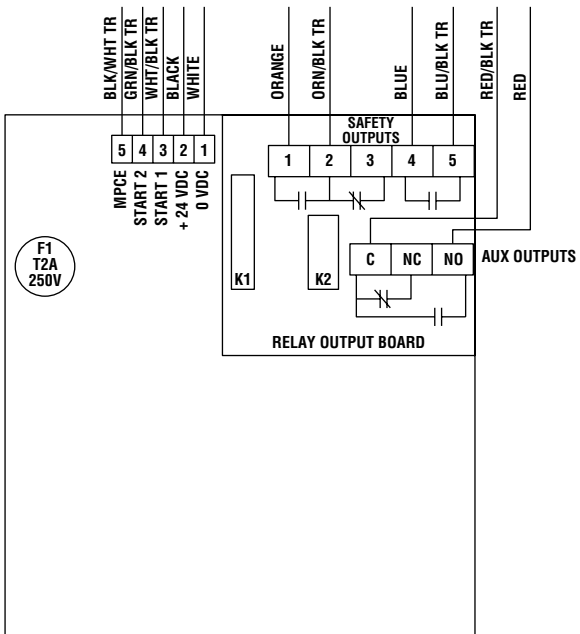

Wiring (continued)

UMDB-6

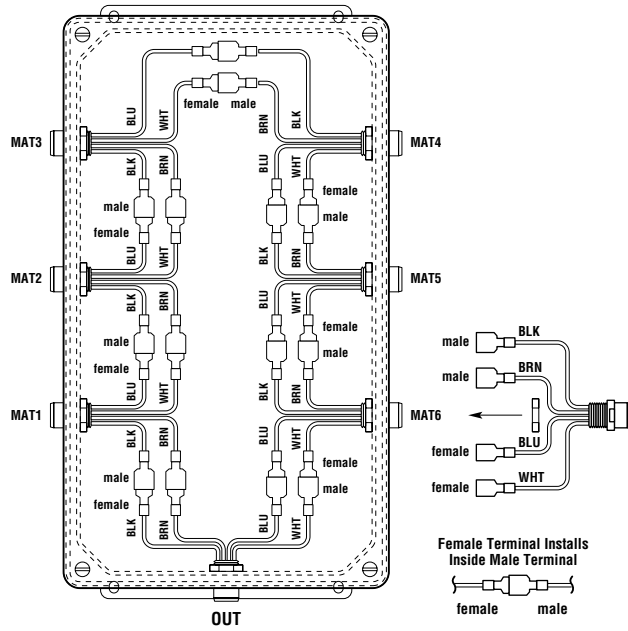

UMDB-8

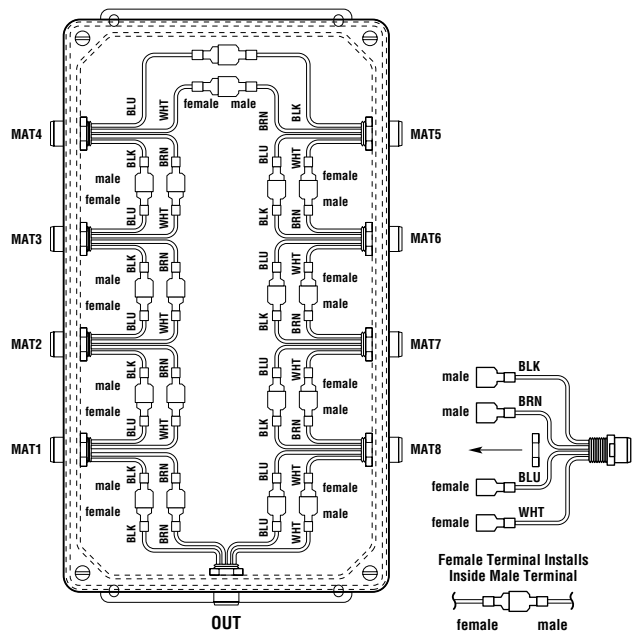

UMDB-10

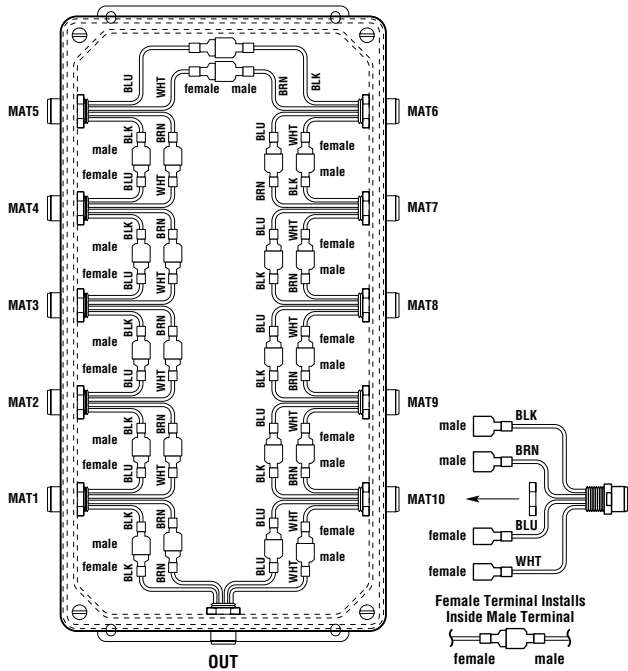

F

Suggested Machine and PLC Connections

MC3, Two Normally Open Safety Relay Outputs

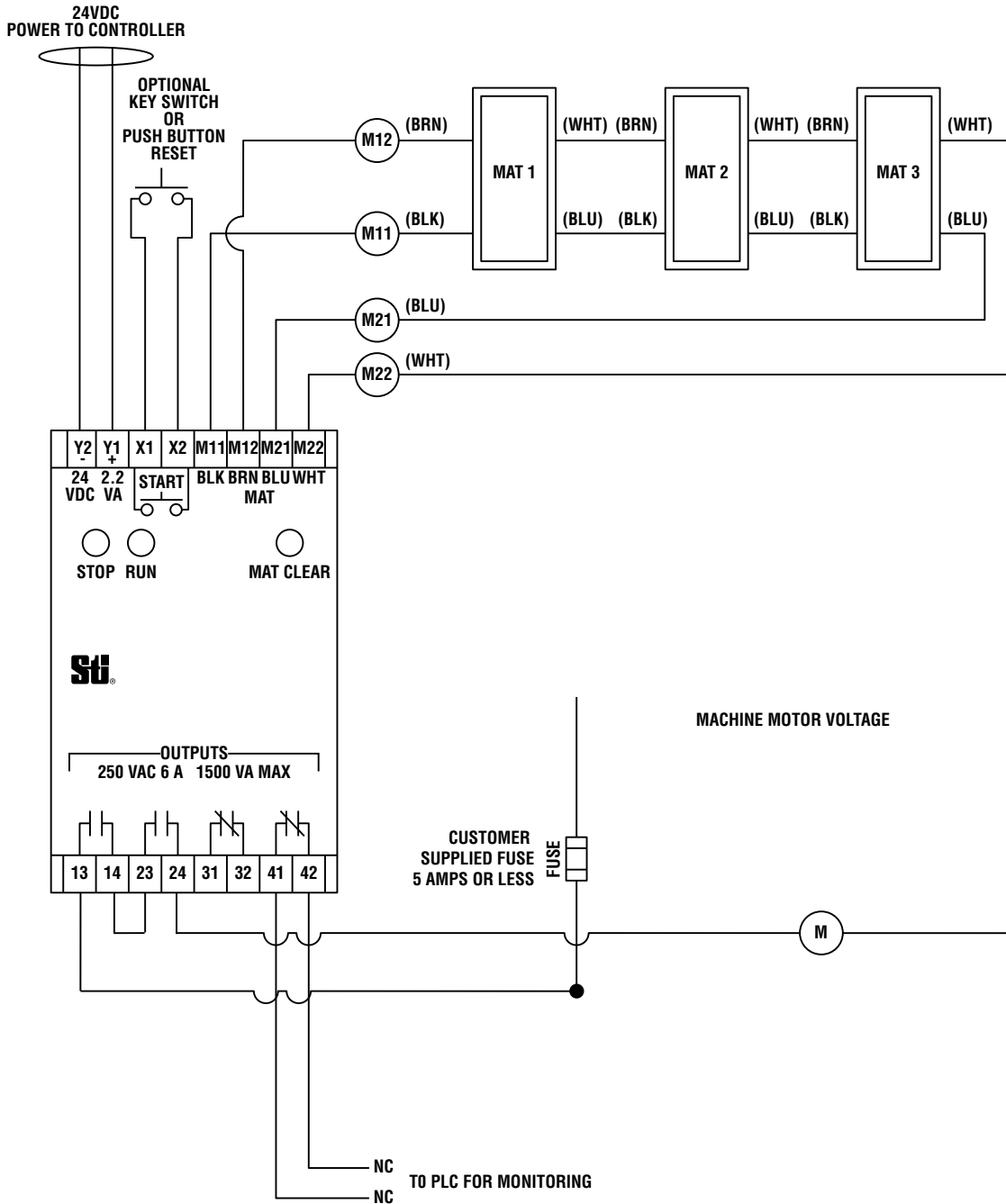

F

Suggested Machine and PLC Connections (continued)

MC4, Two Normally Open Safety Relay Outputs, 100 to 240 VAC Power

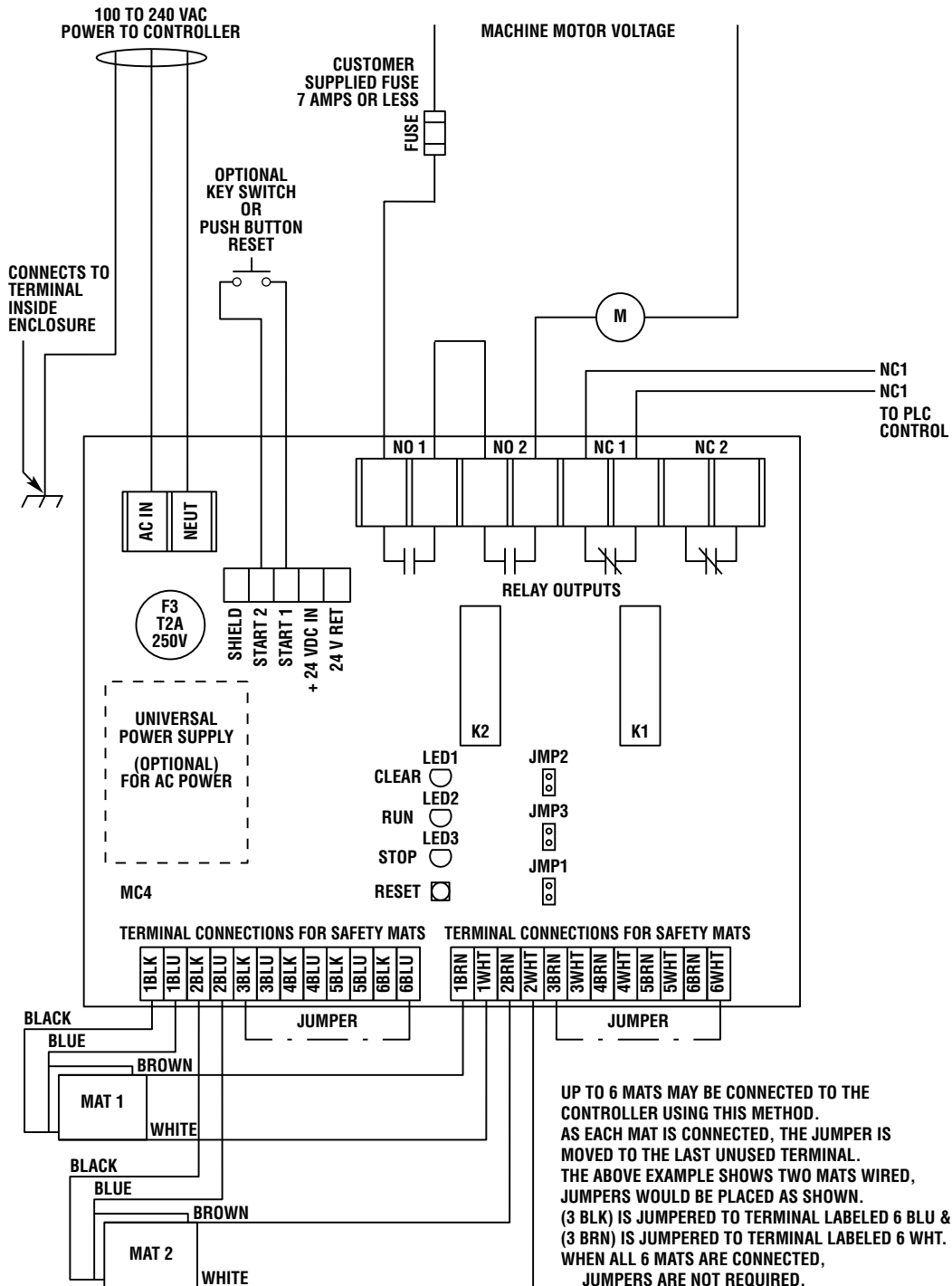

F

Suggested Machine and PLC Connections (continued)

MC4, Two Normally Open Safety Relay Outputs, 24 VDC Power

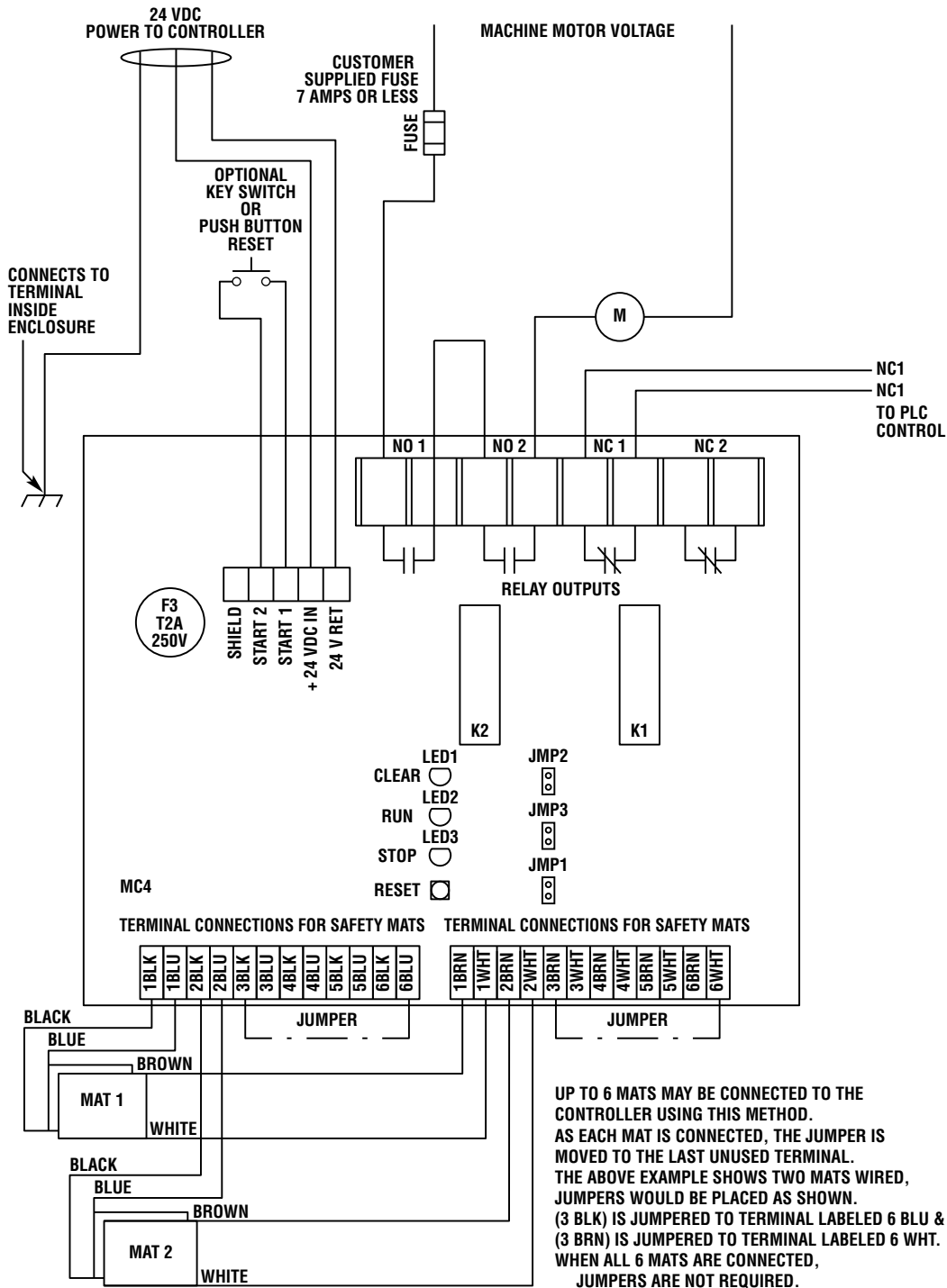

F

Suggested Machine and PLC Connections (continued)

MC6, Two Normally Open Safety Relay Outputs, 100 to 240 VAC Power

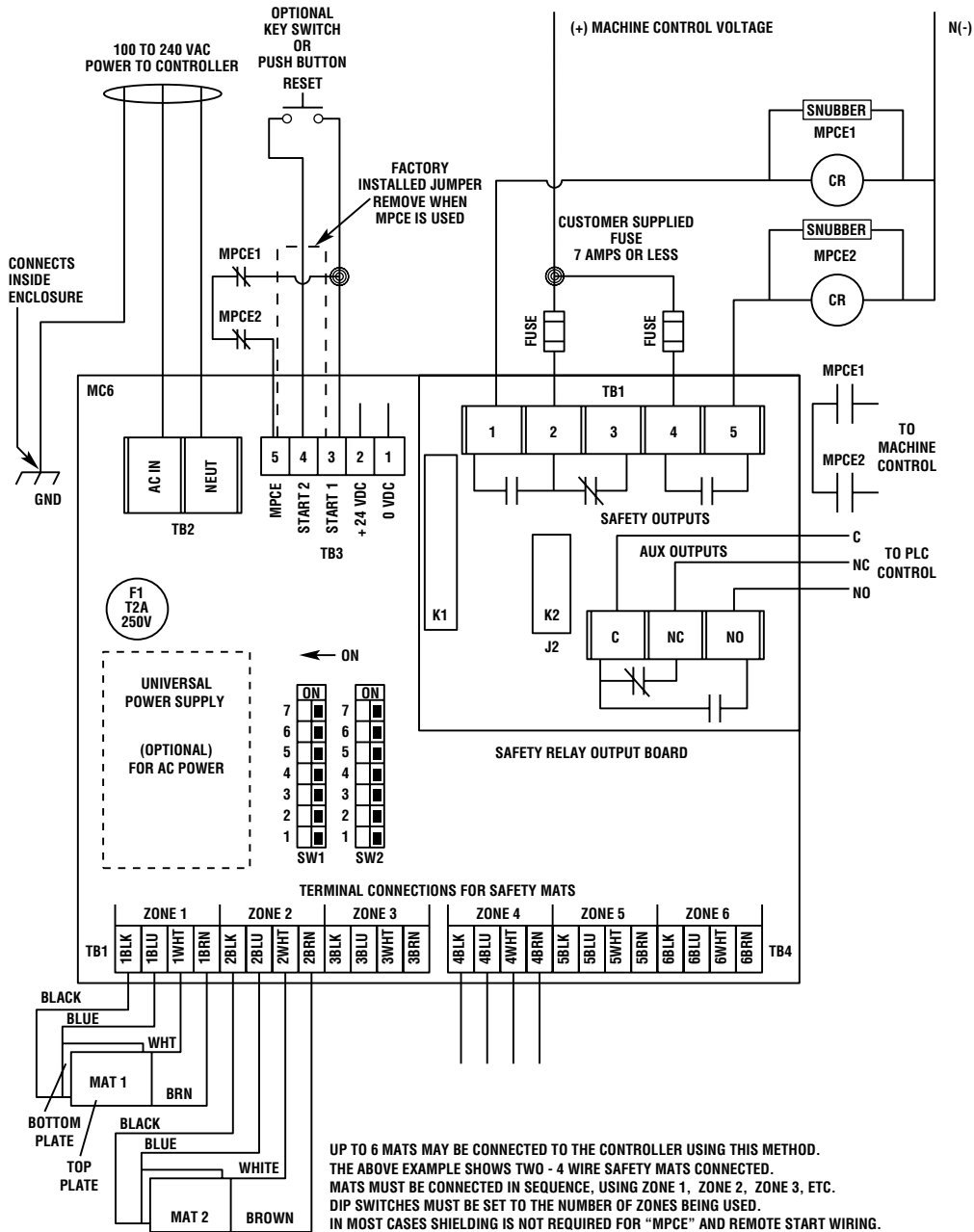

F

Suggested Machine and PLC Connections (continued)

MC6, Two Solid-State Safety Outputs, 24 VDC Power

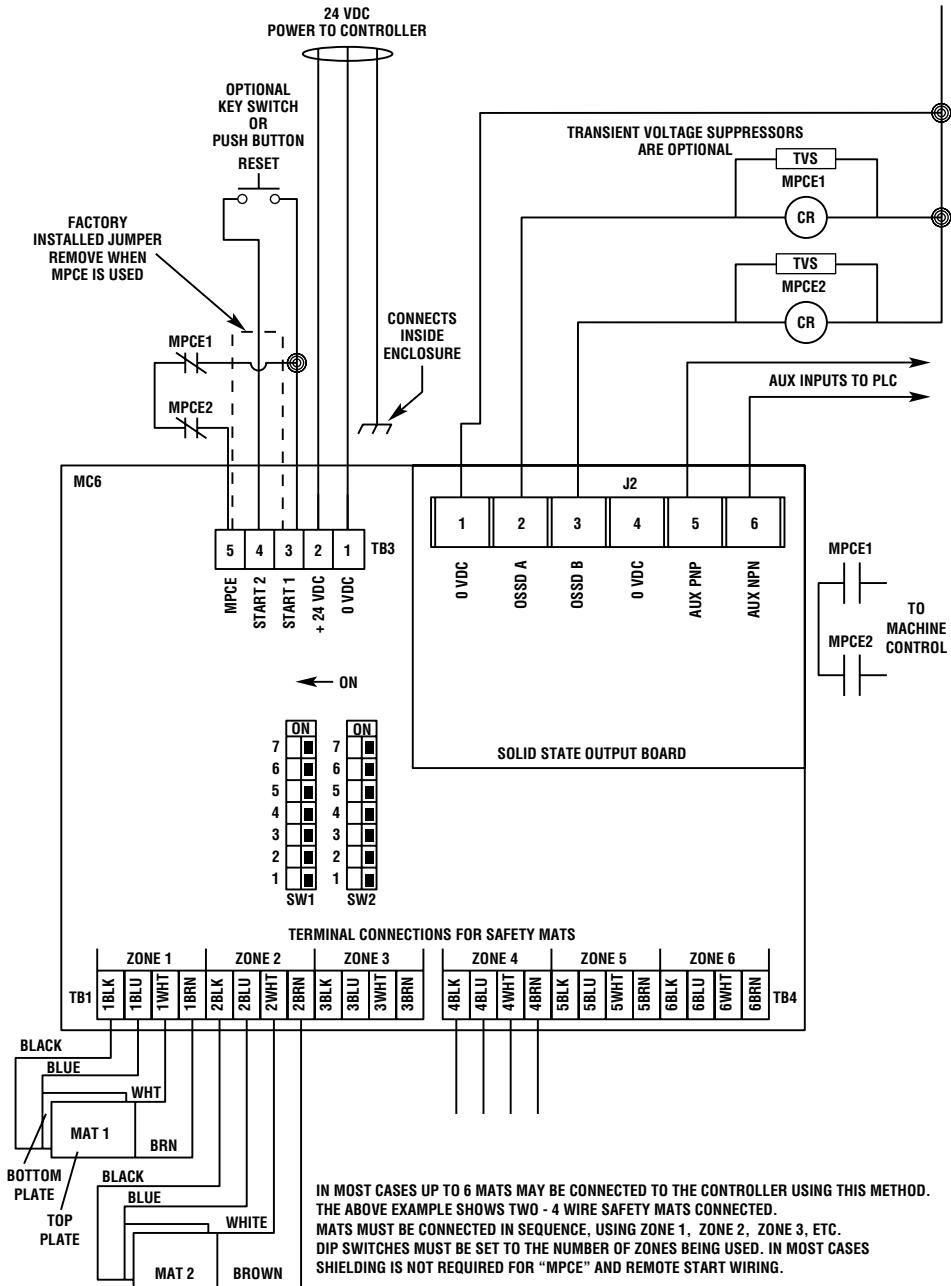

F

Ordering

MC-3



MC-4

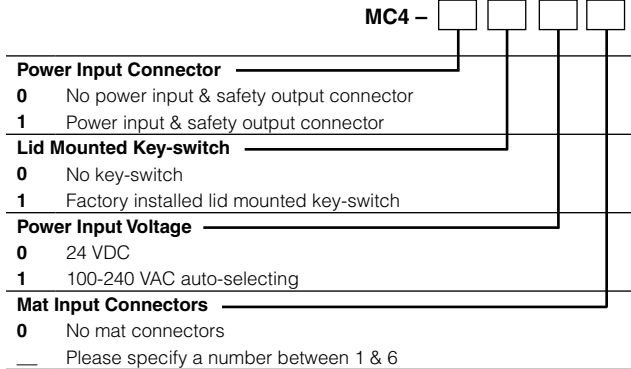

MC-6

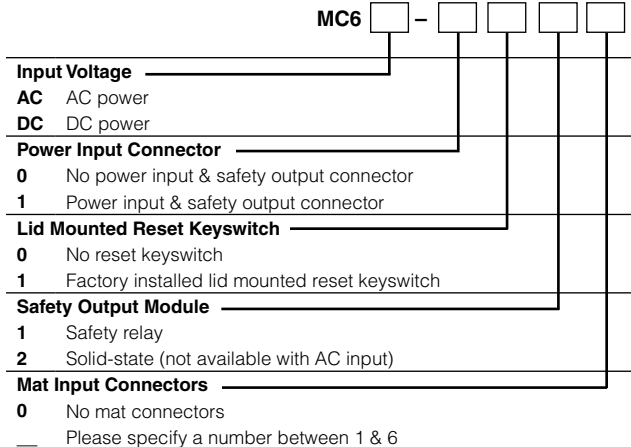

For information on Omron STI safety mats, see page F2

Rapid Delivery Products

The following models are readily available for shipment today or at least within 3 days. Please consider these for all new applications.

Model	Part Number	Description
MC3 Controller		
MC3	43767-0010	Din - 24 VDC
MC4 Controllers		
MC4-0004	43815-0004	NEMA 24, VDC, 4 mat connectors
MC4-0010	43815-0010	NEMA 24 VDC or 100-240 VAC, No connector
MC4-0011	43815-0011	NEMA 24 VDC or 100-240 VAC, 1 mat connector
MC4-0012	43815-0012	NEMA 24 VDC or 100-240 VAC, 2 mat connectors
MC4-0013	43815-0013	NEMA 24 VDC or 100-240, VAC, 3 mat connectors
MC4-0014	43815-0014	NEMA 24 VDC or 100-240, VAC, 4 mat connectors
MC6 Controllers		
MC6AC-0016	43938-0016	NEMA 24 VDC or 100-240 VAC, 6 mat connectors
MC6DC-0012	43939-0012	NEMA 24 VDC, 2 mat connectors
MC6DC-0016	43939-0016	NEMA 24 VDC, 6 mat connectors

= Highlighted **Rapid Delivery** products are available for shipment today or within **THREE** days.

Safety Standards and Precautions

A Safety Mat controller is a general purpose, safety mat control device and is not designed for any specific type, model or brand of machine. All safety-related functions of the guarded machine controls including pneumatic, electric, logic or hydraulic controls must be control reliable.

A Safety Mat controller when combined with a four-wire safety mat meets ANSI/RIA R15.06-1999, ANSI B11.19-2003 and the following applicable OSHA standards. When used with mechanical power presses, OSHA standard 1910.217(c) applies. For other applications the requirements of section 1910.212 apply.

Only use a Safety Mat controller and four-wire safety mat system on machinery that stops consistently and immediately anywhere in its cycle or stroke. Never use a Safety Mat controller and four-wire safety mat system on a full-revolution clutched press or machine. Access to the point of operation or hazardous machine area not protected by the Safety Mat controller and four-wire safety mat system must be guarded by fencing, barriers or other appropriate methods.

The purchaser, installer and employer are responsible for meeting all local state and federal government laws, rules, codes or regulations relating to the proper use, installation, operation and maintenance of this control and the guarded machine. See Installation and Operation Manual for details.

All application examples described are for illustration purposes only. Actual installations may differ from those indicated.

Компания «Life Electronics» занимается поставками электронных компонентов импортного и отечественного производства от производителей и со складов крупных дистрибьюторов Европы, Америки и Азии.

С конца 2013 года компания активно расширяет линейку поставок компонентов по направлению коаксиальный кабель, кварцевые генераторы и конденсаторы (керамические, пленочные, электролитические), за счёт заключения дистрибьюторских договоров

Мы предлагаем:

- Конкурентоспособные цены и скидки постоянным клиентам.
- Специальные условия для постоянных клиентов.
- Подбор аналогов.
- Поставку компонентов в любых объемах, удовлетворяющих вашим потребностям.
- Приемлемые сроки поставки, возможна ускоренная поставка.
- Доставку товара в любую точку России и стран СНГ.
- Комплексную поставку.
- Работу по проектам и поставку образцов.
- Формирование склада под заказчика.
- Сертификаты соответствия на поставляемую продукцию (по желанию клиента).
- Тестирование поставляемой продукции.
- Поставку компонентов, требующих военную и космическую приемку.
- Входной контроль качества.
- Наличие сертификата ISO.

В составе нашей компании организован Конструкторский отдел, призванный помогать разработчикам, и инженерам.

Конструкторский отдел помогает осуществить:

- Регистрацию проекта у производителя компонентов.
- Техническую поддержку проекта.
- Защиту от снятия компонента с производства.
- Оценку стоимости проекта по компонентам.
- Изготовление тестовой платы монтаж и пусконаладочные работы.



Тел: +7 (812) 336 43 04 (многоканальный)
Email: org@lifeelectronics.ru