

Airflow measurement using  
instrumented inlet rings.

**ebmpapst**

The engineer's choice



## About ebm-papst North America



### Headquarters - Farmington, CT

- 250,000 square feet
- 275 employees
- Contract manufacturing
- Acoustic testing chamber
- Complete air testing lab on site
- ISO 9001 and ISO 14001 certifications
- Distribution centers in Farmington, CT and Toronto, Canada

ebm-papst is an innovator and market leader in fans, blowers, and motors with core competencies in motor technology, aerodynamics, and electronics. With over 15,000 products, we provide solutions to a wide range of markets including Air-conditioning and Ventilation, Appliance, Commercial Refrigeration, Heating, Industrial, Lighting, IT / Telecom, Medical, Transportation and more.

### Support when and where you need it

Knowledgeable field sales professionals are close by for face-to-face meetings. Dedicated inside sales associates fulfill all of your ordering needs. To assist you with order management, our Customer Relations department provides automated services such as shipment notifications, reorder notifications, and invoicing.

### Design and manufacturing

Beginning with the initial product concept, our application engineers work in tandem with customers to select the best air moving solution to suit specific goals and requirements. Once the prototype has been established, it can then be tested in our state-of-the-art airflow testing chambers to optimize performance. Each chamber has been designed to meet AMCA 210 and ISO 5801 requirements. In addition to our airflow testing capabilities, ebm-papst can conduct comparative sound, temperature, and velocity tests. The electrical engineering team can design everything from simple fan controllers for monitoring fan speed to complex controllers and power supplies, filtering, and specific communication protocols.

### Logistics and inventory management programs

Our facilities feature over 90,000 square feet of climate-controlled warehousing, and utilize bar coding for real-time inventory management. Supply chain management programs such as Kanban, demand/pull, safety stock, consignment, and local warehousing can be customized to your needs.



## About ebm-papst worldwide

### Passionate about air technology and drive engineering

The ebm-papst product portfolio numbers over 15,000 products. We offer the right solution for almost every air technology and drive engineering task. In addition, we work with you to develop very customized solutions that extend beyond our current product line. This is made possible by our extensive team of over 650 dedicated engineers and technicians out of our three central locations in Germany.

### World Headquarters: Mulfingen, Germany

- ebm-papst established in 1963
- Manufacturing: Germany, Hungary, USA, Slovenia, India, China, Czech Republic and Italy
- Worldwide revenue over 1.5 billion USD
- 57 sales and distribution groups worldwide
- 11,000+ employees worldwide
- Ship over 46 million products annually
- Certifications: ISO 9001, ISO 14001 & RoHS compliant
- Over 1,000 patents held in design

### Core competencies: motor technology, aerodynamics and electronics

Our innovative technologies keep turning into new industrial standards. Our advantage: We consider aerodynamic relationships as a whole. Thus we combine benchmark-setting motor technology with the intelligence of state-of-the-art electronics and aerodynamically optimized shapes.

The system solution that results from these three core competencies has a synergy that is unique in all the world and makes up the majority of our product line.

### GreenTech® EC technology: Our motor for the future

Virtually our entire product range is now available with GreenTech, the leading edge EC technology. GreenTech EC motors deliver unparalleled energy efficiency when compared to conventional AC Technology. With wear-free and maintenance-free performance, longer service life, lower noise, intelligent electronic control, and higher aerodynamic efficiency, GreenTech EC motors from ebm-papst are the future of air moving technology.

### Passion, quality and responsibility: Three reasons for our success

Only real passion for fans and motors makes the highest level of achievement possible. With a clear organizational structure, flat hierarchies and a high degree of personal responsibility, we create the perfect foundation - not only for technological innovation, but also for excellent service and active dedication to closely working with our customers.

Of course, our products are also produced with the highest quality - at a total of 17 facilities worldwide. Our quality management is uncompromising and is present in every process stage. This is also confirmed by our certification of compliance with the international standards ISO 9001, ISO/TS 16949 and the standard ISO 14001.



**The symbol of our commitment**

GreenTech is a name put to the philosophy ebm-papst has used for decades: "each new product that we develop has to be better than its predecessor in terms of economy and ecology." Our company philosophy is not just for designing new and more efficient fans and blowers; it is in practice in the offices and factories, locally and internationally. At the U.S. headquarters, two separate arrays of solar panels have been installed to provide the engineering building with electricity, along with additional renovations that make the facilities even more environmentally friendly.

GreenTech symbolizes our continuous commitment, achievements, and passion to provide customers with high quality products through the use of modern development and production methods, responsible business practices and initiatives that benefit not only the user, but the environment as well.

**What is EC Technology?**

EC technology is an important factor in our GreenTech philosophy. ebm-papst EC fans use permanent magnet external rotor DC motors with fully integrated electronic commutation (EC) and AC to DC power conversion. EC motors give the flexibility of connecting to AC mains with the efficiency and simple speed control of a DC motor. With EC fans, the user benefits from the innovative commutation without wear-and-tear on the motor. The EC motor compares to the direct current shunt-wound motor except that the magnetic field is generated by permanent magnets inside the rotor.

With this technology, EC motors and fans can be easily controlled, are maintenance-free, offer outstanding efficiency and have a considerably long service life. The variable speed range possible in EC technology makes using a multitude of individual models a thing of the past.

Our R&D efforts are not only focused on saving energy. In terms of air performance and low noise, our products exceed the toughest specifications. EC technology pays off for every owner or operator, while conserving precious energy resources. When you use intelligent ebm-papst EC technology in your applications, everyone wins - companies, customers, and the environment.



**Airflow measurement using instrumented inlet rings**

ebm-papst offers a simple airflow measurement technique for backward-curved centrifugal fans using modified versions of inlet rings (IR) typically used with these fans to maximize performance. The technique is based on the Bernoulli and Continuity equations, which allow calculation of flow through a converging nozzle based upon measurement of the static pressure drop across the nozzle.

The application is of the form  $Q = 9.29k \cdot \sqrt{\rho_s / \rho \cdot \Delta P}$ , where:

Q = airflow in CFM

k = nozzle calibration factor

$\Delta P$  = static pressure drop across the nozzle in inches H<sub>2</sub>O

$\rho_s$  = standard air density of .075 lbs/ft<sup>3</sup>

$\rho$  = actual air density in lbs/ft<sup>3</sup>

The calibration factor "k" has been empirically determined for each IR at standard air density of .075 lbs/ft<sup>3</sup>. Large variations from this air density can effect the measurement and can be taken into account using the  $\rho_s / \rho$  ration, otherwise this term can be dropped from the equation.

Two types of instrumented inlet rings are available for each impeller size. One type uses a single pressure tap positioned near the discharge end of the IR. The 2nd type uses four pressure taps spaced along the circumference of the IR, connected with tubing to form a piezometer ring. The piezometer ring averages the static pressure measurements around the circumference of the IR to provide a more accurate flow measurement in case of uneven pressure distribution around the inlet. In either case, the customer connection on the inlet ring is to a single pre-mounted tube connector, suitable for pneumatic tubing with an internal diameter of 4 mm. This connection should run to the low pressure side of a differential pressure transducer (DPT), while the pressure tap in front of the IR is connected to the high pressure side of the DPT. If the DPT is mounted near the front of the IR but out of the airstream, then the high pressure tap on the DPT is suitable and no additional pressure tap is needed.

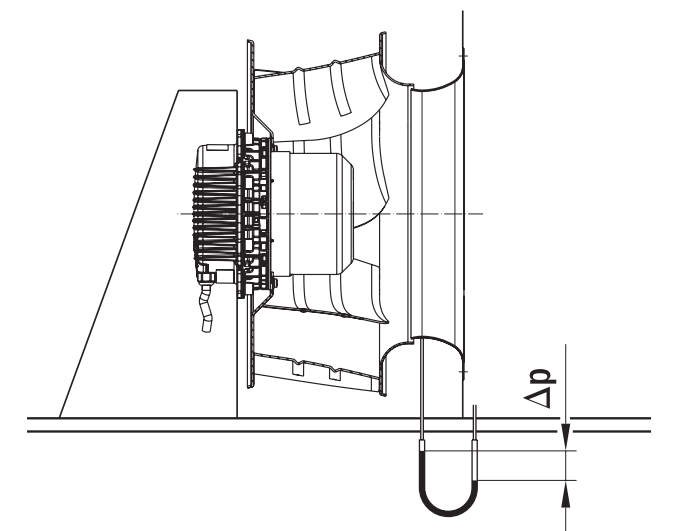



## Inlet Ring Part Numbers

### Inlet Ring Part Numbers

Find the proper instrumented inlet ring P/N based on the impeller size and type (e.g., 3D EC). Choose the P/N for either the inlet ring with a single pressure tap or for the version with multiple taps connected in a piezometer ring. In cases where there are multiple listings for a single impeller size, please discuss the choice of the correct inlet ring with an ebm-papst applications engineer.



#### Inlet Rings

Size (mm)	Impeller & fan type	Part no. w/o pressure tap (for dimensional reference only)	Part no. with 1 pressure tap	Part no. with piezometer ring	k-value
250	2D AC/EC	96359-2-4013	<b>25002-2-4013</b>	<b>25001-2-4013</b>	69
250	2D EC	25020-2-4013	<b>25040-2-4013</b>	<b>25030-2-4013</b>	67
250	2D EC + airfoil	25070-2-4013	<b>25075-2-4013</b>	<b>25080-2-4013</b>	70
280	2D AC/EC	96360-2-4013	<b>28002-2-4013</b>	<b>28001-2-4013</b>	88
280	2D EC	28020-2-4013	<b>28040-2-4013</b>	<b>28030-2-4013</b>	87
280	2D EC + airfoil	28070-2-4013	<b>28075-2-4013</b>	<b>28080-2-4013</b>	93
310	3D AC/EC	31050-2-4013	<b>31100-2-4013</b>	<b>31080-2-4013</b>	120
310	3D AC/EC	31051-2-4013	<b>31110-2-4013</b>	<b>31090-2-4013<sup>(1)</sup></b>	103
310	2D EC	31020-2-4013	<b>31060-2-4013</b>	<b>31040-2-4013</b>	108
310	2D EC	31570-2-4013	<b>31575-2-4013</b>	<b>31580-2-4013</b>	116
310	airfoil	31470-2-4013	<b>31475-2-4013</b>	—	116
355	3D AC/EC	35560-2-4013	<b>35600-2-4013</b>	<b>35580-2-4013</b>	155
355	3D AC/EC	35561-2-4013	<b>35610-2-4013<sup>(1)</sup></b>	<b>35590-2-4013<sup>(1)</sup></b>	138
355	2D EC	35520-2-4013	<b>35540-2-4013</b>	<b>35530-2-4013</b>	141
355	2D EC + airfoil	35670-2-4013	<b>35675-2-4013</b>	<b>35680-2-4013</b>	148
400	3D AC/EC + 2D AC	54476-2-4013	<b>54515-2-4013</b>	<b>54500-2-4013</b>	183
400	2D EC	40020-2-4013	<b>40040-2-4013</b>	<b>40030-2-4013</b>	161
400	2D EC + airfoil	40070-2-4013	<b>40075-2-4013</b>	<b>40080-2-4013</b>	188
450	2D AC/EC	54478-2-4013	<b>54514-2-4013</b>	<b>54510-2-4013</b>	217
450	3D AC/EC	63045-2-4013	<b>64015-2-4013</b>	<b>64005-2-4013</b>	214
450	2D EC	45020-2-4013	<b>45040-2-4013</b>	<b>45030-2-4013</b>	225
450	2D EC + airfoil	45070-2-4013	<b>45075-2-4013</b>	<b>45080-2-4013</b>	240
500	2D EC	54480-2-4013	<b>54518-2-4013</b>	<b>54516-2-4013</b>	265
500	2D EC + 3D AC/EC + airfoil	63072-2-4013	<b>64025-2-4013</b>	<b>64002-2-4013</b>	281
560	2D EC + 3D AC/EC + airfoil	63071-2-4013	<b>64030-2-4013</b>	<b>64001-2-4013</b>	348
630	3D AC/EC + airfoil	63070-2-4013	<b>64040-2-4013</b>	<b>64000-2-4013</b>	438
710	3D AC/EC + airfoil	71070-2-4013	<b>71075-2-4013</b>	<b>71080-2-4013</b>	545

Note: Subject to alterations. <sup>(1)</sup> Short inlet ring.

## Instrumented Inlet Rings

### Select Pressure Transducer Range

It's important to the accuracy of the flow measurement to select a differential pressure transducer (DPT) with a range appropriate to the expected pressure differential. It's best to choose a DPT with a range that exceeds the maximum expected pressure differential by a small safety margin. Excessive range will impact the flow measurement accuracy because the DPT accuracy is typically specified as a percent of full scale.

To find the proper pressure transducer range:

1. Determine the maximum CFM flow rate expected from the fan over its operating range as installed in the application. If this info isn't available, use the free airflow as provided in the fan specification.
2. Use Chart 1 to find the pressure differential in inches w.g. for given flow and impeller size.
3. Select a differential pressure transducer with an appropriate range based on the pressure differential determined in step 2.

Chart 1 - Pressure Differential vs Air Flow for Available Impeller Sizes

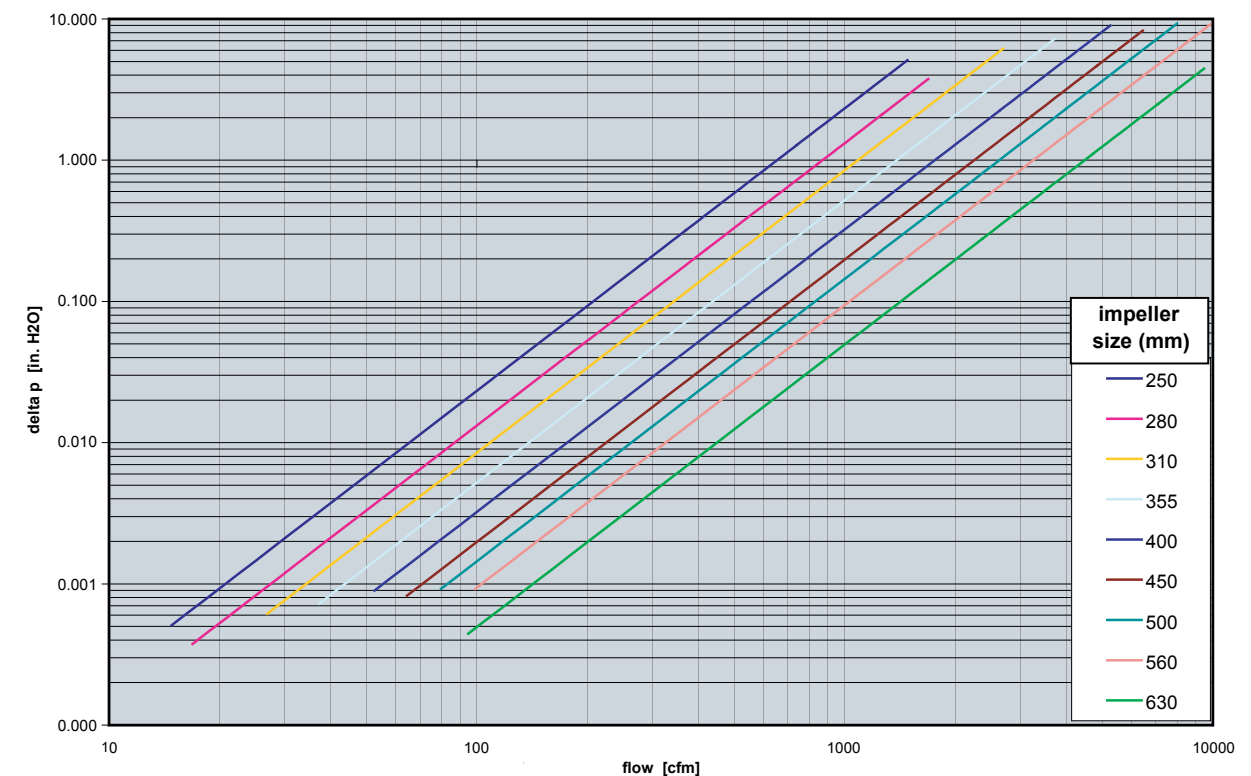

**ebm-papst Inc.**  
**North America**

100 Hyde Road  
Farmington, CT 06034  
Phone + 1 860-674-1515  
Fax + 1 860-674-8536  
sales@us.ebmpapst.com  
© ebm-papst Inc. 2016.

ebm-papst Inc. reserves the right to change any specifications or data without notice.

**ebmpapst**

The engineer's choice

Компания «Life Electronics» занимается поставками электронных компонентов импортного и отечественного производства от производителей и со складов крупных дистрибьюторов Европы, Америки и Азии.

С конца 2013 года компания активно расширяет линейку поставок компонентов по направлению коаксиальный кабель, кварцевые генераторы и конденсаторы (керамические, пленочные, электролитические), за счёт заключения дистрибьюторских договоров

Мы предлагаем:

- Конкурентоспособные цены и скидки постоянным клиентам.
- Специальные условия для постоянных клиентов.
- Подбор аналогов.
- Поставку компонентов в любых объемах, удовлетворяющих вашим потребностям.
- Приемлемые сроки поставки, возможна ускоренная поставка.
- Доставку товара в любую точку России и стран СНГ.
- Комплексную поставку.
- Работу по проектам и поставку образцов.
- Формирование склада под заказчика.
- Сертификаты соответствия на поставляемую продукцию (по желанию клиента).
- Тестирование поставляемой продукции.
- Поставку компонентов, требующих военную и космическую приемку.
- Входной контроль качества.
- Наличие сертификата ISO.

В составе нашей компании организован Конструкторский отдел, призванный помогать разработчикам, и инженерам.

Конструкторский отдел помогает осуществить:

- Регистрацию проекта у производителя компонентов.
- Техническую поддержку проекта.
- Защиту от снятия компонента с производства.
- Оценку стоимости проекта по компонентам.
- Изготовление тестовой платы монтаж и пусконаладочные работы.



Тел: +7 (812) 336 43 04 (многоканальный)  
Email: [org@lifeelectronics.ru](mailto:org@lifeelectronics.ru)