

**NEW**



# ES10 Series

CONNECTOR

MB-0274-1

January 2014

RoHS Compliant

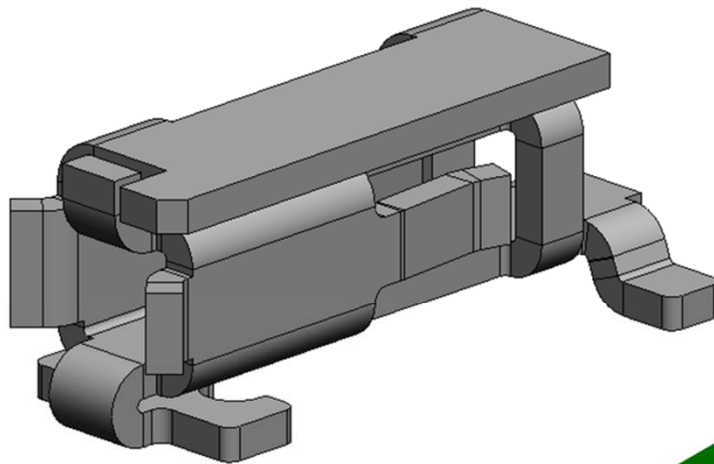

[When cable is inserted]

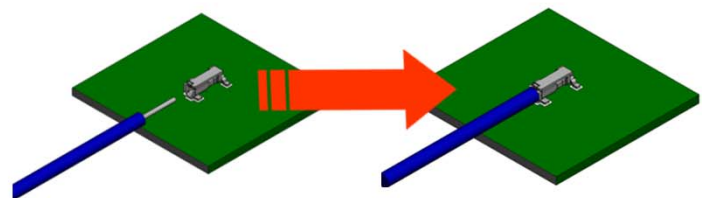

## <<Outline>>

The ES10 Series is a compact, low-profile single wire cable insertion type connector without an insulator compatible with LED lighting equipment. It can be used for a wide range of various compact devices such as liquid crystal TV backlight, tablet PC, and others.

## Features

- Compact and low-profile structure without an insulator enhances design flexibility for customers.
- Just need to insert the stripped wire into the connector for connection.
- Improved insertion workability with a guiding mechanism at the single wire insertion area.
- Improved contact reliability with an original spring contacting structure.
- Available in embossed tape reel packaging for automated mounting.

## General Specifications

- |                                 |  |
|---------------------------------|--|
| ■ No. of Contacts: 1 pin        | ■ Durability: 5 times  |
| ■ Contact Resistance: 30mΩ max. | ■ Operating Temperature:<br>-40 Deg. C to +105 Deg. C  |
| ■ Rated Current: AC/DC 2A       | ■ Applicable Wire:<br>Single wire 26 to 24 AWG equivalent<br>(φ0.4mm to φ0.51mm)<br>Covered diameter φ2.0mm max. (recommended) |

\* twisted wire (including spare solder) can not be used

Materials and Finishes

| Component | Material and Finish       |
|-----------|---------------------------|
| Contact   | Copper alloy / Sn plating |

Ordering Information

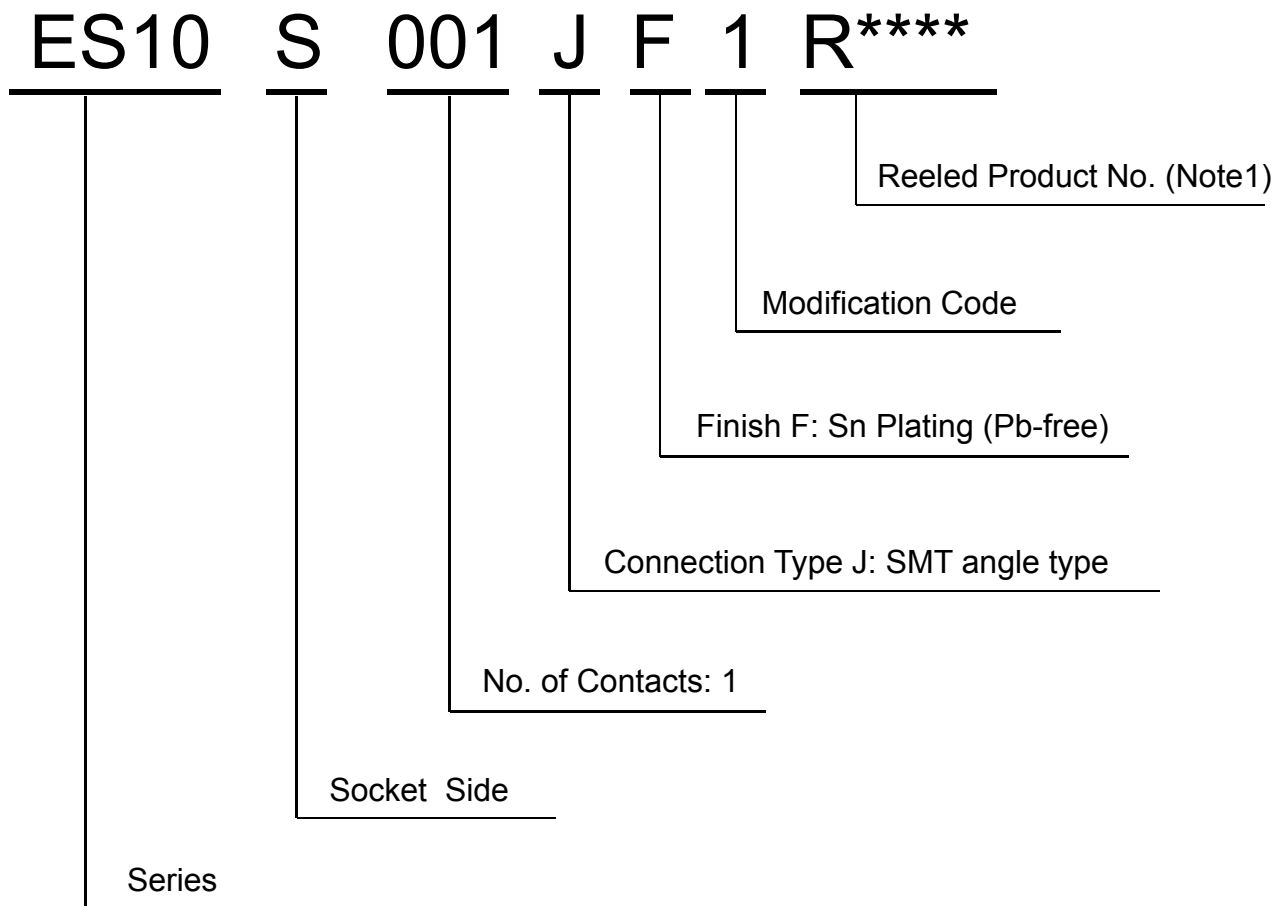

Note 1: An embossed tape reel contains 4,500 pieces.

|             |             |
|-------------|-------------|
| Part Number | ES10S001JF1 |
| Drawing No. | SJ113985    |

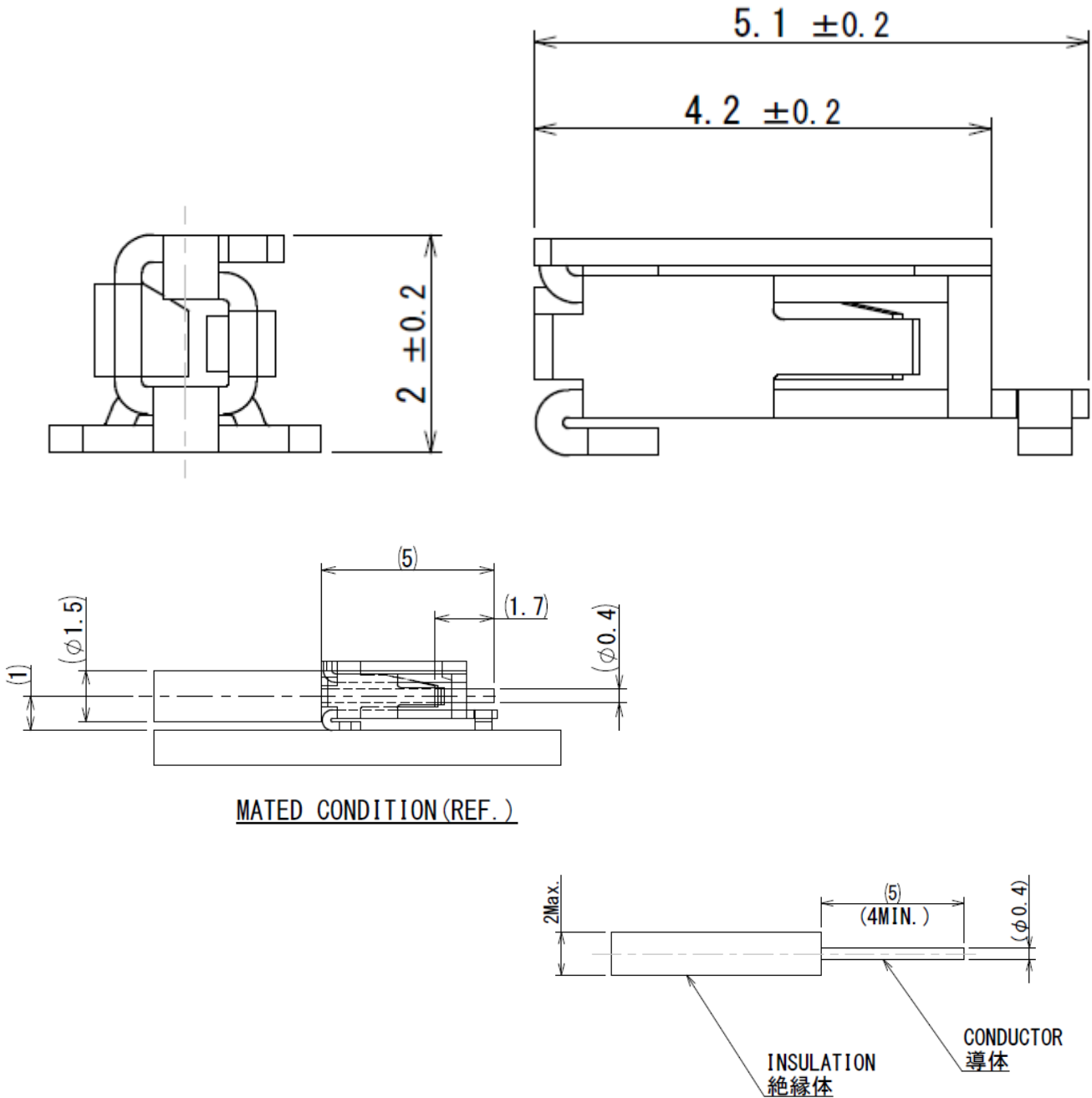

Note 1: Applicable cable (conductor): single wire 26AWG (0.4 Dia.)  
 Applicable cable (insulator): 2.0 Dia. max. \*Please contact us regarding other sizes.  
 Note 2: Twisted wire can not be used.

|        |                |         |              |                       |
|--------|----------------|---------|--------------|-----------------------|
| 1      | CONNECTOR      | 1       | COPPER ALLOY | LEAD-FREE TIN PLATING |
| 符号 NO. | 名称 DESCRIPTION | 個数 QTY. | 材料 MATERIAL  | 仕上 FINISH             |

|             |                  |
|-------------|------------------|
| Part Number | ES10S001JF1R4500 |
| Drawing No. | SJ113986         |

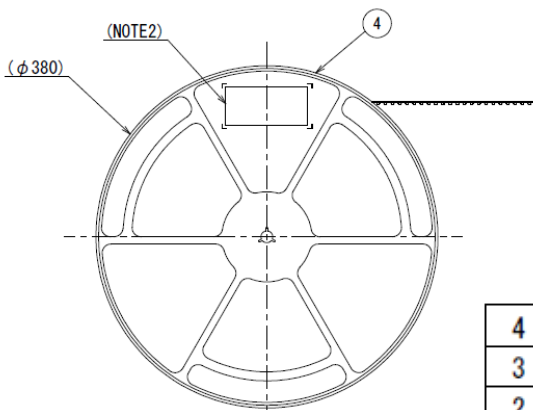
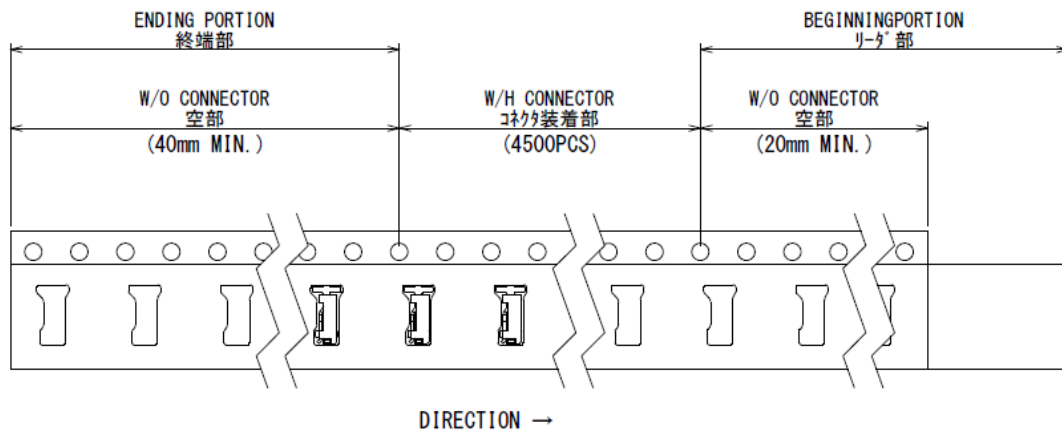
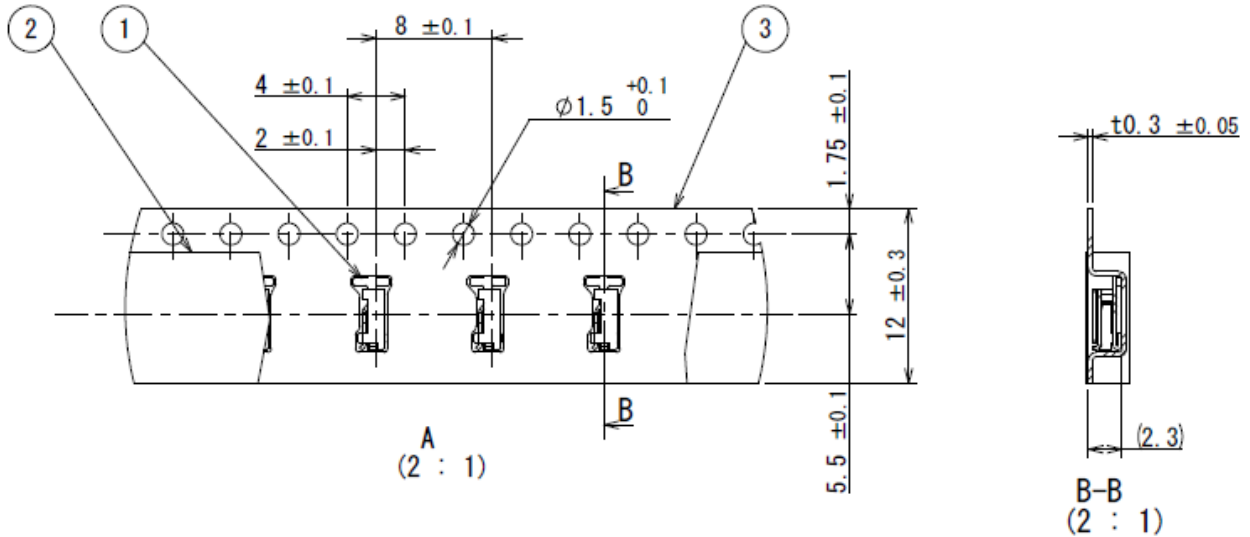

|           |                    |             |                 |
|-----------|--------------------|-------------|-----------------|
| 4         | REEL               | 1           | POLYSTYRENE     |
| 3         | CARRIER TAPE       | 1           | POLYSTYRENE     |
| 2         | COVER TAPE         | 1           | POLYESTER       |
| 1         | CONNECTOR          | 4500        |                 |
| 符号<br>NO. | 名 称<br>DESCRIPTION | 個 数<br>QTY. | 材 料<br>MATERIAL |

## <Applicable Board Dimensions>

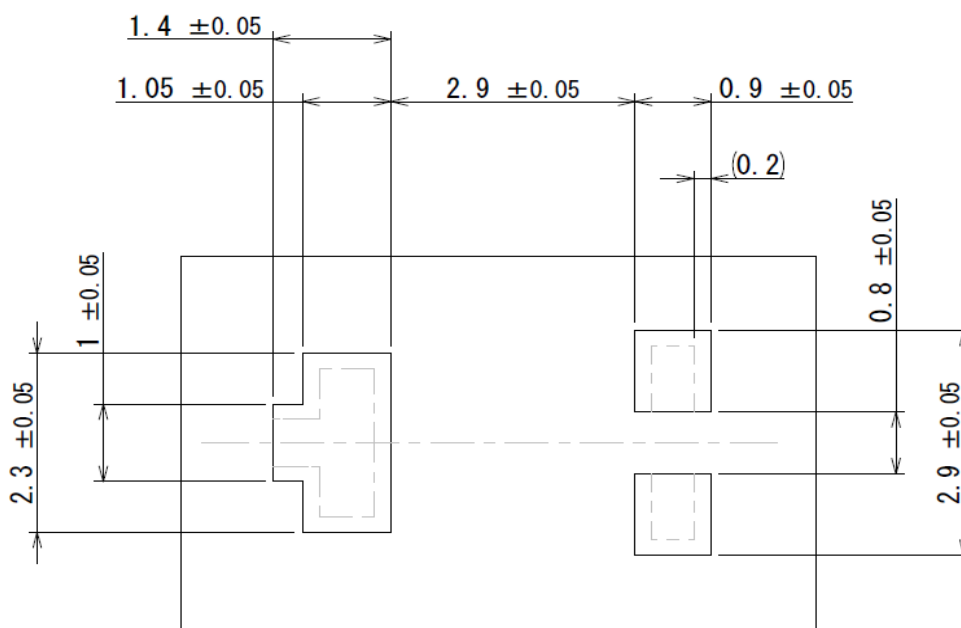

### Technical Documents

|                       | Technical Document No. (Content of documents)  |
|-----------------------|--|
| Product Drawings      | SJ113985 (ES10S001JF1 individual product)<br>SJ113986 (ES10S001JF1 embossed packaging product) |
| Specifications        | JACS-10984   |
| Handling Instructions | JAHL-10984   |

#### Notice:

1. The values specified in this brochure are only for reference. The products and their specifications are subject to change without notice. Contact our sales staff for further information before considering or ordering any of our products. For purchase, a product specification must be agreed upon.

2. Users are requested to provide protection circuits and redundancy circuits to ensure safety of the equipment, and sufficiently review the suitability of JAE's products to the equipment.

3. The products presented in this brochure are designed for the uses recommended below. We strongly suggest you contact our sales staff when considering use of any of the products in any other way than the recommended applications or for a specific use that requires an extremely high reliability.

(1) Applications that require consultation:

(i) Please contact us if you are considering use involving a quality assurance program that you specify or that is peculiar to the industry, such as:

Automotive electrical components, train control, telecommunications devices (mainline), traffic light control, electric power, combustion control, fire prevention or security systems, disaster prevention equipment, etc.

(ii) We may separately give you our support with a quality assurance program that you specify, when you think of a use such as :

Aviation or space equipment, submarine repeaters, nuclear power control systems, medical equipment for life support, etc.

(2) Recommended applications include:

Computers, office appliances, telecommunications devices (terminals, mobile units), measuring equipment, audiovisual equipment, home electric appliances, factory automation equipment, etc

### **Japan Aviation Electronics Industry, Limited**

Product Marketing Division

Aobadai Building, 3-1-19, Aobadai, Meguro-ku, Tokyo 153-8539

Phone: +81-3-3780-2882 FAX: +81-3-3780-2946

\* The specifications in this brochure are subject to change without notice. Please contact JAE for information.

Компания «Life Electronics» занимается поставками электронных компонентов импортного и отечественного производства от производителей и со складов крупных дистрибьюторов Европы, Америки и Азии.

С конца 2013 года компания активно расширяет линейку поставок компонентов по направлению коаксиальный кабель, кварцевые генераторы и конденсаторы (керамические, пленочные, электролитические), за счёт заключения дистрибьюторских договоров

Мы предлагаем:

- Конкуренспособные цены и скидки постоянным клиентам.
- Специальные условия для постоянных клиентов.
- Подбор аналогов.
- Поставку компонентов в любых объемах, удовлетворяющих вашим потребностям.
- Приемлемые сроки поставки, возможна ускоренная поставка.
- Доставку товара в любую точку России и стран СНГ.
- Комплексную поставку.
- Работу по проектам и поставку образцов.
- Формирование склада под заказчика.
- Сертификаты соответствия на поставляемую продукцию (по желанию клиента).
- Тестирование поставляемой продукции.
- Поставку компонентов, требующих военную и космическую приемку.
- Входной контроль качества.
- Наличие сертификата ISO.

В составе нашей компании организован Конструкторский отдел, призванный помогать разработчикам, и инженерам.

Конструкторский отдел помогает осуществить:

- Регистрацию проекта у производителя компонентов.
- Техническую поддержку проекта.
- Защиту от снятия компонента с производства.
- Оценку стоимости проекта по компонентам.
- Изготовление тестовой платы монтаж и пусконаладочные работы.



Тел: +7 (812) 336 43 04 (многоканальный)

Email: [org@lifeelectronics.ru](mailto:org@lifeelectronics.ru)