

Specification

(Reference)

Title: FIXED CHIP RESISTOR NETWORKS; RECTANGULAR TYPE

Style: RAC10 2D,RAC10 4D,RAC16 4D, RAC16 8D

RoHS COMPLIANCE ITEM

Product specification contained in this specification
are subject to change at any time without notice
If you have any questions or a Purchasing Specification for any quality
Agreement is necessary, please contact our sales staff.



釜屋電機株式會社
KAMAYA ELECTRIC CO., LTD.

Issue Dept.: Research & Development Department Hokkaido Research Center

1. Scope

1.1 This specification covers the detail requirements for fixed chip resistors networks; rectangular type, style of RAC10 2D,10 4D,16 4D, 16 8D.

1.2 Applicable documents

- JIS C 5201-1: 1998, JIS C 5201-9: 2006, JIS C 5201-9-1: 2006
- IEC60115-1: 1999, IEC60115-9: 2003, IEC60115-9-1: 2003
- EIAJ RC-2129-2000.

2. Classification

Type designation shall be the following form.

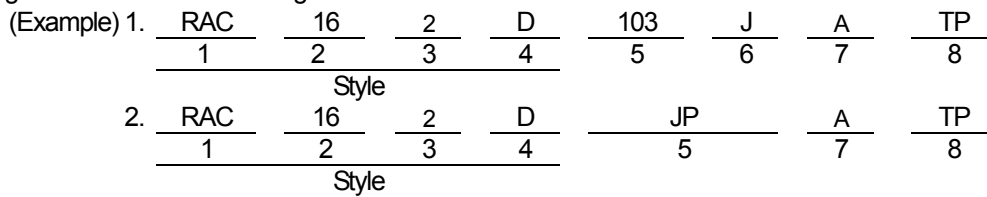

- 1 Fixed chip resistors networks; rectangular type
- 2 Size
- 3 Number of element
- 4 Circuits
- 5 Rated resistance Example; 103 → 10kΩ, Chip jumper: JP
- 6 Tolerance on rated resistance
- 7 Terminal style
- 8 Packaging form 1. Scope

3. Rating

3.1 The ratings shall be in accordance with Table-1.

Table-1

| Style | | Terminations style | Rated element dissipation (W) | Rated network dissipation (W) | Temperature coefficient of resistance (10 ⁻⁶ /°C) | Rated resistance range(Ω) | Preferred number series for resistors | Tolerance on rated resistance |
|-------|----|--------------------|-------------------------------|-------------------------------|--|---------------------------|---------------------------------------|-------------------------------|
| RAC10 | 2D | C | 0.063 | 0.125 | ±200 | 10~1.0M | E24 | J(±5%) |
| | 4D | | | | | | | |
| RAC16 | 4D | C | 0.063 | 0.25 | ±200 | 10~1.0M | E24 | F(±1%) J(±5%) |
| | 8D | | | | | | | |

| Style | | Limiting element voltage(V) | Isolation voltage(V) | Number of element | Circuit networks | Category temperature range(°C) |
|-------|----|-----------------------------|----------------------|-------------------|--------------------------|--------------------------------|
| RAC10 | 2D | 25 | 50 | 2 | D (Independence type) | -55~+125 |
| | 4D | | | 4 | | |
| RAC16 | 4D | 50 | 100 | 4 | | |
| | 8D | 25 | 100 | 8 | | |

Note. Rated current of chip jumper: 1(A)

Note. Resistance value of chip jumper: 50mΩ max.

3.2 Climatic category

| | | |
|-----------|--|---------|
| 55/125/56 | Lower category temperature | -55 °C |
| | Upper category temperature | +125 °C |
| | Duration of the damp heat, steady state test | 56days |

3.3 Stability class

5%

Limits for change of resistance:

- for long-term tests $\pm(5\%+0.1\Omega)$ Chip jumper: 50 m Ω max.
- for short-term tests $\pm(1\%+0.05\Omega)$ Chip jumper: 50 m Ω max.

3.4 Derating

The derated values of dissipation (or current rating in case of chip jumper) at temperature in excess of 70 °C shall be as indicated by the following curve.

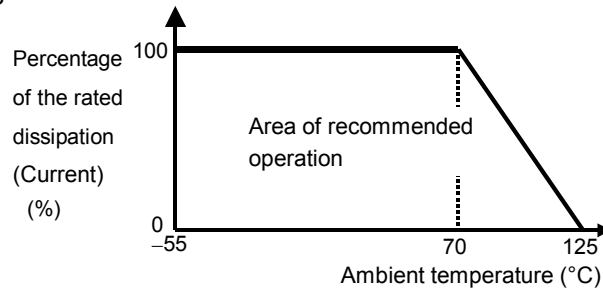

Figure-1 Derating curve

3.5 Rated voltage

d. c. or a. c. r. m. s. voltage calculated from the square root of the product of the rated resistance and the rated dissipation.

$$E = \sqrt{P \cdot R}$$

- E : Rated voltage (V)
- P : Rated dissipation (W)
- R : Rated resistance (Ω)

Limiting element voltage can only be applied to resistors when the resistance value is equal to or higher than the critical resistance value.

At high value of resistance, the rated voltage may not be applicable.

4. Packaging form

The standard packaging form shall be in accordance with Table-2.

Table-2

| Symbol | Packaging form | | Standard packaging quantity / units | Application |
|--------|----------------------|------------------------|-------------------------------------|----------------------------|
| B | Bulk (loose package) | | 1,000 pcs. | RAC10 2D, 4D, RAC16 4D, 8D |
| TH | Paper taping | 8mm width, 2mm pitches | 10,000 pcs. | RAC10 2D, 4D |
| TP | Paper taping | 8mm width, 4mm pitches | 5,000 pcs. | RAC16 4D, 8D |

5. Dimensions

The resistor shall be of the design and physical dimensions in accordance with below.

5.1 RAC10 2D

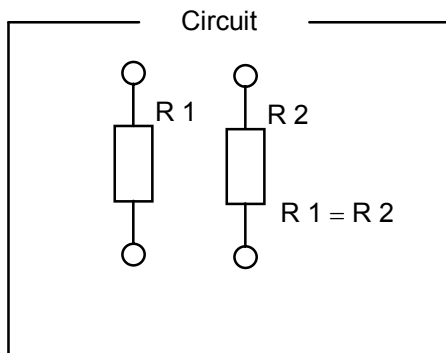
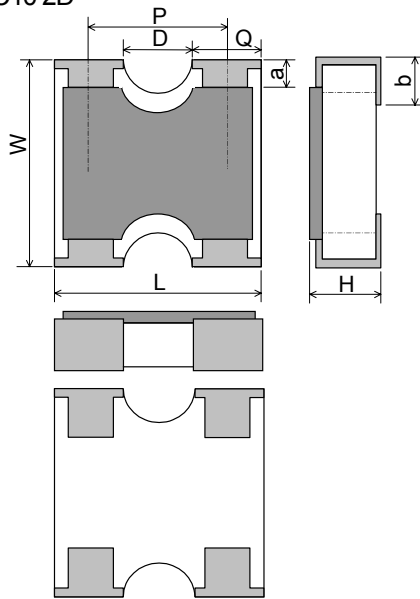

Figure-2

5.2 RAC10 4D

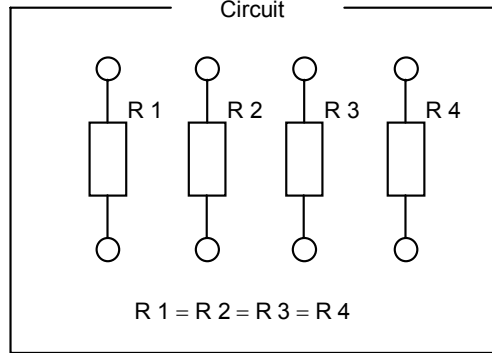
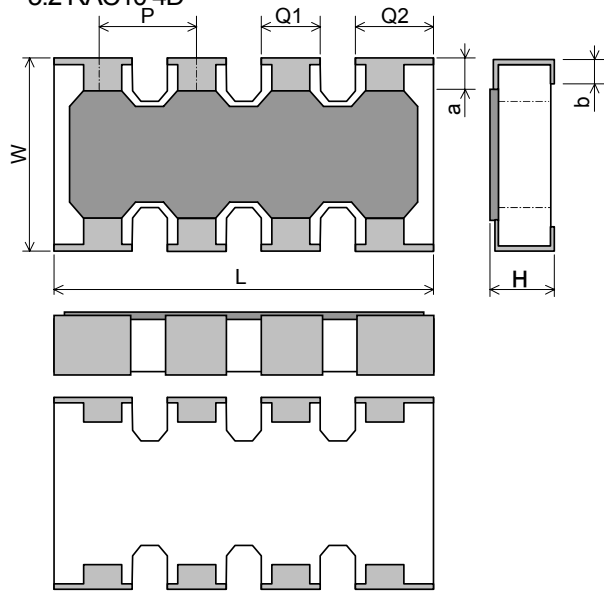

Figure-3

Table-3

Unit: mm

| Style | Terminations style | Country of origin | L | W | H | Q or Q ₁ | *Q ₂ |
|----------|--------------------|-------------------|----------|----------|-----------|---------------------|-----------------|
| RAC10 2D | C | Malaysia, | 1.0±0.05 | 1.0±0.05 | 0.35±0.05 | 0.33±0.10 | — |
| | | China | 1.0±0.1 | 1.0±0.1 | 0.35±0.10 | 0.34±0.05 | — |
| RAC10 4D | C | Malaysia, | 2.0±0.1 | 1.0±0.1 | 0.35±0.05 | 0.35±0.10 | 0.45±0.10 |
| | | China | 2.0±0.1 | 1.0±0.1 | 0.45±0.10 | 0.3±0.05 | 0.4±0.1 |

| Style | Country of origin | D | a | b | *P |
|----------|-------------------|-----------|-----------|--|------|
| RAC10 2D | Malaysia, | 0.34±0.10 | 0.15±0.10 | 0.25 ^{+0.05} _{-0.10} | 0.65 |
| | China | | 0.2±0.15 | 0.25±0.17 | 0.65 |
| RAC10 4D | Malaysia, | | 0.15±0.10 | 0.25±0.10 | 0.5 |
| | China | | 0.2±0.1 | 0.25±0.10 | 0.5 |

*Reference

5.3 RAC16 4D

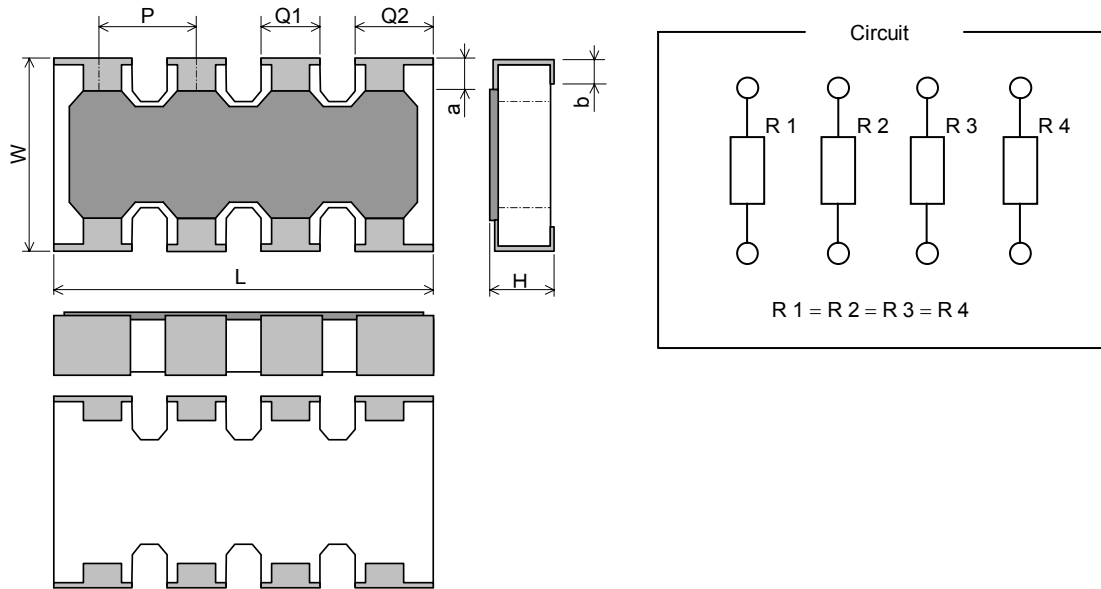

Figure-4
 Table-4

Unit: mm

| Style | Terminations style | Country of origin | L | W | H | Q ₁ | a |
|----------|--------------------|-------------------|---------|---------|---------|----------------|---------|
| RAC16 4D | C | Malaysia, | 3.2±0.1 | 1.6±0.1 | 0.5±0.1 | 0.4±0.15 | 0.3±0.2 |
| | | China | 3.2±0.1 | 1.6±0.1 | 0.5±0.1 | 0.4±0.1 | 0.3±0.1 |

| Style | Country of origin | b | *Q ₂ | *P |
|----------|-------------------|-----------|-----------------|-----|
| RAC16 4D | Malaysia, | 0.25±0.15 | 0.6±0.15 | 0.8 |
| | China | 0.3±0.2 | 0.6±0.1 | 0.8 |

*Reference

5.4 RAC16 8D

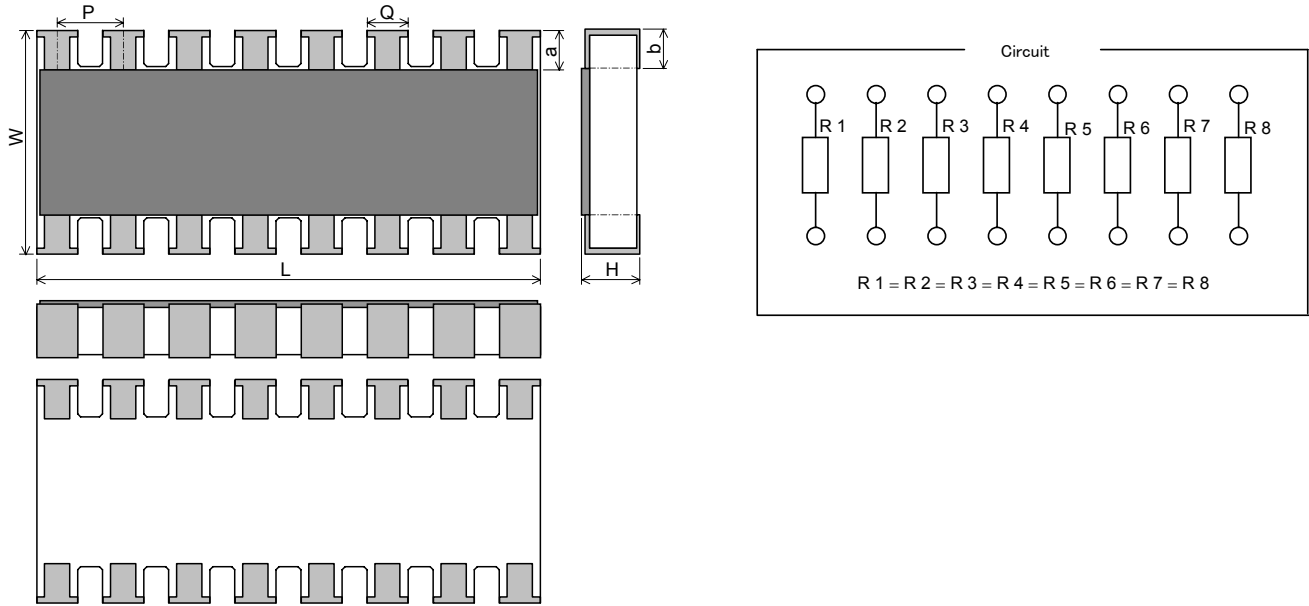

Figure-5
 Table-5

Unit: mm

| Style | Terminations style | Country of origin | L | W | H | Q | a |
|---------|--------------------|-------------------|---------|---------|-----------|---------|---------|
| RAC168D | C | China | 3.8±0.1 | 1.6±0.1 | 0.45±0.10 | 0.3±0.1 | 0.3±0.1 |

*Reference

| Style | Country of origin | b | *P |
|---------|-------------------|---------|---------|
| RAC168D | China | 0.3±0.1 | 0.5±0.1 |

5.2 Net weight (Reference)

| Style | Terminations style | Net weight(mg) |
|----------|--------------------|----------------|
| RAC10 2D | C | 1.1 |
| RAC10 4D | C | 2.1 |
| RAC16 4D | C | 7 |
| RAC16 8D | C | 8.3 |

6. Marking

The Rated resistance of RAC10 2D should not be marked.

6.1 For the resistors

The rated resistance shall be marked in 3 digits (E24) and marked on over coat side.

| Marking example | | Contents | Application |
|-----------------|-------|--|-------------|
| Malaysia | China | | |
| 123 | 123 | $12 \times 10^3 [\Omega] \rightarrow 12 [k\Omega]$ | RAC104D |
| D123 | 123 | $12 \times 10^3 [\Omega] \rightarrow 12 [k\Omega]$ | RAC164D |
| --- | 123 | $12 \times 10^3 [\Omega] \rightarrow 12 [k\Omega]$ | RAC168D |

6.2 For the Jumper Chip

| Marking example | | Contents | Application |
|-----------------|-------|----------|-------------|
| Malaysia | China | | |
| □ | 000 | JP | RAC104D |
| DO | 000 | JP | RAC164D |
| --- | 000 | JP | RAC168D |

7. Performance

7.1 The standard condition for tests shall be in accordance with Sub-clause 4. 2, JIS C 5201-1: 1998.

7.2 The performance shall be satisfied in Table-6.

Table-6(1)

| No. | Test items | Condition of test (JIS C 5201-1) | Performance requirements |
|-----|-------------------------|---|---|
| 1 | Visual examination | Sub-clause 4. 4. 1 Checked by visual examination. | As in 4. 4. 1 The marking shall be legible, as checked by visual examination. |
| 2 | Dimension Resistance | Sub-clause 4. 4. 2 Sub-clause 4. 5 | As specified in sub clause 5.1 of this specification. As in 4. 5. 2 The resistance value shall correspond with the rated resistance taking into account the specified tolerance. Chip jumper: 50 mΩ max. |
| 3 | Voltage proof | Sub-clause 4. 7 Method: 4. 6. 1. 4(See Figure-8) Test voltage: Alternating voltage with a peak value of 1.42 times the insulation voltage. Duration: 60 s ± 5 s Insulation resistance Test voltage: Insulation voltage Duration: 1 min. | No breakdown or flash over $R \geq 1 G \Omega$ |
| 4 | Solderability | Sub-clause 4. 17 Without ageing Flux: The resistors shall be immersed in a non-activated soldering flux for 2s. Bath temperature: 235 °C ± 5 °C Immersion time: 2 s ± 0.5 s | As in 4. 17. 4. 5 The terminations shall be covered with a smooth and bright solder coating. |

Table-6(2)

| No | Test items | Condition of test (JIS C 5201 - 1) | Performance requirements |
|----|---|--|---|
| 5 | Mounting Overload (in the mounted state) Solvent resistance of the marking | Sub-clause 4. 31 Substrate material: Epoxide woven glass Test substrate: Figure-6 Sub-clause 4. 13 The applied voltage shall be 2.5 times the rated voltage or twice the limiting element voltage, whichever is the less severe. Duration: 2 s Visual examination Resistance Sub-clause 4. 30 Solvent: 2-propanol Solvent temperature: 23°C±5°C Method 1 Rubbing material: cotton wool Without recovery | No visible damage $\Delta R \leq \pm (1\%+0.05\Omega)$ Chip jumper: 50 mΩ max. Legible marking |
| 6 | Mounting Bound strength of the end face plating Final measurements | Sub-clause 4. 31 Substrate material: Epoxide woven glass Test substrate: Figure-7 Sub-clause 4. 33 Bent value: 3 mm Resistance Sub-clause 4. 33. 6 Visual examination | $\Delta R \leq \pm (1\%+0.05\Omega)$ Chip jumper: 50 mΩ max. No visible damage |
| 7 | Resistance to soldering heat Component resistance solvent | Sub-clause 4. 18 Solder temperature: 260°C±5°C Immersion time: 10s±0.5s Visual examination Resistance Sub-clause 4.29 Solvent: 2-propanol Solvent temperature: 23°C±5°C Method 2 Recovery: 48 h Visual examination Resistance | As in 4. 18. 3. 4 No sign of damage such as cracks. $\Delta R \leq \pm (1\%+0.05\Omega)$ Chip jumper: 50 mΩ max. No visible damage $\Delta R \leq \pm (1\%+0.05\Omega)$ Chip jumper: 50 mΩ max. |

Table-6(3)

| No | Test items | Condition of test (JIS C 5201 - 1) | Performance requirements |
|----|--|--|--|
| 8 | Mounting Adhesion Rapid change temperature | Sub-clause 4. 31 Substrate material: Epoxide woven glass Test substrate: Figure-6 Sub-clause 4. 32 Force: 5 N Duration: 10s±1s Visual examination Sub-clause 4.19 Lower category temperature : -55 °C Upper category temperature : +125 °C Duration of exposure at each temperature: 30 min. Number of cycles: 5 cycles. Visual examination Resistance | No visible damage No visible damage $\Delta R \leq \pm(1\%+0.05\Omega)$ Chip jumper: 50 mΩ max. |
| 9 | Climatic sequence -Dry heat -Damp heat, cycle (12+12hour cycle) First cycle -Cold -Damp heat, cycle (12+12hourcycle) Remaining cycle -D.C. load | Sub-clause 4. 23 Sub-clause 4. 23. 2 Test temperature: +125 °C Duration: 16 h Sub-clause 4. 23. 3 Test method : 2 Test temperature: 55 °C [Severity(2)] Sub-clause 4. 23. 4 Test temperature-55 °C Duration: 2h Sub-clause 4. 23. 6 Test method: 2 Test temperature: 55 °C [Severity (2)] Number of cycles: 5 cycles Sub-clause 4. 23. 7 The applied voltage shall be the rated voltage or the limiting element voltage whichever is the smaller. Duration: 1 min. Visual examination Resistance | No visible damage $\Delta R \leq \pm (5\%+0.1\Omega)$ Chip jumper: 50 mΩ max. |

Table-6(4)

| No | Test items | Condition of test (JIS C 5201 - 1) | Performance requirements |
|----|--|--|--|
| 10 | Mounting Endurance at 70 °C | Sub-clause 4. 31 Substrate material: Epoxide woven glass Test substrate: Figure-6 Sub-clause 4. 25. 1 Ambient temperature: 70°C±2°C Duration: 1000 h The voltage shall be applied in cycles of 1. 5 h on and 0. 5 h off. The applied voltage shall be the rated voltage or the limiting element voltage whichever is the smaller. Examination at 48 h , 500 h and 1000 h: Visual examination Resistance | No visible damage Δ R ≤ ± (5%+0.1Ω) Chip jumper: 50 mΩ max. |
| 11 | Mounting Variation of resistance with temperature | Sub-clause 4. 31 Substrate material: Epoxide woven glass Test substrate: Figure-6 Sub-clause 4. 8 -55 °C / +20 °C +20 °C / +125°C | As in Table-1 |
| 12 | Mounting Damp heat, steady state | Sub-clause 4. 31 Substrate material: Epoxide woven glass Test substrate: Figure-6 Sub-clause 4. 24 Ambient temperature: 40°C±2°C Relative humidity : 93 $\frac{+2}{-3}$ % a) 1st group: without voltage applied. b) 2nd group: The d. c. voltage shall be applied continuously. The voltage shall be accordance with Sub-clause 4. 24. 2 .1 b). without polarizing voltage [4. 24. 2. 1, c]) Visual examination Resistance | No visible damage Legible marking Δ R ≤ ± (5%+0.1Ω) Chip jumper: 50 mΩ max. |

Table-6(5)

| No | Test items | Condition of test (JIS C 5201 - 1) | Performance requirements |
|----|--|--|---|
| 13 | Dimensions (detail) Mounting Endurance at upper category temperature | Sub-clause 4. 4. 3 Sub-clause 4. 31 Substrate material: Epoxide woven glass Test substrate: Figure-6 Sub-clause 4. 25. 3 Ambient temperature: 125°C±2°C Duration: 1000 h Examination at 48 h, 500 h and 1000 h: Visual examination Resistance | As in Sub-clause 5.1 of this specification No visible damage $\Delta R \leq \pm (5\%+0.1\Omega)$ Chip jumper: 50 mΩ max. |

8. Test substrate

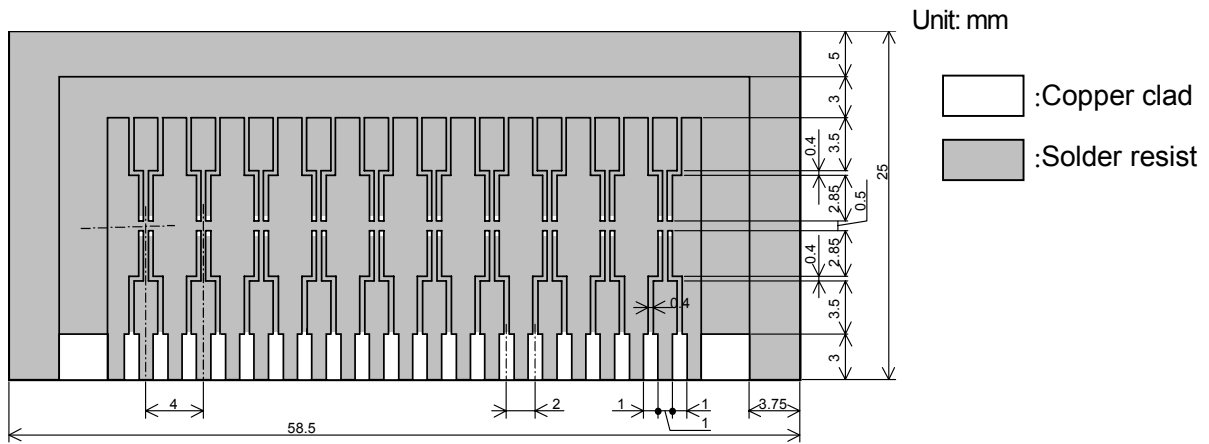

RAC10 2D TEST SUBSTRATE

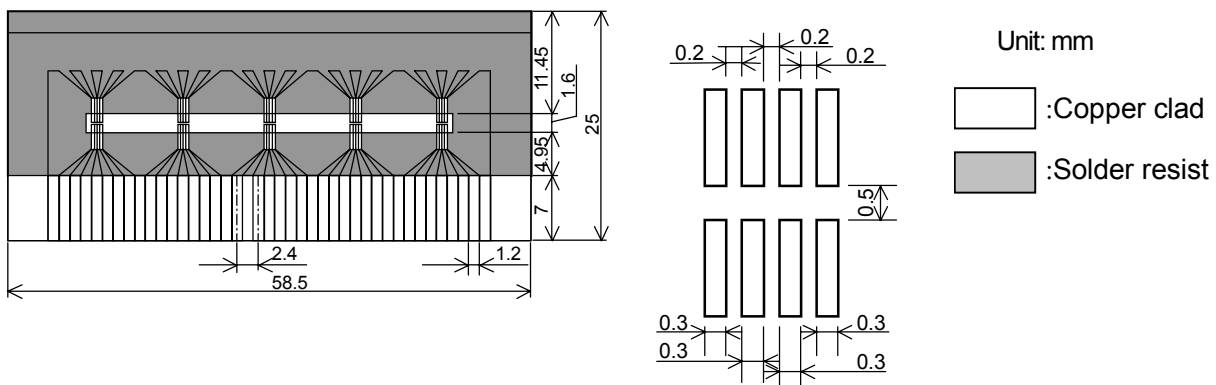

RAC10 4D TEST SUBSTRATE

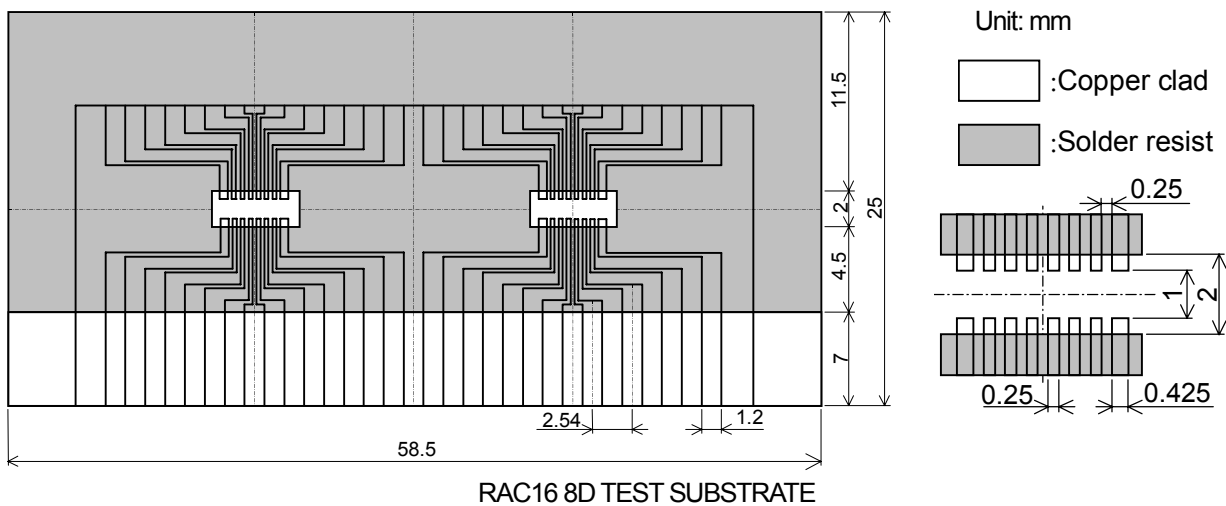
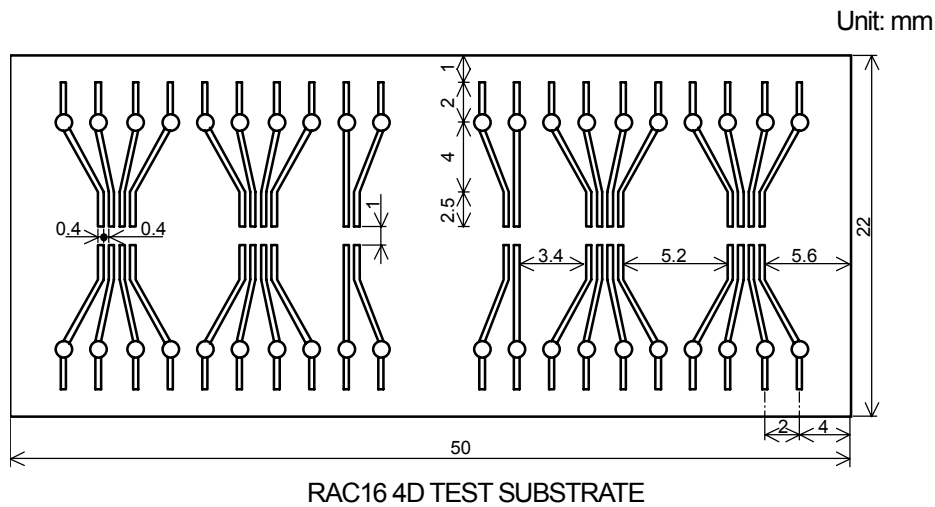

- Remark 1). Material: Epoxide woven glass
 Thickness: 1.6mm Thickness of copper clad: 0.035mm
- 2). In the case of connection by connector, the connecting terminals are gold plated.
 However, the plating is not necessary when the connection is made by soldering.

Figure-6

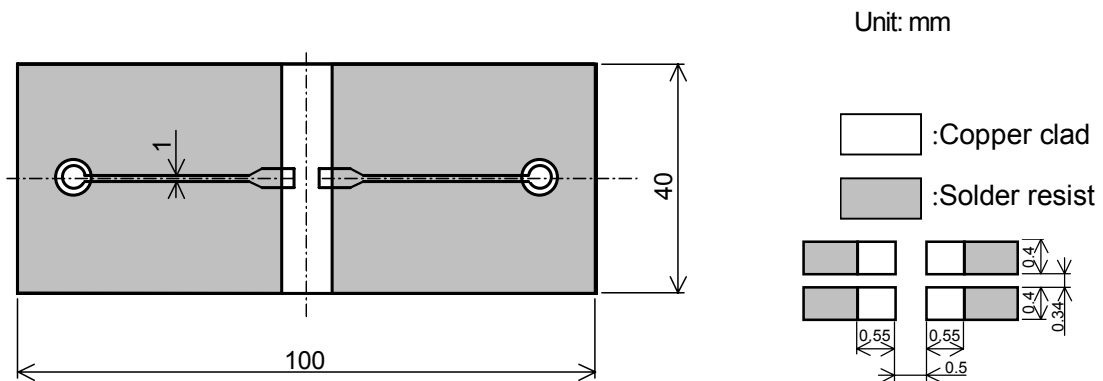

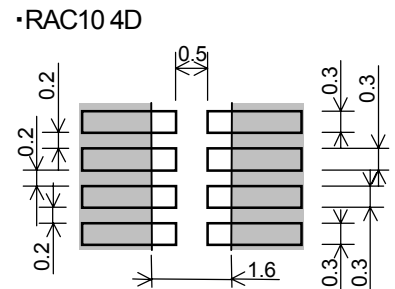
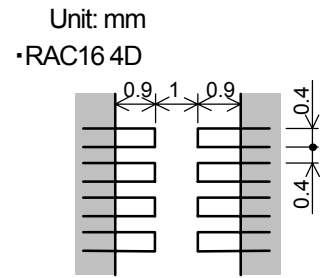
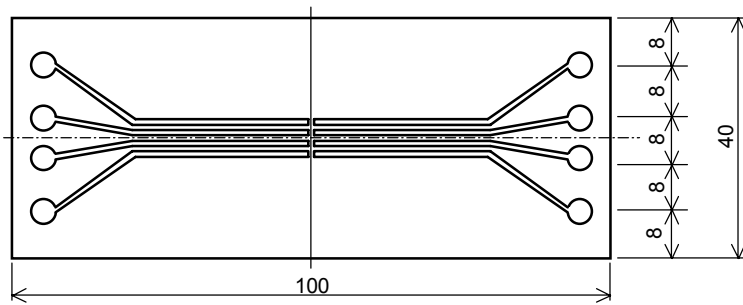

RAC10 4D, 16 4D BOUND STRENGTH OF THE END FACE PLATING TEST SUBSTRATE

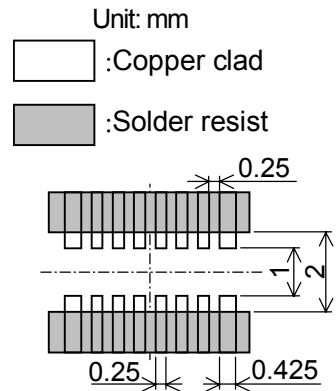
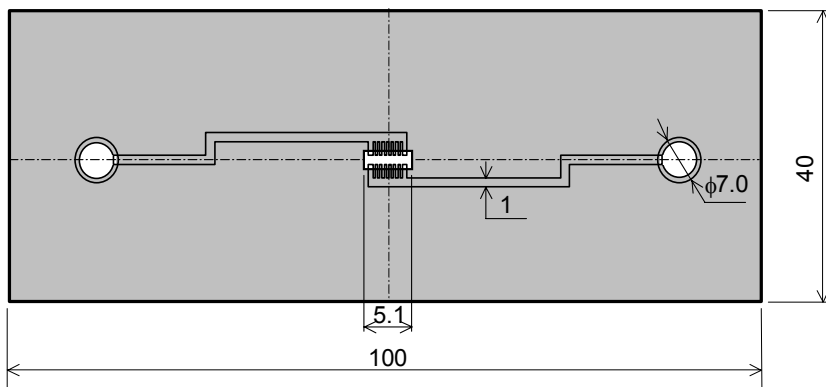

RAC16 8D TERMINAL STRENGTH TEST SUBSTRATE

Remark 1). Material: Epoxide woven glass
 Thickness: 1.6mm Thickness of copper clad: 0.035mm

Figure-7

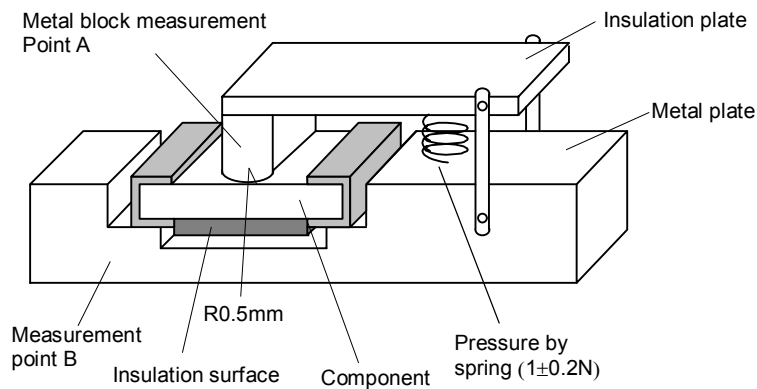

Figure-8

9. Taping

9.1 Applicable documents JIS C 0806-3: 1999, EIAJ ET-7200B: 2003

9.2 Taping dimensions

9.2.1 RAC10 2D, RAC10 4D (Paper taping, 8mm width, 2mm pitches)

Taping dimensions shall be in accordance with Figure-8 and Table-7.

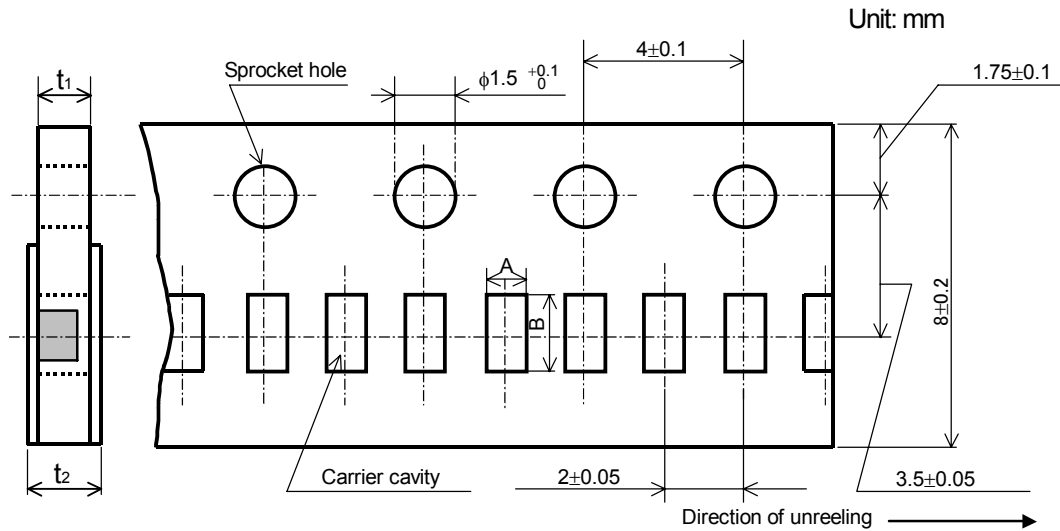

Figure-9

Table-7

Unit: mm

| Style | A | B | t ₁ | t ₂ |
|----------|--|--|---------------------------------------|----------------|
| RAC10 2D | 1.15 ^{+0.05} _{-0.10} | 1.15 ^{+0.05} _{-0.10} | 0.4 ^{+0.05} _{-0.10} | 0.5max. |
| RAC10 4D | 1.2±0.1 | 2.2±0.1 | 0.4±0.1 | |

9.2.2 RAC16 4D, RAC16 8D (Paper taping, 8mm width, 4mm pitches)

Taping dimensions shall be in accordance with Figure-10 and Table-8.

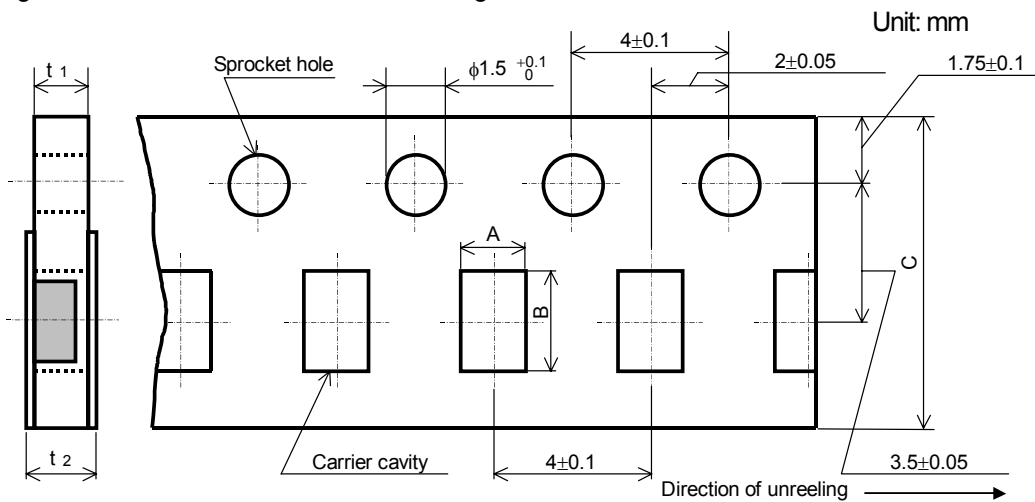

Figure-10

Table-8

Unit: mm

| Style | A | B | C | t ₁ | t ₂ |
|----------|----------|----------|---------|----------------|----------------|
| RAC16 4D | 1.9±0.15 | 3.6±0.2 | 8.0±0.2 | 0.6±0.1 | 0.8max. |
| RAC16 8D | 1.9±0.15 | 4.1±0.15 | 8.0±0.3 | | |

- 1). The cover tapes shall not cover the sprocket holes.
- 2). Tapes in adjacent layers shall not stick together in the packing.
- 3). Components shall not stick to the carrier tape or to the cover tape.
- 4). Pitch tolerance over any 10 pitches $\pm 0.2\text{mm}$.
- 5). The peel strength of the top cover tape shall be within 0.1N to 0.5N on the test method as shown in the following Figure-11.
- 6). When the tape is bent with the minimum radius for 25 mm, the tape shall not be damaged and the components shall maintain their position and orientation in the tape.
- 7). In no case shall there be two or more consecutive components missing.
 The maximum number of missing components shall be one or 0.1%, whichever is greater.
- 8). The resistors shall be faced to upward at the over coating side in the carrier cavity.
- 9). The direction of resistor shall be taped as Figure-12.

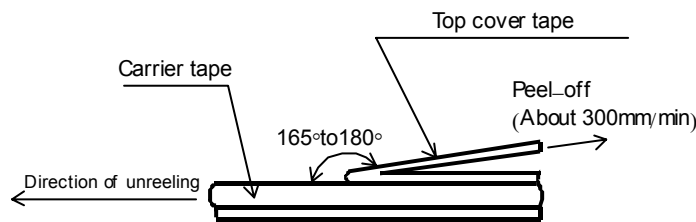

Figure-11

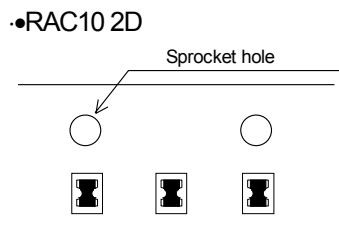

Figure-12

9.3 Reel dimension

Reel dimensions shall be in accordance with the following Figure-13 and Table-9.
 Plastic reel (Based on EIAJ ET-7200B)

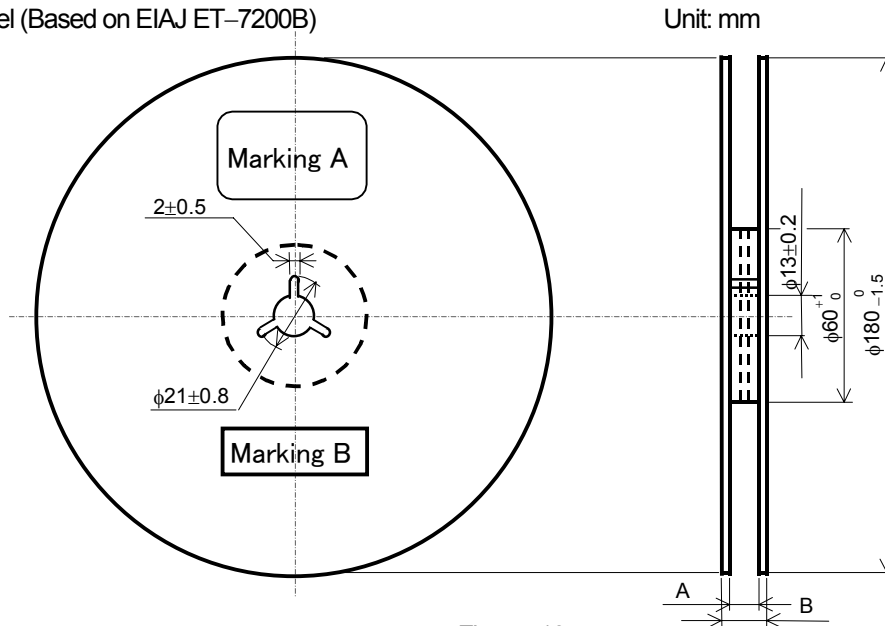

Figure-13

Table-9

Unit: mm

| Style | A | B | Note |
|----------|--------------------------------|----------|-------------------|
| RAC10,16 | 9 ^{+1.0} ₀ | 11.4±1.0 | Injection molding |
| | | 13±1.0 | Vacuum forming |

Note: Marking label shall be marked on a place of Marking A or two place of marking A and B.

9.4 Leader and trailer tape.

(Example)

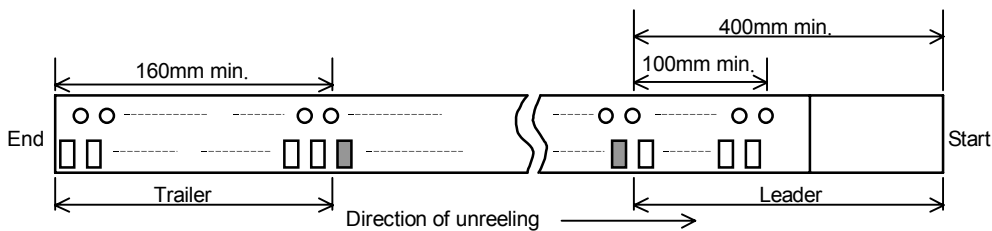

Figure-14

10. Marking on package

The label of a minimum package shall be legibly marked with follows.

10.1 Marking A

- (1) Classification (Style, Rated resistance, Tolerance on rated resistance, Terminal style, Packaging form)
- (2) Quantity (3) Lot number (4) Manufacturer's name or trade mark (5) Others

10.2 Marking B (KAMAYA Control label)

Mouser Electronics

Authorized Distributor

Click to View Pricing, Inventory, Delivery & Lifecycle Information:

[RAC164D473JCTP](#) [RAC104D221JCTH](#) [RAC164D220JCTP](#) [RAC104D102JCTH](#) [RAC102D471JCTH](#)
[RAC164D302JCTP](#) [RAC164D111FCTP](#) [RAC104D330JCTH](#) [RAC164D512JCTP](#) [RAC164D333JCTP](#)
[RAC104D472JCTH](#) [RAC164D681JCTP](#) [RAC164D103JCTP](#) [RAC164D680JCTP](#) [RAC164D202JCTP](#)
[RAC164D201JCTP](#) [RAC104D474JCTH](#) [RAC164D101JCTP](#) [RAC104D332JCTH](#) [RAC104D103JCTH](#)
[RAC164D153JCTP](#) [RAC164DJPCTP](#) [RAC104D390JCTH](#) [RAC164D101FCTP](#) [RAC164D132JCTP](#)
[RAC164D102JCTP](#) [RAC164D330JCTP](#) [RAC164D161JCTP](#) [RAC102D220JCTH](#) [RAC164D513JCTP](#)
[RAC164D360JCTP](#) [RAC164D104JCTP](#) [RAC164D100JCTP](#) [RAC102D104JCTH](#) [RAC104D822JCTH](#)
[RAC104DJPCTH](#) [RAC104D223JCTH](#) [RAC164D392JCTP](#) [RAC104D151JCTH](#) [RAC102D361JCTH](#)
[RAC104D201JCTH](#) [RAC164D332JCTP](#) [RAC104D150JCTH](#) [RAC164D152JCTP](#) [RAC164D151JCTP](#)
[RAC104D152JCTH](#) [RAC104D104JCTH](#) [RAC104D473JCTH](#) [RAC164D472FCTP](#) [RAC164D303JCTP](#)
[RAC104D304JCTH](#) [RAC164D154JCTP](#) [RAC104D220JCTH](#) [RAC104D100JCTH](#) [RAC104D101JCTH](#)
[RAC164D472JCTP](#) [RAC104D470JCTH](#) [RAC102D330JCTH](#) [RAC164D821JCTP](#) [RAC164D393JCTP](#)
[RAC164D331JCTP](#) [RAC164D131JCTP](#)

Компания «Life Electronics» занимается поставками электронных компонентов импортного и отечественного производства от производителей и со складов крупных дистрибьюторов Европы, Америки и Азии.

С конца 2013 года компания активно расширяет линейку поставок компонентов по направлению коаксиальный кабель, кварцевые генераторы и конденсаторы (керамические, пленочные, электролитические), за счёт заключения дистрибьюторских договоров

Мы предлагаем:

- Конкурентоспособные цены и скидки постоянным клиентам.
- Специальные условия для постоянных клиентов.
- Подбор аналогов.
- Поставку компонентов в любых объемах, удовлетворяющих вашим потребностям.
- Приемлемые сроки поставки, возможна ускоренная поставка.
- Доставку товара в любую точку России и стран СНГ.
- Комплексную поставку.
- Работу по проектам и поставку образцов.
- Формирование склада под заказчика.
- Сертификаты соответствия на поставляемую продукцию (по желанию клиента).
- Тестирование поставляемой продукции.
- Поставку компонентов, требующих военную и космическую приемку.
- Входной контроль качества.
- Наличие сертификата ISO.

В составе нашей компании организован Конструкторский отдел, призванный помогать разработчикам, и инженерам.

Конструкторский отдел помогает осуществить:

- Регистрацию проекта у производителя компонентов.
- Техническую поддержку проекта.
- Защиту от снятия компонента с производства.
- Оценку стоимости проекта по компонентам.
- Изготовление тестовой платы монтаж и пусконаладочные работы.



Тел: +7 (812) 336 43 04 (многоканальный)

Email: org@lifeelectronics.ru