

Description

One and two pole thermal-magnetic circuit breaker in compact design with slide actuator, trip-free mechanism, various trip characteristics and optional auxiliary contacts.

Meets the requirements of the circuit breaker standard EN 60934 (IEC 60934): S-type, TM.

Typical applications

Protection of AC and DC control circuits in industrial automation applications and buildings, e.g. in the chemical industry, power plants, steel industry and machine construction (machine tools, packing machines etc.)

Ordering information

Type no.	2216 thermal-magnetic circuit breaker
Mounting method	S1 plug-in mounting
Number of poles	1 1-pole 2 2-pole
Additional function / accessories	0 without
Main terminals	P1 blade terminals A6.3 x 0.8 with polarising tooth (standard)
Characteristic curve	F1 therm. 1.01-1.4 x I _N ; magn. 2-4 x I _N (only for DC) F2 therm. 1.01-1.4 x I _N ; magn. 3-6 x I _N AC / 4-8 I _N DC M1 therm. 1.01-1.4 x I _N ; magn. 6-12 x I _N AC / 8-15 I _N DC
Auxiliary contacts	S0 without auxiliary contact S1 with auxiliary contact
Auxiliary contact function	0 without 1 change-over
Auxiliary contact terminals	0 without 1 blade terminals A6.3 x 0.8 with polarising tooth (standard)
Voltage rating	A ≤ AC 277 V, ≤ DC 80 V
Current ratings	0.5...16 A
2216 - S1 1 0 - P1 F1 - S1 1 1 - A-16A Ordering example	

Standard current ratings and typical internal resistance values

Current rating (A)	Internal resistance (Ω)	Current rating (A)	Internal resistance (Ω)
0.5	5.0	6	0.05
1	1.1	8	≤ 0.02
2	0.3	10	≤ 0.02
3	0.14	12	≤ 0.02
4	0.09	15	≤ 0.02
5	0.06	16	≤ 0.02

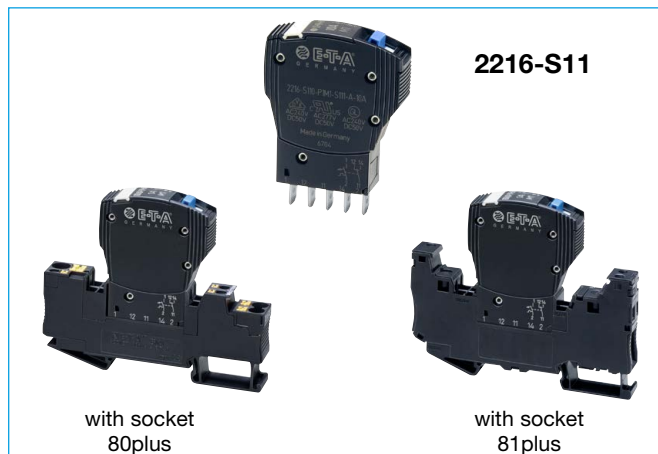

Technical data

Voltage rating	AC 240 V (50/60 Hz); DC 50 V (1-pole) DC 80 V (2-pole)
Current rating range	0.5...16 A
Auxiliary circuit	AC 240 V, 0.5 A (VDE) AC 277 V, 0.5 A (UL) DC 50 V, 1 A (VDE/UL)
Typical life	6,000 operations at 1 x I _N 3,000 operations at 1 x I _N DC 80 V, 2-pole
Ambient temperature	-30...60 °C
Insulation co-ordination (IEC 60664)	2.5 kV/2 re-inforced insulation in operating area
Dielectric strength	operating area main/aux. circuit test voltage AC 3,000 V test voltage AC 1,500 V
Open aux. circuit	AC 1,000 V
Insulation resistance	> 100 MΩ (DC 500 V)
Interrupting capacity I _{cn}	AC 240 V 1-pole 300 A DC 32 V 1-pole 1500 A DC 50 V 1-pole 600 A AC 240 V 2-pole 400 A DC 32 V 2-pole 1500 A DC 80 V 2-pole 600 A
Interrupting capacity (UL 1077)	AC 277 V 1,000 A DC 50 V 1-pole 1,000 A DC 80 V 2-pole 1,000 A
Degree of protection (IEC 60529)	operating area IP30 terminal area IP00
Vibration	curve F1: 5 g (57-500 Hz), ± 0.38 mm (10-57 Hz); curves F2, M1: 8 g (57-500 Hz) ± 0.61 mm (10-57 Hz) test to IEC 60068-2-6, test Fc, 10 frequency cycles per axis
Shock	curve F1: 15 g (11 ms) for shock direction 1-6 curves F2, M1: 30 g (11 ms) for shock direction 1-6 test to IEC 60068-2-27, test Ea
Corrosion	96 hrs in 5 % salt mist, test to IEC 60068-2-11, test Ka
Humidity	240 hrs in 95 % RH, test to IEC 60068-2-78, test Cab
Mass	approx. 25 g (per pole with aux. contact)

Approvals

Authority	Standard	Voltage ratings	Current ratings
CSA	C22.2 No. 235	AC 277 V DC 50 V DC 80 V	0.1...16 A (1-, 2-pole) 0.1...16 A (1-pole) 0.1...16 A (2-pole)
VDE	IEC / EN 60934	AC 240 V DC 50 V DC 80 V	0.1...16 A (1-, 2-pole) 0.1...16 A (1-pole) 0.1...16 A (2-pole)
UL	UL 1077 C22.2 No 235	AC 277 V DC 50 V DC 80 V	0.1...16 A (1-, 2-pole) 0.1...16 A (1-pole) 0.1...16 A (2-pole)
GL	IEC / EN 60934	AC 240 V DC 50 V DC 80 V	0.1...16 A (1-, 2-pole) 0.1...16 A (1-pole) 0.1...16 A (2-pole)
UL *)	UL 60947-4-1A C22.2 No 60947-4-1	AC 277 V DC 50 V DC 80 V	0.1...10 A (1-, 2-pole) 0.1...16 A (1-pole) 0.1...10 A (2-pole)

*) cULus (listed) using with socket 80PLUS or socket 81PLUS

Dimensions 2216-S11 with socket 80plus

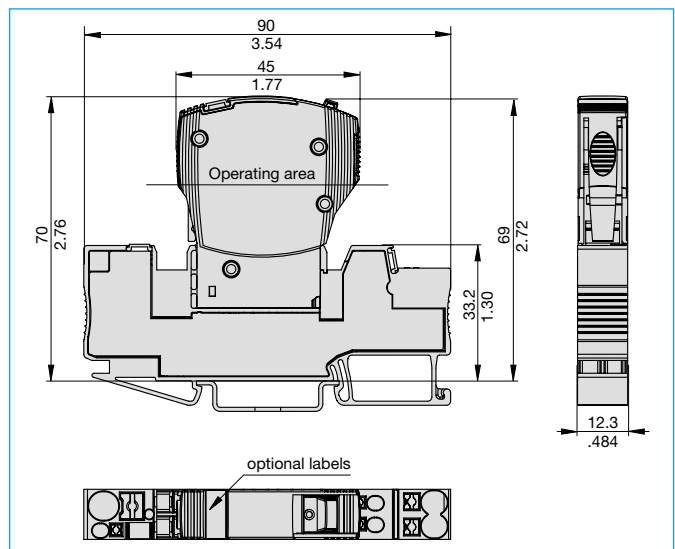

Schematic diagram

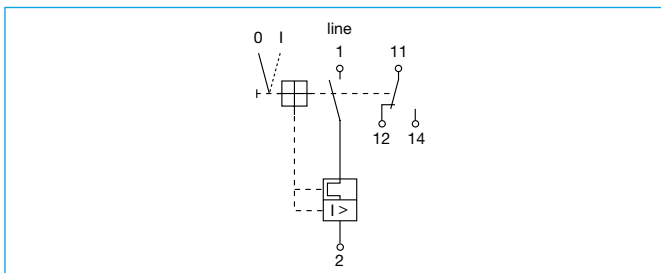

Dimensions 2216-S11 with socket 81plus

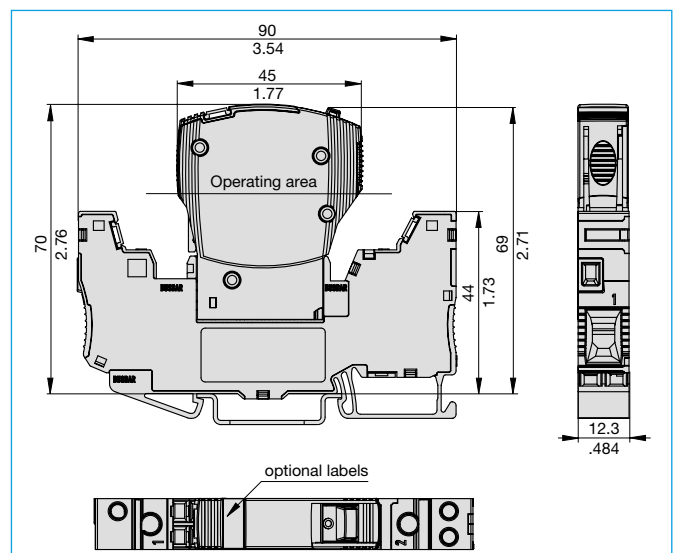

Dimensions 2216-S1

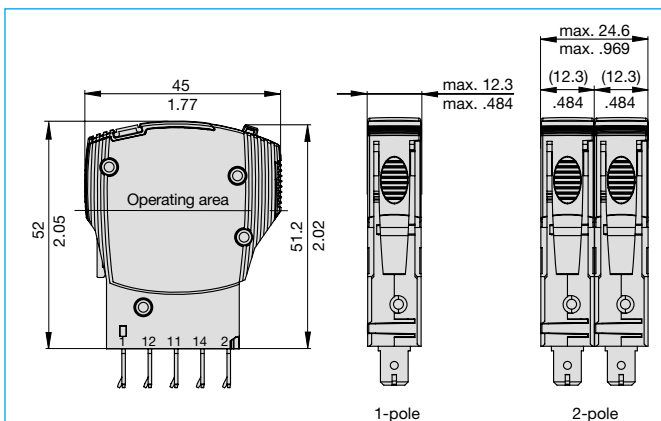

Shock directions

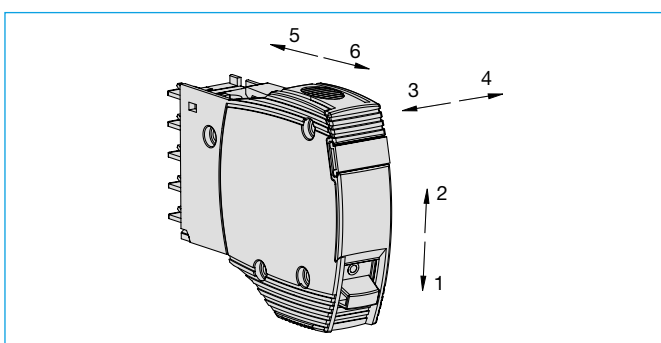

Envelope size to DIN 43880

The envelope size of type 2216-S with socket 80plus or 81plus complies with the requirements of DIN 43880 (built-in equipment for electrical installation).

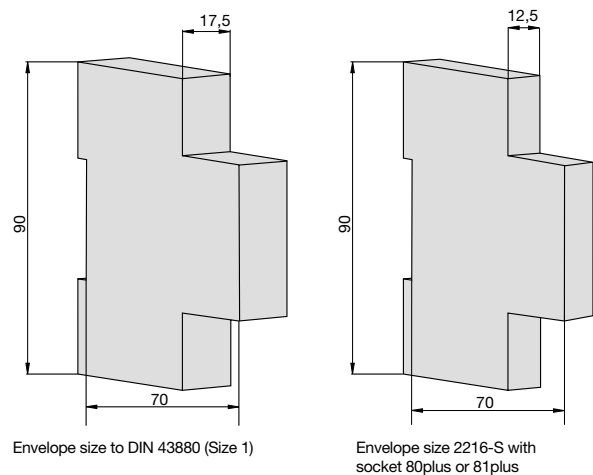

Time/current characteristics

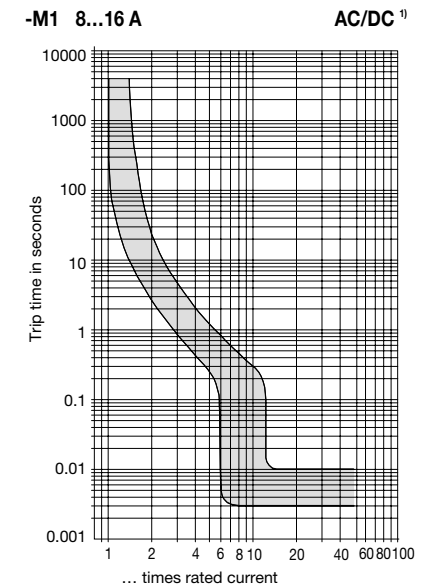
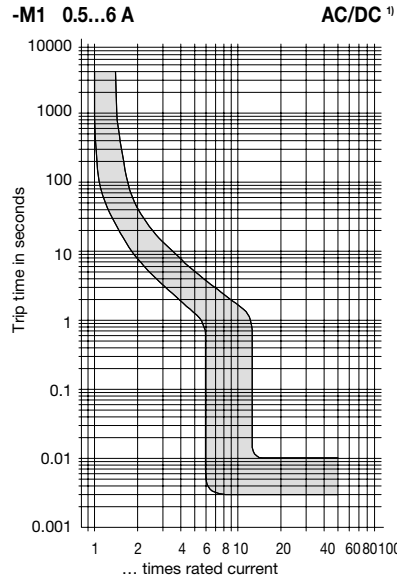
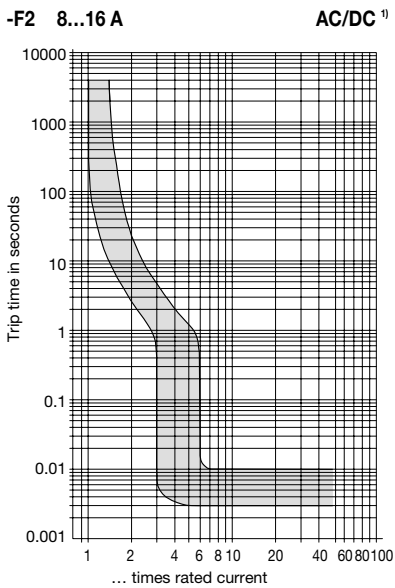
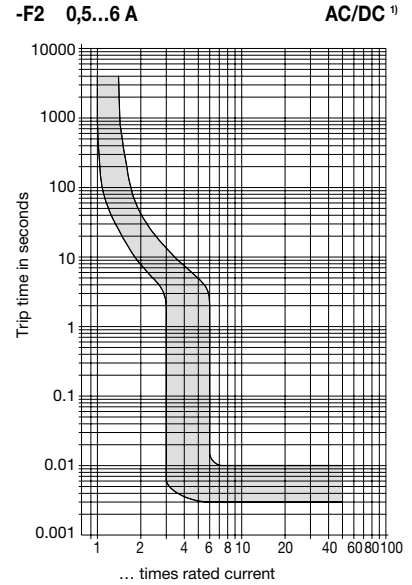
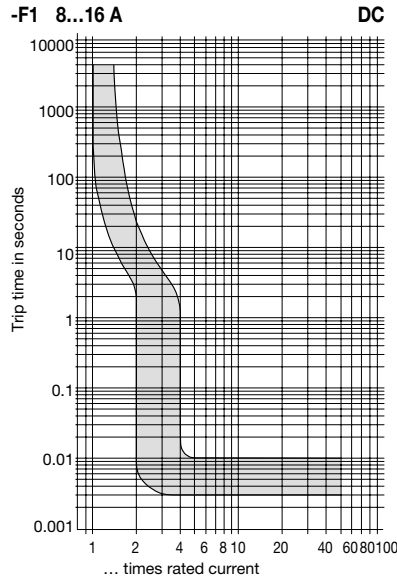
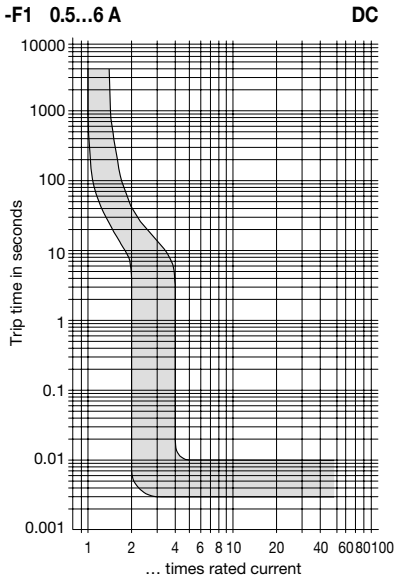

¹⁾ Magnetic tripping currents are or the curves M1 and F2 are increased by 30 % on DC supplies.

When mounted side-by-side, the breakers can only carry up to 80 % of their rated or a higher rating should be selected (please also see Technical Information).

The time current characteristic curve depends on the ambient temperature. In order to eliminate nuisance tripping, please multiply the circuit breaker current ratings by the derating factor shown below (please also see Technical Information).

Ambient temperature °C	-30	-20	-10	0	10	23	30	40	50	60
Derating factor	0.76	0.79	0.83	0.88	0.93	1	1.04	1.12	1.22	1.35

Caution: High inrush peaks of < 0.003 sec. may trip the breaker.

This is a metric design and millimeter dimensions take precedence ($\frac{\text{mm}}{\text{inch}}$)

All dimensions without tolerances are for reference only. In the interest of improved design, performance and cost effectiveness the right to make changes in these specifications without notice is reserved. Product markings may not be exactly as the ordering codes. Errors and omissions excepted.

Description

Single pole, with PT connection technology, to accommodate 1- or 2-pole circuit breakers type 2216-S

Part number: 80PLUS-PT01

- Push-in design: push the stripped wire (cross section $\geq 0.25 \text{ mm}^2$, rigid or with wire end ferrule) into the round hole of the terminal without using a tool
- For smaller cable cross sections or flexible wires without wire end ferrule you have to push in the orange push button to open the spring.
- For release push in the orange push button with a screw driver.

Dimensions

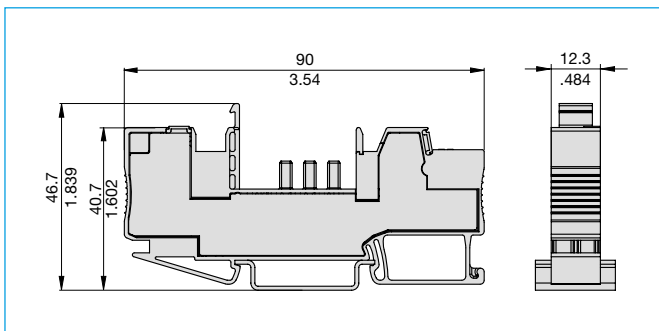

Line connection

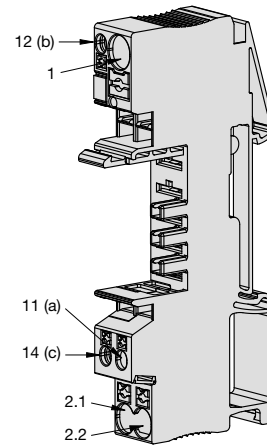

1	Supply
2.1 / 2.2	Power distribution
11 (a)	
14 (c)	
12 (c)	

Cable cross section

	Cross section when opening the push-in terminal	Cable cross section directly pluggable	stripped wire length
terminal 1 (line)	- rigid: 0.5...6 mm ² - flexible: 0.5...6 mm ² - flexible with wire end ferrule: (with plastic sleeve) 0.5...6 mm ² (10 mm ²) - flexible with wire end ferrule: (without plastic sleeve) 0.5...6 mm ² - flexible with TWIN-wire end ferrule: 0.5...1 mm ²	- rigid: 1...6 mm ² - flexible with wire end ferrule: (with plastic sleeve) 0.5...6 mm ² (10 mm ²) - flexible with wire end ferrule: (without plastic sleeve) 0.5...6 mm ²	12 mm
terminals 2.1 and 2.2 (load)	- rigid: 0.2...6 mm ² - flexible: 0.2...4 mm ² - flexible with wire end ferrule: (with plastic sleeve) 0.25...4 mm ² - flexible with wire end ferrule: (without plastic sleeve) 0.25...4 mm ² - flexible with TWIN-wire end ferrule: 0.5...1 mm ²	- rigid: 0.5...6 mm ² - flexible with wire end ferrule: (with plastic sleeve) 0.75...4 mm ² - flexible with wire end ferrule: (without plastic sleeve) 0.5...4 mm ²	12 mm
terminals 11, 12 and 14 (signalling)	- rigid: 0.14...1.5 mm ² - flexible: 0.14...1.5 mm ² - flexible with wire end ferrule: (with plastic housing) 0.14...1.5 mm ² - flexible with wire end ferrule: (without plastic sleeve) 0.14...1 mm ²	- rigid: 0.25...1.5 mm ² - flexible with wire end ferrule: (with plastic housing) 0.34...1.5 mm ² - flexible with wire end ferrule: (without plastic sleeve) 0.34...1 mm ²	8 mm

Insertion of busbars/jumpers

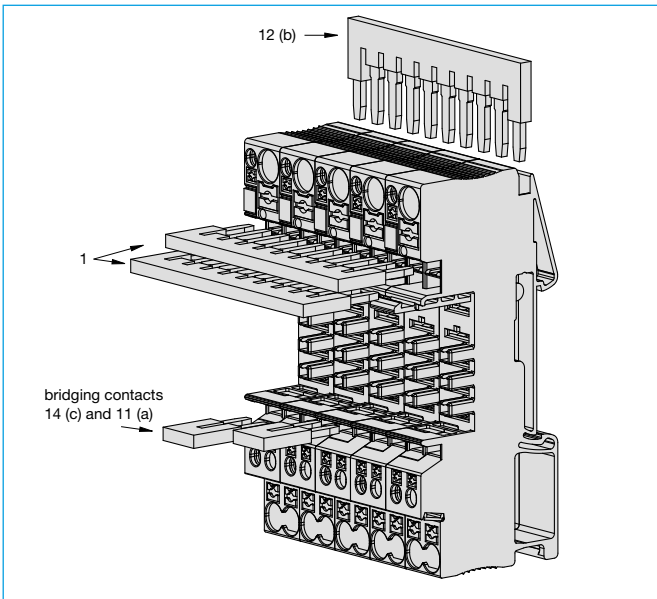

Coding of circuit breaker 2216-S and socket 80plus following the lock-key-principle

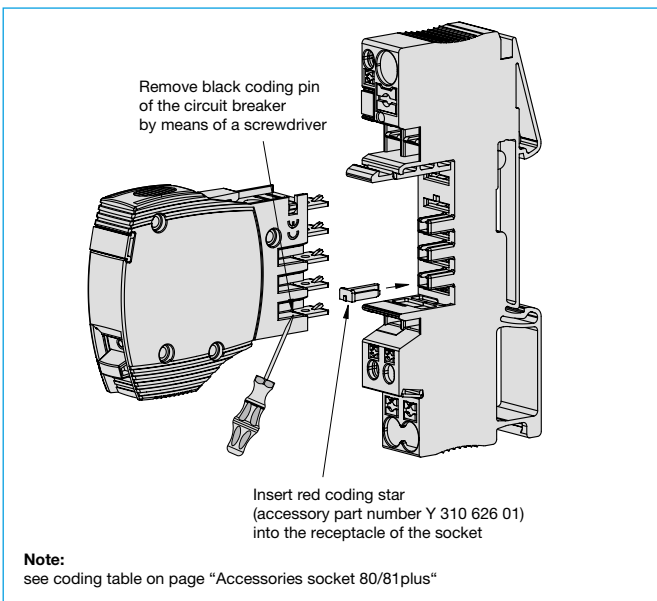

Replacing a circuit breaker

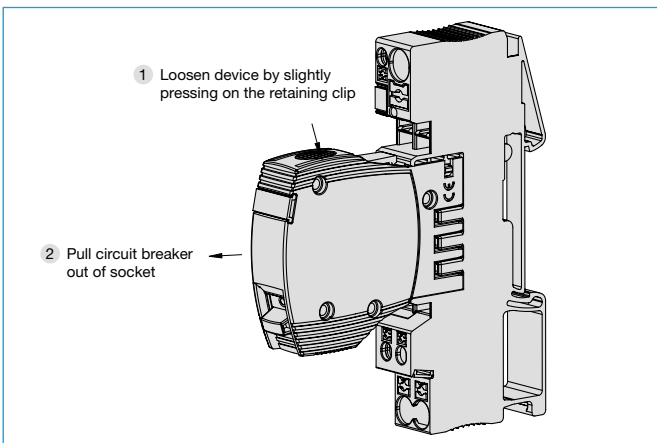

Application examples

Common line entry

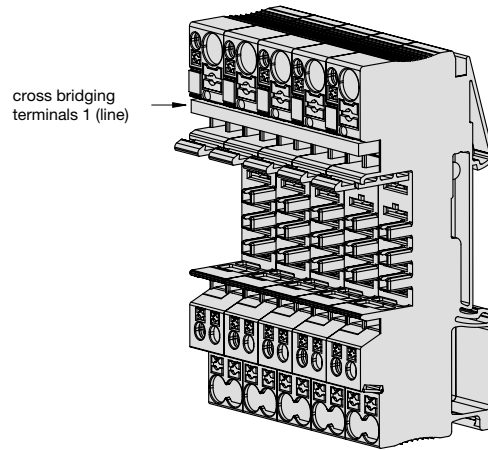

Series connection of auxiliary contacts

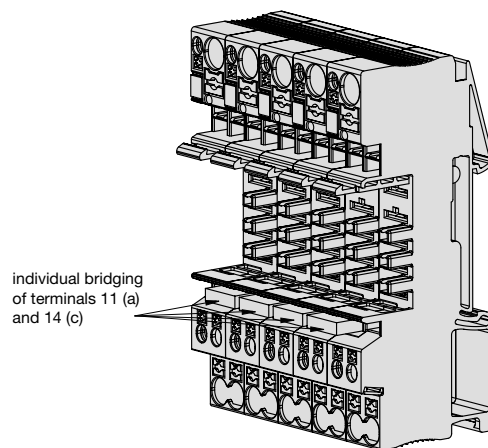

Parallel connection of auxiliary contacts

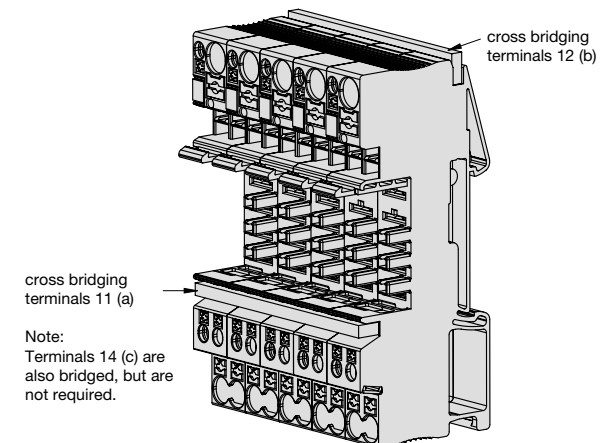

Description

Single pole, with screw terminals, to accommodate 1- and 2- pole circuit breakers type 2216-S

Part number: 81PLUS-UT01

Dimensions

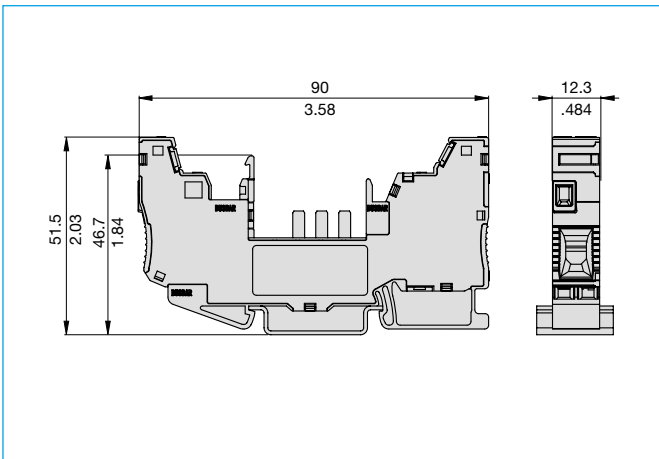

Line connection

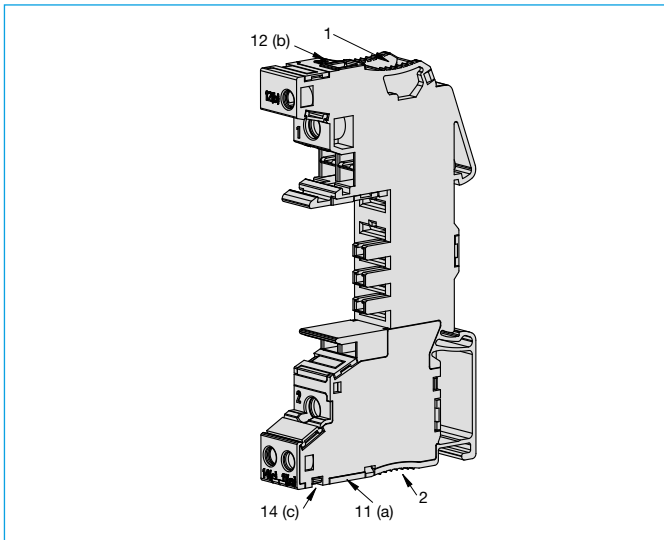

1	Supply
2	Power distribution
11 (a)	Change-over contact 
14 (c)	
12 (c)	

Cable cross section

	thread size	max. cable cross section		stripped wire length	tightening torque
terminals 1 (line) and 2 (load)	M4	Wire - rigid (single-wire or multistrand) 0.5...16 mm ² - flexible: 0.5...10 mm ² - flexible with wire end ferrule: (with and without plastic sleeve) 0.5...10 mm ² - flexible with TWIN-wire end ferrule: 0.5...6 mm ² Multi-lead connection (two wires with identical cross section) - rigid (single-wire or multistrand) 0.5...4 mm ² - flexible: 0.5...4 mm ² - flexible with TWIN-wire end ferrule (without plastic sleeve) 0.5...2.5 mm ²		10 mm	1.2 Nm
terminals 11, 12 and 14 (signalling)	M3	Wire - rigid: 0.14...4 mm ² - flexible: 0.14...4 mm ² - flexible with wire end ferrule: (with and without plastic sleeve) 0.14...2.5 mm ² Multi-lead connection (two wires with identical cross section) - rigid: 0.14...1.5 mm ² - flexible: 0.14...1.5 mm ² - flexible with TWIN AEH: (with plastic sleeve) 0.5...1.5 mm ² - flexible with AEH: (without plastic sleeve) 0.14...1.5 mm ²		9 mm	0.5 Nm

This is a metric design and millimeter dimensions take precedence ($\frac{mm}{inch}$)

All dimensions without tolerances are for reference only. In the interest of improved design, performance and cost effectiveness the right to make changes in these specifications without notice is reserved. Product markings may not be exactly as the ordering codes. Errors and omissions excepted.

Insertion of busbars/jumpers

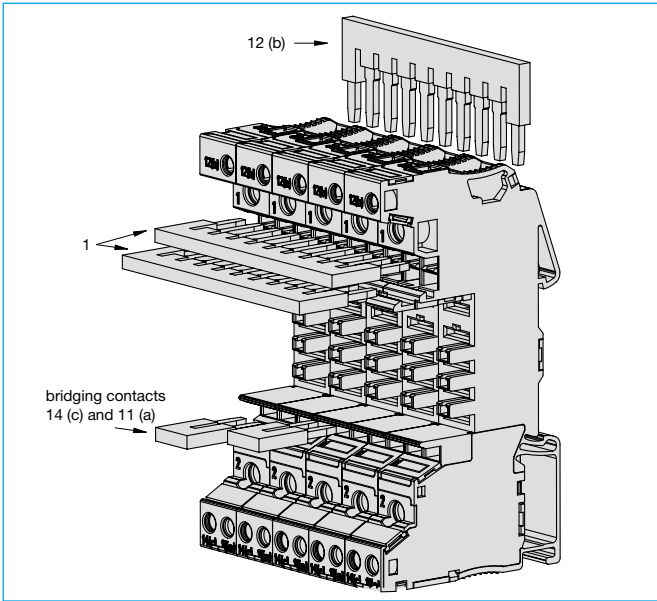

Coding of circuit breaker 2216-S and socket 81plus following the lock-key-principle

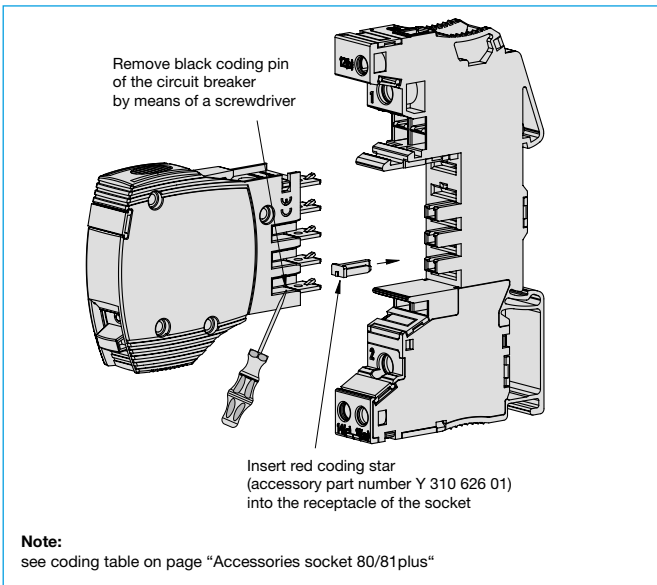

Replacing a circuit breaker

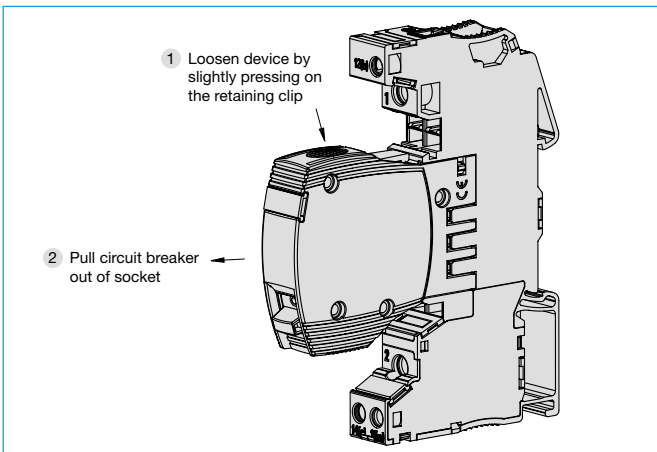

Application examples

Common line entry

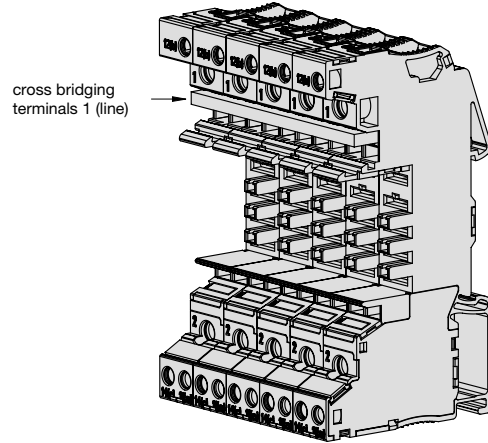

Series connection of auxiliary contacts

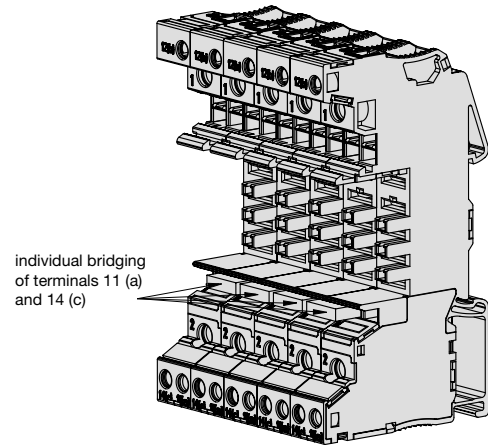

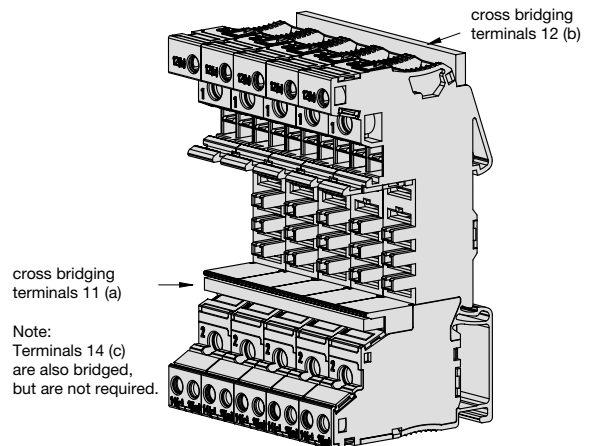

Parallel connection of auxiliary contacts



Accessories

Accessories for Socket 80plus and Socket 81plus	part number	packing qty
busbar, for cross-bridging in the bridge shaft, red, 2 poles *	Y 310 624 01	50
busbar, for cross-bridging in the bridge shaft, red, 4 poles *	Y 310 625 01	50
busbar, for cross-bridging in the bridge shaft, red, 10 poles *	Y 308 823 11	10
busbar, for cross-bridging in the bridge shaft, blue, 2 poles *	Y 310 624 02	50
busbar, for cross-bridging in the bridge shaft, blue, 4 poles *	Y 310 625 02	50
busbar, for cross-bridging in the bridge shaft, blue, 10 poles *	Y 308 823 12	10
busbar, for cross-bridging in the bridge shaft, grey, 2 poles *	Y 310 624 03	50
busbar, for cross-bridging in the bridge shaft, grey, 10 poles *	Y 308 823 13	10
coding star, red, with 4 coding pins each	Y 310 626 01	50
label	X 222 977 50	50

busbar/jumper, 10 poles 	coding star 	label 
---	---	---

* Max. bridge current: 32 A

When using two busbars/jumpers (in both bridge shafts of terminal 1), the max. current capacity is 41 A.

Caution:

When using busbars/jumpers for bridging the aux. contacts (11(a), 12(b) and 14(c)), the max. bridge current is 4 A

Coding table

Coding example:

Avoid hazardous oversize current ratings

Your benefit:

Coded circuit breakers can no longer be inserted into slots with a lower current rating coding.

Coding of circuit breakers and sockets

Sockets: Insert coding pins in accordance with coding table into receptacles of the sockets.

Circuit breakers: Remove coding pins in accordance with coding table by means of screw driver.

Breaker-socket-coding for the circuit protector with the **highest** current rating

decreasing current rating

Breaker-socket-coding for the circuit protector with the **lowest** current rating

Coding table	Example
Breaker 1 1 1	10 A
Socket 0 0 0	
Breaker 1 1 0	8 A
Socket 0 0 1	
Breaker 1 0 1	6 A
Socket 0 1 0	
Breaker 1 0 0	4 A
Socket 0 1 1	
Breaker 0 1 1	3 A
Socket 1 0 0	
Breaker 0 1 0	2 A
Socket 1 0 1	
Breaker 0 0 1	1 A
Socket 1 1 0	
Breaker 0 0 0	0.5 A
Socket 1 1 1	

1: With PIN / 0: No PIN

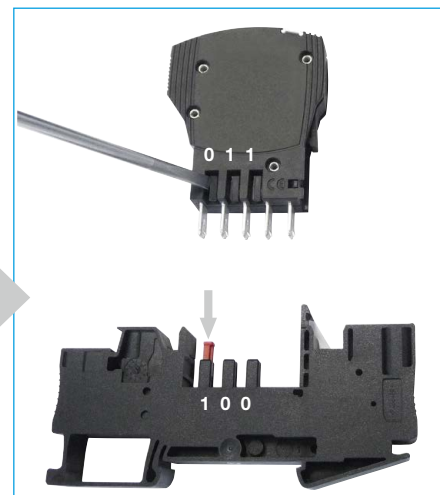

Компания «Life Electronics» занимается поставками электронных компонентов импортного и отечественного производства от производителей и со складов крупных дистрибьюторов Европы, Америки и Азии.

С конца 2013 года компания активно расширяет линейку поставок компонентов по направлению коаксиальный кабель, кварцевые генераторы и конденсаторы (керамические, пленочные, электролитические), за счёт заключения дистрибьюторских договоров

Мы предлагаем:

- Конкурентоспособные цены и скидки постоянным клиентам.
- Специальные условия для постоянных клиентов.
- Подбор аналогов.
- Поставку компонентов в любых объемах, удовлетворяющих вашим потребностям.
- Приемлемые сроки поставки, возможна ускоренная поставка.
- Доставку товара в любую точку России и стран СНГ.
- Комплексную поставку.
- Работу по проектам и поставку образцов.
- Формирование склада под заказчика.
- Сертификаты соответствия на поставляемую продукцию (по желанию клиента).
- Тестирование поставляемой продукции.
- Поставку компонентов, требующих военную и космическую приемку.
- Входной контроль качества.
- Наличие сертификата ISO.

В составе нашей компании организован Конструкторский отдел, призванный помогать разработчикам, и инженерам.

Конструкторский отдел помогает осуществить:

- Регистрацию проекта у производителя компонентов.
- Техническую поддержку проекта.
- Защиту от снятия компонента с производства.
- Оценку стоимости проекта по компонентам.
- Изготовление тестовой платы монтаж и пусконаладочные работы.



Тел: +7 (812) 336 43 04 (многоканальный)

Email: org@lifeelectronics.ru