



Ideal for thin LED lighting-module applications, Molex's Lite-Trap™ SMT wire-to-board connectors offer a low profile, easy wire removal, and low wire insertion and high wire retention forces.

The termination method of Molex's Lite-Trap connector is similar to Molex's Wire Trap connectors. A stripped wire is inserted into the connector and pushes open a gate-style terminal that "traps" the wire. To unmate, a button-style lever on the housing top is pushed down to allow the wire to be disengaged.

With a profile height of just 4.20mm, Molex's Lite-Trap connectors offer the lowest profile available of similar wire-removable types. Other lower-profile versions are available in the market, but these are permanent one-time connection types that do not allow wire removal.

Molex's wire-removable Lite-Trap connector offers lower wire insertion force than similar types. It also offers a user-friendly latch that is easy for operators to engage and disengage, even without the use of a tool. These features combine to offer easy field assembly and removal if needed for trained or untrained operators.

Other features of the Lite-Trap connector include a housing design that accepts more insulation-length range than competitive designs. This provides more stable wire seating for electrical contact assurance. The dual-contact wire-trap clamp design provides further mating assurance.

PRELIMINARY

Lite-Trap™ SMT Wire-to-Board Connector System, Push-Button Type

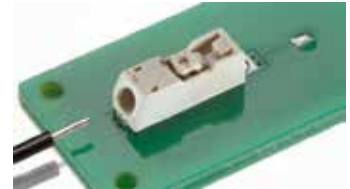

One-Circuit Type

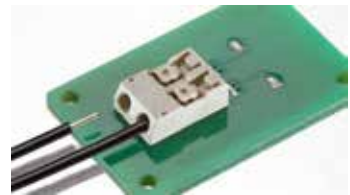

Two-Circuit Type

Features and Benefits

Low profile (4.20mm)	Meets needs of thin LED modules and other compact applications
User-friendly push-button latch	Ensures easy wire extraction
Dual-contact gate-style terminal design	Enables secure electrical contact and high wire-retention force
Long wire insulation design	Provides stable wire placement for additional contact assurance
Compact industry-standard PCB pattern layout	Saves space and is drop-in compatible with certain competitive products
Wire stopper feature	Facilitates correct wire insertion depth placement

Markets and Applications

- > Lighting
 - Down Light
 - Strip Light
- > Factory Automation Equipment
- > Consumer Electronics
- > Any application requiring an easy-to-use wire insertion/extraction method

> LED Down Lighting

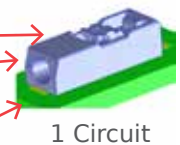

1 Circuit

> LED Strip Lighting



2 Circuit

Specifications

REFERENCE INFORMATION

Packaging: Embossed tape
Designed in: mm
AWG: 18-24 (Solid wire)
RoHS Compliant: Yes
Halogen Free: Yes

MECHANICAL

Wire Insertion Force:
15.0N (initial) max.
Wire Extraction Force:
AWG 24: 28.0N min.
AWG 18-22: 50.N min.

ELECTRICAL

Current: 9.0A max.
Voltage: 300V max.
Contact Resistance:
10 milliohms max.
Insulation Resistance:
1,000 Megohms min.
Dielectric Withstanding Voltage:
1,600 VAC for 1 minute

PHYSICAL

Connector: LCP, UL 94V-0, White
Terminal: Phosphor Bronze
Plating: Tin

Dimensional Overview

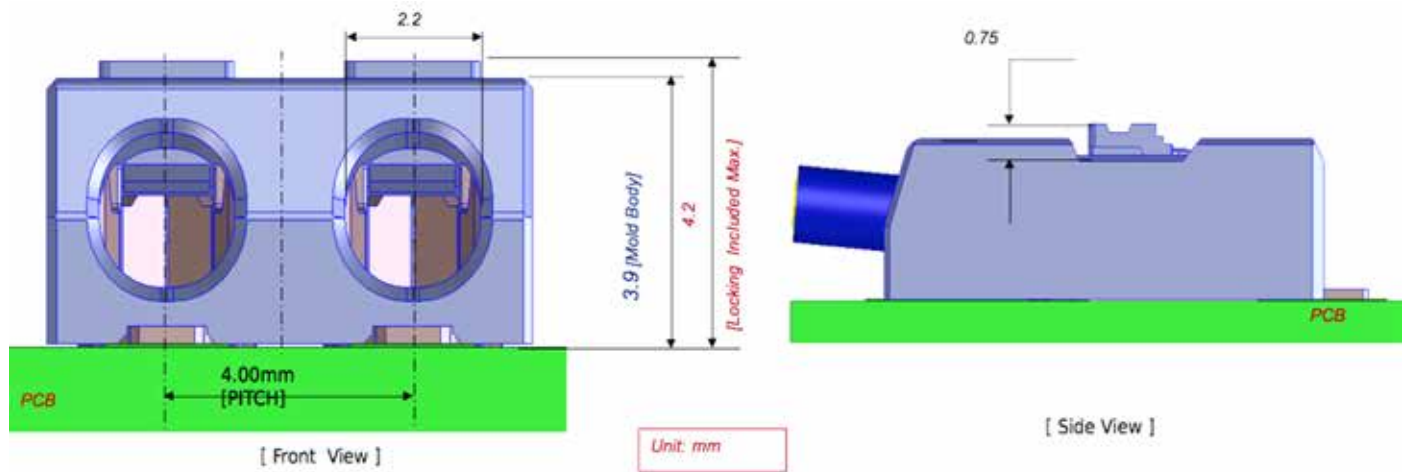

Molex's Lite-Trap™ connectors offer an overall compact size, with the lowest profile available in the industry for wire-removable styles.

Additional Product Features

How the Lite-Trap™ Connector Works

Wire Insertion

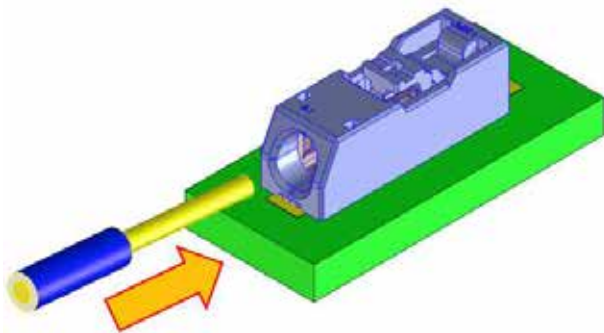

Wire is directly inserted and pushes open low-insertion force gate-style terminal, which "traps" wire in place

Wire Extraction

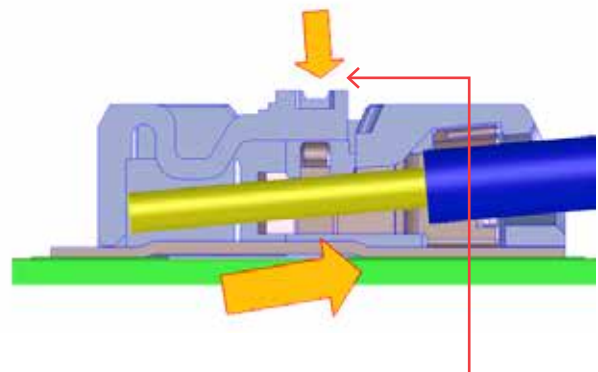

Button-style lever is pushed down, gate-style terminal opens, and wire can be freely pulled out.

www.molex.com/product/litetrp.html

Компания «Life Electronics» занимается поставками электронных компонентов импортного и отечественного производства от производителей и со складов крупных дистрибьюторов Европы, Америки и Азии.

С конца 2013 года компания активно расширяет линейку поставок компонентов по направлению коаксиальный кабель, кварцевые генераторы и конденсаторы (керамические, пленочные, электролитические), за счёт заключения дистрибьюторских договоров

Мы предлагаем:

- Конкурентоспособные цены и скидки постоянным клиентам.
- Специальные условия для постоянных клиентов.
- Подбор аналогов.
- Поставку компонентов в любых объемах, удовлетворяющих вашим потребностям.
- Приемлемые сроки поставки, возможна ускоренная поставка.
- Доставку товара в любую точку России и стран СНГ.
- Комплексную поставку.
- Работу по проектам и поставку образцов.
- Формирование склада под заказчика.
- Сертификаты соответствия на поставляемую продукцию (по желанию клиента).
- Тестирование поставляемой продукции.
- Поставку компонентов, требующих военную и космическую приемку.
- Входной контроль качества.
- Наличие сертификата ISO.

В составе нашей компании организован Конструкторский отдел, призванный помогать разработчикам, и инженерам.

Конструкторский отдел помогает осуществить:

- Регистрацию проекта у производителя компонентов.
- Техническую поддержку проекта.
- Защиту от снятия компонента с производства.
- Оценку стоимости проекта по компонентам.
- Изготовление тестовой платы монтаж и пусконаладочные работы.



Тел: +7 (812) 336 43 04 (многоканальный)

Email: org@lifeelectronics.ru