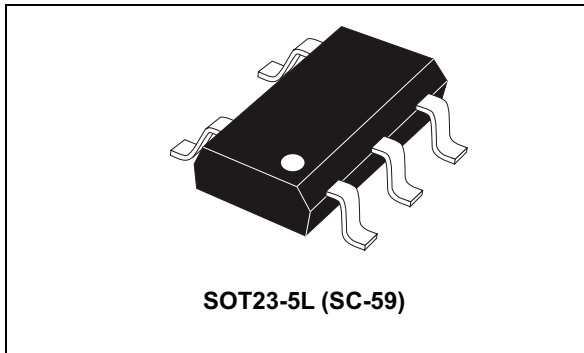


## Low capacitance TVS for high speed lines such as xDSL

Datasheet - production data



### Description

DSL02 is designed to protect DSL line drivers against surges defined in worldwide telecommunication standards. This device protects line drivers of various systems such as ADSL and VDSL. The low capacitance makes it suitable from ADSL to VDSL data rates.

DSL02 is able to survive severe conditions even when used with downgraded or oscillating gas tube.

DSL02 is also suitable to be used on other lines when IEC61000-4-5 surge capability is required.

DSL02 is packaged in a SOT23-5L.

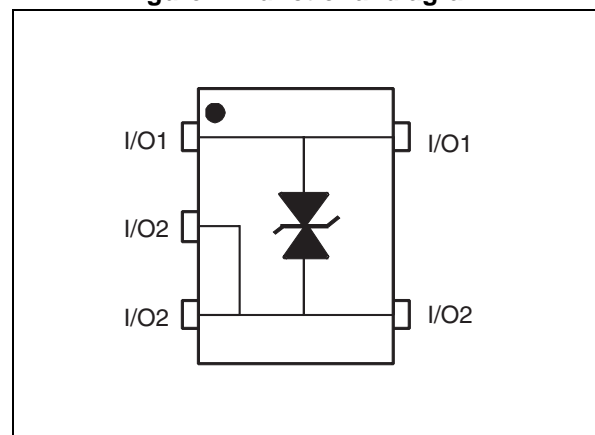
### Features

- High surge capability to comply with GR-1089 and ITU-T K20/21
- Keeps its peak power capability up to  $T_j$  max
- Stand-off voltage: 5 V, 8 V, 10 V
- Low capacitance device:  $C_{typ} = 3$  pF
- RoHS package
- Low leakage current: 0.5  $\mu$ A at 25 °C

### Complies with the following standards

- Telcordia GR-1089
  - 2.5 kV 2/10  $\mu$ s - 500 A 2/10  $\mu$ s
  - AC power fault tests
- ITU-T K20/21/45
  - 6 kV 10/700  $\mu$ s - 150 A 5/310  $\mu$ s
  - power induction tests
  - power contact tests
- IEC 61000-4-2, level 4
  - 15 kV (air discharge)
  - 8 kV (contact discharge)
- IEC 61000-4-5, level 3
  - $\pm$ 2 kV, 42  $\Omega$
- MIL STD 883G-Method 3015-7: Class 3
  - 8 kV (human body model)

**Figure 1. Functional diagram**



# 1 Characteristics

**Table 1. Absolute ratings ( $T_{amb} = 25\text{ °C}$ )**

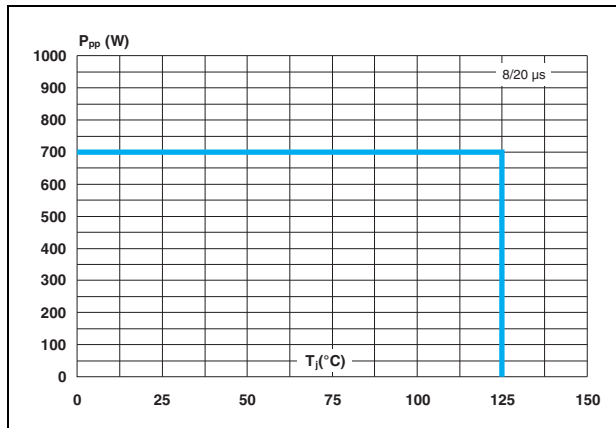
Symbol	Parameter		Value	Unit
$V_{PP}$	Peak pulse voltage	IEC 61000-4-2, contact discharge	30	kV
$I_{pp}$	Peak pulse current	8/20 $\mu$ s	30	A
$T_{stg}$	Storage temperature range		-55 to 150	$^{\circ}\text{C}$
$T_j$	Operating junction temperature range		-40 to 125	$^{\circ}\text{C}$
$T_L$	Maximum temperature for soldering during 10 s		260	$^{\circ}\text{C}$

**Table 2. Electrical characteristics ( $T_{amb} = 25\text{ °C}$ )**

Order code	$I_{RM} @ V_{RM}$		$V_{BR} @ I_{BR}$		$V_{CL} @ I_{PP}$ (8/20 $\mu$ s)		C		$\Delta C$
	Max. $\mu$ A	V	Min. V	mA	Max. V	A	Typ. pF <sup>(1)</sup>	Max. pF <sup>(1)</sup>	Typ. pF <sup>(2)</sup>
DSL02-005SC5	0.5	5	6	1	18	24	3	5	0.3
DSL02-008SC5	0.5	8	10	1	22	24	3	5	0.3
DSL02-010SC5	0.5	10	11	1	24	24	3	5	0.3

1. Test conditions:  $V_R = 2\text{ V}$  bias,  $V_{RMS} = 1\text{ V}$ ,  $F = 1\text{ MHz}$
2. Measured between 1 V and  $V_{RM}$

**Figure 2. Peak pulse power dissipation versus initial junction temperature (typical values, 8/20 $\mu$ s)**



**Figure 3. Leakage current versus junction temperature (typical values)**

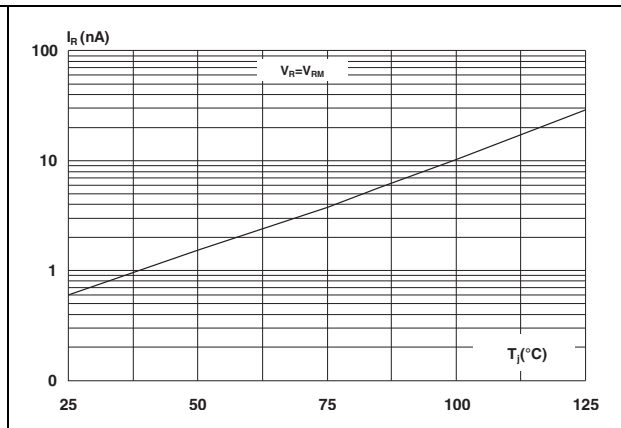


Figure 4. Junction capacitance versus reverse voltage applied (typical values)

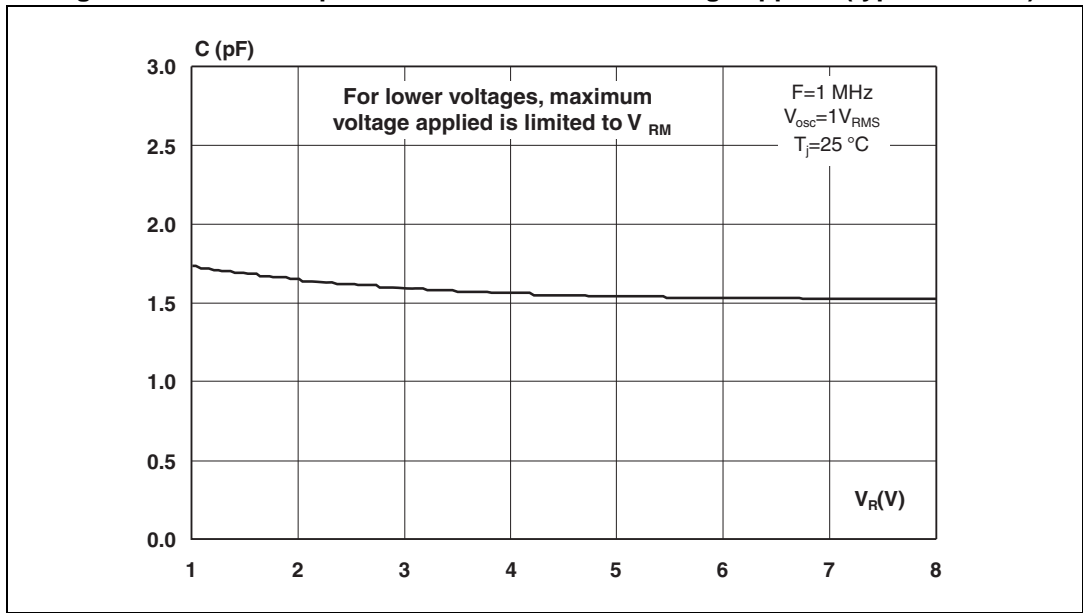
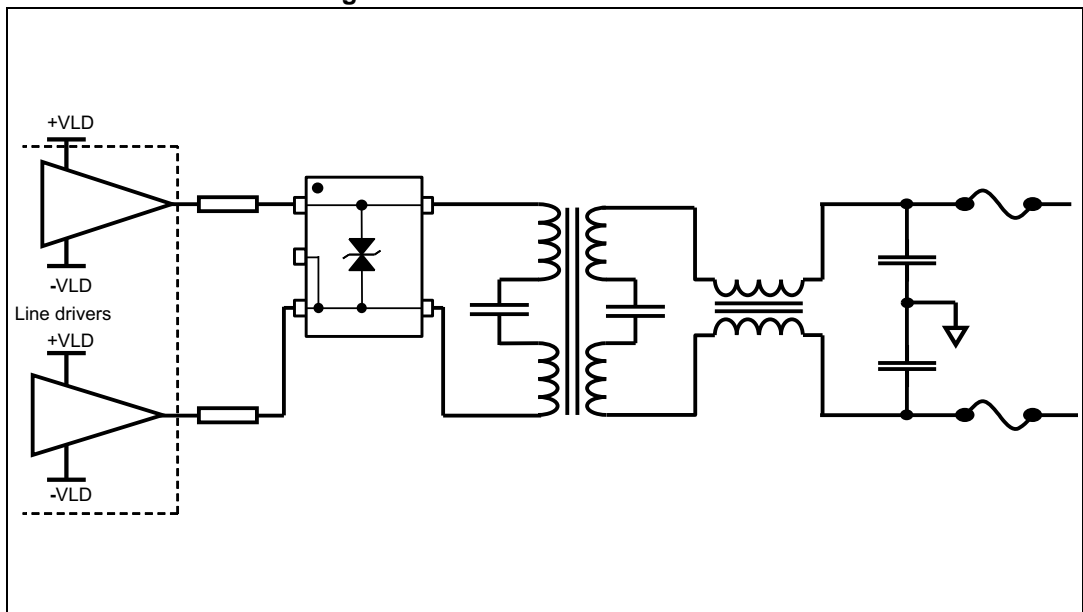


Figure 5. xDSL2 modem connection



## 2 Package information

- Epoxy meets UL94, V0
- Lead-free package

In order to meet environmental requirements, ST offers these devices in different grades of ECOPACK<sup>®</sup> packages, depending on their level of environmental compliance. ECOPACK<sup>®</sup> specifications, grade definitions and product status are available at: [www.st.com](http://www.st.com). ECOPACK<sup>®</sup> is an ST trademark.

Figure 6. SOT23-5L dimension definitions

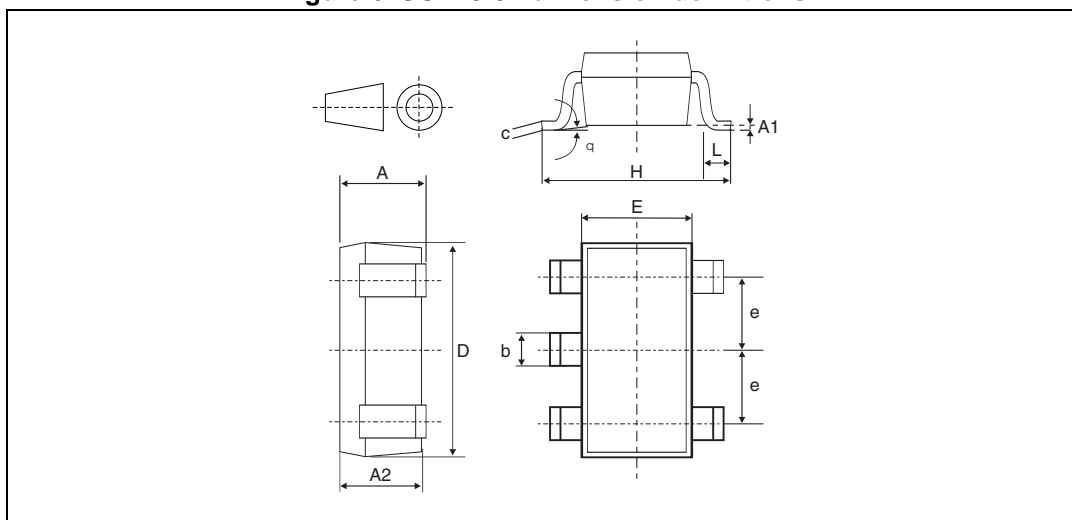
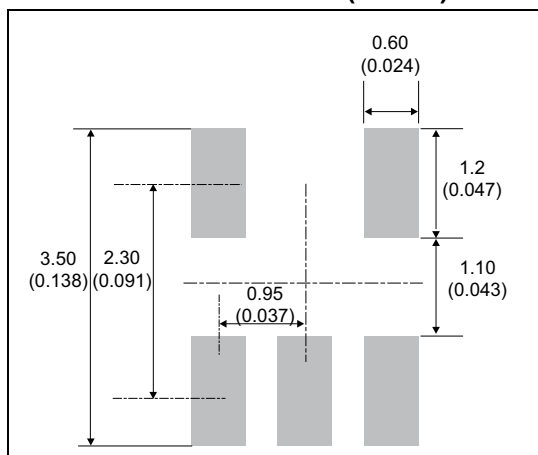


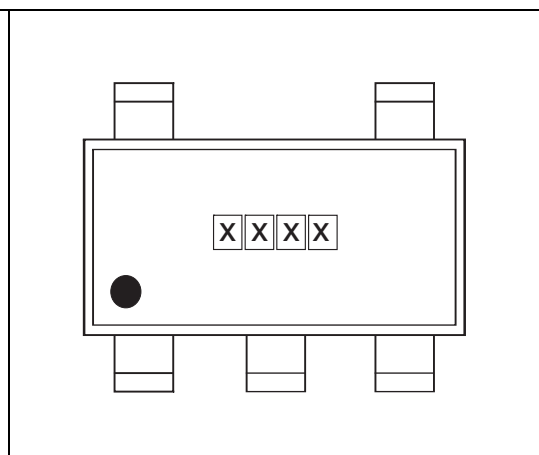
Table 3. SOT23-5L dimension values

Ref.	Dimensions					
	Millimeters			Inches		
	Min.	Typ.	Max.	Min.	Typ.	Max.
A	0.90		1.45	0.035		0.057
A1	0		0.15	0		0.006
A2	0.90		1.30	0.035		0.051
b	0.30		0.50	0.012		0.020
c	0.09		0.20	0.004		0.008
D	2.80		3.05	0.11		0.118
E	1.50		1.75	0.059		0.069
e		0.95			0.037	
H	2.60		3.00	0.102		0.118
L	0.30		0.60	0.012		0.024
M	0°		10°	0°		10°

**Figure 7. Footprint recommendations dimensions in mm (inches)**

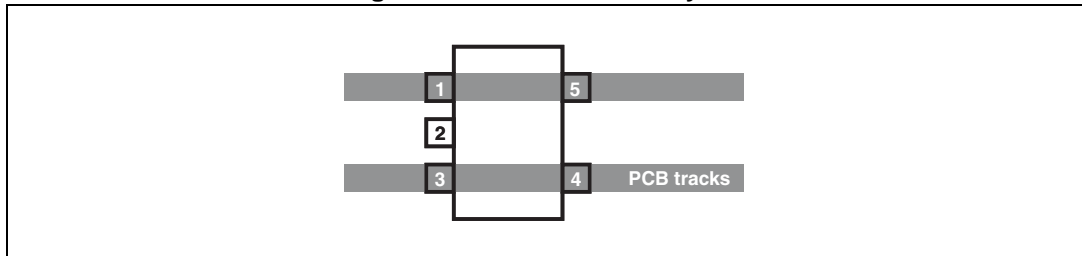


**Figure 8. Marking layout**



### 3 PCB recommendation

Figure 9. Recommended layout



Concerning [Figure 9](#):

- Pins 1 and 5 must be connected together.
- Pins 3 and 4 must be connected together.
- Pin 2 must not be connected

## 4 Ordering information

Figure 10. Ordering information scheme

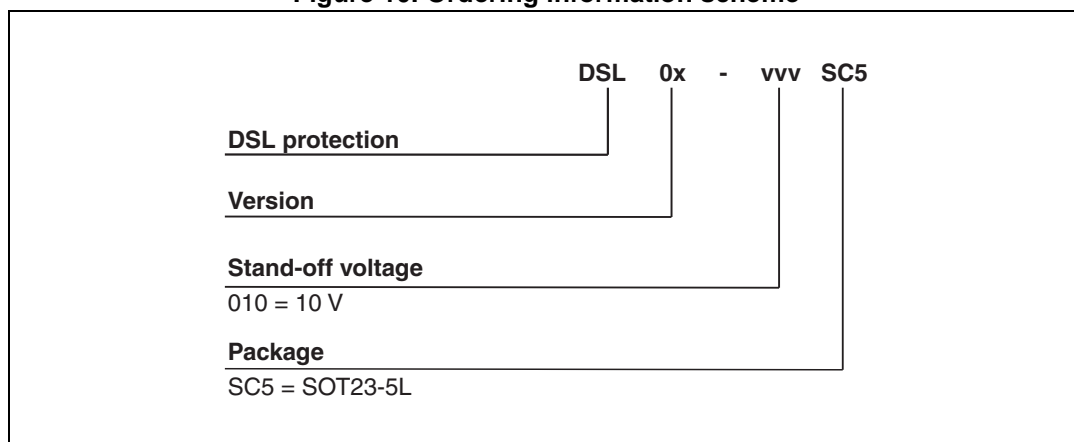


Table 4. Ordering information

Order code	Marking	Package	Weight	Base qty	Delivery mode
DSL02-005SC5	YT05	SOT23-5L	16 mg	3000	Tape and reel
DSL02-008SC5	YT08				
DSL02-010SC5	YT10				

## 5 Revision history

Table 5. Document revision history

Date	Revision	Changes
30-Oct-2013	1	Initial release.
03-Feb-2015	2	Updated <a href="#">Features</a> and <a href="#">Description</a> . Added <a href="#">Figure 5</a> .

**IMPORTANT NOTICE – PLEASE READ CAREFULLY**

STMicroelectronics NV and its subsidiaries ("ST") reserve the right to make changes, corrections, enhancements, modifications, and improvements to ST products and/or to this document at any time without notice. Purchasers should obtain the latest relevant information on ST products before placing orders. ST products are sold pursuant to ST's terms and conditions of sale in place at the time of order acknowledgement.

Purchasers are solely responsible for the choice, selection, and use of ST products and ST assumes no liability for application assistance or the design of Purchasers' products.

No license, express or implied, to any intellectual property right is granted by ST herein.

Resale of ST products with provisions different from the information set forth herein shall void any warranty granted by ST for such product.

ST and the ST logo are trademarks of ST. All other product or service names are the property of their respective owners.

Information in this document supersedes and replaces information previously supplied in any prior versions of this document.

© 2015 STMicroelectronics – All rights reserved



Компания «Life Electronics» занимается поставками электронных компонентов импортного и отечественного производства от производителей и со складов крупных дистрибьюторов Европы, Америки и Азии.

С конца 2013 года компания активно расширяет линейку поставок компонентов по направлению коаксиальный кабель, кварцевые генераторы и конденсаторы (керамические, пленочные, электролитические), за счёт заключения дистрибьюторских договоров

Мы предлагаем:

- Конкурентоспособные цены и скидки постоянным клиентам.
- Специальные условия для постоянных клиентов.
- Подбор аналогов.
- Поставку компонентов в любых объемах, удовлетворяющих вашим потребностям.
- Приемлемые сроки поставки, возможна ускоренная поставка.
- Доставку товара в любую точку России и стран СНГ.
- Комплексную поставку.
- Работу по проектам и поставку образцов.
- Формирование склада под заказчика.
- Сертификаты соответствия на поставляемую продукцию (по желанию клиента).
- Тестирование поставляемой продукции.
- Поставку компонентов, требующих военную и космическую приемку.
- Входной контроль качества.
- Наличие сертификата ISO.

В составе нашей компании организован Конструкторский отдел, призванный помогать разработчикам, и инженерам.

Конструкторский отдел помогает осуществить:

- Регистрацию проекта у производителя компонентов.
- Техническую поддержку проекта.
- Защиту от снятия компонента с производства.
- Оценку стоимости проекта по компонентам.
- Изготовление тестовой платы монтаж и пусконаладочные работы.



Тел: +7 (812) 336 43 04 (многоканальный)

Email: [org@lifeelectronics.ru](mailto:org@lifeelectronics.ru)