

EMD-FL-PF-400

Electronic monitoring relay for load monitoring in single and three-phase networks, based on the power factor $\cos \varphi$

INTERFACE

Data sheet
102914_en_02

© PHOENIX CONTACT - 09/2009



1 Description

Increasingly higher demands are being placed on safety and system availability – across all sectors. Processes are becoming more and more complex, not only in mechanical engineering and the chemical industry, but also in plant and automation technology. Demands on power engineering are also increasing constantly.

Error-free and therefore cost-effective operation can only be achieved through continuous monitoring of important network and system parameters. Electronic monitoring relays in the EMD series are available for a wide range of monitoring tasks to avoid the consequences of errors or to keep them within limits.

The operating states are indicated using colored LEDs, errors that may occur can be sent to a control system via a floating contact or can shut down a part of the system. Some device versions are equipped with startup and response delays in order to briefly tolerate measured values outside the set monitoring range.

Features

- Overload monitoring
- Underload monitoring
- Window function
- Adjustable threshold values
- Adjustable starting override
- Adjustable response delay
- Error memory
- Wide-range power supply unit
- Two PDTs



WARNING: Risk of electric shock

Never carry out work when voltage is present.



Make sure you always use the the latest documentation.
It can be downloaded at www.phoenixcontact.net/download.

2 Ordering data

Description	Type	Order No.	Pcs. / Pkt.
Electronic monitoring relay for load monitoring in single and three-phase networks, based on the power factor $\cos \varphi$	EMD-FL-PF-400	2885809	1

3 Technical data

Input data	
Input name	Measuring input
Measured value	AC sine (10 ... 100 Hz)
Nominal input voltage U_N	(3 N ~ 415/240 V)
Input voltage range	1(N) ~ 40 V AC ... 415 V AC 3 (N) ~ 40 V AC ... 415 V AC
Maximum input voltage	(3 N ~ 500/289 V)
Input current range	0.5 A ... 10 A (Connection terminal blocks: L1i and L1k)
Overload capacity	12 A permanent
Input resistance of voltage input	$\geq 1 \text{ M}\Omega$
Input resistance current input	5 m Ω
Min. switching threshold $\cos \varphi$	0.1 ... 0.99
Max. switching threshold $\cos \varphi$	0.2 ... 1
Maximum temperature coefficient	$\leq 0.1 \text{ \%}/\text{K}$
Setting range for response delay	0.1 s ... 40 s
Setting range for starting delay	1 s ... 100 s
Function	Underload, overload, Window
Basic accuracy	$\pm 5 \text{ \%}$ (At $\cos \varphi = 0.8$)
Setting accuracy	$\leq 5 \text{ \%}$ (At $\cos \varphi = 0.8$)
Repeat accuracy	$\pm 1.8 \text{ \%}$
Recovery time	500 ms
Output data	
Contact type	2 floating PDT contacts
Nominal insulation voltage	250 V AC (in acc. with IEC 60664-1)
Interrupting rating (ohmic load) max.	750 VA (3 A/250 V AC, module aligned, $\leq 5 \text{ mm}$ spacing) 1250 VA (5 A/250 V AC, module not aligned, $\geq 5 \text{ mm}$ spacing)
Output fuse	5 A (fast-blow)
Supply	
Range of supply voltages	24 V AC ... 240 V AC -15 % ... +10 % 24 V DC ... 240 V DC -20 % ... +25 %
Frequency range	48 Hz ... 400 Hz
Nominal power consumption	4.5 VA (1.5 W)
General data	
Mains type	1 and 3-phase
Service life mechanical	Approx. 2×10^7 cycles
Service life, electrical	2×10^5 cycles at ohmic load, 1000 VA
Switching frequency	max. 60 (per minute at 100 VA ohmic load) max. 6 (per minute at 1000 VA ohmic load)
Operating mode	100% operating factor

General data (Continued)

Degree of protection	IP40 (housing) / IP20 (connection terminal blocks)
Pollution degree	2 (according to EN 50178)
Surge voltage category	III, basic insulation (as per EN 50178)
Rated insulation voltage	300 V (According to EN 50178)
Assembly	on TS 35 profile rail acc. to EN 60715
Mounting position	Any
Width	22.5 mm
Height	113 mm
Length	90 mm
Type of housing	Polyamide PA, self-extinguishing
Color	green
Weight	160 g

Connection data

Conductor cross section, solid	0.5 mm ² ... 2.5 mm ²
Conductor cross section, stranded	0.25 mm ² ... 2.5 mm ²
Stripping length	8 mm
Type of connection	Screw connection
Tightening torque	1 Nm

Ambient conditions

Ambient temperature (operation)	-25 °C ... 55 °C -25 °C ... 40 °C (corresponds to UL 508)
Ambient temperature (storage/transport)	-25 °C ... 70 °C
Permissible humidity (operation)	15 % ... 85 %
Climatic class	3K3 (in acc. with EN 60721)

Conformance / approvals

Conformity	CE compliant
UL, USA / Canada	UL/C-UL listed UL 508

Conformance with EMC directive 2004/108/EC

Immunity to interference according to	EN 61000-6-2
Emitted interference according to	EN 61000-6-4

Conformance with LV directive 2006/95/EC

Electronic equipm. for electrical power installations according to	EN 50178
--	----------

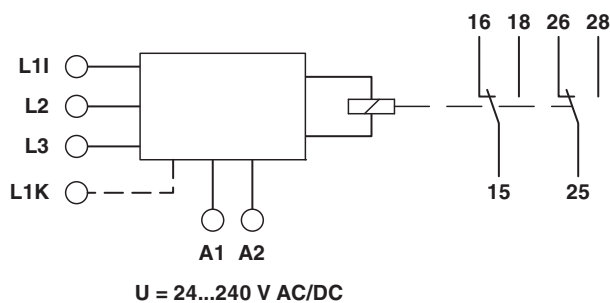
4 Block diagram

5 Safety notes



WARNING: Risk of electric shock
Never carry out work when voltage is present.

6 Structure

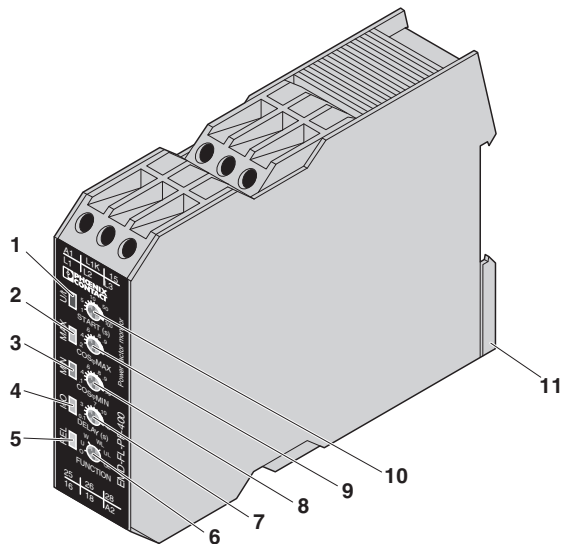

- 1 "U/t" LED: Supply voltage and starting override
- 2 "MAX" LED: Upper threshold value
- 3 "MIN" LED: Lower threshold value
- 4 "I=0" LED: Load switched off
- 5 "REL" LED: Output relay
- 6 "FUNCTION" rotary switch: Function selection
- 7 "DELAY" potentiometer: Response delay
- 8 "COS ϕ MIN" potentiometer: Lower threshold value
- 9 "COS ϕ MAX" potentiometer: Upper threshold value
- 10 "START" potentiometer: Starting override
- 11 Universal snap-on foot for EN DIN rails

7 Installation



WARNING: Risk of electric shock
Never carry out work when voltage is present.

The module can be snapped onto all 35 mm DIN rails according to EN 60715.

An integrated wide-range power supply unit enables the connection of a supply voltage in the range from 24 V AC/DC to 240 V AC/DC.

8 Diagnostics

The LEDs indicate the following error states:

"U/t" LED (Green)

- LED ON: Supply voltage present

"MIN" and "MAX" LEDs (Red)

- LED flashes: Set delay time is running
- LED ON: Delay time has elapsed
- Both LEDs flash alternately: Lower set threshold value is greater than upper threshold value

"I=0" LED (Yellow)

- LED ON: Load is switched off, no current flow between L1i and L1k

"REL" LED (Yellow)

- LED ON: Output relay has picked up
- LED OFF: Output relay has dropped out

9 Connection examples

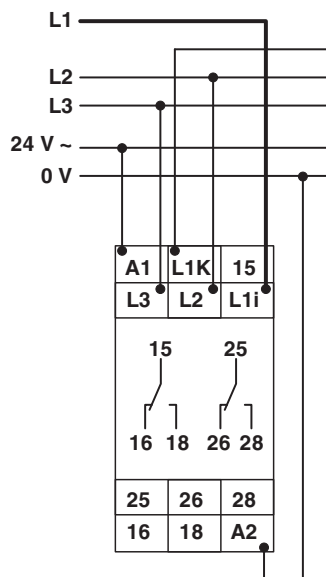

3 ~ 400 V measuring range, without error memory,
24 V AC supply voltage, $I_N < 10$ A

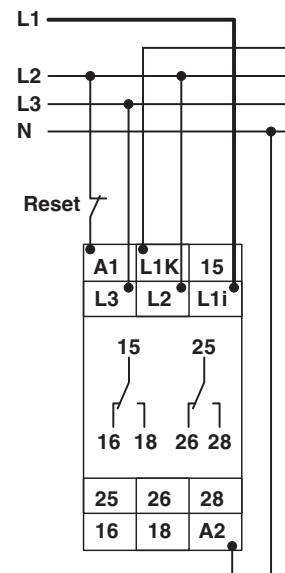

3 ~ 400 V measuring range, with error memory,
230 V AC supply voltage, $I_N < 10$ A

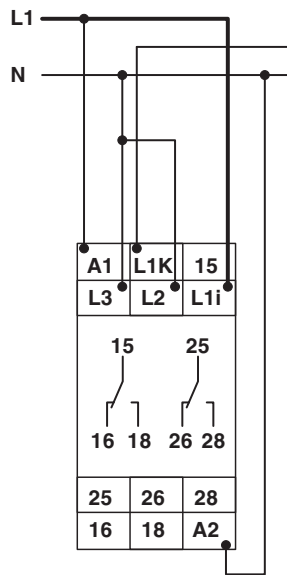

1 ~ 230 V measuring range, without error memory,
230 V AC supply voltage, $I_N < 10$ A

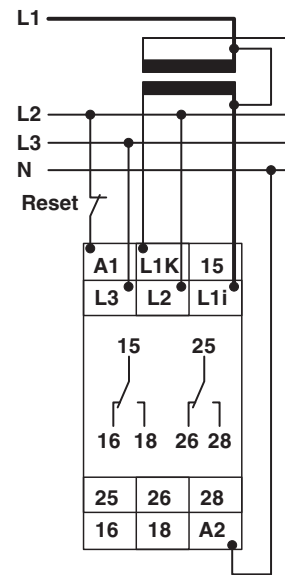

3 ~ 400 V measuring range, with error memory,
230 V AC supply voltage, $I_N > 10$ A

10 Function

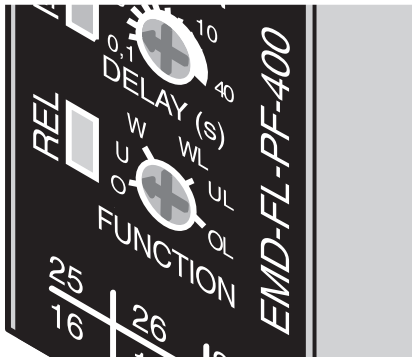

If an error is present when the monitoring module is activated, output relay "R" remains dropped out and the LED for the corresponding threshold value lights up.

For all functions the "MIN" and "MAX" LEDs flash alternately if the minimum value selected is greater than the maximum value.

The "FUNCTION" rotary switch is used to set the desired function:

- O = Overload monitoring (OVER)
- OL = Overload monitoring with error memory (OVER + LATCH)
- U = Underload monitoring (UNDER)
- UL = Underload monitoring with error memory (UNDER + LATCH)
- W = Monitoring of the area between thresholds MIN and MAX (window function) (WIN)
- WL = Monitoring of the area between thresholds MIN and MAX (window function) with error memory (WIN + LATCH)

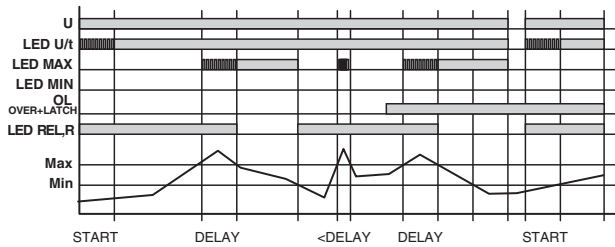

Overload Monitoring (OVER and OVER + LATCH)

If the measured power factor exceeds the value set at the "MAX" controller, the set response delay (DELAY) starts (red "MAX" LED flashes). After the delay time has elapsed (red "MAX" LED is ON), output relay "R" drops out (yellow "REL" LED is OFF). If the measured power factor falls below the value set at the "MIN" controller (red "MAX" LED is OFF), output relay "R" picks up again (yellow "REL" LED is ON). If the error memory has been activated (OVER + LATCH) and the measured power factor has exceeded the value set at the "MAX" controller for longer than the set response delay, output relay "R" does not pick up if the power factor falls below the value set at the "MIN" controller. Once the error has been reset (supply voltage interrupted, e.g., using an external button), output relay "R" picks up when the supply voltage is applied again and the measuring cycle starts again once the set starting override (START) has elapsed.

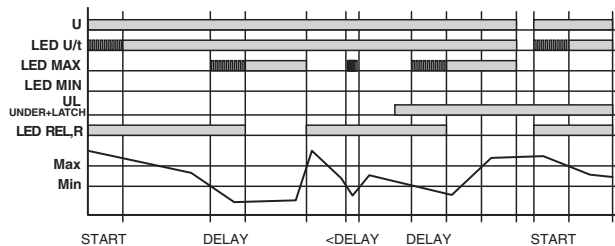

Underload Monitoring (UNDER and UNDER + LATCH)

If the measured power factor falls below the value set at the "MIN" controller, the set response delay (DELAY) starts (red "MIN" LED flashes). After the delay time has elapsed (red "MIN" LED is ON), output relay "R" drops out (yellow "REL" LED is OFF). If the measured power factor exceeds the value set at the "MAX" controller, output relay "R" picks up again (yellow "REL" LED is ON).

If the error memory has been activated (UNDER + LATCH) and the measured power factor has fallen below the value set at the "MIN" controller for longer than the set response delay, output relay "R" does not pick up if the power factor exceeds the value set at the "MAX" controller. Once the error has been reset (supply voltage interrupted, e.g., using an external button), output relay "R" picks up when the supply voltage is applied again and the measuring cycle starts again once the set starting override (START) has elapsed.

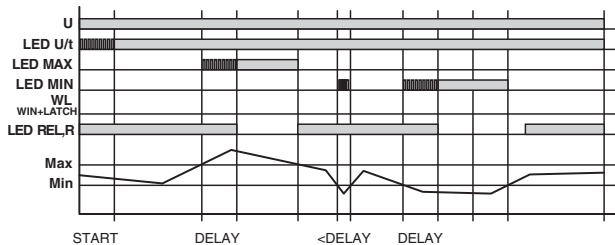

Window Function (WIN)

Output relay "R" picks up (yellow "REL" LED is ON) if the measured power factor exceeds the value set at the "MIN" controller. If the measured power factor exceeds the value set at the "MAX" controller, the set response delay (DELAY) starts (red "MAX" LED flashes). After the delay time has elapsed (red "MAX" LED is ON), output relay "R" drops out (yellow "REL" LED is OFF).

The output relay picks up again (yellow "REL" LED is ON) if the measured power factor falls below the maximum value again (red "MAX" LED is OFF). If the measured power factor falls below the value set at the "MIN" controller, the set response delay (DELAY) starts (red "MIN" LED flashes). After the delay time has elapsed (red "MIN" LED is ON), output relay "R" drops out (yellow "REL" LED is OFF).

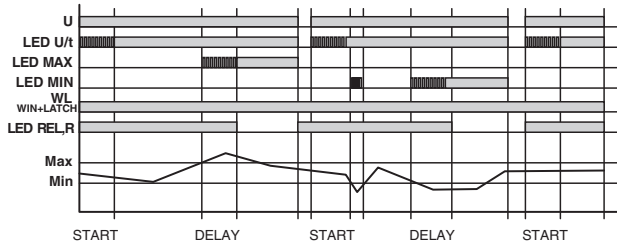

Window Function (WIN + LATCH)

If the error memory has been activated (WIN + LATCH), an error that has occurred must be reset by interrupting the supply voltage (e.g., using an external button). Output relay "R" then picks up when the supply voltage is applied again and the measuring cycle starts again once the set starting override (START) has elapsed.

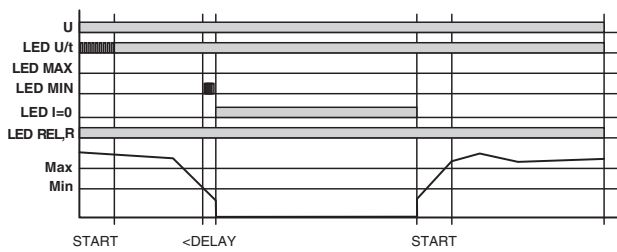

Detecting Switched Off Loads

If the current flow between L1i and L1k is interrupted (yellow "I=0" LED is ON) and no stored errors are present, output relay "R" picks up or remains picked up (yellow "REL" LED is ON). When the current flow is present again, the measuring cycle starts again once the set starting override (START) has elapsed.

Компания «Life Electronics» занимается поставками электронных компонентов импортного и отечественного производства от производителей и со складов крупных дистрибьюторов Европы, Америки и Азии.

С конца 2013 года компания активно расширяет линейку поставок компонентов по направлению коаксиальный кабель, кварцевые генераторы и конденсаторы (керамические, пленочные, электролитические), за счёт заключения дистрибьюторских договоров

Мы предлагаем:

- Конкурентоспособные цены и скидки постоянным клиентам.
- Специальные условия для постоянных клиентов.
- Подбор аналогов.
- Поставку компонентов в любых объемах, удовлетворяющих вашим потребностям.
- Приемлемые сроки поставки, возможна ускоренная поставка.
- Доставку товара в любую точку России и стран СНГ.
- Комплексную поставку.
- Работу по проектам и поставку образцов.
- Формирование склада под заказчика.
- Сертификаты соответствия на поставляемую продукцию (по желанию клиента).
- Тестирование поставляемой продукции.
- Поставку компонентов, требующих военную и космическую приемку.
- Входной контроль качества.
- Наличие сертификата ISO.

В составе нашей компании организован Конструкторский отдел, призванный помогать разработчикам, и инженерам.

Конструкторский отдел помогает осуществить:

- Регистрацию проекта у производителя компонентов.
- Техническую поддержку проекта.
- Защиту от снятия компонента с производства.
- Оценку стоимости проекта по компонентам.
- Изготовление тестовой платы монтаж и пусконаладочные работы.



Тел: +7 (812) 336 43 04 (многоканальный)

Email: org@lifeelectronics.ru