

High-side driver with CurrentSense analog feedback for automotive applications

Datasheet - production data



- Protections
 - Undervoltage shutdown
 - Overvoltage clamp
 - Load current limitation
 - Self limiting of fast thermal transients
 - Loss of ground and loss of V_{CC}
 - Reverse battery
 - Electrostatic discharge protection

Features

Max transient supply voltage	V_{CC}	40 V
Operating voltage range	V_{CC}	4 to 28 V
Typ. on-state resistance (per Ch)	R_{ON}	3.5 m Ω
Current limitation (typ)	I_{LIMH}	135 A
Stand-by current (max)	I_{STBY}	0.5 μ A
Minimum cranking supply voltage (V_{CC} decreasing)	$V_{USD_Cranking}$	3 V

- AEC-Q100 qualified
- Extreme low voltage operation for deep cold cranking applications (compliant with LV124, revision 2013)
- General
 - Single channel smart high-side driver with CurrentSense analog feedback
 - Very low standby current
 - Compatible with 3 V and 5 V CMOS outputs
- Diagnostic functions
 - Overload and short to ground (power limitation) indication
 - Thermal shutdown indication
 - OFF-state open-load detection
 - Output short to V_{CC} detection
 - Sense enable/ disable



Applications

Specially intended for Automotive smart power distribution, glow plugs, heating systems, DC motors, relay replacement and high power resistive and inductive actuators.

Description

The device is a single channel high-side driver manufactured using ST proprietary VIPower[®] technology and housed in the Octapak package. The device is designed to drive 12 V automotive grounded loads through a 3 V and 5 V CMOS-compatible interface, providing protection and diagnostics.

The device integrates advanced protective functions such as load current limitation, overload active management by power limitation and overtemperature shutdown.

A sense enable pin allows OFF-state diagnosis to be disabled during the module low-power mode as well as external sense resistor sharing among similar devices.

Table 1: Device summary

Package	Order codes
	Tape and reel
Octapak	VN7003AHTR

Contents

1	Block diagram and pin description	5
2	Electrical specification.....	7
2.1	Absolute maximum ratings	7
2.2	Thermal data	8
2.3	Electrical characteristics.....	8
2.4	Electrical characteristics curves	16
3	Protections.....	20
3.1	Power limitation	20
3.2	Thermal shutdown.....	20
3.3	Current limitation	20
3.4	Negative voltage clamp	20
4	Application information	21
4.1	Protection against reverse battery.....	21
4.2	Immunity against transient electrical disturbances	22
4.3	MCU I/Os protection.....	22
4.4	CS - analog current sense	23
4.4.1	Principle of CurrentSense signal generation	24
4.4.2	Short to VCC and OFF-state open-load detection	26
5	Maximum demagnetization energy (VCC = 16 V)	28
6	Package and PCB thermal data	29
6.1	Octapak thermal data	29
7	Package information	32
7.1	Octapak package information.....	32
7.2	Octapak packing information.....	33
7.3	Octapak marking information	35
8	Revision history	36

List of tables

Table 1: Device summary	1
Table 2: Pin functions	5
Table 3: Suggested connections for unused and not connected pins	6
Table 4: Absolute maximum ratings	7
Table 5: Thermal data	8
Table 6: Electrical characteristics during cranking	8
Table 7: Power section	9
Table 8: Switching	10
Table 9: Logic inputs	10
Table 10: Protection	11
Table 11: CurrentSense	11
Table 12: Truth table	15
Table 13: ISO 7637-2 - electrical transient conduction along supply line	22
Table 14: CurrentSense pin levels in off-state	26
Table 15: PCB properties	29
Table 16: Thermal parameters	31
Table 17: Octapak mechanical data	32
Table 18: Reel dimensions	34
Table 19: Document revision history	36

List of figures

Figure 1: Block diagram	5
Figure 2: Configuration diagram (top view).....	6
Figure 3: Current and voltage conventions.....	7
Figure 4: IOOUT/ISENSE versus IOOUT.....	13
Figure 5: Current sense precision vs. IOOUT	14
Figure 6: Switching times and Pulse skew	14
Figure 7: tDSTKON.....	15
Figure 8: OFF-state output current	16
Figure 9: Standby current	16
Figure 10: IGND(ON) vs. Iout	16
Figure 11: Logic input high level voltage	16
Figure 12: Logic input low level voltage.....	16
Figure 13: High level logic input current	16
Figure 14: Low level logic input current	17
Figure 15: Logic input hysteresis voltage	17
Figure 16: Undervoltage shutdown.....	17
Figure 17: On-state resistance vs. Tcase	17
Figure 18: On-state resistance vs. VCC	17
Figure 19: Turn-on voltage slope.....	17
Figure 20: Turn-off voltage slope.....	18
Figure 21: Won vs. Tcase.....	18
Figure 22: Woff vs. Tcase.....	18
Figure 23: ILIMH vs. Tcase.....	18
Figure 24: Turn-off output voltage clamp.....	18
Figure 25: OFF-state open-load voltage detection threshold	18
Figure 26: Vs clamp vs. Tcase	19
Figure 27: Vsenseh vs. Tcase	19
Figure 28: Application diagram	21
Figure 29: Simplified internal structure	21
Figure 30: CurrentSense and diagnostic – block diagram.....	23
Figure 31: CurrentSense block diagram	24
Figure 32: Analogue HSD – open-load detection in off-state	25
Figure 33: Open-load / short to VCC condition.....	26
Figure 34: Maximum turn off current versus inductance	28
Figure 35: Octapak on two-layers PCB (2s0p to JEDEC JESD 51-5).....	29
Figure 36: Octapak on four-layers PCB (2s2p to JEDEC JESD 51-7)	29
Figure 37: Rthj-amb vs PCB copper area in open box free air conditions	30
Figure 38: Octapak thermal impedance junction ambient single pulse	30
Figure 39: Thermal fitting model for Octapak	31
Figure 40: Octapak package dimensions	32
Figure 41: Octapack reel 13"	33
Figure 42: Octapak carrier tape	34
Figure 43: Octapak schematic drawing of leader and trailer tape	35
Figure 44: Octapak marking information.....	35

1 Block diagram and pin description

Figure 1: Block diagram

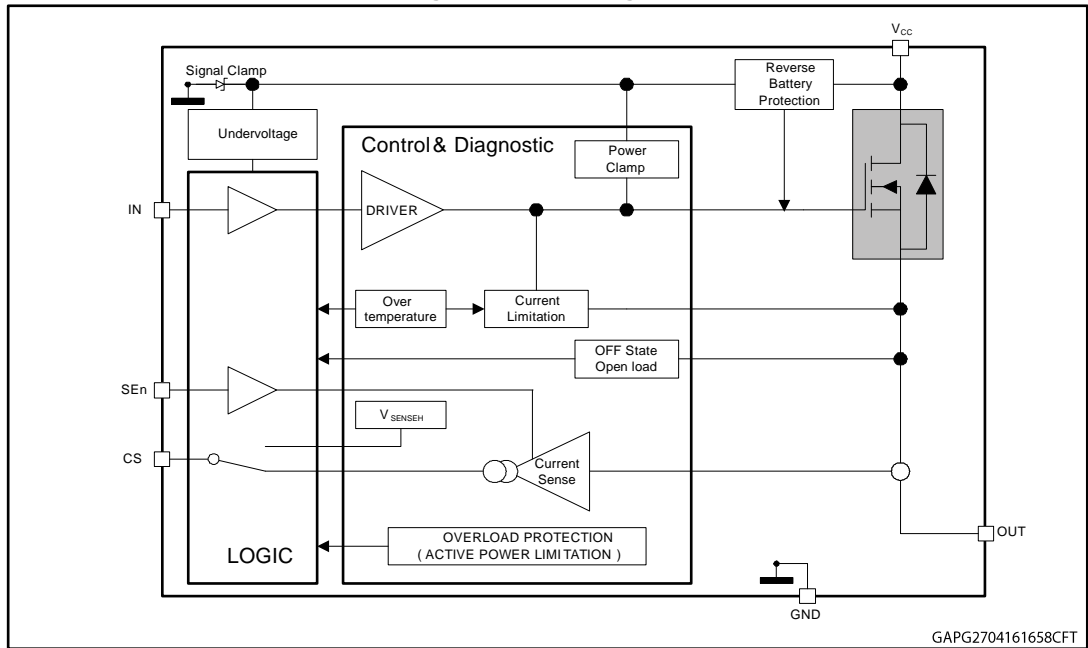

Table 2: Pin functions

Name	Function
V _{CC}	Battery connection.
OUTPUT	Power outputs. all the pins must be connected together.
GND	Ground connection.
INPUT	Voltage controlled input pin with hysteresis. Compatible with 3 V and 5 V CMOS outputs. It controls output switch state.
CS	Analog current sense output pin delivers a current proportional to the load current.
SEn	Active high compatible with 3 V and 5 V CMOS outputs pin; it enables the CurrentSense diagnostic pin.

Figure 2: Configuration diagram (top view)

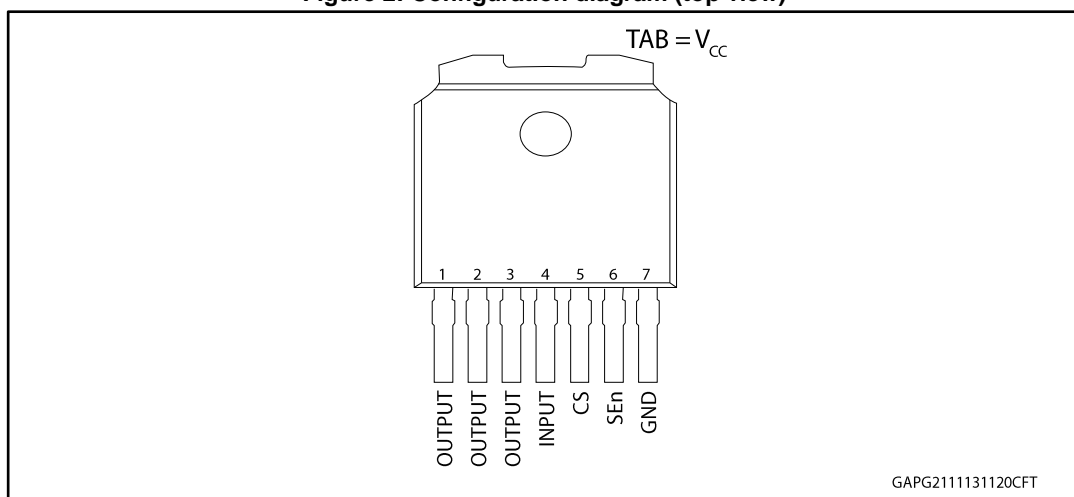

Table 3: Suggested connections for unused and not connected pins

Connection / pin	CurrentSense	N.C.	Output	Input	SEn
Floating	Not allowed	X ⁽¹⁾	X	X	X
To ground	Through 1 kΩ resistor	X	Not allowed	Through 15 kΩ resistor	Through 15 kΩ resistor

Notes:⁽¹⁾X: do not care.

2 Electrical specification

Figure 3: Current and voltage conventions



$V_F = V_{OUT} - V_{CC}$ when $V_{OUT} > V_{CC}$ and INPUT = LOW

2.1 Absolute maximum ratings

Stressing the device above the rating listed in [Table 4: "Absolute maximum ratings"](#) may cause permanent damage to the device. These are stress ratings only and operation of the device at these or any other conditions above those indicated in the operating sections of this specification is not implied. Exposure to the conditions in table below for extended periods may affect device reliability.

Table 4: Absolute maximum ratings

Symbol	Parameter	Value	Unit
V_{CC}	DC supply voltage	38	V
V_{CCPK}	Maximum transient supply voltage (ISO7637-2:2004 Pulse 5b level IV clamped to 40 V; $R_L = 4\Omega$)	40	
$-V_{CC}$	Reverse DC supply voltage	16	
$-I_{GND}$	DC reverse ground pin current	200	mA
I_{OUT}	OUTPUT DC output current	Internally limited	A
$-I_{OUT}$	Reverse DC output current	38	
I_{IN}	INPUT DC input current	-1 to 10	mA
I_{SEn}	SEn DC input current		
I_{SENSE}	CS pin DC output current ($V_{GND} = V_{CC}$ and $V_{SENSE} < 0$ V)	10	mA
	CS pin DC output current in reverse ($V_{CC} < 0$ V)	-20	
E_{MAX}	Maximum switching energy (single pulse) $T_{DEMAG} = 0.4$ ms; $T_{jstart} = 150^\circ\text{C}$	TBD	mJ

Symbol	Parameter	Value	Unit
V _{ESD}	Electrostatic discharge (JEDEC 22A-114F)		
	• INPUT	4000	V
	• CurrentSense	2000	V
	• SEn	4000	V
	• OUTPUT	4000	V
	• V _{CC}	4000	V
V _{ESD}	Charge device model (CDM-AEC-Q100-011)	750	V
T _j	Junction operating temperature	-40 to 150	°C
T _{stg}	Storage temperature	-55 to 150	

2.2 Thermal data

Table 5: Thermal data

Symbol	Parameter	Typ. value	Unit
R _{thj-board}	Thermal resistance junction-board ⁽¹⁾	2.1	°C/W
R _{thj-amb}	Thermal resistance junction-ambient (JEDEC JESD 51-5) ⁽²⁾	57.9	
R _{thj-amb}	Thermal resistance junction-ambient (JEDEC JESD 51-7) ⁽¹⁾	15.4	

Notes:

⁽¹⁾Device mounted on four-layers 2s2p PCB

⁽²⁾Device mounted on two-layers 2s0p PCB with 2 cm² heatsink copper trace

2.3 Electrical characteristics

7 V < V_{CC} < 28 V; -40°C < T_j < 150°C, unless otherwise specified.

All typical values refer to V_{CC} = 13 V; T_j = 25 °C, unless otherwise specified.

Table 6: Electrical characteristics during cranking

Symbol	Parameter	Test conditions	Min.	Typ.	Max.	Unit
V _{USD_Cranks}	Minimum cranking supply voltage (V _{CC} decreasing)			—	3	V
R _{ON}	On-state resistance	I _{OUT} = 4 A; V _{CC} = 3 V; V _{CC} decreasing		—	15	mΩ
T _{TSD} ⁽¹⁾	Shutdown temperature (V _{CC} decreasing)	V _{CC} = 3 V	140	—		°C

Notes:

⁽¹⁾Parameter guaranteed by design and characterization; not subject to production test.

Table 7: Power section

Symbol	Parameter	Test conditions	Min.	Typ.	Max.	Unit
V _{CC}	Operating supply voltage		4	13	28	V
V _{USD}	Undervoltage shutdown				3	V
V _{USDReset}	Undervoltage shutdown reset				5	V
V _{USDhyst}	Undervoltage shutdown hysteresis			0.3		V
R _{ON}	On-state resistance	I _{OUT} = 15 A; T _j = 25°C		3.5		mΩ
		I _{OUT} = 15 A; T _j = 150°C			7	
		I _{OUT} = 15 A; V _{CC} = 4 V; T _j = 25°C			5.25	
R _{ON_Rev}	R _{DSON} in reverse battery condition	V _{CC} = -13 V; I _{OUT} = -15 A; T _j = 25°C		3.5		mΩ
V _{clamp}	Clamp voltage	I _S = 20 mA; T _j = -40°C	38			V
		I _S = 20 mA; 25°C < T _j < 150°C	41	46	52	
I _{STBY}	Supply current in standby at V _{CC} = 13 V ⁽¹⁾	V _{CC} = 13 V; V _{IN} = V _{OUT} = V _{SEn} = 0 V; T _j = 25°C			0.5	μA
		V _{CC} = 13 V; V _{IN} = V _{OUT} = V _{SEn} = 0 V; T _j = 85°C ⁽²⁾			1.4	μA
		V _{CC} = 13 V; V _{IN} = V _{OUT} = V _{SEn} = 0 V; T _j = 125°C			11	μA
t _{D_STBY}	Standby mode blanking time	V _{CC} = 13 V; V _{IN} = 5 V; V _{SEn} = 0 V; I _{OUT} = 0 A	60	300	550	μs
I _{S(ON)}	Supply current	V _{CC} = 13 V; V _{SEn} = 0 V; V _{IN} = 5 V; I _{OUT} = 0 A		4	6.5	mA
I _{GND(ON)}	Control stage current consumption in ON-state. All channels active.	V _{CC} = 13 V; V _{SEn} = 5 V; V _{IN} = 5 V; I _{OUT} = 15 A			9	mA
I _{L(off)}	Off-state output current at V _{CC} = 13 V	V _{IN} = V _{OUT} = 0 V; V _{CC} = 13 V; T _j = 25°C	0	0.01	0.5	μA
		V _{IN} = V _{OUT} = 0 V; V _{CC} = 13 V; T _j = 125°C	0		11	
V _F	Output - V _{CC} diode voltage	I _{OUT} = -15 A; T _j = 150°C			0.7	V

Notes:

(1)PowerMOS leakage included.

(2)Parameter specified by design; not subject to production test.

Table 8: Switching

V _{CC} = 13 V; -40 °C < T _j < 150 °C, unless otherwise specified						
Symbol	Parameter	Test conditions	Min.	Typ.	Max.	Unit
t _{d(on)} ⁽¹⁾	Turn-on delay time at T _j = 25 °C	R _L = 0.87 Ω	10	50	120	μs
t _{d(off)} ⁽¹⁾	Turn-off delay time at T _j = 25 °C		10	60	100	
(dV _{OUT} /dt) _{on} ⁽¹⁾	Turn-on voltage slope at T _j = 25 °C	R _L = 0.87 Ω	0.075	0.28	0.7	V/μs
(dV _{OUT} /dt) _{off} ⁽¹⁾	Turn-off voltage slope at T _j = 25 °C		0.075	0.33	0.7	
W _{ON}	Switching energy losses at turn-on (t _{won})	R _L = 0.87 Ω	—	1.8	3.6 ⁽²⁾	mJ
W _{OFF}	Switching energy losses at turn-off (t _{woff})	R _L = 0.87 Ω	—	2	3.6 ⁽²⁾	mJ
t _{SKREW} ⁽¹⁾	Differential Pulse skew (t _{PHL} - t _{PLH})	R _L = 0.87 Ω	-50	0	50	μs

Notes:

⁽¹⁾See [Figure 6: "Switching times and Pulse skew"](#)

⁽²⁾Parameter guaranteed by design and characterization; not subject to production test.

Table 9: Logic inputs

7 V < V _{CC} < 28 V; -40 °C < T _j < 150 °C						
Symbol	Parameter	Test conditions	Min.	Typ.	Max.	Unit
INPUT characteristics						
V _{IL}	Input low level voltage				0.9	V
I _{IL}	Low level input current	V _{IN} = 0.9 V	1			μA
V _{IH}	Input high level voltage		2.1			V
I _{IH}	High level input current	V _{IN} = 2.1 V			10	μA
V _{I(hyst)}	Input hysteresis voltage		0.2			V
V _{ICL}	Input clamp voltage	I _{IN} = 1 mA	5.3		7.5	V
		I _{IN} = -1 mA		-0.7		
SEn characteristics (7 V < V_{CC} < 18 V)						
V _{SEnL}	Input low level voltage				0.9	V
I _{SEnL}	Low level input current	V _{IN} = 0.9 V	1			μA
V _{SEnH}	Input high level voltage		2.1			V
I _{SEnH}	High level input current	V _{IN} = 2.1 V			10	μA
V _{SEn(hyst)}	Input hysteresis voltage		0.2			V
V _{SEnCL}	Input clamp voltage	I _{IN} = 1 mA	5.3		7.5	V
		I _{IN} = -1 mA		-0.7		

Table 10: Protection

7 V < V _{CC} < 18 V; -40 °C < T _j < 150 °C						
Symbol	Parameter	Test conditions	Min.	Typ.	Max.	Unit
I _{LIMH} ⁽¹⁾	DC short circuit current	V _{CC} = 13 V	80	135	175	A
		4 V < V _{CC} < 18 V ⁽²⁾			175	
I _{LIML}	Short circuit current during thermal cycling	V _{CC} = 13 V; T _R < T _j < T _{TSD}		38		
T _{TSD}	Shutdown temperature		150	175	200	°C
T _R	Reset temperature ⁽²⁾		T _{RS} + 1	T _{RS} + 7		°C
T _{RS}	Thermal reset of fault diagnostic indication	V _{SEn} = 5 V	135			°C
T _{HYST}	Thermal hysteresis (T _{TSD} - T _R) ⁽²⁾			7		°C
ΔT _{J,SD}	Dynamic temperature	V _{CC} = 13 V		60		K
V _{DEMAG}	Turn-off output voltage clamp	I _{OUT} = 2 A; L = 6 mH; T _j = -40°C	V _{CC} - 38			V
		I _{OUT} = 2 A; L = 6 mH; T _j = 25°C to 150°C	V _{CC} - 41	V _{CC} - 46	V _{CC} - 52	V

Notes:

(1)Parameter guaranteed by an indirect test sequence.

(2)Parameter guaranteed by design and characterization; not subject to production test.

Table 11: CurrentSense

7 V < V _{CC} < 18 V; -40 °C < T _j < 150 °C						
Symbol	Parameter	Test conditions	Min.	Typ.	Max.	Unit
V _{SENSE_CL}	CurrentSense clamp voltage	V _{SEn} = 0 V; I _{SENSE} = 1 mA	-17		-12	V
		V _{SEn} = 0 V; I _{SENSE} = -1 mA		7		V
Current Sense characteristics						
K _{OL} ⁽¹⁾	I _{OUT} /I _{SENSE}	I _{OUT} = 200 mA; V _{SENSE} = 0.5 V; V _{SEn} = 5 V	8350	16800	25150	
K ₀	I _{OUT} /I _{SENSE}	I _{OUT} = 1 A; V _{SENSE} = 0.5 V; V _{SEn} = 5 V	9000	16650	24500	
dK ₀ /K ₀ ⁽²⁾⁽³⁾	Current sense ratio drift	I _{OUT} = 1 A; V _{SENSE} = 0.5 V; V _{SEn} = 5 V	-30		30	%
K ₁	I _{OUT} /I _{SENSE}	I _{OUT} = 10 A; V _{SENSE} = 4 V; V _{SEn} = 5 V	13150	16450	19750	
dK ₁ /K ₁ ⁽²⁾⁽³⁾	Current sense ratio drift	I _{OUT} = 10 A; V _{SENSE} = 4 V; V _{SEn} = 5 V	-10		10	%
K ₂	I _{OUT} /I _{SENSE}	I _{OUT} = 15 A; V _{SENSE} = 4 V; V _{SEn} = 5 V	14200	16450	19100	
dK ₂ /K ₂ ⁽²⁾⁽³⁾	Current sense ratio drift	I _{OUT} = 15 A; V _{SENSE} = 4 V; V _{SEn} = 5 V	-7		7	%

7 V < V _{CC} < 18 V; -40 °C < T _j < 150 °C						
Symbol	Parameter	Test conditions	Min.	Typ.	Max.	Unit
K ₃	I _{OUT} /I _{SENSE}	I _{OUT} = 45 A; V _{SENSE} = 4 V; V _{SEn} = 5 V	14760	16450	18670	
dK ₃ /K ₃ ⁽²⁾⁽³⁾	Current sense ratio drift	I _{OUT} = 45 A; V _{SENSE} = 4 V; V _{SEn} = 5 V	-5		5	%
I _{SENSE0}	CurrentSense leakage current	CurrentSense disabled: V _{SEn} = 0 V;	0		0.5	μA
		CurrentSense disabled; -1 V < V _{SENSE} < 5 V ⁽³⁾	-0.5		0.5	μA
		CurrentSense enabled: V _{SEn} = 5 V; V _{IN} = 5 V; I _{OUT} = 0 A;	0		5	μA
V _{OUT_CSD} ⁽³⁾	Output voltage for CurrentSense shutdown	V _{SEn} = 5 V; R _{SENSE} = 2.7 kΩ; V _{IN} = 5 V; I _{OUT} = 15 A		5		V
V _{SENSE_SAT}	CurrentSense saturation voltage	V _{CC} = 7 V; R _{SENSE} = 10 kΩ; V _{SEn} = 5 V; V _{IN} = 5 V; I _{OUT} = 15 A; T _j = -40°C	5			V
I _{SENSE_SAT} ⁽³⁾	CS saturation current	V _{CC} = 7 V; V _{SENSE} = 4 V; V _{IN} = 5 V; V _{SEn} = 5 V; T _j = -40°C	4			mA
I _{OUT_SAT} ⁽³⁾	Output saturation current	V _{CC} = 7 V; V _{SENSE} = 4 V; V _{IN} = 5 V; V _{SEn} = 5 V; T _j = -40°C	75			A
OFF-state diagnostic						
V _{OL}	OFF-state open-load voltage detection threshold	V _{IN} = 0 V; V _{SEn} = 5 V;	2	3	4	V
I _{L(off2)}	OFF-state output sink current	V _{IN} = 0 V; V _{OUT} = V _{OL} ; T _j = -40°C to 125°C	-100		-15	μA
t _{DSTKON}	OFF-state diagnostic delay time from falling edge of INPUT (see Figure 7: "tDSTKON")	V _{IN} = 5 V to 0 V; V _{SEn} = 5 V; I _{OUT} = 0 A; V _{OUT} = 4 V	100	350	700	μs
t _{D_OL_V}	Settling time for valid OFF-state open load diagnostic indication from rising edge of SE _n	V _{IN} = 0 V; V _{OUT} = 4 V; V _{SEn} = 0 V to 5 V			60	μs
t _{D_VOL}	OFF-state diagnostic delay time from rising edge of V _{OUT}	V _{IN} = 0 V; V _{SEn} = 5 V; V _{OUT} = 0 V to 4 V		5	30	μs
Fault diagnostic feedback (see Table 12: "Truth table")						
V _{SENSEH}	CurrentSense output voltage in fault condition	V _{CC} = 13 V; V _{IN} = 0 V; V _{SEn} = 5 V; I _{OUT} = 0 A; V _{OUT} = 4 V; R _{SENSE} = 1 kΩ	5		6.6	V
I _{SENSEH}	CurrentSense output current in fault condition	V _{CC} = 13 V; V _{SENSE} = 5 V	7	20	30	mA

7 V < V _{CC} < 18 V; -40 °C < T _j < 150 °C						
Symbol	Parameter	Test conditions	Min.	Typ.	Max.	Unit
CurrentSense timings (current sense mode)⁽⁴⁾						
t _{DSENSE1H}	Current sense settling time from rising edge of SEn	V _{IN} = 5 V; V _{SEn} = 0 V to 5 V; R _{SENSE} = 1 kΩ; R _L = 0.87 Ω			60	μs
t _{DSENSE1L}	Current sense disable delay time from falling edge of SEn	V _{IN} = 5 V; V _{SEn} = 5 V to 0 V; R _{SENSE} = 1 kΩ; R _L = 0.87 Ω		5	20	μs
t _{DSENSE2H}	Current sense settling time from rising edge of INPUT	V _{IN} = 0 V to 5 V; V _{SEn} = 5 V; R _{SENSE} = 1 kΩ; R _L = 0.87 Ω		100	380	μs
Δt _{DSENSE2H}	Current sense settling time from rising edge of I _{OUT} (dynamic response to a step change of I _{OUT})	V _{IN} = 5 V; V _{SEn} = 5 V; R _{SENSE} = 1 kΩ; I _{SENSE} = 90% of I _{SENSEMAX} ; R _L = 0.87 Ω			200	μs
t _{DSENSE2L}	Current sense turn-off delay time from falling edge of INPUT	V _{IN} = 5 V to 0 V; V _{SEn} = 5 V; R _{SENSE} = 1 kΩ; R _L = 0.87 Ω		50	250	μs

Notes:

- (1) Digital filtering is applied for testing
- (2) All values refer to V_{CC} = 13 V; T_j = 25°C, unless otherwise specified.
- (3) Parameter guaranteed by design and characterization; not subject to production test.
- (4) Transition delay are measured up to ±10% of final conditions.

Figure 4: I_{OUT}/I_{SENSE} versus I_{OUT}

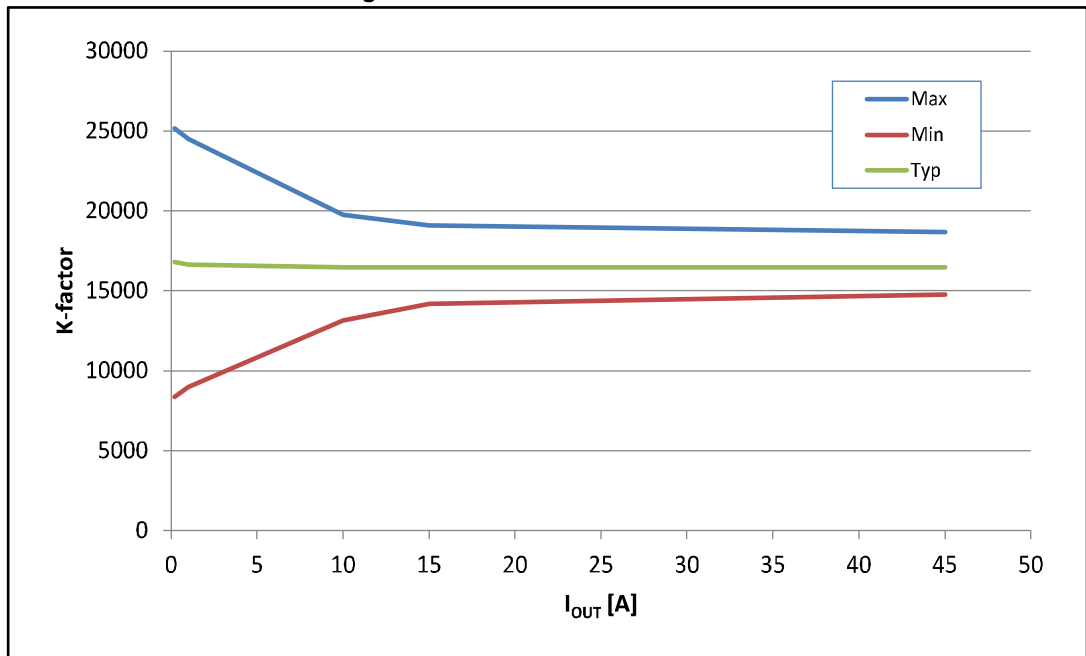

Figure 5: Current sense precision vs. IOU

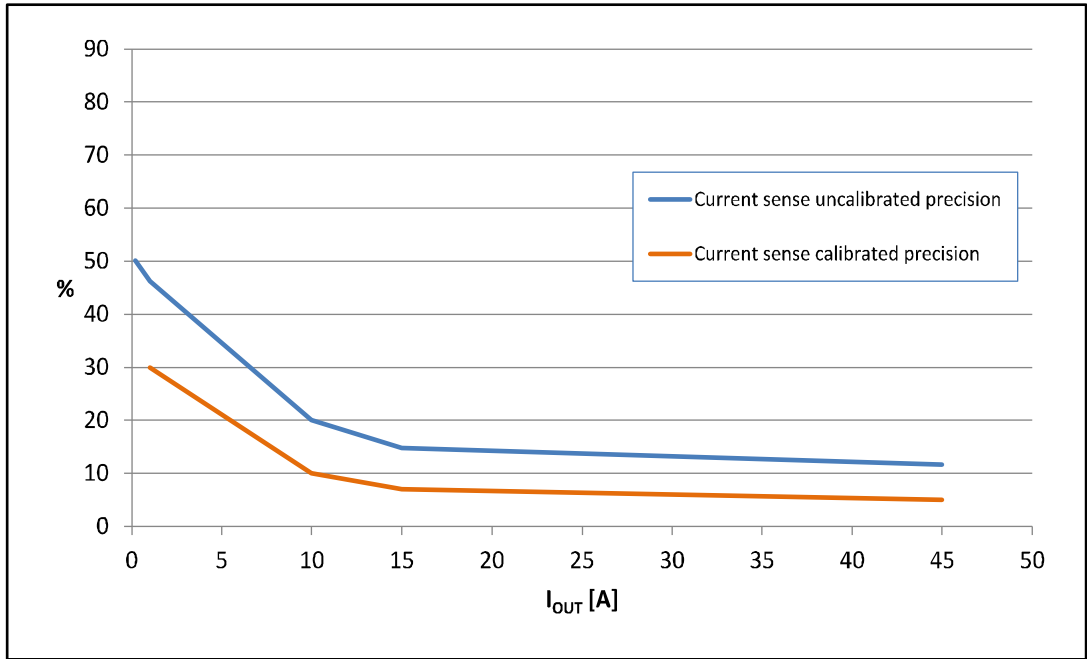

Figure 6: Switching times and Pulse skew

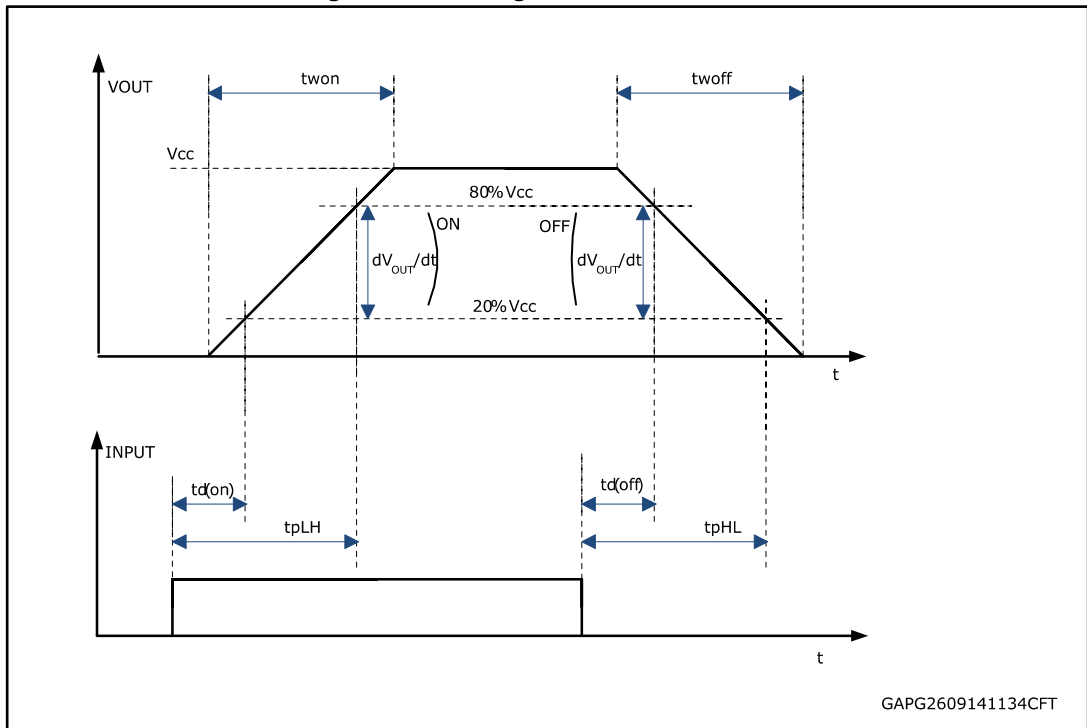

Figure 7: tDSTKON

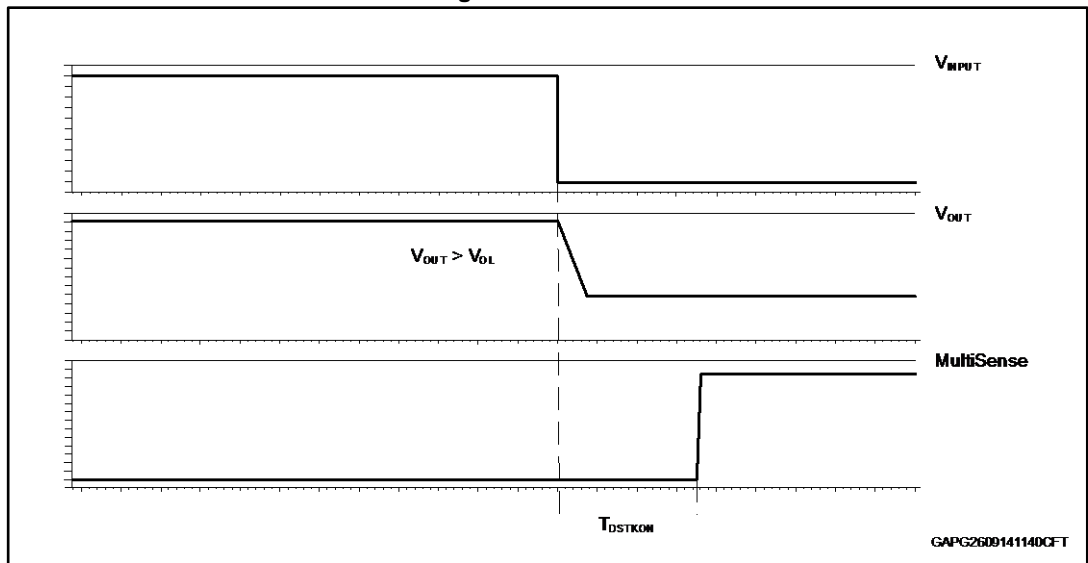

Table 12: Truth table

Mode	Conditions	IN _x	SEn	OUT _x	Current Sense	Comments
Stand by	All logic inputs low	L	L	L	Hi-Z	Low quiescent current consumption
Normal	Nominal load connected; T _j < 150°C	L	H	L	0	
		H	L	H	Hi-Z	
		H	H	H	I _{SENSE} = 1/K * I _{OUT}	
Overload	Overload or short to GND causing: T _j > T _{TSD} or ΔT _j > ΔT _{j,SD}	H	L	H	Hi-Z	Output cycles with temperature hysteresis
		H	H	H	V _{SENSEH}	
Under-voltage	V _{CC} < V _{USD} (falling)	X	X	L L	Hi-Z Hi-Z	Re-start when V _{CC} > V _{USD} + V _{USDhyst} (rising)
OFF-state diagnostics	Short to V _{CC}	L	H	H	V _{SENSEH}	
	Open-load	L	H	H		External pull-up
Negative output voltage	Inductive loads turn-off	L	X	< 0 V	0	

2.4 Electrical characteristics curves

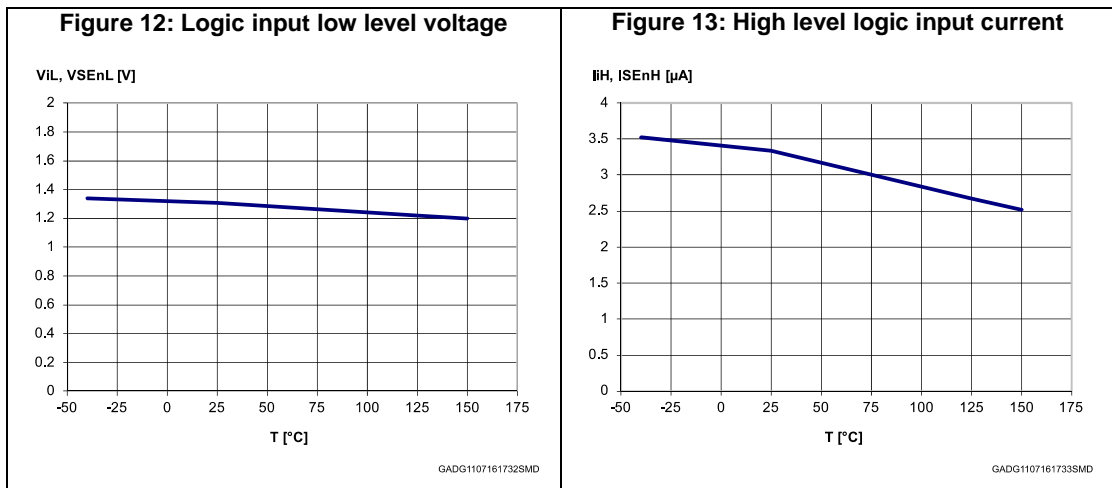
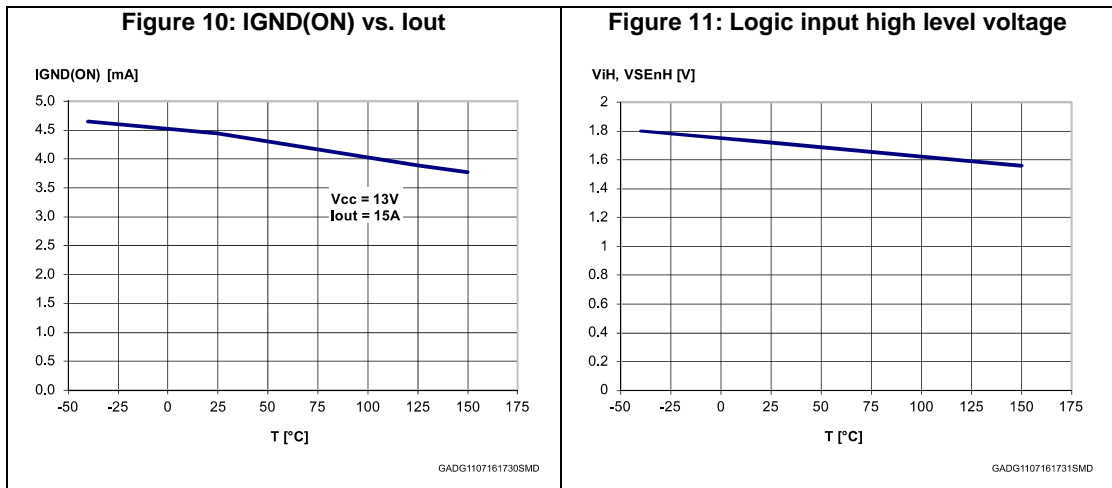
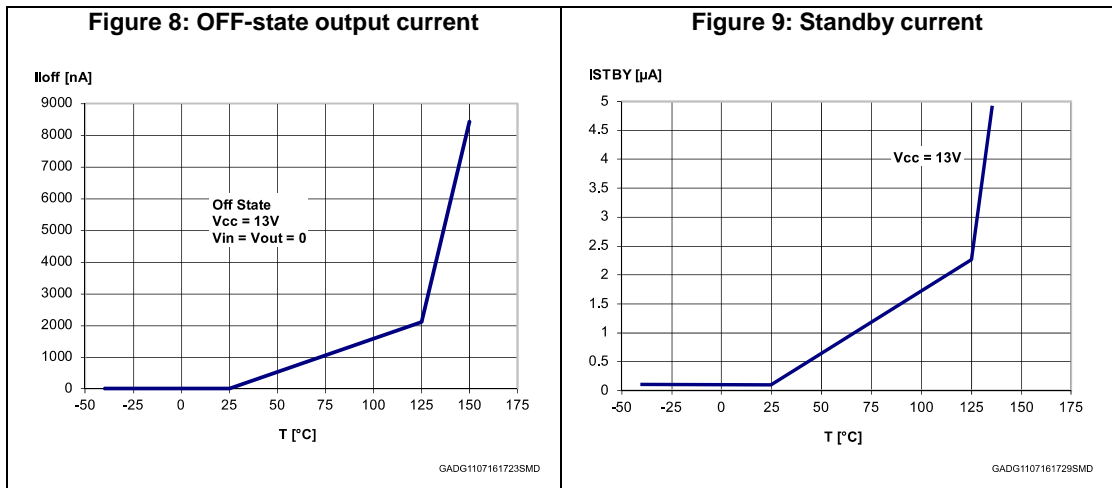
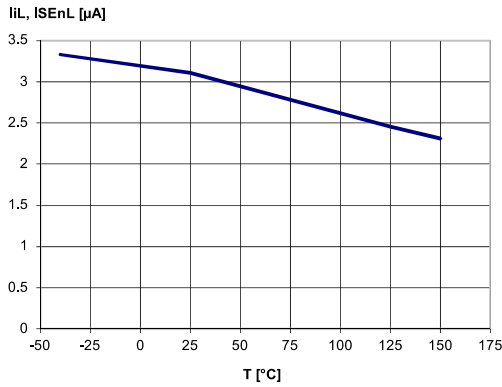
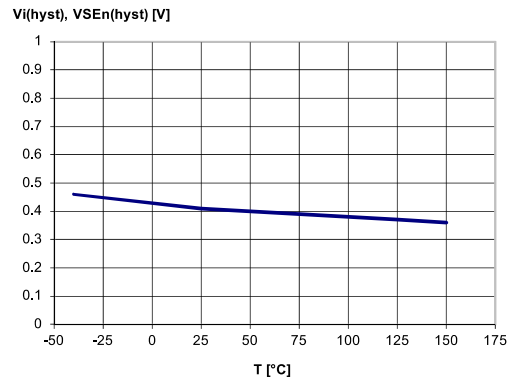

Figure 14: Low level logic input current



GADG1107161734SMD

Figure 15: Logic input hysteresis voltage



GADG1107161735SMD

Figure 16: Undervoltage shutdown

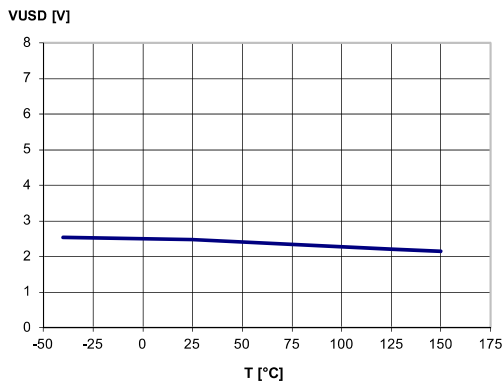

GADG1107161736SMD

Figure 17: On-state resistance vs. Tcase

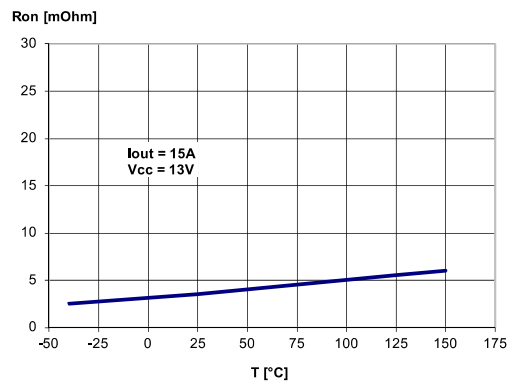

GADG1107161737SMD

Figure 18: On-state resistance vs. VCC

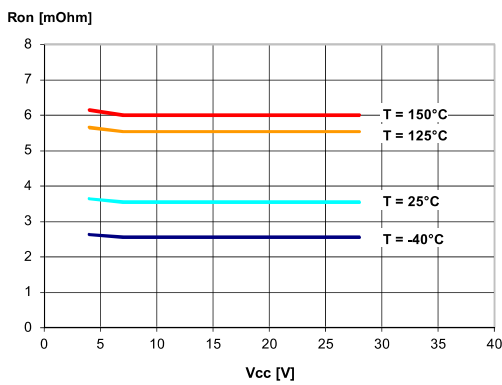

GADG1107161738SMD

Figure 19: Turn-on voltage slope

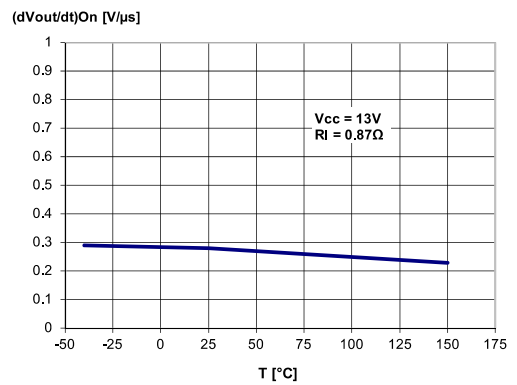

GADG1107161739SMD

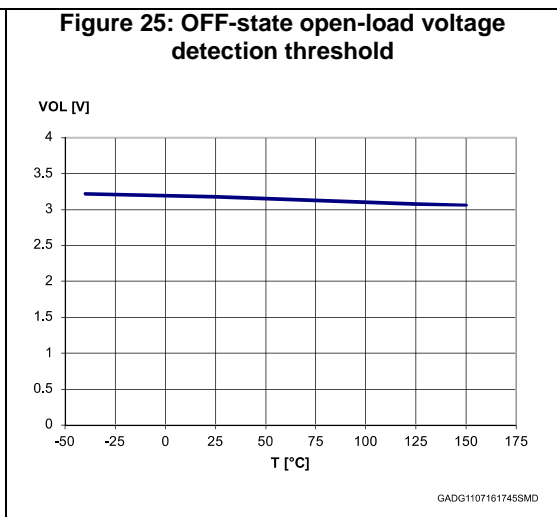
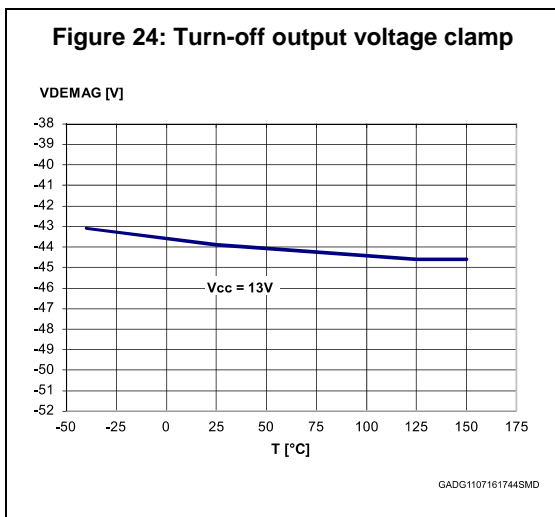
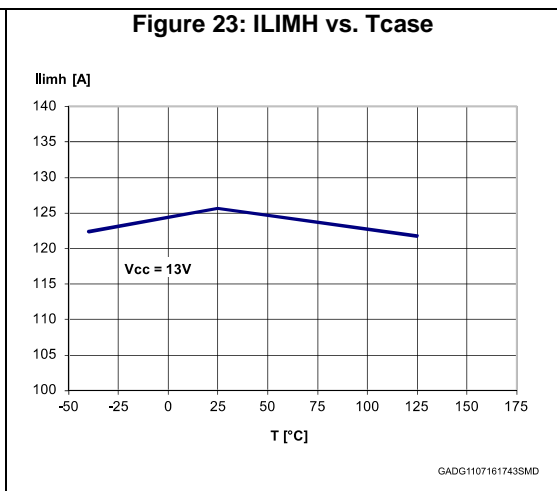
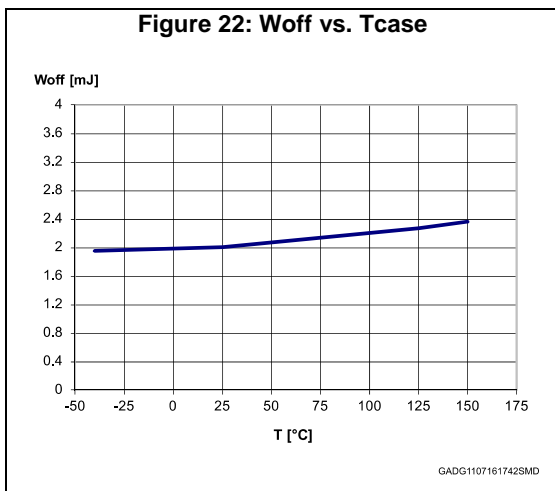
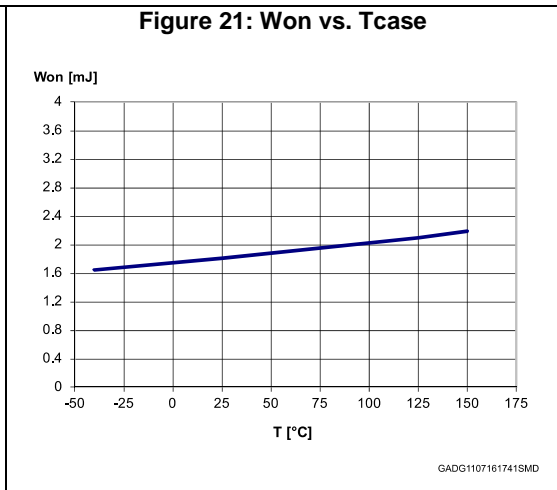
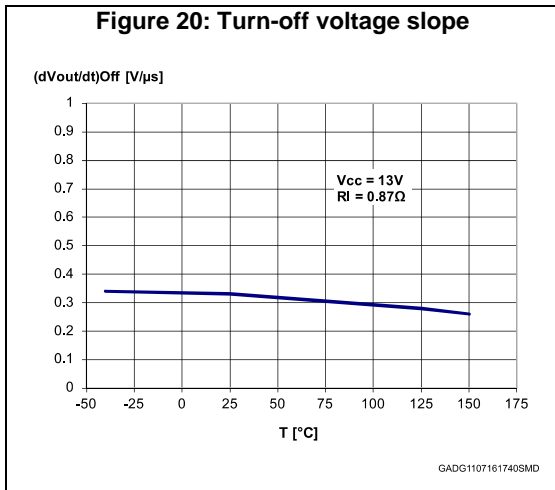
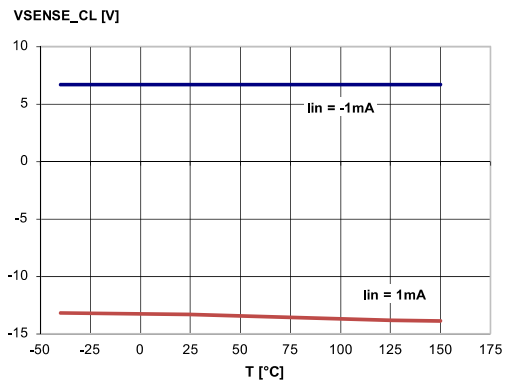
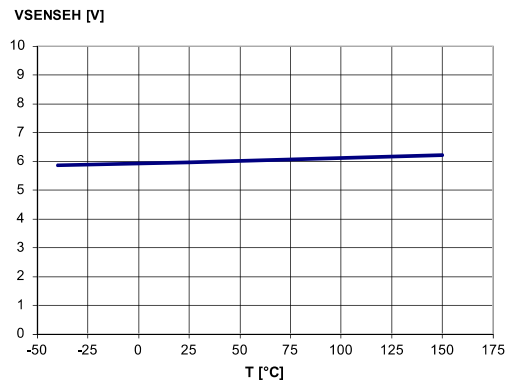

Figure 26: Vs clamp vs. Tcase



GADG1107161746SMD

Figure 27: Vsenseh vs. Tcase



GADG1107161747SMD

3 Protections

3.1 Power limitation

The basic working principle of this protection consists of an indirect measurement of the junction temperature swing ΔT_j through the direct measurement of the spatial temperature gradient on the device surface in order to automatically shut off the output MOSFET as soon as ΔT_j exceeds the safety level of ΔT_{j_SD} . The protection prevents fast thermal transient effects and, consequently, reduces thermo-mechanical fatigue.

3.2 Thermal shutdown

In case the junction temperature of the device exceeds the maximum allowed threshold (typically 175°C), it automatically switches off and the diagnostic indication is triggered. The device switches on again as soon as its junction temperature drops to T_R .

3.3 Current limitation

The device is equipped with an output current limiter in order to protect the silicon as well as the other components of the system (e.g. bonding wires, wiring harness, connectors, loads, etc.) from excessive current flow. Consequently, in case of short circuit, overload or during load power-up, the output current is clamped to a safety level, I_{LIMH} , by operating the output power MOSFET in the active region.

3.4 Negative voltage clamp

In case the device drives inductive load, the output voltage reaches negative value during turn off. A negative voltage clamp structure limits the maximum negative voltage to a certain value, V_{DEMAG} , allowing the inductor energy to be dissipated without damaging the device.

4 Application information

Figure 28: Application diagram

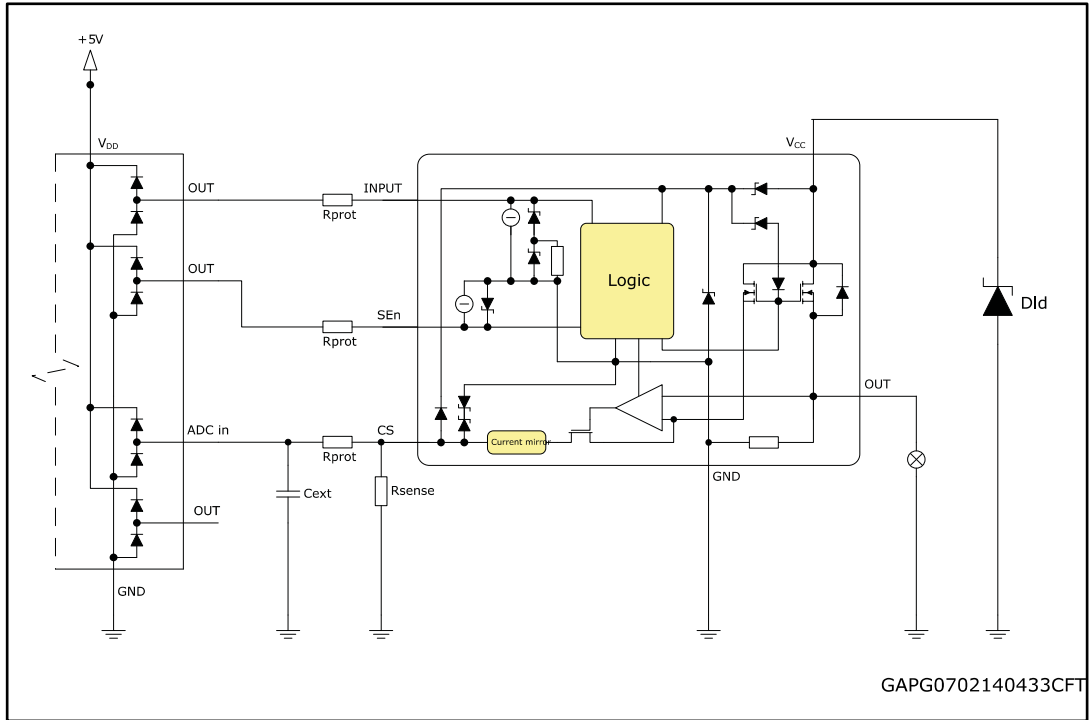

4.1 Protection against reverse battery

Figure 29: Simplified internal structure

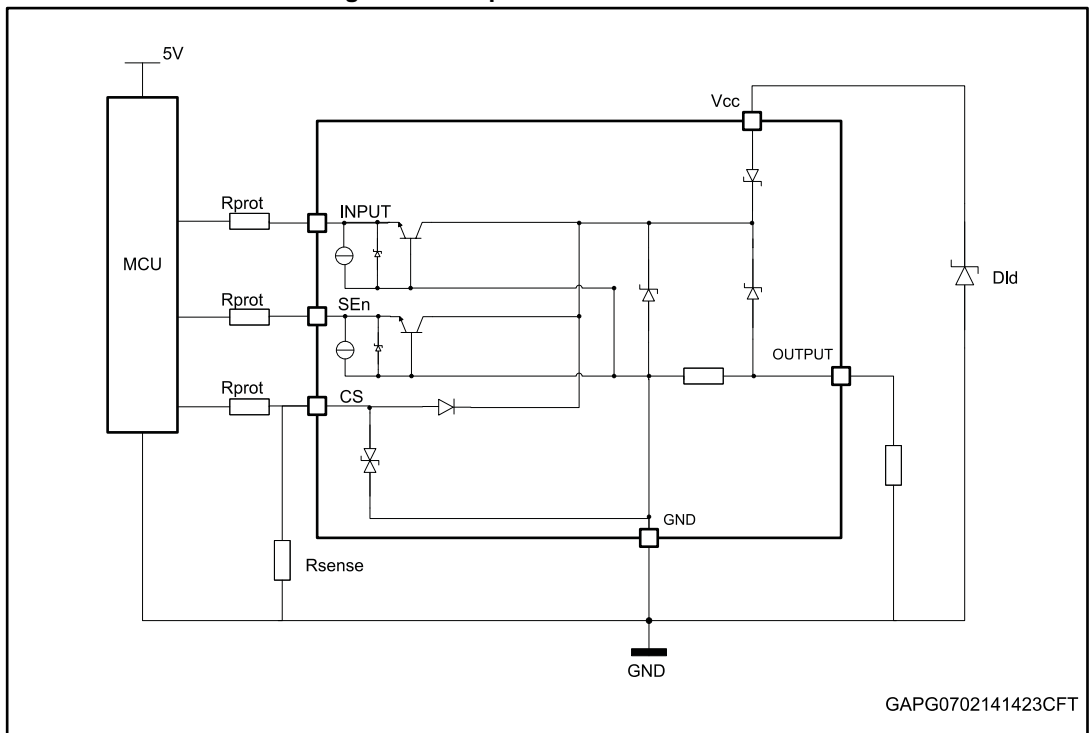

The device does not need any external components to protect the internal logic in case of a reverse battery condition. The protection is provided by internal structures.

In addition, due to the fact that the output MOSFET turns on even in reverse battery mode, thus providing the same low ohmic path as in regular operating conditions, no additional power dissipation has to be considered.

4.2 Immunity against transient electrical disturbances

The immunity of the device against transient electrical emissions, conducted along the supply lines and injected into the V_{CC} pin, is tested in accordance with ISO7637-2:2011 (E) and ISO 16750-2:2010.

The related function performance status classification is shown in [Table 13: "ISO 7637-2 - electrical transient conduction along supply line"](#).

Test pulses are applied directly to DUT (Device Under Test) both in ON and OFF-state and in accordance to ISO 7637-2:2011(E), chapter 4. The DUT is intended as the present device only, without components and accessed through V_{CC} and GND terminals.

Status II is defined in ISO 7637-1 Function Performance Status Classification (FPSC) as follows: "The function does not perform as designed during the test but returns automatically to normal operation after the test".

Table 13: ISO 7637-2 - electrical transient conduction along supply line

Test Pulse 2011(E)	Test pulse severity level with Status II functional performance status		Minimum number of pulses or test time	Burst cycle / pulse repetition time		Pulse duration and pulse generator internal impedance
	Level	$U_s^{(1)}$		min	max	
1	III	-112V	500 pulses	0,5 s		2ms, 10 Ω
2a	III	+55V	500 pulses	0,2 s	5 s	50 μ s, 2 Ω
3a	IV	-220V	1h	90 ms	100 ms	0.1 μ s, 50 Ω
3b	IV	+150V	1h	90 ms	100 ms	0.1 μ s, 50 Ω
4 ⁽²⁾	IV	-7V	1 pulse			100ms, 0.01 Ω
Load dump according to ISO 16750-2:2010						
Test B ⁽³⁾		40V	5 pulse	1 min		400ms, 2 Ω

Notes:

⁽¹⁾ U_s is the peak amplitude as defined for each test pulse in ISO 7637-2:2011(E), chapter 5.6.

⁽²⁾Test pulse from ISO 7637-2:2004(E).

⁽³⁾With 40 V external suppressor referred to ground ($-40^{\circ}\text{C} < T_j < 150^{\circ}\text{C}$).

4.3 MCU I/Os protection

If a ground protection network is used and negative transients are present on the V_{CC} line, the control pins will be pulled negative. ST suggests to insert a resistor (R_{prot}) in line both to prevent the microcontroller I/O pins from latch-up and to protect the HSD inputs.

The value of these resistors is a compromise between the leakage current of microcontroller and the current required by the HSD I/Os (Input levels compatibility) with the latch-up limit of microcontroller I/Os.

Equation

$$V_{CCpeak}/I_{latchup} \leq R_{prot} \leq (V_{OH\mu C} - V_{IH} - V_{GND}) / I_{IHmax}$$

Calculation example:

For $V_{CCpeak} = -150\text{ V}$; $I_{latchup} \geq 20\text{ mA}$; $V_{OH\mu C} \geq 4.5\text{ V}$

$7.5\text{ k}\Omega \leq R_{prot} \leq 140\text{ k}\Omega$.

Recommended values: $R_{prot} = 15\text{ k}\Omega$

4.4 CS - analog current sense

Diagnostic information on device and load status are provided by an analog output pin (CS) delivering the following signal:

- Current monitor: current monitor of channel output current

Figure 30: CurrentSense and diagnostic – block diagram

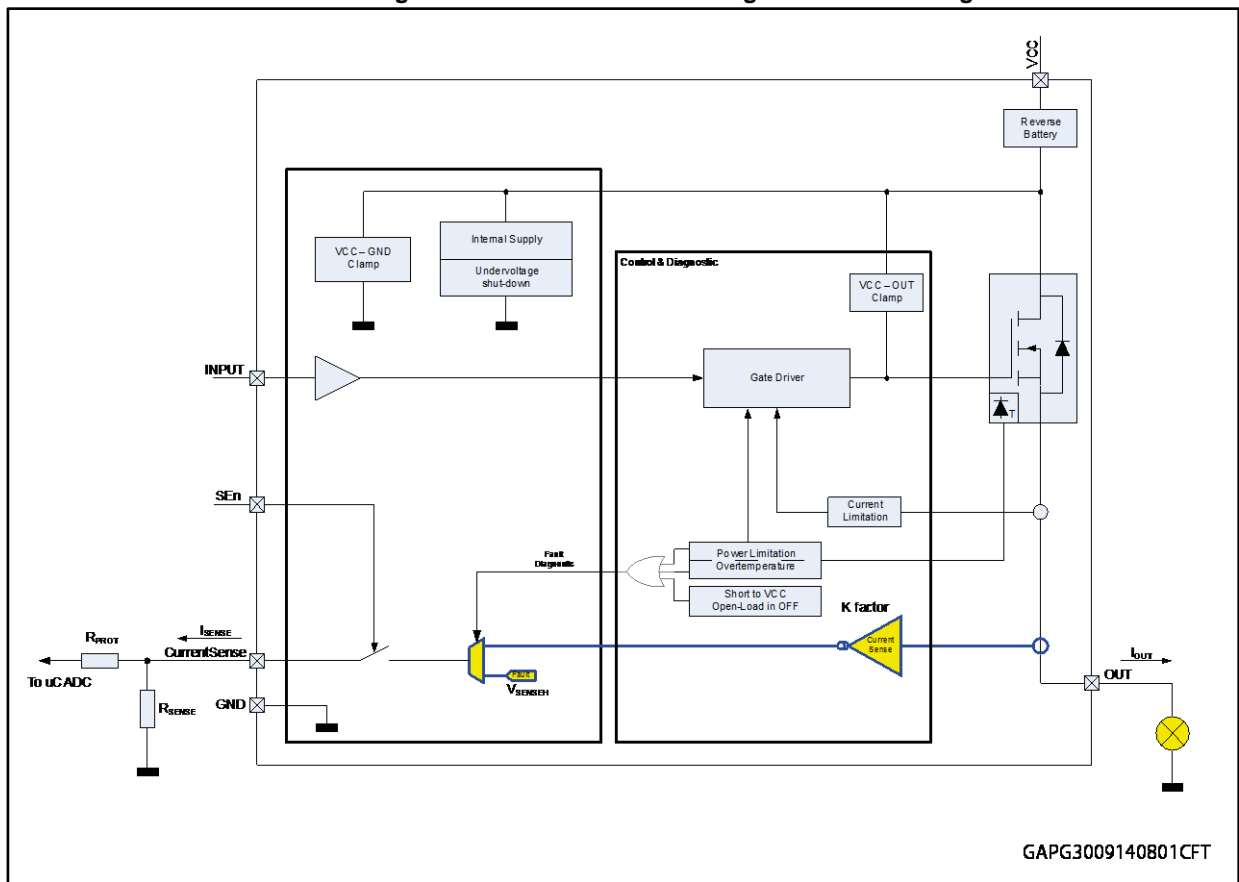

4.4.1 Principle of CurrentSense signal generation

Figure 31: CurrentSense block diagram

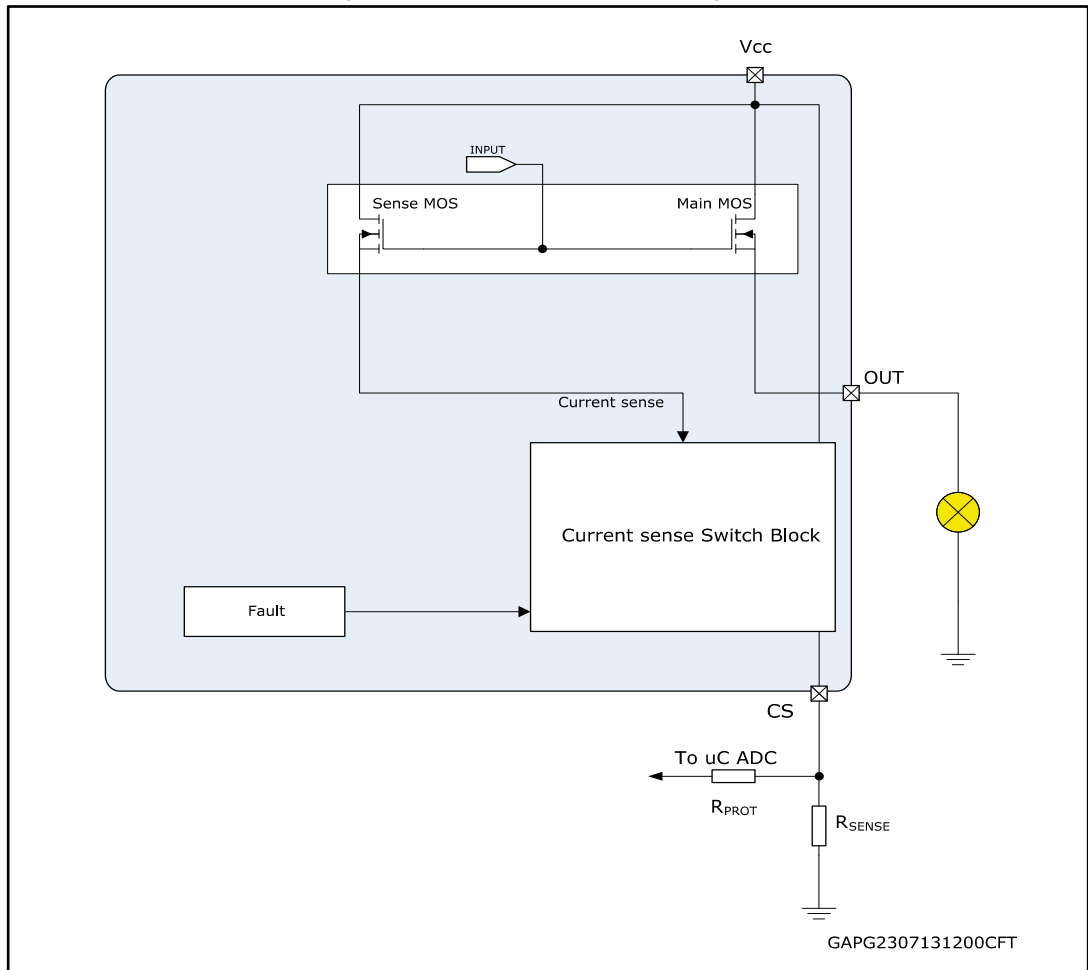

Current sense

This output is capable of providing:

- Current mirror proportional to the load current in normal operation, delivering current proportional to the load according to known ratio named K
- Diagnostics flag in fault conditions delivering fixed voltage V_{SENSEH}

The current delivered by the current sense circuit, I_{SENSE} , can be easily converted to a voltage V_{SENSE} by using an external sense resistor, R_{SENSE} , allowing continuous load monitoring and abnormal condition detection.

Normal operation (channel ON, no fault, SEn active)

While device is operating in normal conditions (no fault intervention), V_{SENSE} calculation can be done using simple equations

Current provided by CurrentSense output: $I_{SENSE} = I_{OUT}/K$

Voltage on R_{SENSE} : $V_{SENSE} = R_{SENSE} * I_{SENSE} = R_{SENSE} * I_{OUT}/K$

Where :

- V_{SENSE} is voltage measurable on R_{SENSE} resistor
- I_{SENSE} is current provided from CS pin in current output mode
- I_{OUT} is current flowing through output
- K factor represents the ratio between PowerMOS cells and SenseMOS cells; its spread includes geometric factor spread, current sense amplifier offset and process parameters spread of overall circuitry specifying ratio between I_{OUT} and I_{SENSE} .

Failure flag indication

In case of power limitation/overtemperature, the fault is indicated by the CS pin which is switched to a “current limited” voltage source, V_{SENSEH} .

In any case, the current sourced by the CS in this condition is limited to I_{SENSEH}

Figure 32: Analogue HSD – open-load detection in off-state

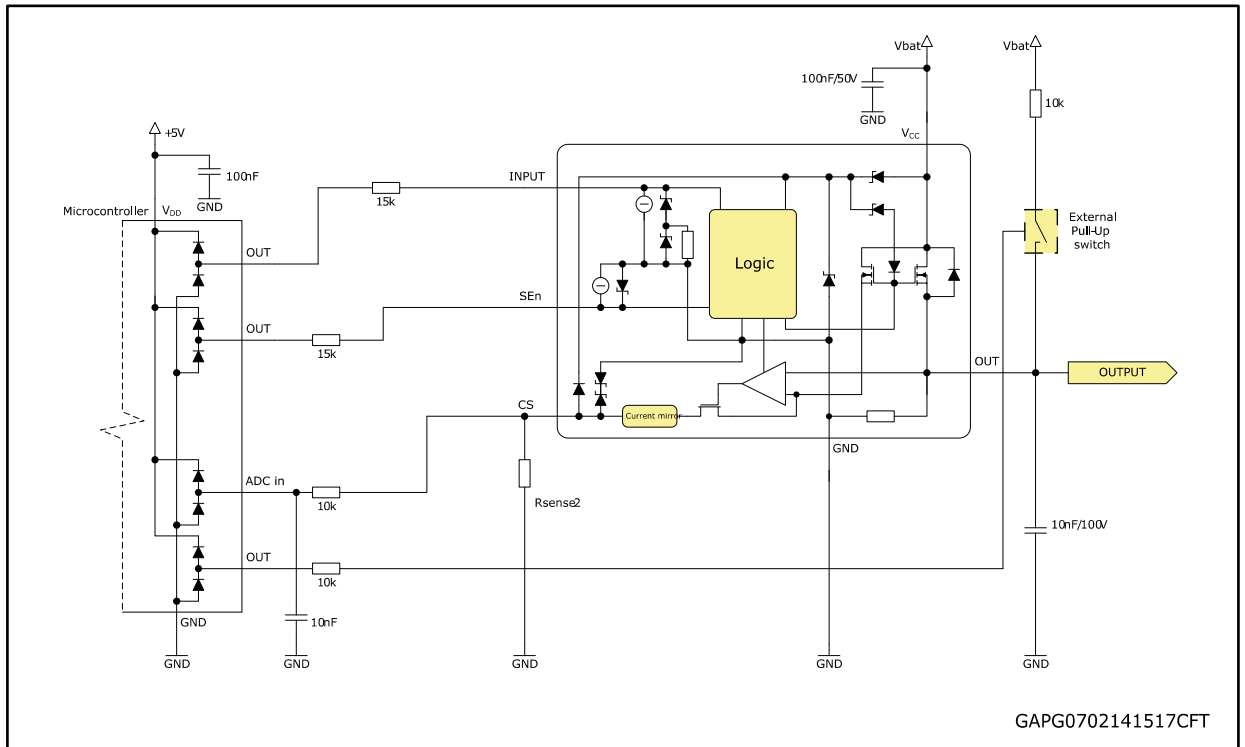
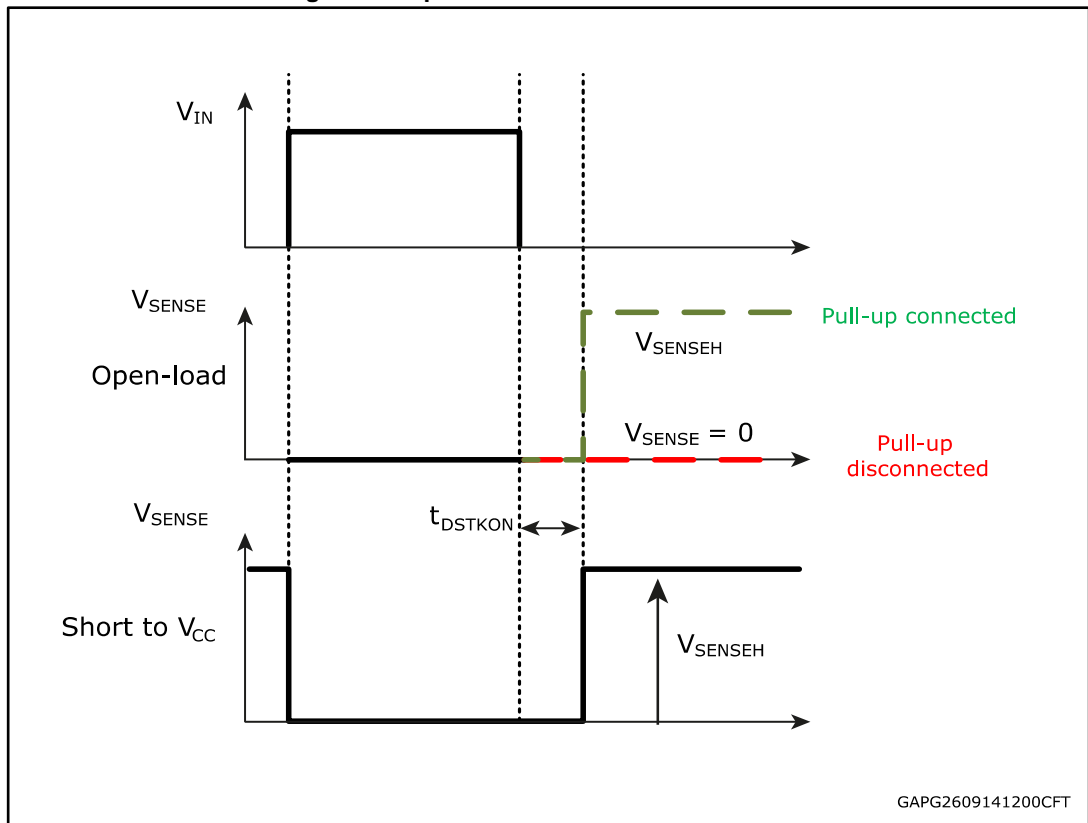

Figure 33: Open-load / short to VCC condition



GAPG2609141200CFT

Table 14: CurrentSense pin levels in off-state

Condition	Output	CurrentSense	SEn
Open-load	$V_{OUT} > V_{OL}$	Hi-Z	L
		V_{SENSEH}	H
	$V_{OUT} < V_{OL}$	Hi-Z	L
		0	H
Short to V_{CC}	$V_{OUT} > V_{OL}$	Hi-Z	L
		V_{SENSEH}	H
Nominal	$V_{OUT} < V_{OL}$	Hi-Z	L
		0	H

4.4.2 Short to VCC and OFF-state open-load detection

Short to V_{CC}

A short circuit between V_{CC} and output is indicated by the relevant current sense pin set to V_{SENSEH} during the device off-state. Small or no current is delivered by the current sense during the on-state depending on the nature of the short circuit.

OFF-state open-load with external circuitry

Detection of an open-load in off mode requires an external pull-up resistor R_{PU} connecting the output to a positive supply voltage V_{PU} .

It is preferable V_{PU} to be switched off during the module standby mode in order to avoid the overall standby current consumption to increase in normal conditions, i.e. when load is connected.

R_{PU} must be selected in order to ensure $V_{OUT} > V_{OLmax}$ in accordance with the following equation:

Equation

$$R_{PU} < \frac{V_{PU} - 4}{I_{L(off2)min @ 4V}}$$

5 Maximum demagnetization energy (VCC = 16 V)

Figure 34: Maximum turn off current versus inductance

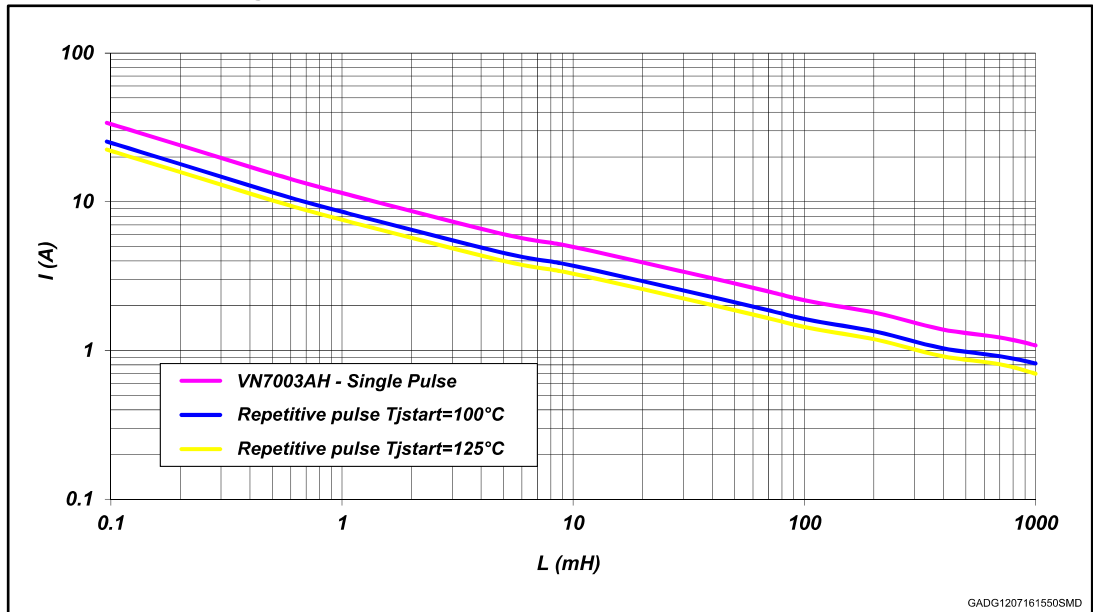

6 Package and PCB thermal data

6.1 Octapak thermal data

Figure 35: Octapak on two-layers PCB (2s0p to JEDEC JESD 51-5)

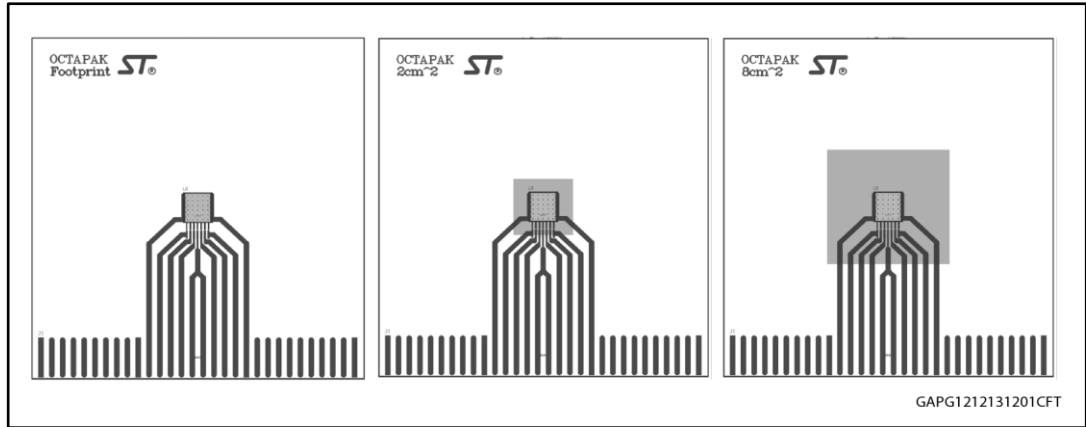

Figure 36: Octapak on four-layers PCB (2s2p to JEDEC JESD 51-7)

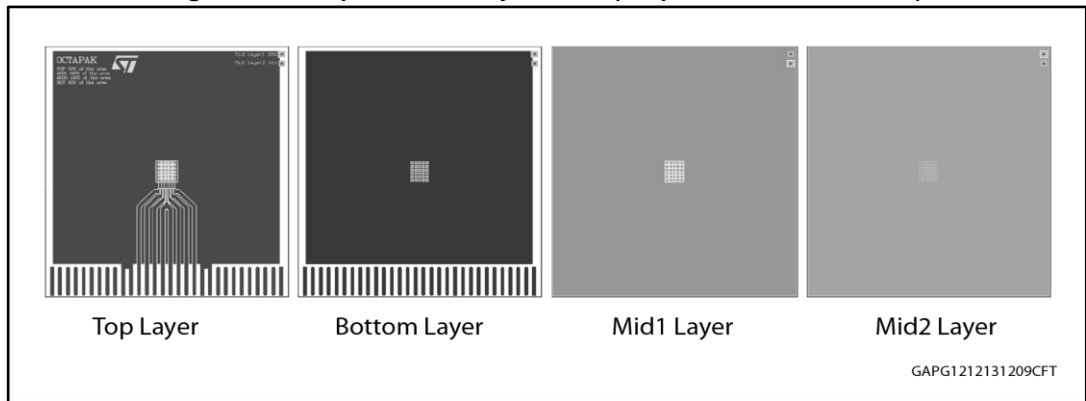

Table 15: PCB properties

Dimension	Value
Board finish thickness	1.6 mm +/- 10%
Board dimension	77 mm x 86 mm
Board Material	FR4
Copper thickness (top and bottom layers)	0.070 mm
Copper thickness (inner layers)	0.035 mm
Thermal vias separation	1.2 mm
Thermal via diameter	0.3 mm +/- 0.08 mm
Copper thickness on vias	0.025 mm
Footprint dimension (top layer)	6.4 mm x 7mm
Heatsink copper area dimension (bottom layer)	Footprint, 2 cm ² or 8 cm ²

Figure 37: Rthj-amb vs PCB copper area in open box free air conditions

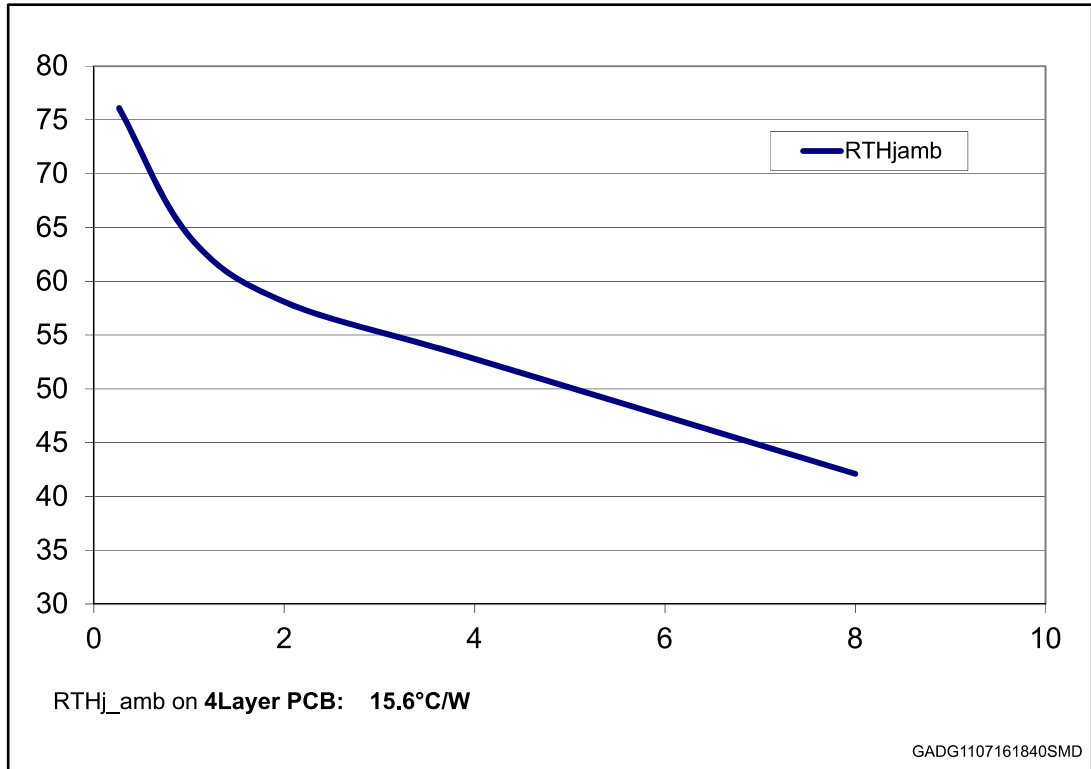
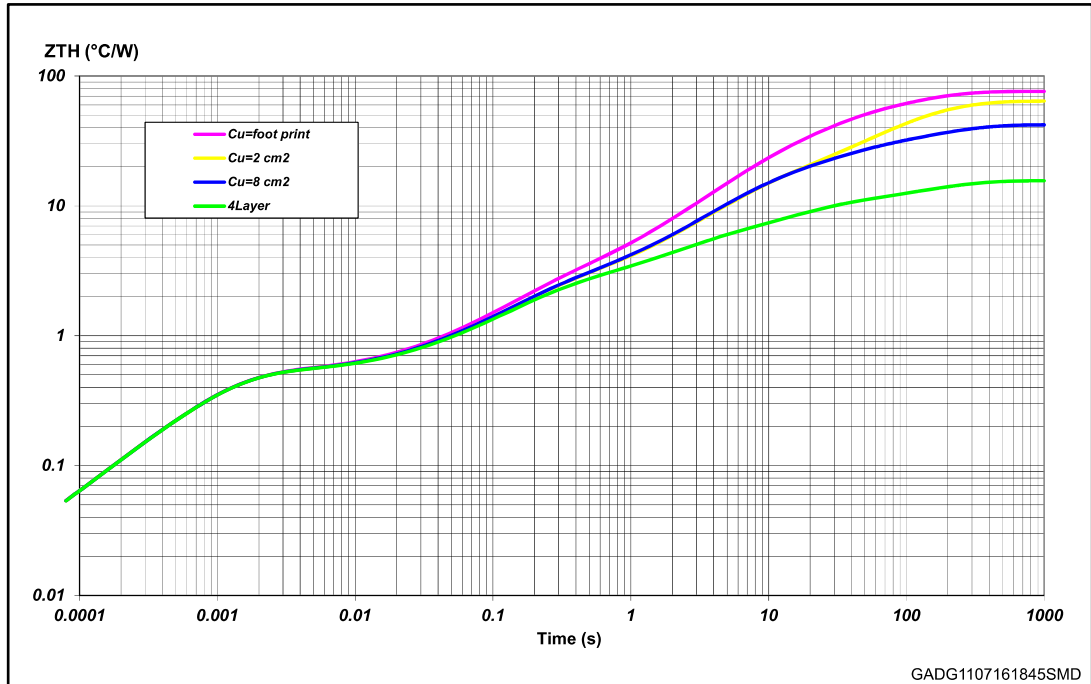

Figure 38: Octapak thermal impedance junction ambient single pulse



Equation: Pulse calculation formula

$$Z_{TH\delta} = R_{TH} + Z_{THtp} (1 - \delta)$$

where $\delta = t_p/T$

Figure 39: Thermal fitting model for Octapak

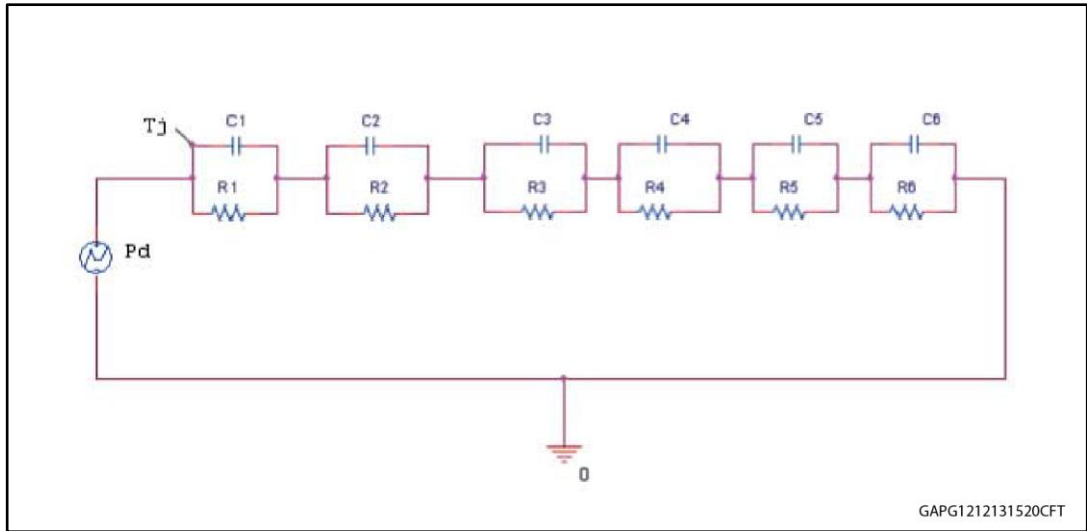

The fitting model is a simplified thermal tool and is valid for transient evolutions where the embedded protections (power limitation or thermal cycling during thermal shutdown) are not triggered.

Table 16: Thermal parameters

Area/island (cm ²)	Footprint	2	8	4L
R1 (°C/W)	0.01	0.01	0.01	0.01
R2 (°C/W)	0.5	0.5	0.5	0.5
R3 (°C/W)	1.6	1.6	1.6	1.6
R4 (°C/W)	10	10	10	2.5
R5 (°C/W)	28	20	12	5
R6 (°C/W)	36	26	18	6
C1 (W.s/°C)	0.001	0.001	0.001	0.001
C2 (W.s/°C)	0.0018	0.0018	0.0018	0.0018
C3 (W.s/°C)	0.11	0.11	0.11	0.11
C4 (W.s/°C)	0.6	0.6	0.6	0.8
C5 (W.s/°C)	0.8	1.4	2.2	3
C6 (W.s/°C)	3	6	9	25

7 Package information

In order to meet environmental requirements, ST offers these devices in different grades of ECOPACK® packages, depending on their level of environmental compliance. ECOPACK® specifications, grade definitions and product status are available at: www.st.com. ECOPACK® is an ST trademark.

7.1 Octapak package information

Figure 40: Octapak package dimensions

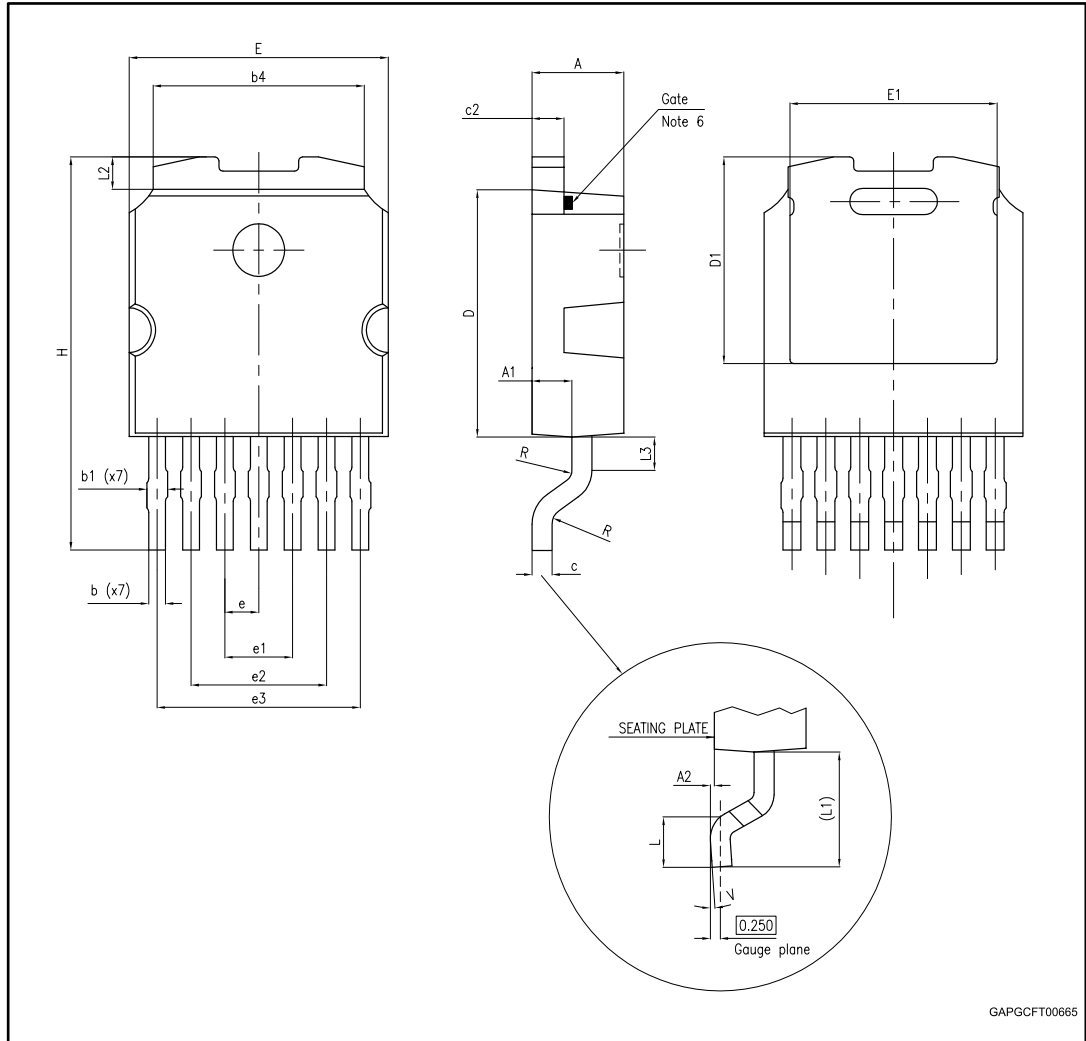

GAPGCF00665

Table 17: Octapak mechanical data

Symbol	Millimeters		
	Min.	Typ.	Max.
A	2.20	2.30	2.40
A1	0.90	1.00	1.10
A2	0.03		0.15
b	0.38	0.45	0.52

Symbol	Millimeters		
	Min.	Typ.	Max.
b1			0.70
b4	5.20	5.30	5.40
c	0.45	0.50	0.60
c2	0.75	0.80	0.90
D	6.00	6.10	6.20
D1		5.15	
E	6.40	6.50	6.60
E1		5.30	
e	0.85 BSC		
e1	1.60	1.70	1.80
e2	3.30	3.40	3.50
e3	5.00	5.10	5.20
H	9.35	9.70	10.10
L	1.00		—
(L1)		2.80	
L2		0.80	
L3		0.85	
R	0.40 BSC		
V2	0°		8°

7.2 Octapak packing information

Figure 41: Octapak reel 13"

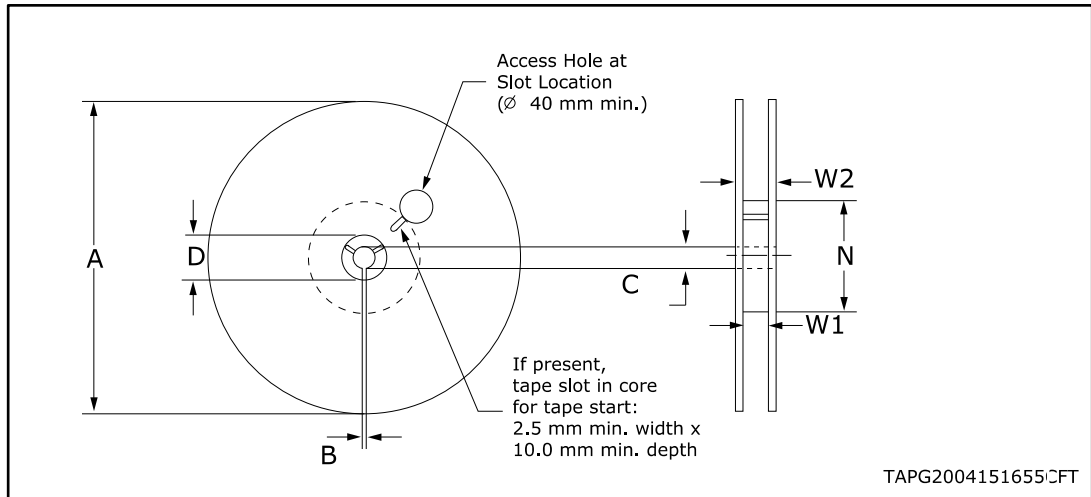

Table 18: Reel dimensions

Description	Value ⁽¹⁾
Base quantity	2500
Bulk quantity	2500
A (max)	330
B (min)	1.5
C (+0.5, -0.2)	13
D	20.2
N	100
W1 (+2 /-0)	16.4
W2 (max)	22.4

Notes:

(1)All dimensions are in mm.

Figure 42: Octapak carrier tape

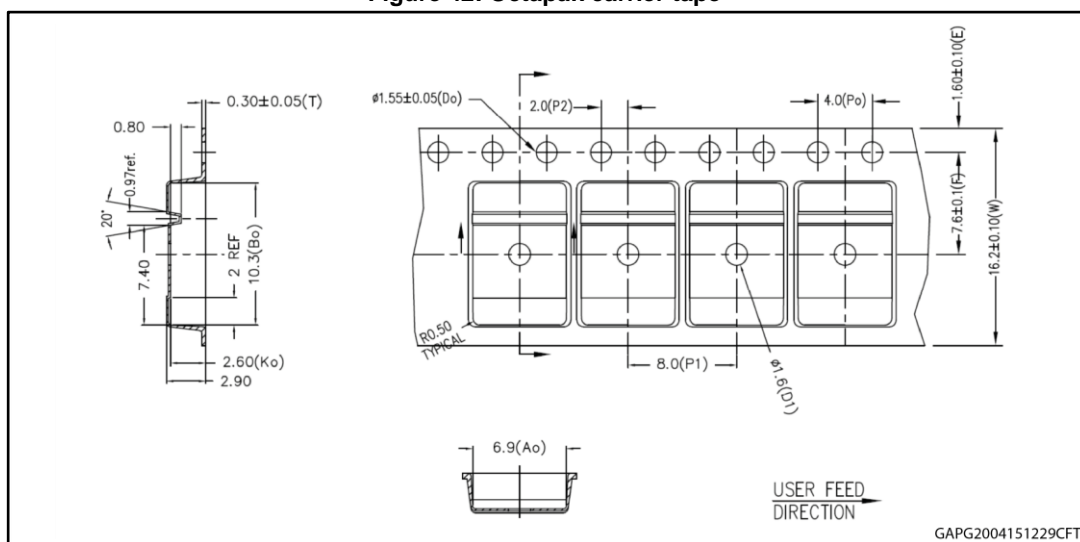

GAPG2004151229CFT

Figure 43: Octapak schematic drawing of leader and trailer tape

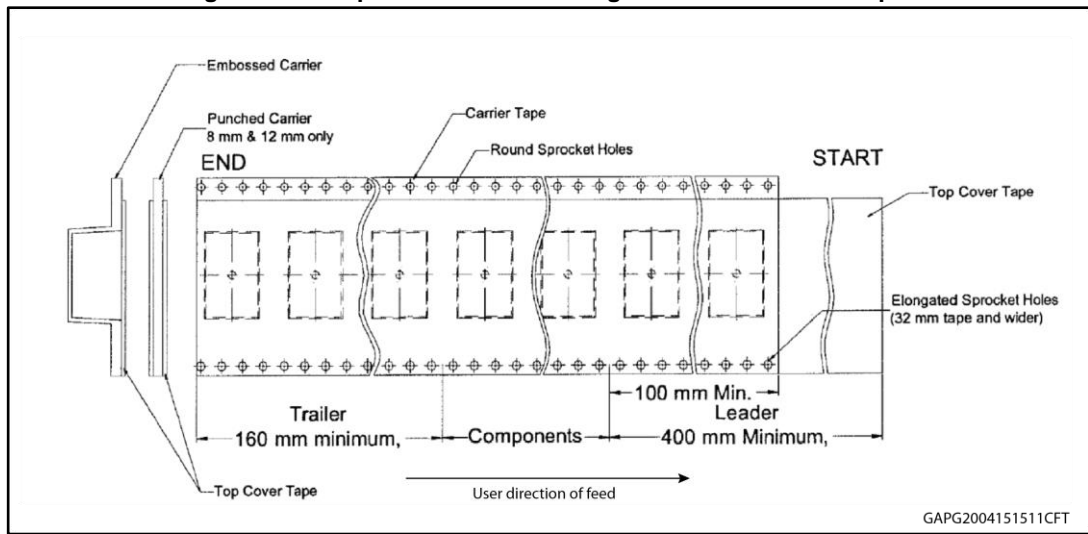

7.3 Octapak marking information

Figure 44: Octapak marking information

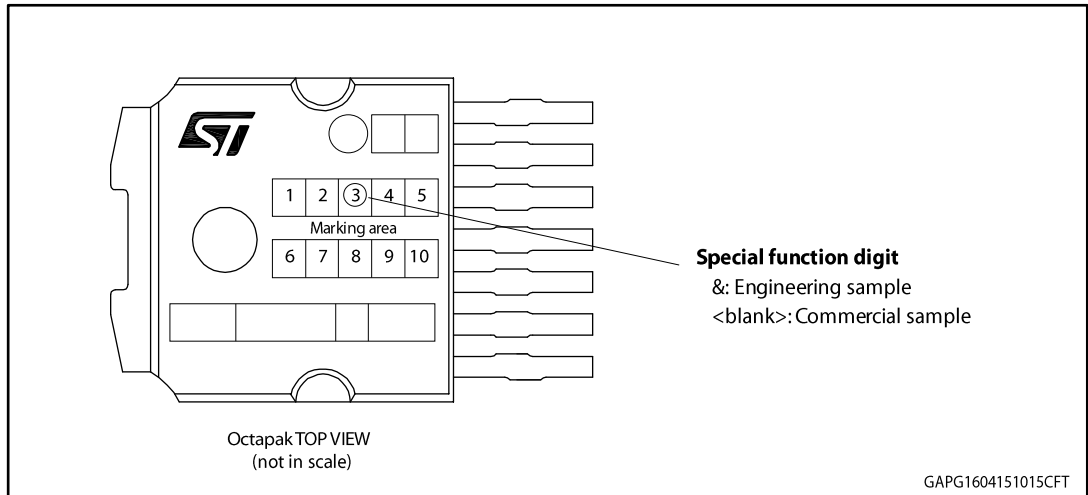

Parts marked as "&" are not yet qualified and therefore not yet ready to be used in production and any consequences deriving from such usage will not be at ST charge. In no event, ST will be liable for any customer usage of these engineering samples in production. ST Quality has to be contacted prior to any decision to use these Engineering Samples to run qualification activity.

8 Revision history

Table 19: Document revision history

Date	Revision	Changes
15-Apr-2016	1	Initial release
02-Aug-2016	2	<p>Doc status upgraded to production data</p> <p><i>Section "Features"</i></p> <ul style="list-style-type: none"> added AEC-Q100 qualification I_{LIMH}: updated current limitation feature <p><i>Figure 1: "Block diagram"</i></p> <ul style="list-style-type: none"> updated figure <p><i>Table 4: "Absolute maximum ratings"</i></p> <ul style="list-style-type: none"> E_{MAX}: updated value and the T_{DEMAG} <p><i>Table 5: "Thermal data"</i></p> <ul style="list-style-type: none"> R_{thj-board} changed to R_{thj-case} All typ. values updated <p><i>Table 8: "Switching"</i></p> <ul style="list-style-type: none"> updated Min., Typ. and Max. columns <p><i>Table 10: "Protection"</i></p> <ul style="list-style-type: none"> I_{LIMH}: updated Typ. and Max. values I_{LIML}: updated Typ. value ΔT_{J_SD}: removed temperature condition <p><i>Table 11: "CurrentSense"</i></p> <ul style="list-style-type: none"> K_{OL}: added Typ. value V_{SENSE_SAT}, I_{SENSE_SAT} and I_{OUT_SAT}: updated test conditions CurrentSense timings (current sense mode): updated test condition R_L t_{DSENSE2H}: updated Max. value <p>Added <i>Figure 4: "IOUT/ISENSE versus IOUT"</i></p> <p>Added <i>Figure 5: "Current sense precision vs. IOUT"</i></p> <p>Added <i>Section 2.4: "Electrical characteristics curves"</i></p> <p>Added <i>Figure 34: "Maximum turn off current versus inductance"</i></p> <p>Updated <i>Section 7.1: "Octapak package information"</i></p>
03-Aug-2016	3	Restored <i>Figure 28: "Application diagram"</i> and <i>Figure 32: "Analogue HSD – open-load detection in off-state"</i> , inadvertently altered in document revision 2.
02-Nov-2016	4	Updated Applications section

IMPORTANT NOTICE – PLEASE READ CAREFULLY

STMicroelectronics NV and its subsidiaries ("ST") reserve the right to make changes, corrections, enhancements, modifications, and improvements to ST products and/or to this document at any time without notice. Purchasers should obtain the latest relevant information on ST products before placing orders. ST products are sold pursuant to ST's terms and conditions of sale in place at the time of order acknowledgement.

Purchasers are solely responsible for the choice, selection, and use of ST products and ST assumes no liability for application assistance or the design of Purchasers' products.

No license, express or implied, to any intellectual property right is granted by ST herein.

Resale of ST products with provisions different from the information set forth herein shall void any warranty granted by ST for such product.

ST and the ST logo are trademarks of ST. All other product or service names are the property of their respective owners.

Information in this document supersedes and replaces information previously supplied in any prior versions of this document.

© 2016 STMicroelectronics – All rights reserved

Компания «Life Electronics» занимается поставками электронных компонентов импортного и отечественного производства от производителей и со складов крупных дистрибьюторов Европы, Америки и Азии.

С конца 2013 года компания активно расширяет линейку поставок компонентов по направлению коаксиальный кабель, кварцевые генераторы и конденсаторы (керамические, пленочные, электролитические), за счёт заключения дистрибьюторских договоров

Мы предлагаем:

- Конкурентоспособные цены и скидки постоянным клиентам.
- Специальные условия для постоянных клиентов.
- Подбор аналогов.
- Поставку компонентов в любых объемах, удовлетворяющих вашим потребностям.
- Приемлемые сроки поставки, возможна ускоренная поставка.
- Доставку товара в любую точку России и стран СНГ.
- Комплексную поставку.
- Работу по проектам и поставку образцов.
- Формирование склада под заказчика.
- Сертификаты соответствия на поставляемую продукцию (по желанию клиента).
- Тестирование поставляемой продукции.
- Поставку компонентов, требующих военную и космическую приемку.
- Входной контроль качества.
- Наличие сертификата ISO.

В составе нашей компании организован Конструкторский отдел, призванный помогать разработчикам, и инженерам.

Конструкторский отдел помогает осуществить:

- Регистрацию проекта у производителя компонентов.
- Техническую поддержку проекта.
- Защиту от снятия компонента с производства.
- Оценку стоимости проекта по компонентам.
- Изготовление тестовой платы монтаж и пусконаладочные работы.



Тел: +7 (812) 336 43 04 (многоканальный)
Email: org@lifeelectronics.ru