



MAX9918 Evaluation Kit

General Description

The MAX9918 evaluation kit (EV kit) provides a proven design to evaluate the MAX9918 wide input range, precision unidirectional/bidirectional, current-sense amplifier in an 8-pin SO package. The EV kit features Kelvin connections for force and sense at the amplifier inputs and a very precise current-sense resistor with a tolerance of $\pm 0.5\%$. Various test points are included for additional evaluation.

The MAX9918 EV kit PCB comes with a MAX9918ASA+ installed. Contact the factory for free samples of the pin-compatible MAX9919FASA+, MAX9919NASA+, and MAX9920ASA+ to evaluate these devices.

Features

- ◆ Wide -20V to +75V Input Range Independent of Supply Voltage
- ◆ Operates Off a Single +5V Supply
- ◆ Unidirectional or Bidirectional Operation
- ◆ Lead(Pb)-Free and RoHS Compliant
- ◆ Proven PCB Layout
- ◆ Fully Assembled and Tested

Ordering Information

PART	TYPE
MAX9918EVKIT+	EV Kit

+Denotes lead(Pb)-free and RoHS compliant.

Component List

DESIGNATION	QTY	DESCRIPTION
C1	1	0.1 μ F $\pm 10\%$, 16V X7R ceramic capacitor (0603) TDK C1608X7R1C104K
C2	1	10 μ F $\pm 20\%$, 6.3V X5R ceramic capacitor (0805) TDK C2012X5R0J106M
JU1	1	3-pin header
JU2	1	2-pin header
P1, P2	2	Binding posts
R1	1	1k Ω $\pm 0.1\%$ resistor (0805)

DESIGNATION	QTY	DESCRIPTION
R2	1	88.7k Ω $\pm 0.1\%$ resistor (0805)
R3	1	0.05 Ω $\pm 0.5\%$, 0.5W 4-terminal current-sense resistor (1206) Ohmite LVK12R050DER
TP1-TP5	5	Red test points
U1	1	Precision bidirectional current-sense amplifier (8 SO) Maxim MAX9918ASA+
—	2	Shunts
—	1	PCB: MAX9918 Evaluation Kit+

Component Supplier

SUPPLIER	PHONE	WEBSITE
TDK Corp.	847-803-6100	www.component.tdk.com

Note: Indicate that you are using the MAX9918 when contacting this component supplier.

Evaluates: MAX9918/MAX9919/MAX9920

MAX9918 Evaluation Kit

Quick Start

Required Equipment

- MAX9918 EV kit
- +5V, 10mA DC power supply
- +14V, 1A DC power supply
- Electronic load or equivalent resistor load
- Two digital voltmeters (DVM1, DVM2)

Procedure

The MAX9918 EV kit is fully assembled and tested. Follow the steps below to verify board operation:

- 1) Verify that the jumpers are in their default position, as shown in Table 1.
- 2) Connect the positive terminal of the +5V supply to VCC and the negative terminal to GND.
- 3) Connect the positive terminal of the +14V supply to P1. Connect P2 into the positive terminal of an electronic load. Connect the negative terminal of the electronic load to the GND terminal on the +14V supply.
- 4) Connect the positive terminal of DVM1 to OUT (TP1) and the negative terminal to the GND pad.
- 5) Connect the positive terminal of DVM2 to RS+ (TP4) and the negative terminal to RS- (TP5).
- 6) Turn on the +5V supply first and then the +14V supply.
- 7) Set the electronic load to 250mA and turn the electronic load on. Observe the output at TP4 with DVM1. The output voltage should be approximately 90 times the voltage read on DVM2. Repeat for load currents of 500mA and 750mA.

Table 1. Jumper Table (JU1, JU2)

JUMPER	SHUNT POSITION	DESCRIPTION
JU1	1-2	Connects SHDN to VCC (shutdown)
	2-3*	Connects SHDN to GND (normal operation)
JU2	Open	REFIN is unconnected and can be connected externally to VCC/2 for bidirectional operation
	Closed*	Connects REFIN to GND; used for unidirectional operation

*Default position.

Additional Evaluation

- 1) Turn off the electronic load, remove the shunt from JU2, and apply +2.5V on REFIN (TP3). This is for bidirectional operation.
- 2) DVM1 should read +2.5V for the no-load case. Set the load to 250mA and observe the output at TP4 with DVM1. The amplified output is added to +2.5V. Set the load to -250mA by swapping the cables connected to P1 and P2. The output voltage is subtracted from +2.5V by the same amount.

Detailed Description of Hardware

The MAX9918 EV kit provides a proven layout for the MAX9918 current-sense amplifier. The MAX9918 measures the load current and provides an analog output voltage. The full-scale V_{SENSE} on the MAX9918 is 50mV, allowing for 1A max load with a 50m Ω current-sense resistor. Higher load currents can be accommodated by adding a current-sense resistor in parallel with R3. Exposed copper is available for adding another current-sense resistor and vias are also available for a through-hole resistor. RS+ (TP4) and RS- (TP5) are Kelvin connected.

Measuring the Load Current

The MAX9918 EV kit comes with a MAX9918ASA+ installed, which sets the gain externally through resistors R1 and R2. The current-sense resistor is 50m Ω . The output voltage is dependent on the sense current, current-sense resistor, and gain (eq. 1). For the MAX9918 EV kit, the current-sense resistor is 50m Ω and the gain is 89.7, which is set through resistors R1 and R2 (Table 2).

$$V_{OUT} = I_{SENSE} \times R_{SENSE} \times A_V \text{ (eq. 1)}$$

where R_{SENSE} is 50m Ω and A_V is 89.7 for the MAX9918 EV kit by default.

Bidirectional Operation

The MAX9918 EV kit can be configured for bidirectional operation by removing the shunt on JU2 and applying VCC/2 on REFIN (TP3). That sets the bias voltage to VCC/2 for a no-current condition. Current in the positive direction in reference to RS+ and RS- increases the output voltage from VCC/2 and current in the negative direction decreases the output voltage from VCC/2 (eq. 2).

$$V_{OUT} = (I_{SENSE} \times R_{SENSE} \times A_V) + \frac{V_{CC}}{2} \text{ (eq. 2)}$$

MAX9918 Evaluation Kit

Evaluating the MAX9919 and MAX9920

Both versions of the MAX9919 have fixed gains and do not require gain-setting feedback resistors. Remove R1 and R2 to evaluate the MAX9919.

The MAX9920's gain is shown in Table 2. For the same R1 and R2 values, the MAX9920 has a lower gain, which allows a wider input range for a given current-sense resistor.

Table 2. Gain (A_v) Table

PART	GAIN (A _v)
MAX9918	$\left(1 + \frac{R2}{R1}\right)$
MAX9919F	45
MAX9919N	90
MAX9920	$\left(\frac{\left(1 + \frac{R2}{R1}\right)}{4}\right)$

Evaluates: MAX9918/MAX9919/MAX99206

MAX9918 Evaluation Kit

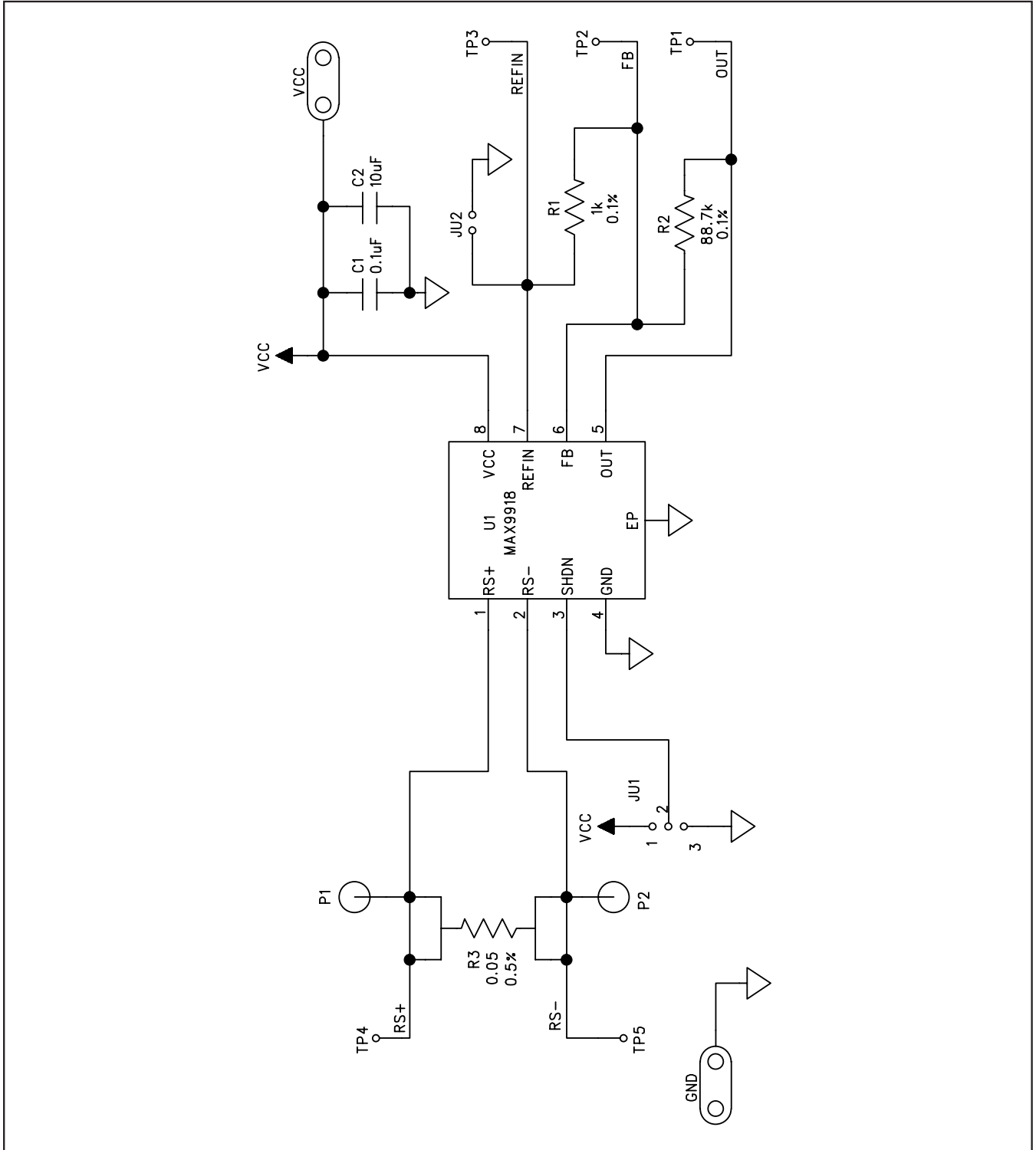

Figure 1. MAX9918 EV Kit Schematic

MAX9918 Evaluation Kit

Evaluates: MAX9918/MAX9919/MAX99206

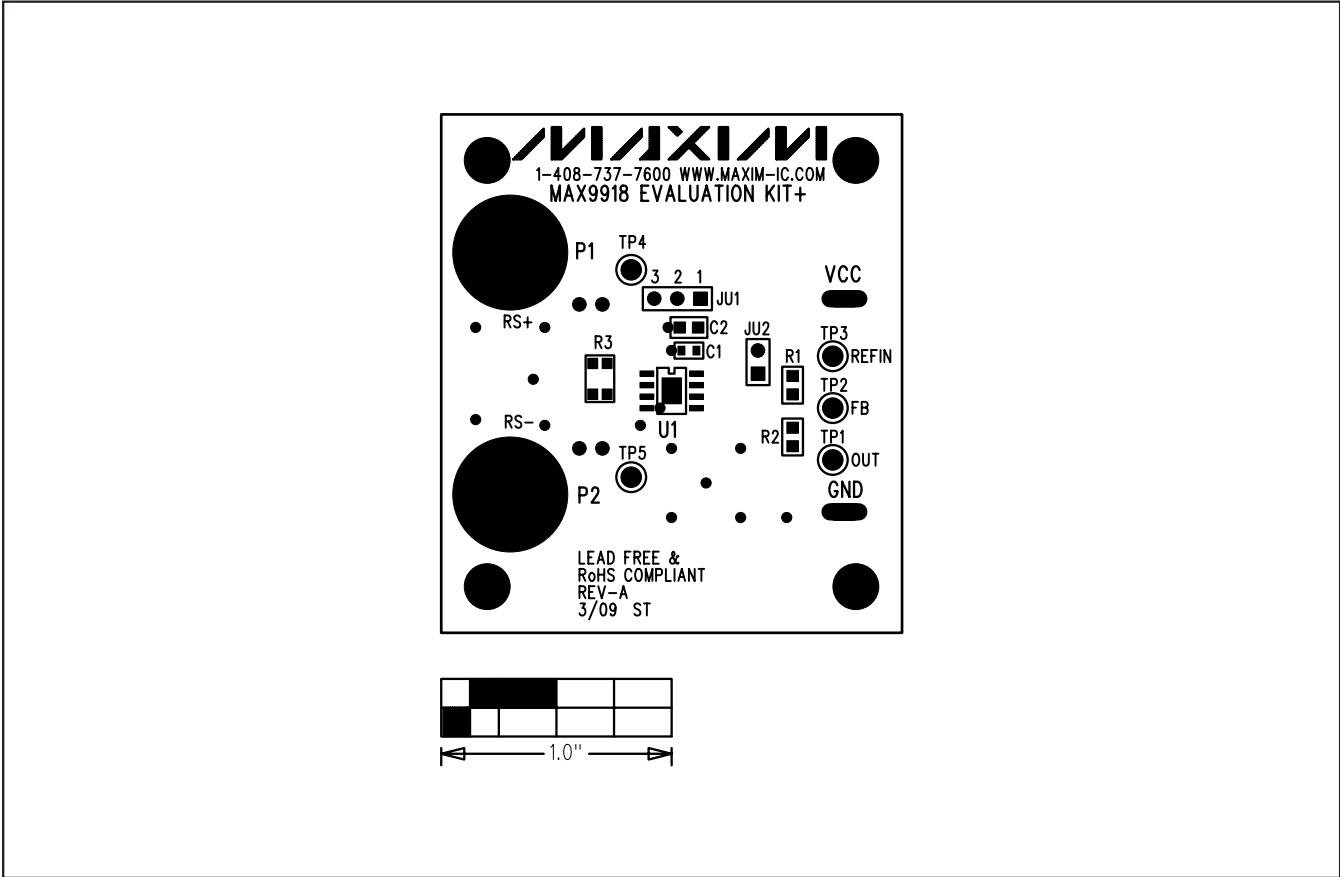

Figure 2. MAX9918 EV Kit Component Placement Guide—Component Side

MAX9918 Evaluation Kit

Evaluates: MAX9918/MAX9919/MAX9920

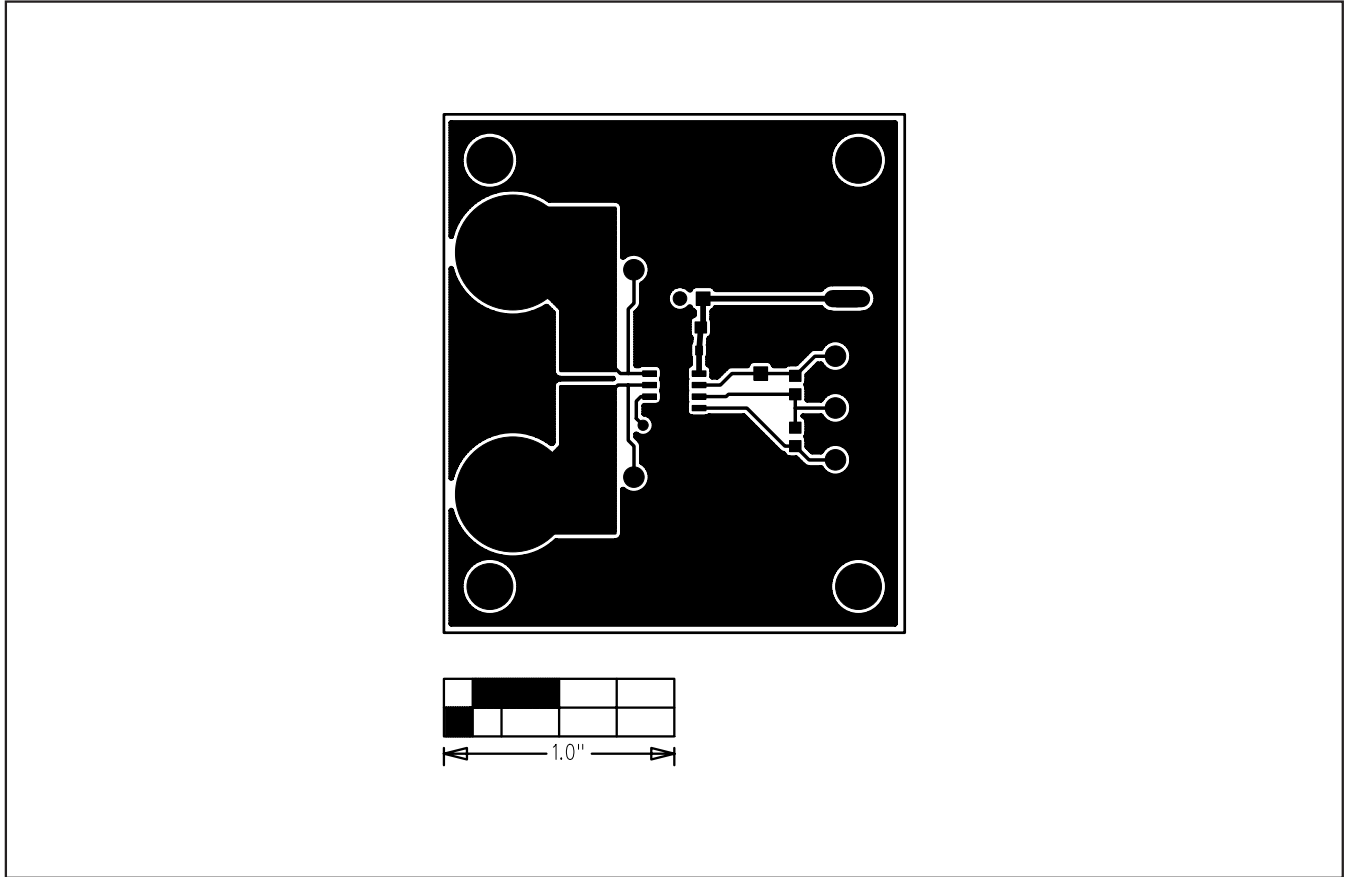

Figure 3. MAX9918 EV Kit PCB Layout—Component Side

MAX9918 Evaluation Kit

Evaluates: MAX9918/MAX9919/MAX9920

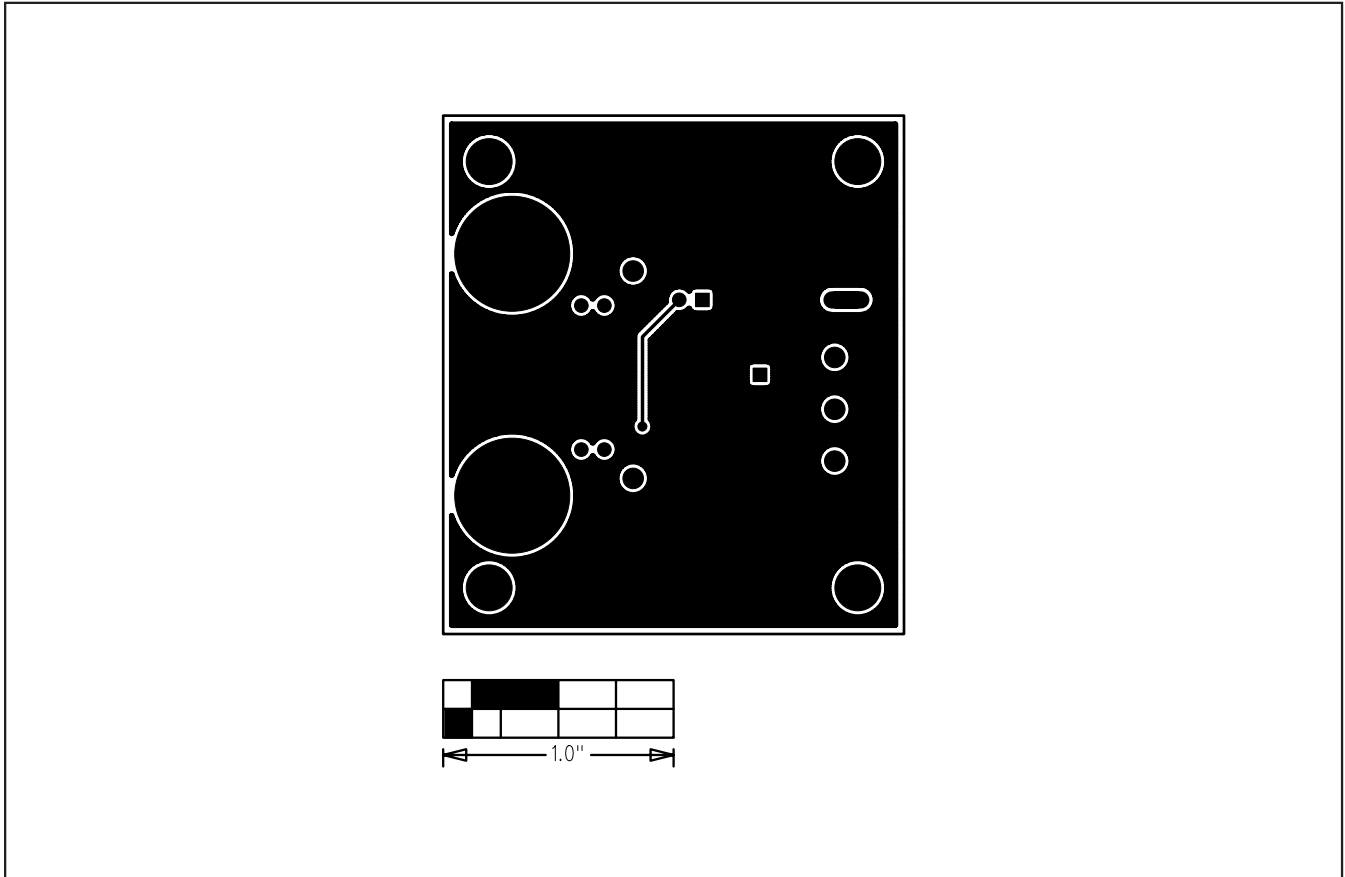

Figure 4. MAX9918 EV Kit PCB Layout—Solder Side

Maxim cannot assume responsibility for use of any circuitry other than circuitry entirely embodied in a Maxim product. No circuit patent licenses are implied. Maxim reserves the right to change the circuitry and specifications without notice at any time.

Maxim Integrated Products, 120 San Gabriel Drive, Sunnyvale, CA 94086 408-737-7600 _____ 7

Компания «Life Electronics» занимается поставками электронных компонентов импортного и отечественного производства от производителей и со складов крупных дистрибьюторов Европы, Америки и Азии.

С конца 2013 года компания активно расширяет линейку поставок компонентов по направлению коаксиальный кабель, кварцевые генераторы и конденсаторы (керамические, пленочные, электролитические), за счёт заключения дистрибьюторских договоров

Мы предлагаем:

- Конкурентоспособные цены и скидки постоянным клиентам.
- Специальные условия для постоянных клиентов.
- Подбор аналогов.
- Поставку компонентов в любых объемах, удовлетворяющих вашим потребностям.
- Приемлемые сроки поставки, возможна ускоренная поставка.
- Доставку товара в любую точку России и стран СНГ.
- Комплексную поставку.
- Работу по проектам и поставку образцов.
- Формирование склада под заказчика.
- Сертификаты соответствия на поставляемую продукцию (по желанию клиента).
- Тестирование поставляемой продукции.
- Поставку компонентов, требующих военную и космическую приемку.
- Входной контроль качества.
- Наличие сертификата ISO.

В составе нашей компании организован Конструкторский отдел, призванный помогать разработчикам, и инженерам.

Конструкторский отдел помогает осуществить:

- Регистрацию проекта у производителя компонентов.
- Техническую поддержку проекта.
- Защиту от снятия компонента с производства.
- Оценку стоимости проекта по компонентам.
- Изготовление тестовой платы монтаж и пусконаладочные работы.



Тел: +7 (812) 336 43 04 (многоканальный)

Email: org@lifeelectronics.ru