

Stand-Alone CAN Controller with SPI™ Interface

Features

- Implements Full CAN V2.0A and V2.0B at 1 Mb/s:
 - 0 - 8 byte message length
 - Standard and extended data frames
 - Programmable bit rate up to 1 Mb/s
 - Support for remote frames
 - Two receive buffers with prioritized message storage
 - Six full acceptance filters
 - Two full acceptance filter masks
 - Three transmit buffers with prioritization and abort features
 - Loop-back mode for self test operation
- Hardware Features:
 - High Speed SPI Interface (5 MHz at 4.5V I temp)
 - Supports SPI modes 0,0 and 1,1
 - Clock out pin with programmable prescaler
 - Interrupt output pin with selectable enables
 - 'Buffer full' output pins configureable as interrupt pins for each receive buffer or as general purpose digital outputs
 - 'Request to Send' input pins configureable as control pins to request immediate message transmission for each transmit buffer or as general purpose digital inputs
 - Low Power Sleep mode
- Low power CMOS technology:
 - Operates from 3.0V to 5.5V
 - 5 mA active current typical
 - 10 µA standby current typical at 5.5V
- 18-pin PDIP/SOIC and 20-pin TSSOP packages
- Temperature ranges supported:
 - Industrial (I): -40°C to +85°C
 - Extended (E): -40°C to +125°C

Description

The Microchip Technology Inc. MCP2510 is a Full Controller Area Network (CAN) protocol controller implementing CAN specification V2.0 A/B. It supports CAN 1.2, CAN 2.0A, CAN 2.0B Passive, and CAN 2.0B Active versions of the protocol, and is capable of transmitting and receiving standard and extended messages. It is also capable of both acceptance filtering and message management. It includes three transmit buffers and two receive buffers that reduce the amount of microcontroller (MCU) management required. The MCU communication is implemented via an industry standard Serial Peripheral Interface (SPI) with data rates up to 5 Mb/s.

Package Types

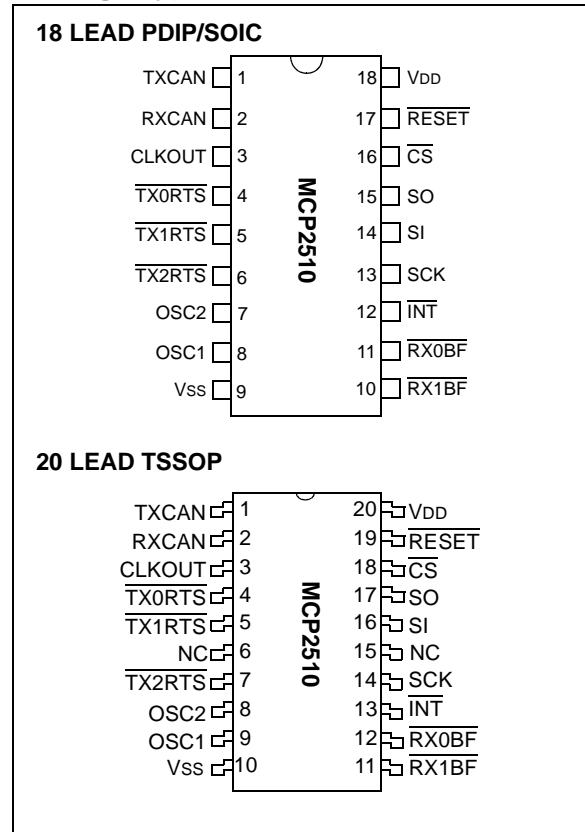

MCP2510

Table of Contents

1.0	Device Functionality	3
2.0	Can Message Frames	7
3.0	Message Transmission	15
4.0	Message Reception	21
5.0	Bit Timing	35
6.0	Error Detection	41
7.0	Interrupts	45
8.0	Oscillator	49
9.0	Modes of Operation	51
10.0	Register Map	55
11.0	SPI Interface	57
12.0	Electrical Characteristics	61
13.0	Packaging Information	65
	Index	69
	On-Line Support	71
	Reader Response	72
	Product Identification System	73
	Worldwide Sales and Service	76

TO OUR VALUED CUSTOMERS

It is our intention to provide our valued customers with the best documentation possible to ensure successful use of your Microchip products. To this end, we will continue to improve our publications to better suit your needs. Our publications will be refined and enhanced as new volumes and updates are introduced.

If you have any questions or comments regarding this publication, please contact the Marketing Communications Department via E-mail at docerrors@microchip.com or fax the **Reader Response Form** in the back of this data sheet to (480) 792-4150. We welcome your feedback.

Most Current Data Sheet

To obtain the most up-to-date version of this data sheet, please register at our Worldwide Web site at:

<http://www.microchip.com>

You can determine the version of a data sheet by examining its literature number found on the bottom outside corner of any page. The last character of the literature number is the version number, (e.g., DS30000A is version A of document DS30000).

Errata

An errata sheet, describing minor operational differences from the data sheet and recommended workarounds, may exist for current devices. As device/documentation issues become known to us, we will publish an errata sheet. The errata will specify the revision of silicon and revision of document to which it applies.

To determine if an errata sheet exists for a particular device, please check with one of the following:

- Microchip's Worldwide Web site; <http://www.microchip.com>
- Your local Microchip sales office (see last page)

When contacting a sales office, please specify which device, revision of silicon and data sheet (include literature number) you are using.

Customer Notification System

Register on our web site at www.microchip.com to receive the most current information on all of our products.

1.0 DEVICE FUNCTIONALITY

1.1 Overview

The MCP2510 is a stand-alone CAN controller developed to simplify applications that require interfacing with a CAN bus. A simple block diagram of the MCP2510 is shown in Figure 1-1. The device consists of three main blocks:

1. The CAN protocol engine.
2. The control logic and SRAM registers that are used to configure the device and its operation.
3. The SPI protocol block.

A typical system implementation using the device is shown in Figure 1-2.

The CAN protocol engine handles all functions for receiving and transmitting messages on the bus. Messages are transmitted by first loading the appropriate message buffer and control registers. Transmission is initiated by using control register bits, via the SPI interface, or by using the transmit enable pins. Status and errors can be checked by reading the appropriate registers. Any message detected on the CAN bus is

checked for errors and then matched against the user defined filters to see if it should be moved into one of the two receive buffers.

The MCU interfaces to the device via the SPI interface. Writing to and reading from all registers is done using standard SPI read and write commands.

Interrupt pins are provided to allow greater system flexibility. There is one multi-purpose interrupt pin as well as specific interrupt pins for each of the receive registers that can be used to indicate when a valid message has been received and loaded into one of the receive buffers. Use of the specific interrupt pins is optional, and the general purpose interrupt pin as well as status registers (accessed via the SPI interface) can also be used to determine when a valid message has been received.

There are also three pins available to initiate immediate transmission of a message that has been loaded into one of the three transmit registers. Use of these pins is optional and initiating message transmission can also be done by utilizing control registers accessed via the SPI interface.

Table 1-1 gives a complete list of all of the pins on the MCP2510.

FIGURE 1-1: BLOCK DIAGRAM

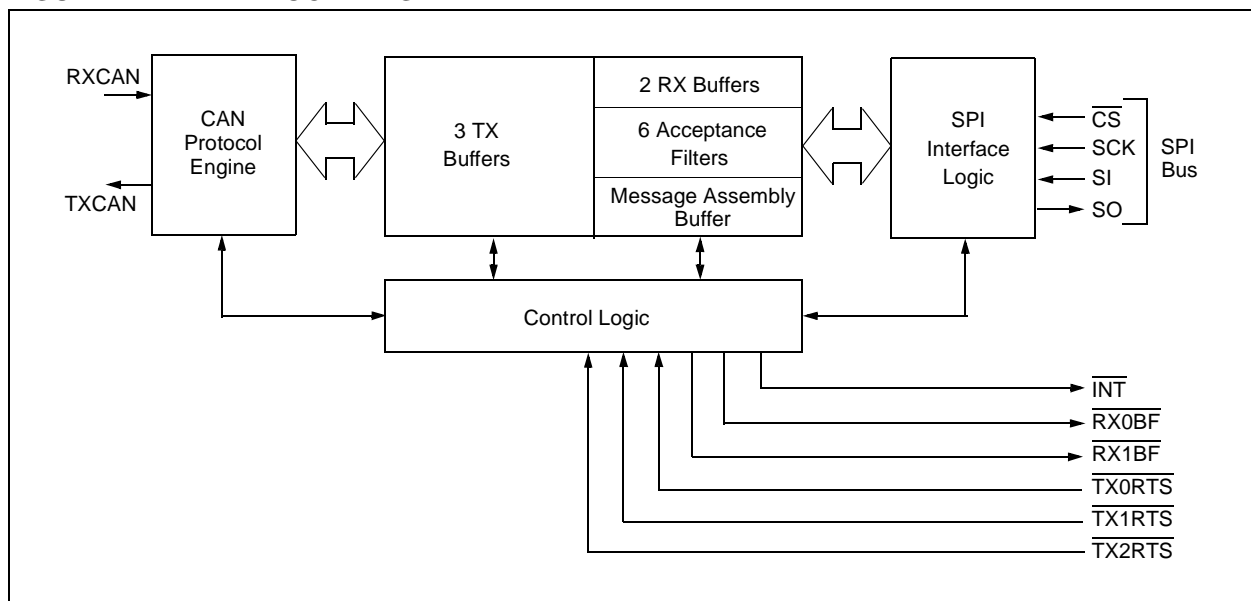

MCP2510

FIGURE 1-2: TYPICAL SYSTEM IMPLEMENTATION

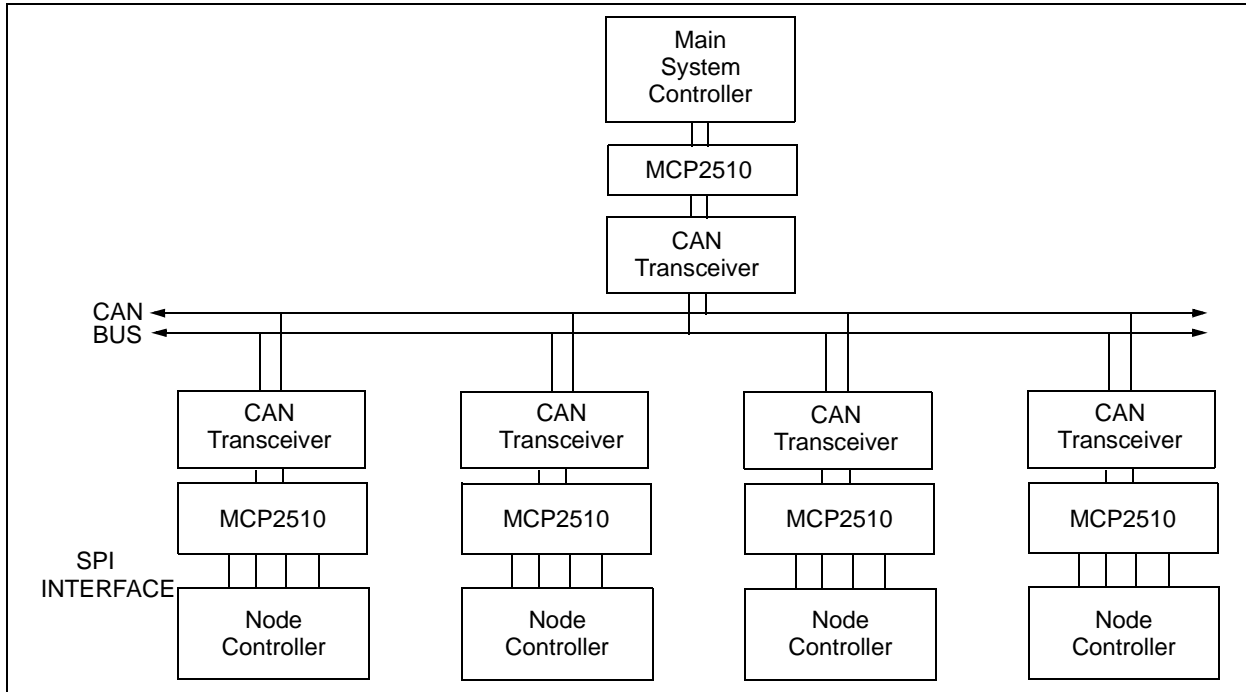

TABLE 1-1: PIN DESCRIPTIONS

Name	DIP/ SOIC Pin #	TSSOP Pin #	I/O/P Type	Description
TXCAN	1	1	O	Transmit output pin to CAN bus
RXCAN	2	2	I	Receive input pin from CAN bus
CLKOUT	3	3	O	Clock output pin with programmable prescaler
TX0RTS	4	4	I	Transmit buffer TXB0 request to send or general purpose digital input. 100 kΩ internal pullup to VDD
TX1RTS	5	5	I	Transmit buffer TXB1 request to send or general purpose digital input. 100 kΩ internal pullup to VDD
TX2RTS	6	7	I	Transmit buffer TXB2 request to send or general purpose digital input. 100 kΩ internal pullup to VDD
OSC2	7	8	O	Oscillator output
OSC1	8	9	I	Oscillator input
Vss	9	10	P	Ground reference for logic and I/O pins
RX1BF	10	11	O	Receive buffer RXB1 interrupt pin or general purpose digital output
RX0BF	11	12	O	Receive buffer RXB0 interrupt pin or general purpose digital output
INT	12	13	O	Interrupt output pin
SCK	13	14	I	Clock input pin for SPI interface
SI	14	16	I	Data input pin for SPI interface
SO	15	17	O	Data output pin for SPI interface
CS	16	18	I	Chip select input pin for SPI interface
RESET	17	19	I	Active low device reset input
VDD	18	20	P	Positive supply for logic and I/O pins
NC	—	6,15	—	No internal connection

Note: Type Identification: I=Input; O=Output; P=Power

1.2 Transmit/Receive Buffers

The MCP2510 has three transmit and two receive buffers, two acceptance masks (one for each receive buffer), and a total of six acceptance filters. Figure 1-3 is a block diagram of these buffers and their connection to the protocol engine.

FIGURE 1-3: CAN BUFFERS AND PROTOCOL ENGINE BLOCK DIAGRAM

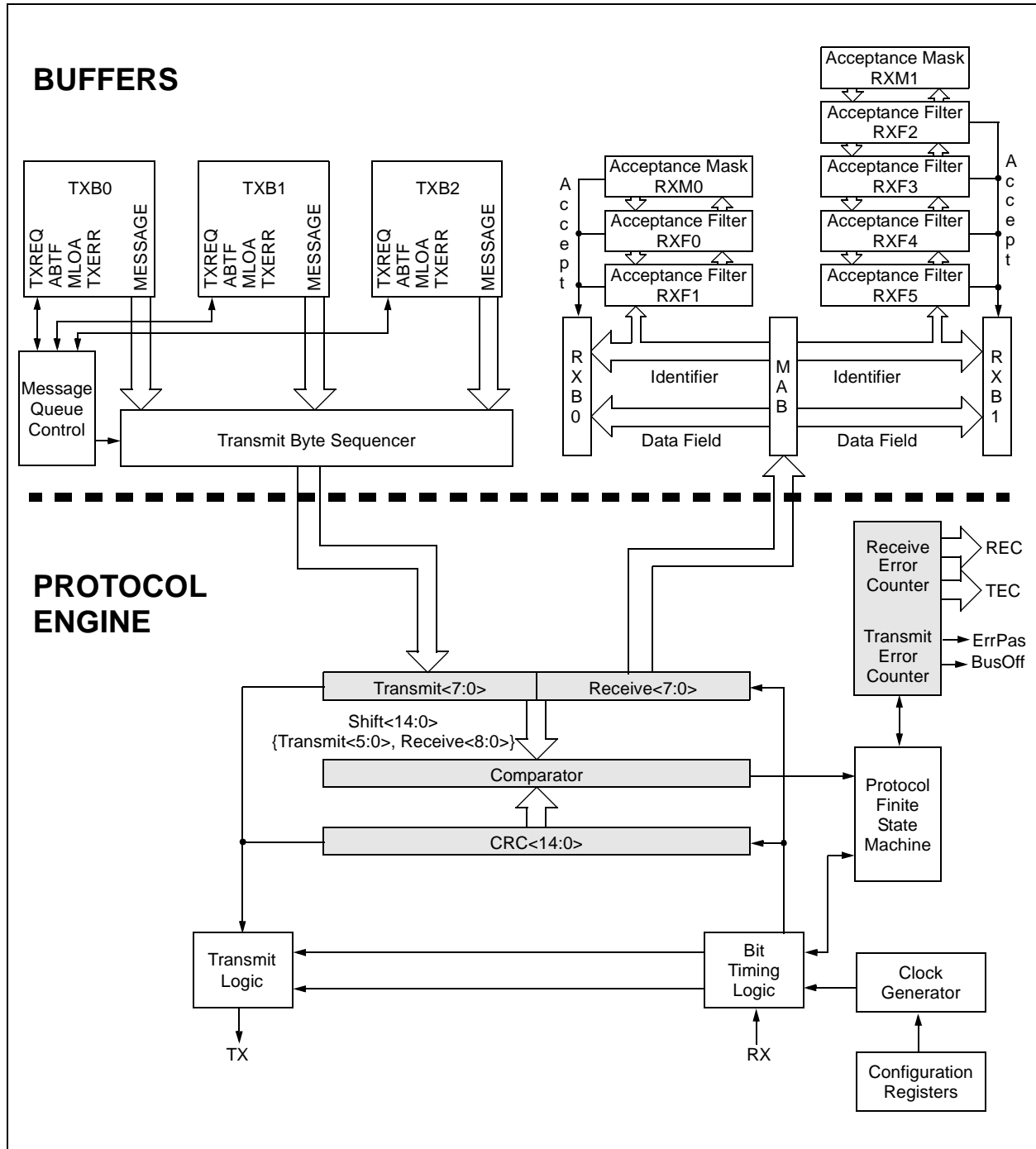

MCP2510

1.3 CAN Protocol Engine

The CAN protocol engine combines several functional blocks, shown in Figure 1-4. These blocks and their functions are described below.

1.4 Protocol Finite State Machine

The heart of the engine is the Finite State Machine (FSM). This state machine sequences through messages on a bit by bit basis, changing states as the fields of the various frame types are transmitted or received. The FSM is a sequencer controlling the sequential data stream between the TX/RX Shift Register, the CRC Register, and the bus line. The FSM also controls the Error Management Logic (EML) and the parallel data stream between the TX/RX Shift Registers and the buffers. The FSM insures that the processes of reception, arbitration, transmission, and error signaling are performed according to the CAN protocol. The automatic retransmission of messages on the bus line is also handled by the FSM.

1.5 Cyclic Redundancy Check

The Cyclic Redundancy Check Register generates the Cyclic Redundancy Check (CRC) code which is transmitted after either the Control Field (for messages with 0 data bytes) or the Data Field, and is used to check the CRC field of incoming messages.

1.6 Error Management Logic

The Error Management Logic is responsible for the fault confinement of the CAN device. Its two counters, the Receive Error Counter (REC) and the Transmit Error Counter (TEC), are incremented and decremented by commands from the Bit Stream Processor. According to the values of the error counters, the CAN controller is set into the states error-active, error-passive or bus-off.

1.7 Bit Timing Logic

The Bit Timing Logic (BTL) monitors the bus line input and handles the bus related bit timing according to the CAN protocol. The BTL synchronizes on a recessive to dominant bus transition at Start of Frame (hard synchronization) and on any further recessive to dominant bus line transition if the CAN controller itself does not transmit a dominant bit (resynchronization). The BTL also provides programmable time segments to compensate for the propagation delay time, phase shifts, and to define the position of the Sample Point within the bit time. The programming of the BTL depends upon the baud rate and external physical delay times.

FIGURE 1-4: CAN PROTOCOL ENGINE BLOCK DIAGRAM

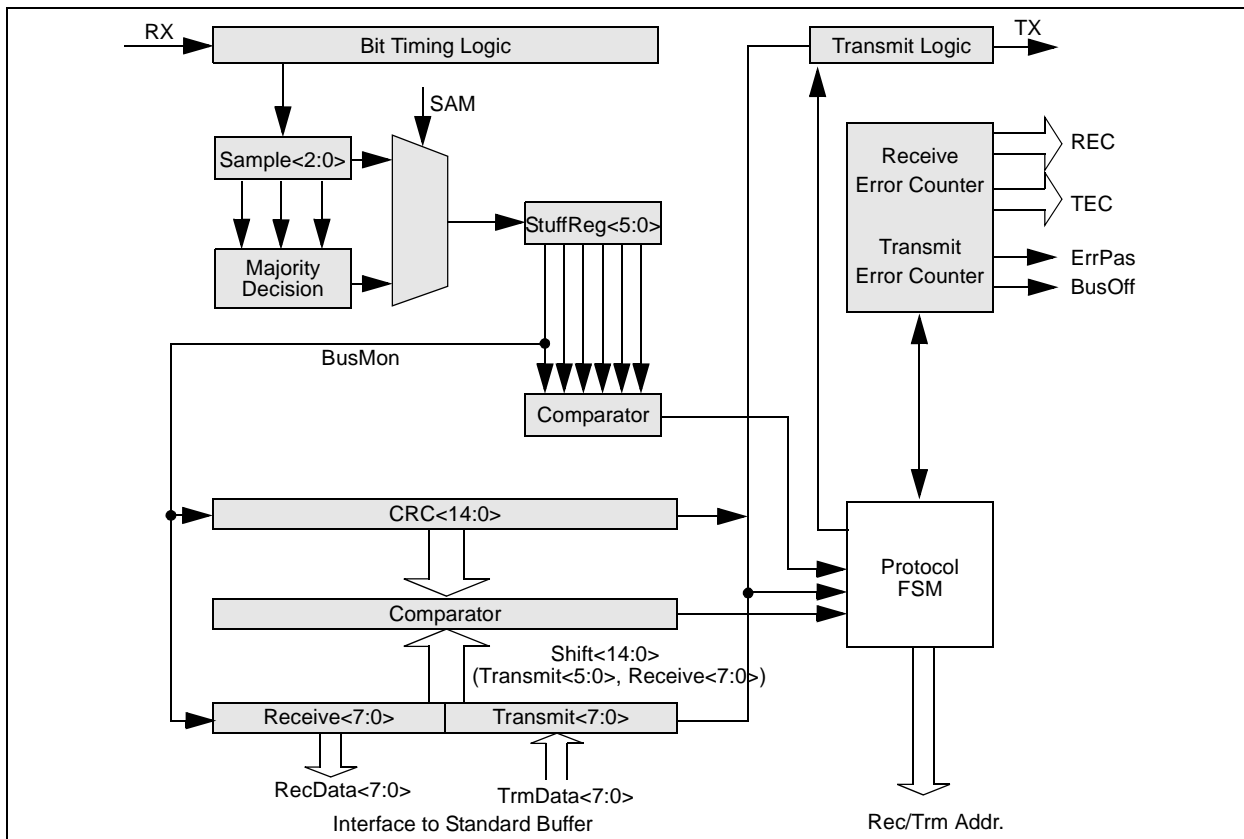

2.0 CAN MESSAGE FRAMES

The MCP2510 supports Standard Data Frames, Extended Data Frames, and Remote Frames (Standard and Extended) as defined in the CAN 2.0B specification.

2.1 Standard Data Frame

The CAN Standard Data Frame is shown in Figure 2-1. In common with all other frames, the frame begins with a Start Of Frame (SOF) bit, which is of the dominant state, which allows hard synchronization of all nodes.

The SOF is followed by the arbitration field, consisting of 12 bits; the 11-bit Identifier and the Remote Transmission Request (RTR) bit. The RTR bit is used to distinguish a data frame (RTR bit dominant) from a remote frame (RTR bit recessive).

Following the arbitration field is the control field, consisting of six bits. The first bit of this field is the Identifier Extension (IDE) bit which must be dominant to specify a standard frame. The following bit, Reserved Bit Zero (RB0), is reserved and is defined to be a dominant bit by the CAN protocol. The remaining four bits of the control field are the Data Length Code (DLC) which specifies the number of bytes of data contained in the message.

After the control field is the data field, which contains any data bytes that are being sent, and is of the length defined by the DLC above (0-8 bytes).

The Cyclic Redundancy Check (CRC) Field follows the data field and is used to detect transmission errors. The CRC Field consists of a 15-bit CRC sequence, followed by the recessive CRC Delimiter bit.

The final field is the two-bit acknowledge field. During the ACK Slot bit, the transmitting node sends out a recessive bit. Any node that has received an error free frame acknowledges the correct reception of the frame by sending back a dominant bit (regardless of whether the node is configured to accept that specific message or not). The recessive acknowledge delimiter completes the acknowledge field and may not be overwritten by a dominant bit.

2.2 Extended Data Frame

In the Extended CAN Data Frame, the SOF bit is followed by the arbitration field which consists of 32 bits, as shown in Figure 2-2. The first 11 bits are the most significant bits (Base-ID) of the 29-bit identifier. These 11 bits are followed by the Substitute Remote Request (SRR) bit which is defined to be recessive. The SRR bit is followed by the IDE bit which is recessive to denote an extended CAN frame.

It should be noted that if arbitration remains unresolved after transmission of the first 11 bits of the identifier, and one of the nodes involved in the arbitration is sending a standard CAN frame (11-bit identifier), then the stan-

dard CAN frame will win arbitration due to the assertion of a dominant IDE bit. Also, the SRR bit in an extended CAN frame must be recessive to allow the assertion of a dominant RTR bit by a node that is sending a standard CAN remote frame.

The SRR and IDE bits are followed by the remaining 18 bits of the identifier (Extended ID) and the remote transmission request bit.

To enable standard and extended frames to be sent across a shared network, it is necessary to split the 29-bit extended message identifier into 11-bit (most significant) and 18-bit (least significant) sections. This split ensures that the IDE bit can remain at the same bit position in both standard and extended frames.

Following the arbitration field is the six-bit control field. The first two bits of this field are reserved and must be dominant. The remaining four bits of the control field are the Data Length Code (DLC) which specifies the number of data bytes contained in the message.

The remaining portion of the frame (data field, CRC field, acknowledge field, end of frame and Intermission) is constructed in the same way as for a standard data frame (see Section 2.1).

2.3 Remote Frame

Normally, data transmission is performed on an autonomous basis by the data source node (e.g. a sensor sending out a data frame). It is possible, however, for a destination node to request data from the source. To accomplish this, the destination node sends a remote frame with an identifier that matches the identifier of the required data frame. The appropriate data source node will then send a data frame in response to the remote frame request.

There are two differences between a remote frame (shown in Figure 2-3) and a data frame. First, the RTR bit is at the recessive state, and second, there is no data field. In the event of a data frame and a remote frame with the same identifier being transmitted at the same time, the data frame wins arbitration due to the dominant RTR bit following the identifier. In this way, the node that transmitted the remote frame receives the desired data immediately.

2.4 Error Frame

An Error Frame is generated by any node that detects a bus error. An error frame, shown in Figure 2-4, consists of two fields, an error flag field followed by an error delimiter field. There are two types of error flag fields. Which type of error flag field is sent depends upon the error status of the node that detects and generates the error flag field.

If an error-active node detects a bus error then the node interrupts transmission of the current message by generating an active error flag. The active error flag is composed of six consecutive dominant bits. This bit

sequence actively violates the bit stuffing rule. All other stations recognize the resulting bit stuffing error and in turn generate error frames themselves, called error echo flags. The error flag field, therefore, consists of between six and twelve consecutive dominant bits (generated by one or more nodes). The error delimiter field completes the error frame. After completion of the error frame, bus activity returns to normal and the interrupted node attempts to resend the aborted message.

If an error-passive node detects a bus error then the node transmits an error-passive flag followed by the error delimiter field. The error-passive flag consists of six consecutive recessive bits, and the error frame for an error-passive node consists of 14 recessive bits. From this, it follows that unless the bus error is detected by the node that is actually transmitting, the transmission of an error frame by an error-passive node will not affect any other node on the network. If the transmitting node generates an error-passive flag then this will cause other nodes to generate error frames due to the resulting bit stuffing violation. After transmission of an error frame, an error-passive node must wait for six consecutive recessive bits on the bus before attempting to rejoin bus communications.

The error delimiter consists of eight recessive bits and allows the bus nodes to restart bus communications cleanly after an error has occurred.

2.5 Overload Frame

An Overload Frame, shown in Figure 2-5, has the same format as an active error frame. An overload frame, however can only be generated during an Interframe space. In this way an overload frame can be differentiated from an error frame (an error frame is sent during the transmission of a message). The overload frame consists of two fields, an overload flag followed by an overload delimiter. The overload flag consists of six dominant bits followed by overload flags generated by other nodes (and, as for an active error flag, giving a maximum of twelve dominant bits). The overload delimiter consists of eight recessive bits. An overload frame can be generated by a node as a result of two conditions. First, the node detects a dominant bit during the interframe space which is an illegal condition. Second, due to internal conditions the node is not yet able to start reception of the next message. A node may generate a maximum of two sequential overload frames to delay the start of the next message.

2.6 Interframe Space

The Interframe Space separates a preceeding frame (of any type) from a subsequent data or remote frame. The interframe space is composed of at least three recessive bits called the Intermission. This is provided to allow nodes time for internal processing before the start of the next message frame. After the intermission, the bus line remains in the recessive state (bus idle) until the next transmission starts.

FIGURE 2-1: STANDARD DATA FRAME

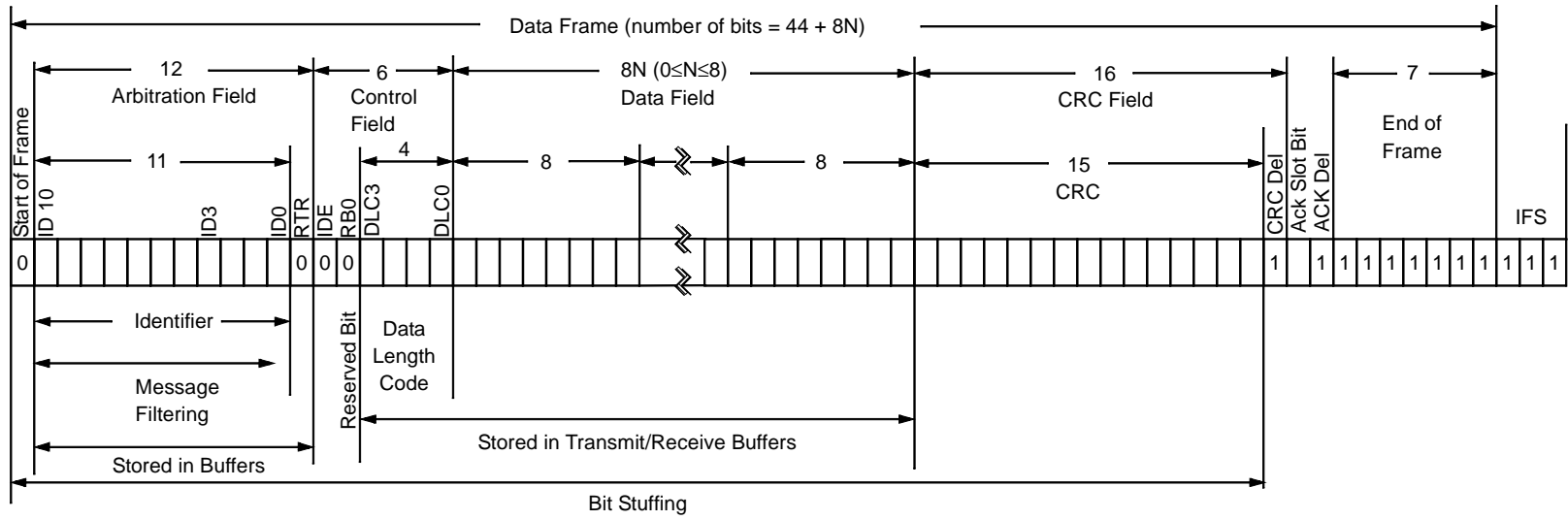

FIGURE 2-2: EXTENDED DATA FRAME

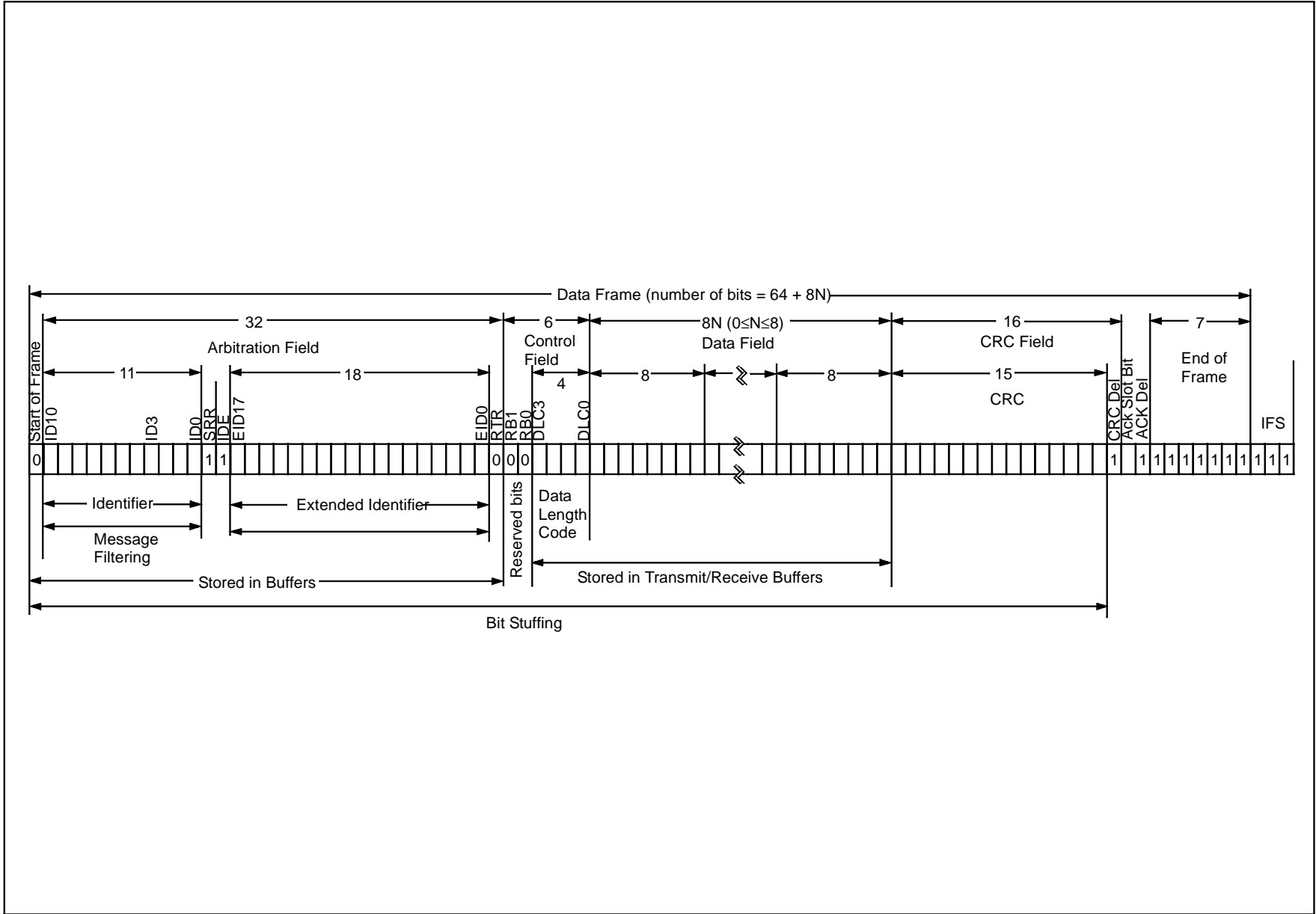
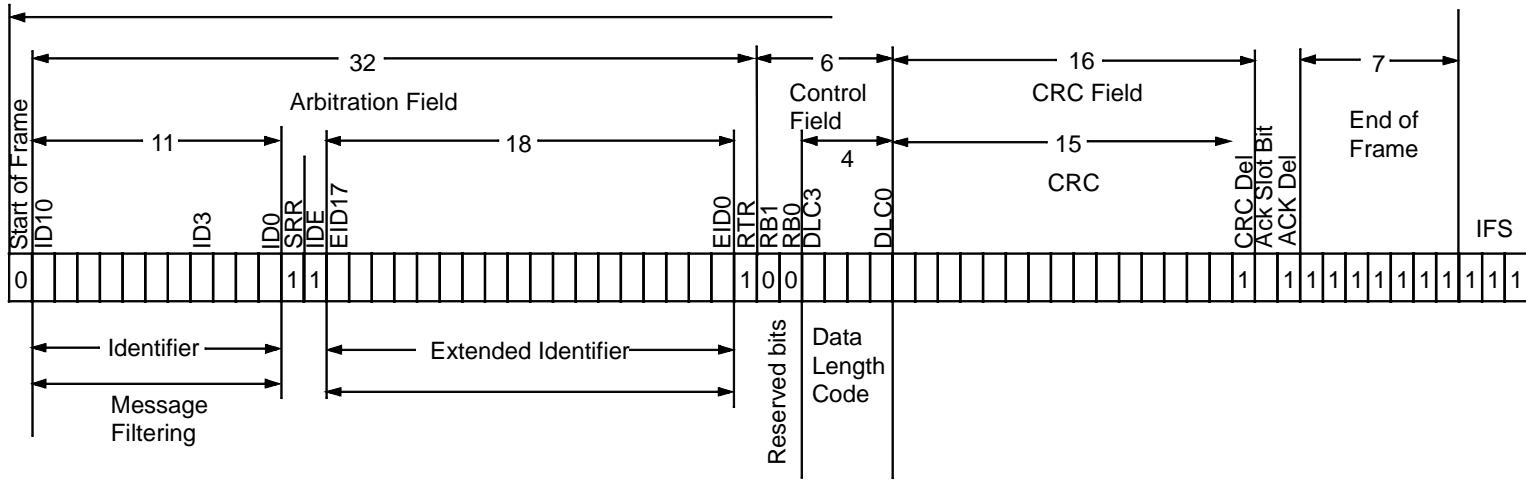

FIGURE 2-3: REMOTE DATA FRAME



Remote Data Frame with Extended Identifier

FIGURE 2-4: ERROR DATA FRAME

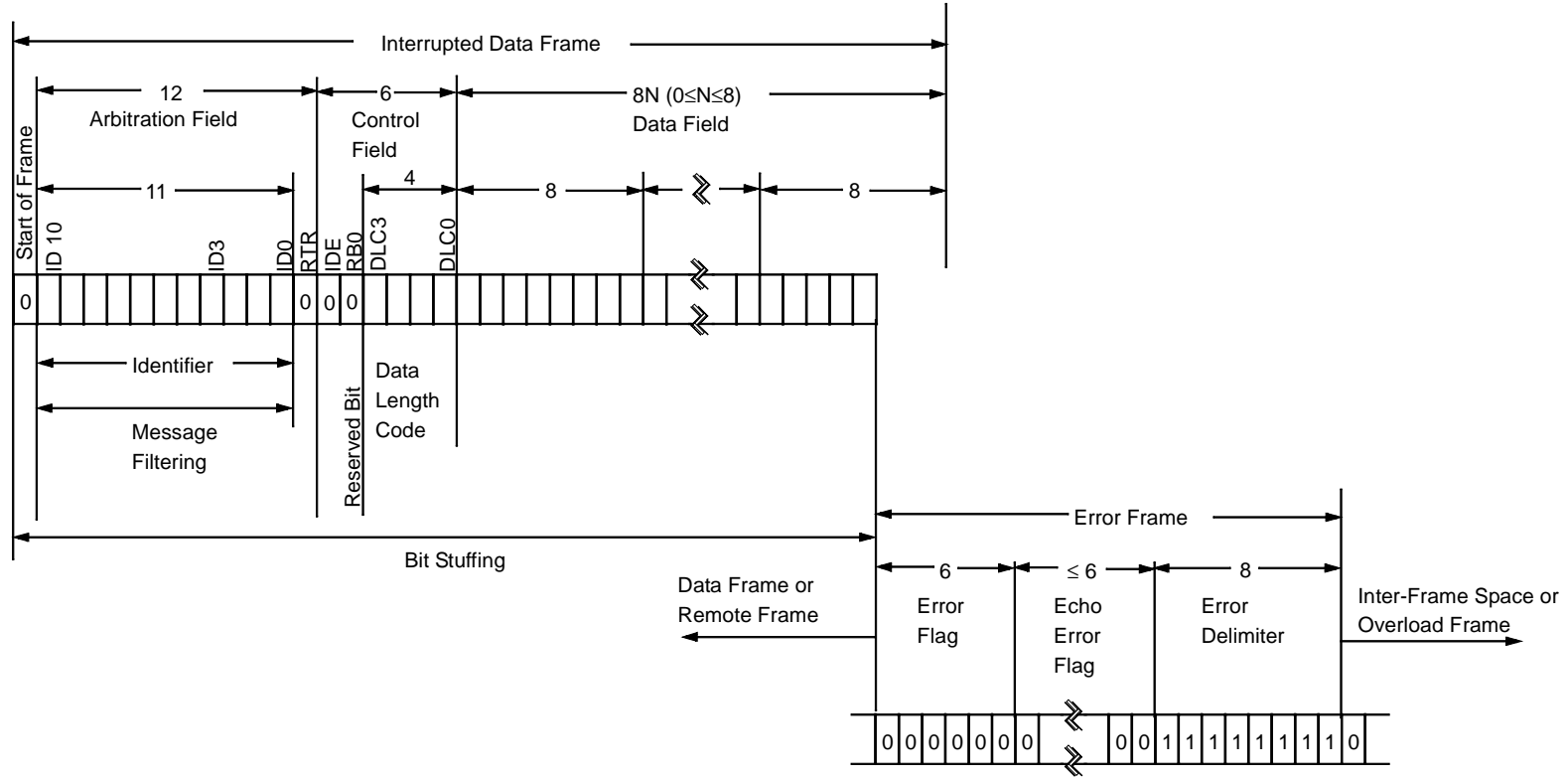
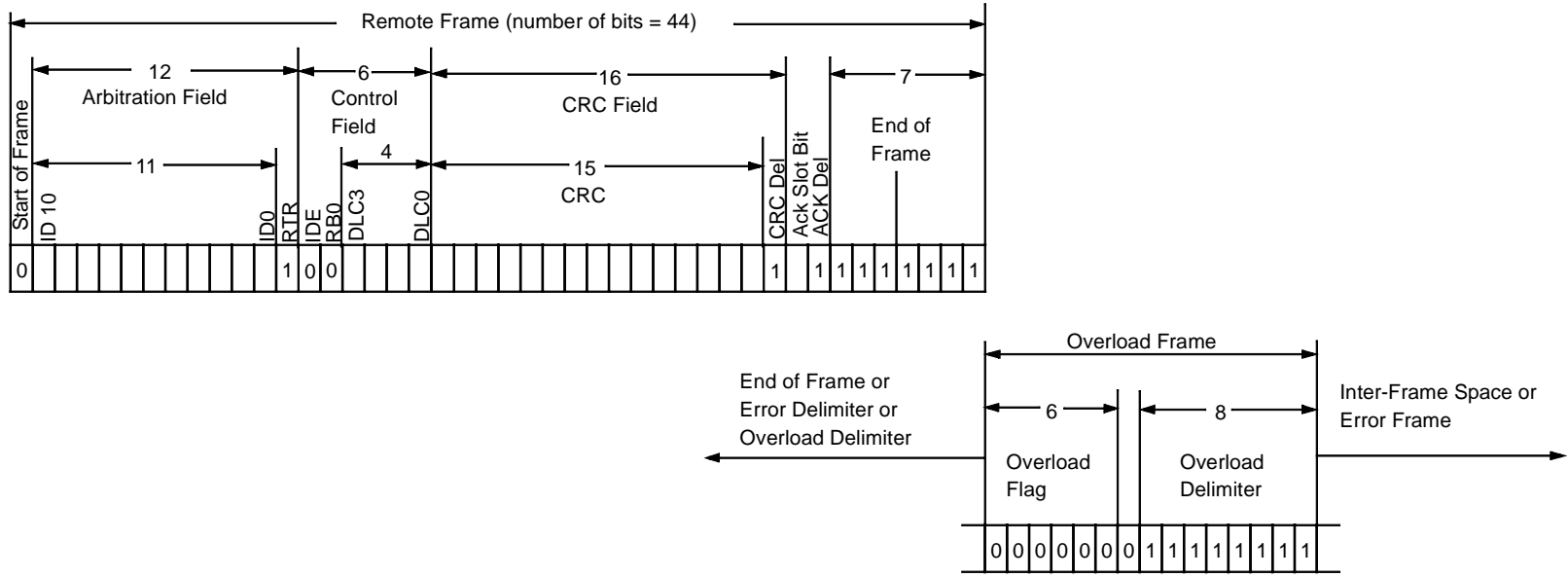

FIGURE 2-5: OVERLOAD FRAME



MCP2510

NOTES:

3.0 MESSAGE TRANSMISSION

3.1 Transmit Buffers

The MCP2510 implements three Transmit Buffers. Each of these buffers occupies 14 bytes of SRAM and are mapped into the device memory maps. The first byte, TXBNCCTRL, is a control register associated with the message buffer. The information in this register determines the conditions under which the message will be transmitted and indicates the status of the message transmission. (see Register 3-2). Five bytes are used to hold the standard and extended identifiers and other message arbitration information (see Register 3-3 through Register 3-8). The last eight bytes are for the eight possible data bytes of the message to be transmitted (see Register 3-8).

For the MCU to have write access to the message buffer, the TXBNCCTRL.TXREQ bit must be clear, indicating that the message buffer is clear of any pending message to be transmitted. At a minimum, the TXBNSIDH, TXBNSIDL, and TXBNDLC registers must be loaded. If data bytes are present in the message, the TXBNDm registers must also be loaded. If the message is to use extended identifiers, the TXBNEIDm registers must also be loaded and the TXBNSIDL.EXIDE bit set.

Prior to sending the message, the MCU must initialize the CANINTE.TXINE bit to enable or disable the generation of an interrupt when the message is sent. The MCU must also initialize the TXBNCCTRL.TXP priority bits (see Section 3.2).

3.2 Transmit Priority

Transmit priority is a prioritization, within the MCP2510, of the pending transmittable messages. This is independent from, and not necessarily related to, any prioritization implicit in the message arbitration scheme built into the CAN protocol. Prior to sending the SOF, the priority of all buffers that are queued for transmission is compared. The transmit buffer with the highest priority will be sent first. For example, if transmit buffer 0 has a higher priority setting than transmit buffer 1, buffer 0 will be sent first. If two buffers have the same priority setting, the buffer with the highest buffer number will be sent first. For example, if transmit buffer 1 has the same priority setting as transmit buffer 0, buffer 1 will be sent first. There are four levels of transmit priority. If TXBNCCTRL.TXP<1:0> for a particular message buffer is set to 11, that buffer has the highest possible priority. If TXBNCCTRL.TXP<1:0> for a particular message buffer is 00, that buffer has the lowest possible priority.

3.3 Initiating Transmission

To initiate message transmission the TXBNCCTRL.TXREQ bit must be set for each buffer to be transmitted. This can be done by writing to the register via the SPI interface or by setting the $\overline{\text{TXNRTS}}$ pin low for the particular transmit buffer(s) that are to be transmit-

ted. If transmission is initiated via the SPI interface, the TXREQ bit can be set at the same time as the TXP priority bits.

When TXBNCCTRL.TXREQ is set, the TXBNCCTRL.ABTF, TXBNCCTRL.MLOA and TXBNCCTRL.TXERR bits will be cleared.

Setting the TXBNCCTRL.TXREQ bit does not initiate a message transmission, it merely flags a message buffer as ready for transmission. Transmission will start when the device detects that the bus is available. The device will then begin transmission of the highest priority message that is ready.

When the transmission has completed successfully the TXBNCCTRL.TXREQ bit will be cleared, the CANINTF.TXNIF bit will be set, and an interrupt will be generated if the CANINTE.TXNIE bit is set.

If the message transmission fails, the TXBNCCTRL.TXREQ will remain set indicating that the message is still pending for transmission and one of the following condition flags will be set. If the message started to transmit but encountered an error condition, the TXBNCCTRL.TXERR and the CANINTF.MERRF bits will be set and an interrupt will be generated on the $\overline{\text{INT}}$ pin if the CANINTE.MERRE bit is set. If the message lost arbitration the TXBNCCTRL.MLOA bit will be set.

3.4 TXnRTS Pins

The $\overline{\text{TXnRTS}}$ Pins are input pins that can be configured as request-to-send inputs, which provides a secondary means of initiating the transmission of a message from any of the transmit buffers, or as standard digital inputs. Configuration and control of these pins is accomplished using the TXRTSCTRL register (see Register 3-2). The TXRTSCTRL register can only be modified when the MCP2510 is in configuration mode (see Section 9.0). If configured to operate as a request to send pin, the pin is mapped into the respective TXBNCCTRL.TXREQ bit for the transmit buffer. The TXREQ bit is latched by the falling edge of the $\overline{\text{TXnRTS}}$ pin. The $\overline{\text{TXnRTS}}$ pins are designed to allow them to be tied directly to the RXNBF pins to automatically initiate a message transmission when the $\overline{\text{RXNBF}}$ pin goes low. The $\overline{\text{TXnRTS}}$ pins have internal pullup resistors of 100 k Ω (nominal).

3.5 Aborting Transmission

The MCU can request to abort a message in a specific message buffer by clearing the associated TXBNCCTRL.TXREQ bit. Also, all pending messages can be requested to be aborted by setting the CANCTRL.ABAT bit. If the CANCTRL.ABAT bit is set to abort all pending messages, the user MUST reset this bit (typically after the user verifies that all TXREQ bits have been cleared) to continue transmit messages. The CANCTRL.ABTF flag will only be set if the abort was requested via the CANCTRL.ABAT bit. Aborting a message by resetting the TXREQ bit does cause the ATBF bit to be set.

MCP2510

Only messages that have not already begun to be transmitted can be aborted. Once a message has begun transmission, it will not be possible for the user to reset the TXBnCTRL.TXREQ bit. After transmission

of a message has begun, if an error occurs on the bus or if the message loses arbitration, the message will be retransmitted regardless of a request to abort.

FIGURE 3-1: TRANSMIT MESSAGE FLOWCHART

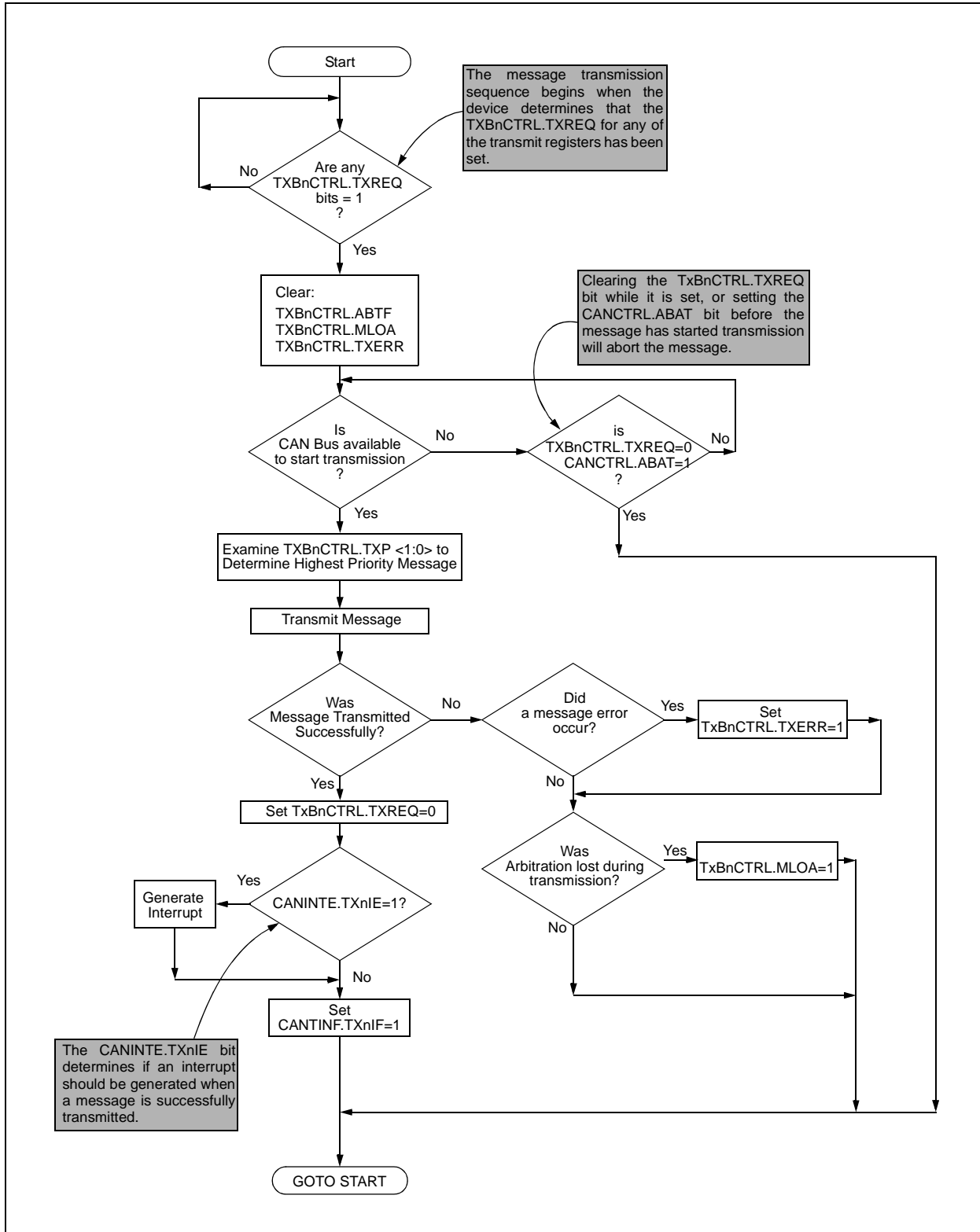

**REGISTER 3-1: TXBNCTRL Transmit Buffer N Control Register
(ADDRESS: 30h, 40h, 50h)**

U-0	R-0	R-0	R-0	R/W-0	U-0	R/W-0	R/W-0
—	ABTF	MLOA	TXERR	TXREQ	—	TXP1	TXP0
bit 7							bit 0

- bit 7 **Unimplemented:** Read as '0'
- bit 6 **ABTF:** Message Aborted Flag
1 = Message was aborted
0 = Message completed transmission successfully
- bit 5 **MLOA:** Message Lost Arbitration
1 = Message lost arbitration while being sent
0 = Message did not lose arbitration while being sent
- bit 4 **TXERR:** Transmission Error Detected
1 = A bus error occurred while the message was being transmitted
0 = No bus error occurred while the message was being transmitted
- bit 3 **TXREQ:** Message Transmit Request
1 = Buffer is currently pending transmission
 (MCU sets this bit to request message be transmitted - bit is automatically cleared when the message is sent)
0 = Buffer is not currently pending transmission
 (MCU can clear this bit to request a message abort)
- bit 2 **Unimplemented:** Read as '0'
- bit 1-0 **TXP<1:0>:** Transmit Buffer Priority
11 = Highest Message Priority
10 = High Intermediate Message Priority
11 = Low Intermediate Message Priority
00 = Lowest Message Priority

Legend:			
R = Readable bit	W = Writable bit	U = Unimplemented bit, read as '0'	
-n = Value at POR	'1' = Bit is set	'0' = Bit is cleared	x = Bit is unknown

MCP2510

REGISTER 3-2: TXRTSCTRL - TXNRTS PIN CONTROL AND STATUS REGISTER (ADDRESS: 0Dh)

U-0	U-0	R-x	R-x	R-x	R/W-0	R/W-0	R/W-0	
—	—	B2RTS	B1RTS	B0RTS	B2RTSM	B1RTSM	B0RTSM	
bit 7								bit 0

- bit 7 **Unimplemented:** Read as '0'
- bit 6 **Unimplemented:** Read as '0'
- bit 5 **B2RTS:** $\overline{\text{TX2RTS}}$ Pin State
 - Reads state of $\overline{\text{TX2RTS}}$ pin when in digital input mode
 - Reads as '0' when pin is in 'request to send' mode
- bit 4 **B1RTS:** $\overline{\text{TX1RTS}}$ Pin State
 - Reads state of $\overline{\text{TX1RTS}}$ pin when in digital input mode
 - Reads as '0' when pin is in 'request to send' mode
- bit 3 **B0RTS:** $\overline{\text{TX0RTS}}$ Pin State
 - Reads state of $\overline{\text{TX0RTS}}$ pin when in digital input mode
 - Reads as '0' when pin is in 'request to send' mode
- bit 2 **B2RTSM:** $\overline{\text{TX2RTS}}$ Pin Mode
 1 = Pin is used to request message transmission of TXB2 buffer (on falling edge)
 0 = Digital input
- bit 1 **B1RTSM:** $\overline{\text{TX1RTS}}$ Pin Mode
 1 = Pin is used to request message transmission of TXB1 buffer (on falling edge)
 0 = Digital input
- bit 0 **B0RTSM:** $\overline{\text{TX0RTS}}$ Pin Mode
 1 = Pin is used to request message transmission of TXB0 buffer (on falling edge)
 0 = Digital input

Legend:			
R = Readable bit	W = Writable bit	U = Unimplemented bit, read as '0'	
-n = Value at POR	'1' = Bit is set	'0' = Bit is cleared	x = Bit is unknown

REGISTER 3-3: TXBN SIDH - TRANSMIT BUFFER N STANDARD IDENTIFIER HIGH (ADDRESS: 31h, 41h, 51h)

R/W-x	R/W-x	R/W-x	R/W-x	R/W-x	R/W-x	R/W-x	R/W-x
SID10	SID9	SID8	SID7	SID6	SID5	SID4	SID3
bit 7						bit 0	

- bit 7-0 **SID<10:3>:** Standard Identifier Bits <10:3>

Legend:			
R = Readable bit	W = Writable bit	U = Unimplemented bit, read as '0'	
-n = Value at POR	'1' = Bit is set	'0' = Bit is cleared	x = Bit is unknown

**REGISTER 3-4: TXBNSIDL - Transmit Buffer N Standard Identifier Low
(ADDRESS: 32h, 42h, 52h)**

R/W-x	R/W-x	R/W-x	R/W-x	R/W-x	R/W-x	R/W-x	R/W-x
SID2	SID1	SID0	—	EXIDE	—	EID17	EID16
bit 7				bit 0			

- bit 7-5 **SID<2:0>**: Standard Identifier Bits <2:0>
- bit 4 **Unimplemented**: Reads as '0'
- bit 3 **EXIDE**: Extended Identifier Enable
1 = Message will transmit extended identifier
0 = Message will transmit standard identifier
- bit 2 **Unimplemented**: Reads as '0'
- bit 1-0 **EID<17:16>**: Extended Identifier Bits <17:16>

Legend:		
R = Readable bit	W = Writable bit	U = Unimplemented bit, read as '0'
-n = Value at POR	'1' = Bit is set	'0' = Bit is cleared x = Bit is unknown

**REGISTER 3-5: TXBNEID8 - TRANSMIT BUFFER N EXTENDED IDENTIFIER HIGH
(ADDRESS: 33h, 43h, 53h)**

R/W-x	R/W-x	R/W-x	R/W-x	R/W-x	R/W-x	R/W-x	R/W-x
EID15	EID14	EID13	EID12	EID11	EID10	EID9	EID8
bit 7				bit 0			

- bit 7-0 **EID<15:8>**: Extended Identifier Bits <15:8>

Legend:		
R = Readable bit	W = Writable bit	U = Unimplemented bit, read as '0'
-n = Value at POR	'1' = Bit is set	'0' = Bit is cleared x = Bit is unknown

**REGISTER 3-6: TXBNEID0 - TRANSMIT BUFFER N EXTENDED IDENTIFIER LOW
(ADDRESS: 34h, 44h, 54h)**

R/W-x	R/W-x	R/W-x	R/W-x	R/W-x	R/W-x	R/W-x	R/W-x
EID7	EID6	EID5	EID4	EID3	EID2	EID1	EID0
bit 7				bit 0			

- bit 7-0 **EID<7:0>**: Extended Identifier Bits <7:0>

Legend:		
R = Readable bit	W = Writable bit	U = Unimplemented bit, read as '0'
-n = Value at POR	'1' = Bit is set	'0' = Bit is cleared x = Bit is unknown

MCP2510

**REGISTER 3-7: TXBNDLC - Transmit Buffer N Data Length Code
(ADDRESS: 35h, 45h, 55h)**

R/W-x	R/W-x	R/W-x	R/W-x	R/W-x	R/W-x	R/W-x	R/W-x
—	RTR	—	—	DLC3	DLC2	DLC1	DLC0
bit 7				bit 0			

bit 7 **Unimplemented:** Reads as '0'

bit 6 **RTR:** Remote Transmission Request Bit
 1 = Transmitted Message will be a Remote Transmit Request
 0 = Transmitted Message will be a Data Frame

bit 5-4 **Unimplemented:** Reads as '0'

bit 3-0 **DLC<3:0>:** Data Length Code
 Sets the number of data bytes to be transmitted (0 to 8 bytes)

Note: It is possible to set the DLC to a value greater than 8, however only 8 bytes are transmitted

Legend:			
R = Readable bit	W = Writable bit	U = Unimplemented bit, read as '0'	
-n = Value at POR	'1' = Bit is set	'0' = Bit is cleared	x = Bit is unknown

**REGISTER 3-8: TXBNDM - Transmit Buffer N Data Field Byte m
(ADDRESS: 36h-3Dh, 46h-4Dh, 56h-5Dh)**

R/W-x	R/W-x	R/W-x	R/W-x	R/W-x	R/W-x	R/W-x	R/W-x
TXBNDm	TXBNDm	TXBNDm	TXBNDm	TXBNDm	TXBNDm	TXBNDm	TXBNDm
7	6	5	4	3	2	1	0
bit 7				bit 0			

bit 7-0 **TXBNDM7:TXBNDM0:** Transmit Buffer N Data Field Byte m

Legend:			
R = Readable bit	W = Writable bit	U = Unimplemented bit, read as '0'	
-n = Value at POR	'1' = Bit is set	'0' = Bit is cleared	x = Bit is unknown

4.0 MESSAGE RECEPTION

4.1 Receive Message Buffering

The MCP2510 includes two full receive buffers with multiple acceptance filters for each. There is also a separate Message Assembly Buffer (MAB) which acts as a third receive buffer (see Figure 4-1).

4.2 Receive Buffers

Of the three Receive Buffers, the MAB is always committed to receiving the next message from the bus. The remaining two receive buffers are called RXB0 and RXB1 and can receive a complete message from the protocol engine. The MCU can access one buffer while the other buffer is available for message reception or holding a previously received message.

The MAB assembles all messages received. These messages will be transferred to the RXBN buffers (See Register 4-4 to Register 4-9) only if the acceptance filter criteria are met.

Note: The entire contents of the MAB is moved into the receive buffer once a message is accepted. This means that regardless of the type of identifier (standard or extended) and the number of data bytes received, the entire receive buffer is overwritten with the MAB contents. Therefore the contents of all registers in the buffer must be assumed to have been modified when any message is received.

When a message is moved into either of the receive buffers the appropriate CANINTF.RXNIF bit is set. This bit must be cleared by the MCU, when it has completed processing the message in the buffer, in order to allow a new message to be received into the buffer. This bit provides a positive lockout to ensure that the MCU has finished with the message before the MCP2510 attempts to load a new message into the receive buffer. If the CANINTE.RXNIE bit is set an interrupt will be generated on the INT pin to indicate that a valid message has been received.

4.3 Receive Priority

RXB0 is the higher priority buffer and has two message acceptance filters associated with it. RXB1 is the lower priority buffer and has four acceptance filters associated with it. The lower number of acceptance filters makes the match on RXB0 more restrictive and implies a higher priority for that buffer. Additionally, the RXB0CTRL register can be configured such that if RXB0 contains a valid message, and another valid message is received, an overflow error will not occur and the new message will be moved into RXB1 regardless of the acceptance criteria of RXB1. There are also two programmable acceptance filter masks available, one for each receive buffer (see Section 4.5).

When a message is received, bits <3:0> of the RXBNCTRL Register will indicate the acceptance filter number that enabled reception, and whether the received message is a remote transfer request.

The RXBNCTRL.RXM bits set special receive modes. Normally, these bits are set to 00 to enable reception of all valid messages as determined by the appropriate acceptance filters. In this case, the determination of whether or not to receive standard or extended messages is determined by the RFXNSIDL.EXIDE bit in the acceptance filter register. If the RXBNCTRL.RXM bits are set to 01 or 10, the receiver will accept only messages with standard or extended identifiers respectively. If an acceptance filter has the RFXNSIDL.EXIDE bit set such that it does not correspond with the RXBNCTRL.RXM mode, that acceptance filter is rendered useless. These two modes of RXBNCTRL.RXM bits can be used in systems where it is known that only standard or extended messages will be on the bus. If the RXBNCTRL.RXM bits are set to 11, the buffer will receive all messages regardless of the values of the acceptance filters. Also, if a message has an error before the end of frame, that portion of the message assembled in the MAB before the error frame will be loaded into the buffer. This mode has some value in debugging a CAN system and would not be used in an actual system environment.

4.4 RX0BF and RX1BF Pins

In addition to the INT pin which provides an interrupt signal to the MCU for many different conditions, the receive buffer full pins (RX0BF and RX1BF) can be used to indicate that a valid message has been loaded into RXB0 or RXB1, respectively.

The RXBNBF full pins can be configured to act as buffer full interrupt pins or as standard digital outputs. Configuration and status of these pins is available via the BFPCTRL register (Register 4-3). When set to operate in interrupt mode (by setting BFPCTRL.BxBFE and BFPCTRL.BxBFM bits to a 1), these pins are active low and are mapped to the CANINTF.RXNIF bit for each receive buffer. When this bit goes high for one of the receive buffers, indicating that a valid message has been loaded into the buffer, the corresponding RXNBF pin will go low. When the CANINTF.RXNIF bit is cleared by the MCU, then the corresponding interrupt pin will go to the logic high state until the next message is loaded into the receive buffer.

When used as digital outputs, the BFPCTRL.BxBFM bits must be cleared to a '0' and BFPCTRL.BxBFE bits must be set to a '1' for the associated buffer. In this mode the state of the pin is controlled by the BFPCTRL.BxBFS bits. Writing a '1' to the BxBFS bit will cause a high level to be driven on the associated buffer full pin, and a '0' will cause the pin to drive low. When using the pins in this mode the state of the pin should be modified only by using the Bit Modify SPI command to prevent glitches from occurring on either of the buffer full pins.

FIGURE 4-2: MESSAGE RECEPTION FLOWCHART

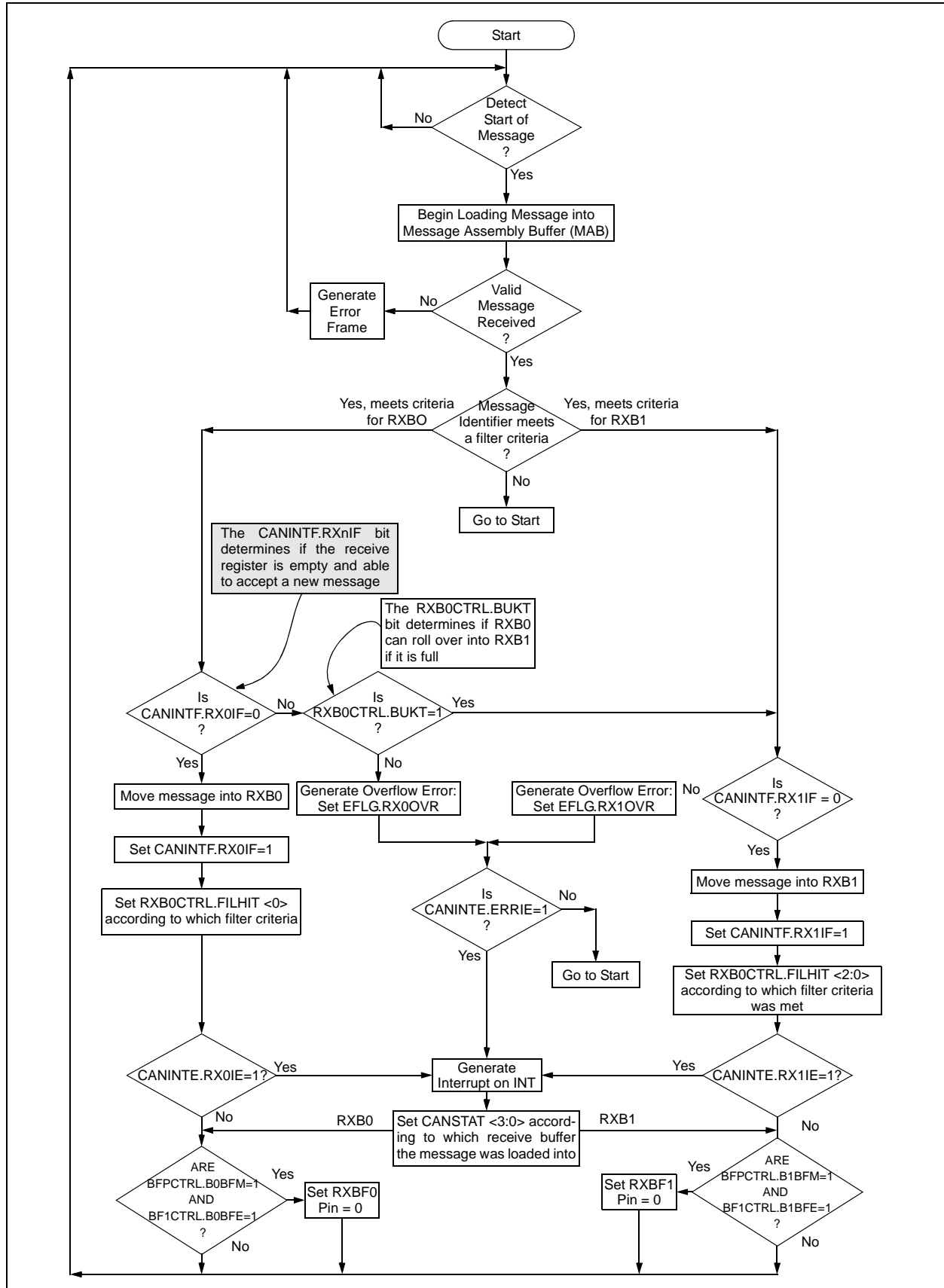

MCP2510

REGISTER 4-1: RXB0CTRL - RECEIVE BUFFER 0 CONTROL REGISTER (ADDRESS: 60h)

U-0	R/W-0	R/W-0	U-0	R-0	R/W-0	R-0	R-0
—	RXM1	RXM0	—	RXRTR	BUKT	BUKT1	FILHIT0
bit 7							bit 0

bit 7 **Unimplemented:** Read as '0'

bit 6-5 **RXM<1:0>:** Receive Buffer Operating Mode

11 = Turn mask/filters off; receive any message

10 = Receive only valid messages with extended identifiers that meet filter criteria

01 = Receive only valid messages with standard identifiers that meet filter criteria

00 = Receive all valid messages using either standard or extended identifiers that meet filter criteria

bit 4 **Unimplemented:** Read as '0'

bit 3 **RXRTR:** Received Remote Transfer Request

1 = Remote Transfer Request Received

0 = No Remote Transfer Request Received

bit 2 **BUKT:** Rollover Enable

1 = RXB0 message will rollover and be written to RXB1 if RXB0 is full

0 = Rollover disabled

bit 1 **BUKT1:** Read Only Copy of BUKT Bit (used internally by the MCP2510).

bit 0 **FILHIT<0>:** Filter Hit - indicates which acceptance filter enabled reception of message

1 = Acceptance Filter 1 (RXF1)

0 = Acceptance Filter 0 (RXF0)

Note: If a rollover from RXB0 to RXB1 occurs, the FILHIT bit will reflect the filter that accepted the message that rolled over

Legend:

R = Readable bit

W = Writable bit

U = Unimplemented bit, read as '0'

-n = Value at POR

'1' = Bit is set

'0' = Bit is cleared

x = Bit is unknown

**REGISTER 4-2: RXB1CTRL - RECEIVE BUFFER 1 CONTROL REGISTER
(ADDRESS: 70h)**

U-0	R/W-0	R/W-0	U-0	R-0	R-0	R-0	R-0
—	RXM1	RXM0	—	RXRTR	FILHIT2	FILHIT1	FILHIT0
bit 7							bit 0

bit 7 **Unimplemented:** Read as '0'

bit 6-5 **RXM<1:0>:** Receive Buffer Operating Mode

11 = Turn mask/filters off; receive any message

10 = Receive only valid messages with extended identifiers that meet filter criteria

01 = Receive only valid messages with standard identifiers that meet filter criteria

00 = Receive all valid messages using either standard or extended identifiers that meet filter criteria

bit 4 **Unimplemented:** Read as '0'

bit 3 **RXRTR:** Received Remote Transfer Request

1 = Remote Transfer Request Received

0 = No Remote Transfer Request Received

bit 2-0 **FILHIT<2:0>:** Filter Hit - indicates which acceptance filter enabled reception of message

101 = Acceptance Filter 5 (RXF5)

100 = Acceptance Filter 4 (RXF4)

011 = Acceptance Filter 3 (RXF3)

010 = Acceptance Filter 2 (RXF2)

001 = Acceptance Filter 1 (RXF1) (Only if BUKT bit set in RXB0CTRL)

000 = Acceptance Filter 0 (RXF0) (Only if BUKT bit set in RXB0CTRL)

Legend:

R = Readable bit

W = Writable bit

U = Unimplemented bit, read as '0'

-n = Value at POR

'1' = Bit is set

'0' = Bit is cleared

x = Bit is unknown

MCP2510

REGISTER 4-3: BFPCTRL - RXNBF PIN CONTROL AND STATUS REGISTER (ADDRESS: 0Ch)

U-0	U-0	R/W-0	R/W-0	R/W-0	R/W-0	R/W-0	R/W-0	
—	—	B1BFS	B0BFS	B1BFE	B0BFE	B1BFM	B0BFM	
bit 7								bit 0

- bit 7 **Unimplemented:** Read as '0'
- bit 6 **Unimplemented:** Read as '0'
- bit 5 **B1BFS:** $\overline{\text{RX1BF}}$ Pin State (digital output mode only)
- Reads as '0' when RX1BF is configured as interrupt pin
- bit 4 **B0BFS:** $\overline{\text{RX0BF}}$ Pin State (digital output mode only)
- Reads as '0' when RX0BF is configured as interrupt pin
- bit 3 **B1BFE:** $\overline{\text{RX1BF}}$ Pin Function Enable
1 = Pin function enabled, operation mode determined by B1BFM bit
0 = Pin function disabled, pin goes to high impedance state
- bit 2 **B0BFE:** $\overline{\text{RX0BF}}$ Pin Function Enable
1 = Pin function enabled, operation mode determined by B0BFM bit
0 = Pin Function disabled, pin goes to high impedance state
- bit 1 **B1BFM:** $\overline{\text{RX1BF}}$ Pin Operation Mode
1 = Pin is used as interrupt when valid message loaded into RXB1
0 = Digital output mode
- bit 0 **B0BFM:** $\overline{\text{RX0BF}}$ Pin Operation Mode
1 = Pin is used as interrupt when valid message loaded into RXB0
0 = Digital output mode

Legend:			
R = Readable bit	W = Writable bit	U = Unimplemented bit, read as '0'	
-n = Value at POR	'1' = Bit is set	'0' = Bit is cleared	x = Bit is unknown

REGISTER 4-4: RXBnSIDH - RECEIVE BUFFER n STANDARD IDENTIFIER HIGH (ADDRESS: 61h, 71h)

R-x	R-x	R-x	R-x	R-x	R-x	R-x	R-x	
SID10	SID9	SID8	SID7	SID6	SID5	SID4	SID3	
bit 7								bit 0

- bit 7-0 **SID<10:3>:** Standard Identifier Bits <10:3>
These bits contain the eight most significant bits of the Standard Identifier for the received message

Legend:			
R = Readable bit	W = Writable bit	U = Unimplemented bit, read as '0'	
-n = Value at POR	'1' = Bit is set	'0' = Bit is cleared	x = Bit is unknown

**REGISTER 4-5: RXBNSIDL - RECEIVE BUFFER N STANDARD IDENTIFIER LOW
(ADDRESS: 62h, 72h)**

R-x	R-x	R-x	R-x	R-x	U-0	R-x	R-x
SID2	SID1	SID0	SRR	IDE	—	EID17	EID16
bit 7						bit 0	

- bit 7-5 **SID<2:0>**: Standard Identifier Bits <2:0>
These bits contain the three least significant bits of the Standard Identifier for the received message
- bit 4 **SRR**: Standard Frame Remote Transmit Request Bit (valid only if IDE bit = '0')
1 = Standard Frame Remote Transmit Request Received
0 = Standard Data Frame Received
- bit 3 **IDE**: Extended Identifier Flag
This bit indicates whether the received message was a Standard or an Extended Frame
1 = Received message was an Extended Frame
0 = Received message was a Standard Frame
- bit 2 **Unimplemented**: Reads as '0'
- bit 1-0 **EID<17:16>**: Extended Identifier Bits <17:16>
These bits contain the two most significant bits of the Extended Identifier for the received message

Legend:			
R = Readable bit	W = Writable bit	U = Unimplemented bit, read as '0'	
-n = Value at POR	'1' = Bit is set	'0' = Bit is cleared	x = Bit is unknown

**REGISTER 4-6: RXBNEID8 - RECEIVE BUFFER N EXTENDED IDENTIFIER MID
(ADDRESS: 63h, 73h)**

R-x	R-x	R-x	R-x	R-x	R-x	R-x	R-x
EID15	EID14	EID13	EID12	EID11	EID10	EID9	EID8
bit 7							bit 0

- bit 7-0 **EID<15:8>**: Extended Identifier Bits <15:8>
These bits hold bits 15 through 8 of the Extended Identifier for the received message

Legend:			
R = Readable bit	W = Writable bit	U = Unimplemented bit, read as '0'	
-n = Value at POR	'1' = Bit is set	'0' = Bit is cleared	x = Bit is unknown

MCP2510

REGISTER 4-7: RXBNEID0 - RECEIVE BUFFER N EXTENDED IDENTIFIER LOW (ADDRESS: 64h, 74h)

R-x	R-x	R-x	R-x	R-x	R-x	R-x	R-x
EID7	EID6	EID5	EID4	EID3	EID2	EID1	EID0
bit 7							bit 0

bit 7-0 **EID<7:0>**: Extended Identifier Bits <7:0>
 These bits hold the least significant eight bits of the Extended Identifier for the received message

Legend:			
R = Readable bit	W = Writable bit	U = Unimplemented bit, read as '0'	
-n = Value at POR	'1' = Bit is set	'0' = Bit is cleared	x = Bit is unknown

REGISTER 4-8: RXBNDLC - RECEIVE BUFFER N DATA LENGTH CODE (ADDRESS: 65h, 75h)

U-0	R-x	R-x	R-x	R-x	R-x	R-x	R-x
—	RTR	RB1	RB0	DLC3	DLC2	DLC1	DLC0
bit 7							bit 0

bit 7 **Unimplemented**: Reads as '0'
 bit 6 **RTR**: Extended Frame Remote Transmission Request Bit (valid only when RXBnSIDL.IDE = 1)
 1 = Extended Frame Remote Transmit Request Received
 0 = Extended Data Frame Received
 bit 5 **RB1**: Reserved Bit 1
 bit 4 **RB0**: Reserved Bit 0
 bit 3-0 **DLC<3:0>**: Data Length Code
 Indicates number of data bytes that were received

Legend:			
R = Readable bit	W = Writable bit	U = Unimplemented bit, read as '0'	
-n = Value at POR	'1' = Bit is set	'0' = Bit is cleared	x = Bit is unknown

REGISTER 4-9: RXBNDM - RECEIVE BUFFER N DATA FIELD BYTE M (ADDRESS: 66h-6Dh, 76h-7Dh)

R-x	R-x	R-x	R-x	R-x	R-x	R-x	R-x
RBNDm7	RBNDm6	RBNDm5	RBNDm4	RBNDm3	RBNDm2	RBNDm1	RBNDm0
bit 7							bit 0

bit 7-0 **RBNDm7:RBNDm0**: Receive Buffer N Data Field Byte m
 Eight bytes containing the data bytes for the received message

Legend:			
R = Readable bit	W = Writable bit	U = Unimplemented bit, read as '0'	
-n = Value at POR	'1' = Bit is set	'0' = Bit is cleared	x = Bit is unknown

4.5 Message Acceptance Filters and Masks

The Message Acceptance Filters And Masks are used to determine if a message in the message assembly buffer should be loaded into either of the receive buffers (see Figure 4-3). Once a valid message has been received into the MAB, the identifier fields of the message are compared to the filter values. If there is a match, that message will be loaded into the appropriate receive buffer. The filter masks (see Register 4-10 through Register 4-17) are used to determine which bits in the identifier are examined with the filters. A truth table is shown below in Table 4-1 that indicates how each bit in the identifier is compared to the masks and filters to determine if a message should be loaded into a receive buffer. The mask essentially determines which bits to apply the acceptance filters to. If any mask bit is set to a zero, then that bit will automatically be accepted regardless of the filter bit.

TABLE 4-1: FILTER/MASK TRUTH TABLE

Mask Bit n	Filter Bit n	Message Identifier bit n001	Accept or reject bit n
0	X	X	Accept
1	0	0	Accept
1	0	1	Reject
1	1	0	Reject
1	1	1	Accept

Note: X = don't care

As shown in the Receive Buffers Block Diagram (Figure 4-1), acceptance filters RXF0 and RXF1, and filter mask RXM0 are associated with RXB0. Filters RXF2, RXF3, RXF4, and RXF5 and mask RXM1 are associated with RXB1. When a filter matches and a message is loaded into the receive buffer, the filter number that enabled the message reception is loaded into the RXBNCTRL register FILHIT bit(s). For RXB1 the RXB1CTRL register contains the FILHIT<2:0> bits. They are coded as follows:

- 101 = Acceptance Filter 5 (RXF5)
- 100 = Acceptance Filter 4 (RXF4)
- 011 = Acceptance Filter 3 (RXF3)
- 010 = Acceptance Filter 2 (RXF2)
- 001 = Acceptance Filter 1 (RXF1)
- 000 = Acceptance Filter 0 (RXF0)

Note: 000 and 001 can only occur if the BUKT bit (see Table 4-1) is set in the RXB0CTRL register allowing RXB0 messages to roll over into RXB1.

RXB0CTRL contains two copies of the BUKT bit and the FILHIT<0> bit.

The coding of the BUKT bit enables these three bits to be used similarly to the RXB1CTRL.FILHIT bits and to distinguish a hit on filter RXF0 and RXF1 in either RXB0 or after a roll over into RXB1.

- 111 = Acceptance Filter 1 (RXF1)
- 110 = Acceptance Filter 0 (RXF0)
- 001 = Acceptance Filter 1 (RXF1)
- 000 = Acceptance Filter 0

If the BUKT bit is clear, there are six codes corresponding to the six filters. If the BUKT bit is set, there are six codes corresponding to the six filters plus two additional codes corresponding to RXF0 and RXF1 filters that roll over into RXB1.

If more than one acceptance filter matches, the FILHIT bits will encode the binary value of the lowest numbered filter that matched. In other words, if filter RXF2 and filter RXF4 match, FILHIT will be loaded with the value for RXF2. This essentially prioritizes the acceptance filters with a lower number filter having higher priority. Messages are compared to filters in ascending order of filter number.

The mask and filter registers can only be modified when the MCP2510 is in configuration mode (see Section 9.0).

MCP2510

FIGURE 4-3: MESSAGE ACCEPTANCE MASK AND FILTER OPERATION

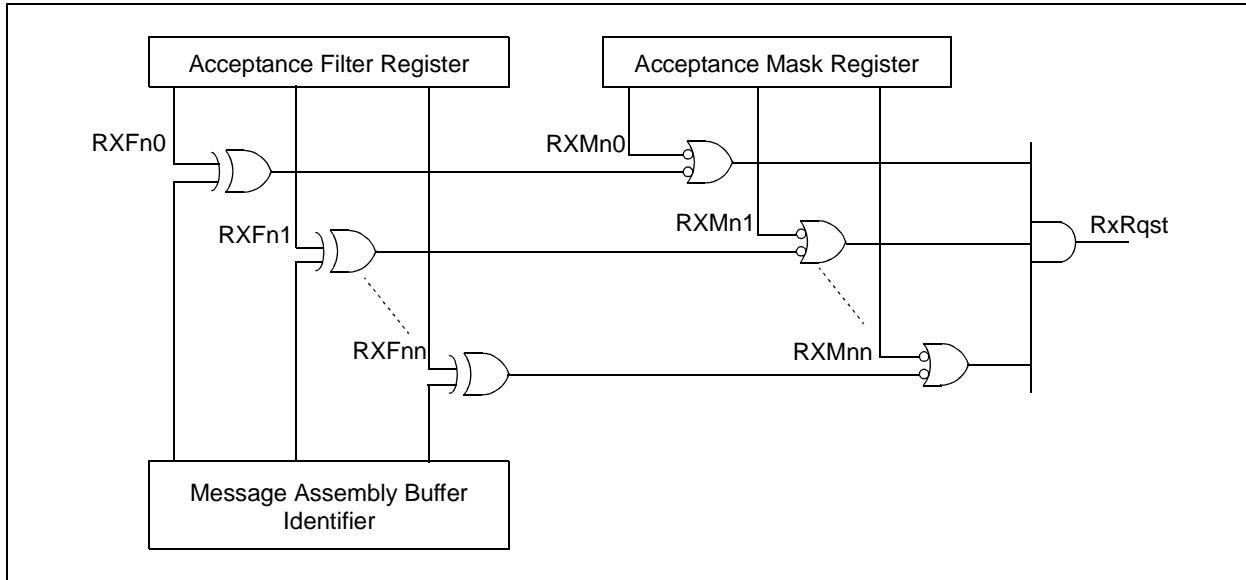

REGISTER 4-10: RXFN SIDH - ACCEPTANCE FILTER N STANDARD IDENTIFIER HIGH (ADDRESS: 00h, 04h, 08h, 10h, 14h, 18h)

R/W-x	R/W-x	R/W-x	R/W-x	R/W-x	R/W-x	R/W-x	R/W-x
SID10	SID9	SID8	SID7	SID6	SID5	SID4	SID3
bit 7						bit 0	

bit 7-0 **SID<10:3>**: Standard Identifier Filter Bits <10:3>

These bits hold the filter bits to be applied to bits <10:3> of the Standard Identifier portion of a received message

Legend:

R = Readable bit W = Writable bit U = Unimplemented bit, read as '0'
 -n = Value at POR '1' = Bit is set '0' = Bit is cleared x = Bit is unknown

**REGISTER 4-11: RXFN SIDL - ACCEPTANCE FILTER N STANDARD IDENTIFIER LOW
(ADDRESS: 01h, 05h, 09h, 11h, 15h, 19h)**

R/W-x	R/W-x	R/W-x	U-0	R/W-x	U-0	R/W-x	R/W-x
SID2	SID1	SID0	—	EXIDE	—	EID17	EID16
						bit 0	
bit 7							

- bit 7-5 **SID<2:0>**: Standard Identifier Filter Bits <2:0>
These bits hold the filter bits to be applied to bits <2:0> of the Standard Identifier portion of a received message
- bit 4 **Unimplemented**: Reads as '0'
- bit 3 **EXIDE**: Extended Identifier Enable
1 = Filter is applied only to Extended Frames
0 = Filter is applied only to Standard Frames
- bit 2 **Unimplemented**: Reads as '0'
- bit 1-0 **EID<17:16>**: Extended Identifier Filter Bits <17:16>
These bits hold the filter bits to be applied to bits <17:16> of the Extended Identifier portion of a received message

Legend:			
R = Readable bit	W = Writable bit	U = Unimplemented bit, read as '0'	
-n = Value at POR	'1' = Bit is set	'0' = Bit is cleared	x = Bit is unknown

**REGISTER 4-12: RXFN EID8 - ACCEPTANCE FILTER N EXTENDED IDENTIFIER HIGH
(ADDRESS: 02h, 06h, 0Ah, 12h, 16h, 1Ah)**

R/W-x	R/W-x	R/W-x	R/W-x	R/W-x	R/W-x	R/W-x	R/W-x
EID15	EID14	EID13	EID12	EID11	EID10	EID9	EID8
						bit 0	
bit 7							

- bit 7-0 **EID<15:8>**: Extended Identifier Bits <15:8>
These bits hold the filter bits to be applied to bits <15:8> of the Extended Identifier portion of a received message

Legend:			
R = Readable bit	W = Writable bit	U = Unimplemented bit, read as '0'	
-n = Value at POR	'1' = Bit is set	'0' = Bit is cleared	x = Bit is unknown

MCP2510

REGISTER 4-13: RXFNEID0 - ACCEPTANCE FILTER N EXTENDED IDENTIFIER LOW (ADDRESS: 03h, 07h, 0Bh, 13h, 17h, 1Bh)

R/W-x	R/W-x	R/W-x	R/W-x	R/W-x	R/W-x	R/W-x	R/W-x
EID7	EID6	EID5	EID4	EID3	EID2	EID1	EID0
bit 7							bit 0

bit 7-0 **EID<7:0>**: Extended Identifier Bits <7:0>
 These bits hold the filter bits to be applied to the bits <7:0> of the Extended Identifier portion of a received message

Legend:			
R = Readable bit	W = Writable bit	U = Unimplemented bit, read as '0'	
-n = Value at POR	'1' = Bit is set	'0' = Bit is cleared	x = Bit is unknown

REGISTER 4-14: RXMNSIDH - ACCEPTANCE FILTER MASK N STANDARD IDENTIFIER HIGH (ADDRESS: 20h, 24h)

R/W-x	R/W-x	R/W-x	R/W-x	R/W-x	R/W-x	R/W-x	R/W-x
SID10	SID9	SID8	SID7	SID6	SID5	SID4	SID3
bit 7							bit 0

bit 7-0 **SID<10:3>**: Standard Identifier Mask Bits <10:3>
 These bits hold the mask bits to be applied to bits <10:3> of the Standard Identifier portion of a received message

Legend:			
R = Readable bit	W = Writable bit	U = Unimplemented bit, read as '0'	
-n = Value at POR	'1' = Bit is set	'0' = Bit is cleared	x = Bit is unknown

REGISTER 4-15: RXMNSIDL - ACCEPTANCE FILTER MASK N STANDARD IDENTIFIER LOW (ADDRESS: 21h, 25h)

R/W-x	R/W-x	R/W-x	U-0	U-0	U-0	R/W-x	R/W-x
SID2	SID1	SID0	—	—	—	EID17	EID16
bit 7							bit 0

bit 7-5 **SID<2:0>**: Standard Identifier Mask Bits <2:0>
 These bits hold the mask bits to be applied to bits<2:0> of the Standard Identifier portion of a received message

bit 4-2 **Unimplemented**: Reads as '0'

bit 1-0 **EID<17:16>**: Extended Identifier Mask Bits <17:16>
 These bits hold the mask bits to be applied to bits <17:16> of the Extended Identifier portion of a received message

Legend:			
R = Readable bit	W = Writable bit	U = Unimplemented bit, read as '0'	
-n = Value at POR	'1' = Bit is set	'0' = Bit is cleared	x = Bit is unknown

**REGISTER 4-16: RXMnEID8 - ACCEPTANCE FILTER MASK N EXTENDED IDENTIFIER HIGH
(ADDRESS: 22h, 26h)**

R/W-x	R/W-x	R/W-x	R/W-x	R/W-x	R/W-x	R/W-x	R/W-x
EID15	EID14	EID13	EID12	EID11	EID10	EID9	EID8
bit 7							bit 0

bit 7-0 **EID<15:8>**: Extended Identifier Bits <15:8>
 These bits hold the filter bits to be applied to bits <15:8> of the Extended Identifier portion of a received message

Legend:			
R = Readable bit	W = Writable bit	U = Unimplemented bit, read as '0'	
-n = Value at POR	'1' = Bit is set	'0' = Bit is cleared	x = Bit is unknown

**REGISTER 4-17: RXMnEID0 - ACCEPTANCE FILTER MASK N EXTENDED IDENTIFIER LOW
(ADDRESS: 23h, 27h)**

R/W-x	R/W-x	R/W-x	R/W-x	R/W-x	R/W-x	R/W-x	R/W-x
EID7	EID6	EID5	EID4	EID3	EID2	EID1	EID0
bit 7							bit 0

bit 7-0 **EID<7:0>**: Extended Identifier Mask Bits <7:0>
 These bits hold the mask bits to be applied to the bits <7:0> of the Extended Identifier portion of a received message

Legend:			
R = Readable bit	W = Writable bit	U = Unimplemented bit, read as '0'	
-n = Value at POR	'1' = Bit is set	'0' = Bit is cleared	x = Bit is unknown

MCP2510

NOTES:

5.0 BIT TIMING

All nodes on a given CAN bus must have the same nominal bit rate. The CAN protocol uses Non Return to Zero (NRZ) coding which does not encode a clock within the data stream. Therefore, the receive clock must be recovered by the receiving nodes and synchronized to the transmitters clock.

As oscillators and transmission time may vary from node to node, the receiver must have some type of Phase Lock Loop (PLL) synchronized to data transmission edges to synchronize and maintain the receiver clock. Since the data is NRZ coded, it is necessary to include bit stuffing to ensure that an edge occurs at least every six bit times, to maintain the Digital Phase Lock Loop (DPLL) synchronization.

The bit timing of the MCP2510 is implemented using a DPLL that is configured to synchronize to the incoming data, and provide the nominal timing for the transmitted data. The DPLL breaks each bit time into multiple segments made up of minimal periods of time called the time quanta (T_Q).

Bus timing functions executed within the bit time frame, such as synchronization to the local oscillator, network transmission delay compensation, and sample point positioning, are defined by the programmable bit timing logic of the DPLL.

All devices on the CAN bus must use the same bit rate. However, all devices are not required to have the same master oscillator clock frequency. For the different clock frequencies of the individual devices, the bit rate has to be adjusted by appropriately setting the baud rate prescaler and number of time quanta in each segment.

The nominal bit rate is the number of bits transmitted per second assuming an ideal transmitter with an ideal oscillator, in the absence of resynchronization. The nominal bit rate is defined to be a maximum of 1 Mb/s.

Nominal Bit Time is defined as:

$$T_{BIT} = 1 / \text{NOMINAL BIT RATE}$$

The nominal bit time can be thought of as being divided into separate non-overlapping time segments. These segments are shown in Figure 5-1.

- Synchronization Segment (Sync_Seg)
- Propagation Time Segment (Prop_Seg)
- Phase Buffer Segment 1 (Phase_Seg1)
- Phase Buffer Segment 2 (Phase_Seg2)

$$\text{Nominal Bit Time} = T_Q * (\text{Sync_Seg} + \text{Prop_Seg} + \text{Phase_Seg1} + \text{Phase_Seg2})$$

The time segments and also the nominal bit time are made up of integer units of time called time quanta or T_Q (see Figure 5-1). By definition, the nominal bit time is programmable from a minimum of 8 T_Q to a maximum of 25 T_Q. Also, by definition the minimum nominal bit time is 1 μs, corresponding to a maximum 1 Mb/s rate.

FIGURE 5-1: BIT TIME PARTITIONING

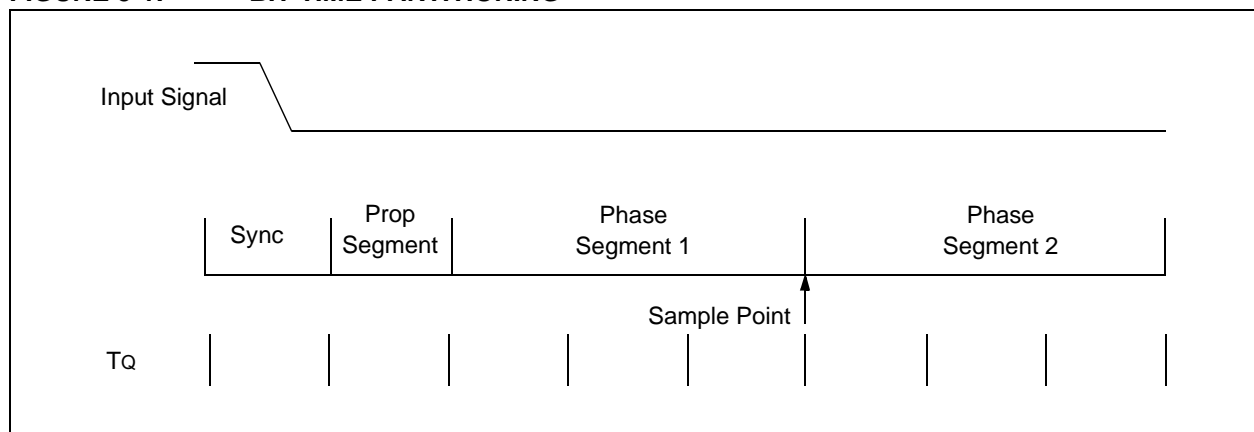

MCP2510

5.1 Time Quanta

The Time Quanta (T_Q) is a fixed unit of time derived from the oscillator period. There is a programmable baud-rate prescaler, with integral values ranging from 1 to 64, in addition to a fixed divide by two for clock generation.

Time quanta is defined as:

$$T_Q = 2 * (\text{Baud Rate} + 1) * T_{OSC}$$

where Baud Rate is the binary value represented by CNF1.BRP<5:0>

For some examples:

If F_{OSC} = 16 MHz, BRP<5:0> = 00h, and Nominal Bit Time = 8 T_Q;

then T_Q = 125 nsec and Nominal Bit Rate = 1 Mb/s

If F_{OSC} = 20 MHz, BRP<5:0> = 01h, and Nominal Bit Time = 8 T_Q;

then T_Q = 200 nsec and Nominal Bit Rate = 625 Kb/s

If F_{OSC} = 25 MHz, BRP<5:0> = 3Fh, and Nominal Bit Time = 25 T_Q;

then T_Q = 5.12 μsec and Nominal Bit Rate = 7.8 Kb/s

The frequencies of the oscillators in the different nodes must be coordinated in order to provide a system-wide specified nominal bit time. This means that all oscillators must have a T_{OSC} that is an integral divisor of T_Q. It should also be noted that although the number of T_Q is programmable from 4 to 25, the usable minimum is 6 T_Q. Attempting to a bit time of less than 6 T_Q in length is not guaranteed to operate correctly

5.2 Synchronization Segment

This part of the bit time is used to synchronize the various CAN nodes on the bus. The edge of the input signal is expected to occur during the sync segment. The duration is 1 T_Q.

5.3 Propagation Segment

This part of the bit time is used to compensate for physical delay times within the network. These delay times consist of the signal propagation time on the bus line and the internal delay time of the nodes. The delay is calculated as being the round trip time from transmitter to receiver (twice the signal's propagation time on the bus line), the input comparator delay, and the output driver delay. The length of the Propagation Segment can be programmed from 1 T_Q to 8 T_Q by setting the PRSEG2:PRSEG0 bits of the CNF2 register (Register 5-2).

The total delay is calculated from the following individual delays:

- 2 * physical bus end to end delay; T_{BUS}
- 2 * input comparator delay; T_{COMP} (depends on application circuit)
- 2 * output driver delay; T_{DRIVE} (depends on application circuit)
- 1 * input to output of CAN controller; T_{CAN} (maximum defined as 1 T_Q + delay ns)
- T_{PROPAGATION} = 2 * (T_{BUS} + T_{COMP} + T_{DRIVE}) + T_{CAN}
- Prop_Seg = T_{PROPAGATION} / T_Q

5.4 Phase Buffer Segments

The Phase Buffer Segments are used to optimally locate the sampling point of the received bit within the nominal bit time. The sampling point occurs between phase segment 1 and phase segment 2. These segments can be lengthened or shortened by the resynchronization process (see Section 5.7.2). Thus, the variation of the values of the phase buffer segments represent the DPLL functionality. The end of phase segment 1 determines the sampling point within a bit time. phase segment 1 is programmable from 1 T_Q to 8 T_Q in duration. Phase segment 2 provides delay before the next transmitted data transition and is also programmable from 1 T_Q to 8 T_Q in duration (however due to IPT requirements the actual minimum length of phase segment 2 is 2 T_Q - see Section 5.6 below), or it may be defined to be equal to the greater of phase segment 1 or the Information Processing Time (IPT). (see Section 5.6).

5.5 Sample Point

The Sample Point is the point of time at which the bus level is read and value of the received bit is determined. The Sampling point occurs at the end of phase segment 1. If the bit timing is slow and contains many T_Q, it is possible to specify multiple sampling of the bus line at the sample point. The value of the received bit is determined to be the value of the majority decision of three values. The three samples are taken at the sample point, and twice before with a time of T_Q/2 between each sample.

5.6 Information Processing Time

The Information Processing Time (IPT) is the time segment, starting at the sample point, that is reserved for calculation of the subsequent bit level. The CAN specification defines this time to be less than or equal to 2 T_Q. The MCP2510 defines this time to be 2 T_Q. Thus, phase segment 2 must be at least 2 T_Q long.

5.7 Synchronization

To compensate for phase shifts between the oscillator frequencies of each of the nodes on the bus, each CAN controller must be able to synchronize to the relevant signal edge of the incoming signal. Synchronization is the process by which the DPLL function is implemented. When an edge in the transmitted data is detected, the logic will compare the location of the edge to the expected time (Sync Seg). The circuit will then adjust the values of phase segment 1 and phase segment 2 as necessary. There are two mechanisms used for synchronization.

5.7.1 HARD SYNCHRONIZATION

Hard Synchronization is only done when there is a recessive to dominant edge during a BUS IDLE condition, indicating the start of a message. After hard synchronization, the bit time counters are restarted with Sync Seg. Hard synchronization forces the edge which has occurred to lie within the synchronization segment of the restarted bit time. Due to the rules of synchronization, if a hard synchronization occurs there will not be a resynchronization within that bit time.

5.7.2 RESYNCHRONIZATION

As a result of Resynchronization, phase segment 1 may be lengthened or phase segment 2 may be shortened. The amount of lengthening or shortening of the phase buffer segments has an upper bound given by the Synchronization Jump Width (SJW). The value of the SJW will be added to phase segment 1 (see Figure 5-2) or subtracted from phase segment 2 (see Figure 5-3). The SJW represents the loop filtering of the DPLL. The SJW is programmable between 1 T_Q and 4 T_Q.

Clocking information will only be derived from recessive to dominant transitions. The property that only a fixed maximum number of successive bits have the same value ensures resynchronization to the bit stream during a frame.

The phase error of an edge is given by the position of the edge relative to Sync Seg, measured in T_Q. The phase error is defined in magnitude of T_Q as follows:

- $e = 0$ if the edge lies within SYNCSEGE
- $e > 0$ if the edge lies before the SAMPLE POINT
- $e < 0$ if the edge lies after the SAMPLE POINT of the previous bit

If the magnitude of the phase error is less than or equal to the programmed value of the synchronization jump width, the effect of a resynchronization is the same as that of a hard synchronization.

If the magnitude of the phase error is larger than the synchronization jump width, and if the phase error is positive, then phase segment 1 is lengthened by an amount equal to the synchronization jump width.

If the magnitude of the phase error is larger than the resynchronization jump width, and if the phase error is negative, then phase segment 2 is shortened by an amount equal to the synchronization jump width.

5.7.3 SYNCHRONIZATION RULES

- Only one synchronization within one bit time is allowed
- An edge will be used for synchronization only if the value detected at the previous sample point (previously read bus value) differs from the bus value immediately after the edge
- All other recessive to dominant edges fulfilling rules 1 and 2 will be used for resynchronization with the exception that a node transmitting a dominant bit will not perform a resynchronization as a result of a recessive to dominant edge with a positive phase error

FIGURE 5-2: LENGTHENING A BIT PERIOD

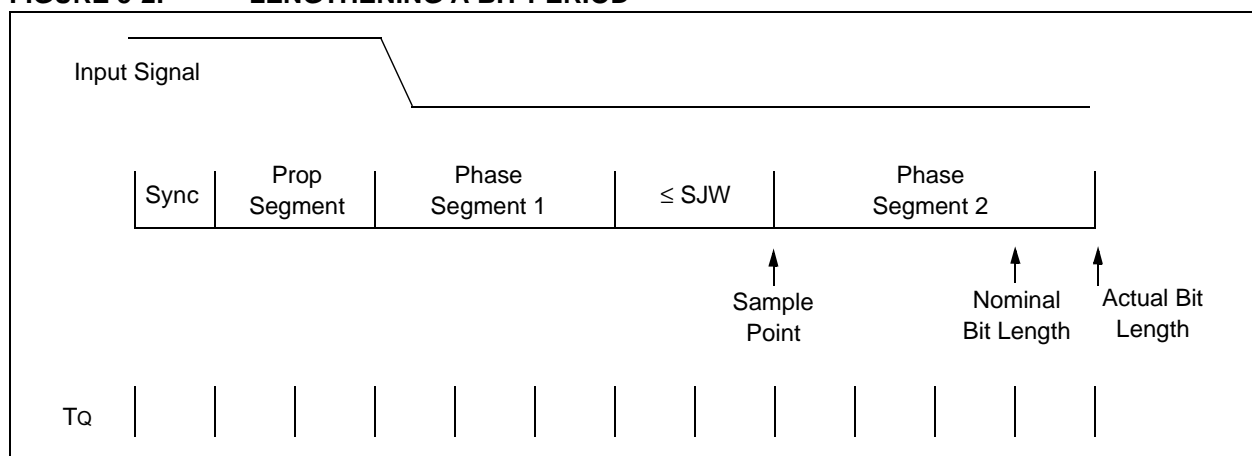

MCP2510

FIGURE 5-3: SHORTENING A BIT PERIOD

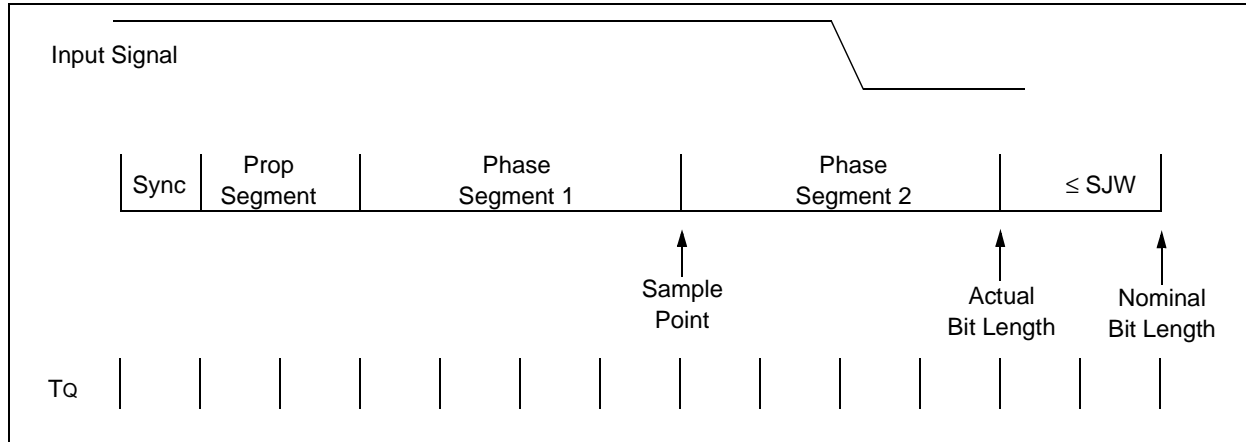

5.8 Programming Time Segments

Some requirements for programming of the time segments:

- Prop Seg + Phase Seg 1 \geq Phase Seg 2
- Prop Seg + Phase Seg 1 \geq TDELAY
- Phase Seg 2 $>$ Sync Jump Width

For example, assuming that a 125 kHz CAN baud rate with FOSC = 20 MHz is desired:

TOSC = 50 nsec, choose BRP<5:0> = 04h, then TQ = 500 nsec. To obtain 125 kHz, the bit time must be 16 TQ.

Typically, the sampling of the bit should take place at about 60-70% of the bit time, depending on the system parameters. Also, typically, the TDELAY is 1-2 TQ.

Sync Seg = 1 TQ; Prop Seg = 2 TQ; So setting Phase Seg 1 = 7 TQ would place the sample at 10 TQ after the transition. This would leave 6 TQ for Phase Seg 2.

Since Phase Seg 2 is 6, by the rules, SJW could be the maximum of 4 TQ. However, normally a large SJW is only necessary when the clock generation of the different nodes is inaccurate or unstable, such as using ceramic resonators. So an SJW of 1 is typically enough.

5.9 Oscillator Tolerance

The bit timing requirements allow ceramic resonators to be used in applications with transmission rates of up to 125 kbit/sec, as a rule of thumb. For the full bus speed range of the CAN protocol, a quartz oscillator is required. A maximum node-to-node oscillator variation of 1.7% is allowed.

5.10 Bit Timing Configuration Registers

The configuration registers (CNF1, CNF2, CNF3) control the bit timing for the CAN bus interface. These registers can only be modified when the MCP2510 is in configuration mode (see Section 9.0).

5.10.1 CNF1

The BRP<5:0> bits control the baud rate prescaler. These bits set the length of T_Q relative to the OSC1 input frequency, with the minimum length of T_Q being 2 OSC1 clock cycles in length (when BRP<5:0> are set to 000000). The SJW<1:0> bits select the synchronization jump width in terms of number of T_Q's.

5.10.2 CNF2

The PRSEG<2:0> bits set the length, in T_Q's, of the propagation segment. The PHSEG1<2:0> bits set the length, in T_Q's, of phase segment 1. The SAM bit controls how many times the RXCAN pin is sampled. Setting this bit to a '1' causes the bus to be sampled three times; twice at T_Q/2 before the sample point, and once at the normal sample point (which is at the end of phase segment 1). The value of the bus is determined to be the value read during at least two of the samples. If the SAM bit is set to a '0' then the RXCAN pin is sampled only once at the sample point. The BTLMODE bit controls how the length of phase segment 2 is determined. If this bit is set to a '1' then the length of phase segment 2 is determined by the PHSEG2<2:0> bits of CNF3 (see Section 5.10.3). If the BTLMODE bit is set to a '0' then the length of phase segment 2 is the greater of phase segment 1 and the information processing time (which is fixed at 2 T_Q for the MCP2510).

ting this bit to a '1' causes the bus to be sampled three times; twice at T_Q/2 before the sample point, and once at the normal sample point (which is at the end of phase segment 1). The value of the bus is determined to be the value read during at least two of the samples. If the SAM bit is set to a '0' then the RXCAN pin is sampled only once at the sample point. The BTLMODE bit controls how the length of phase segment 2 is determined. If this bit is set to a '1' then the length of phase segment 2 is determined by the PHSEG2<2:0> bits of CNF3 (see Section 5.10.3). If the BTLMODE bit is set to a '0' then the length of phase segment 2 is the greater of phase segment 1 and the information processing time (which is fixed at 2 T_Q for the MCP2510).

5.10.3 CNF3

The PHSEG2<2:0> bits set the length, in T_Q's, of Phase Segment 2, if the CNF2.BTLMODE bit is set to a '1'. If the BTLMODE bit is set to a '0' then the PHSEG2<2:0> bits have no effect.

REGISTER 5-1: CNF1 - CONFIGURATION REGISTER1 (ADDRESS: 2Ah)

R/W-0	R/W-0	R/W-0	R/W-0	R/W-0	R/W-0	R/W-0	R/W-0
SJW1	SJW0	BRP5	BRP4	BRP3	BRP2	BRP1	BRP0
bit 7							bit 0

bit 7-6 **SJW<1:0>**: Synchronization Jump Width Length

11 = Length = 4 x T_Q
 10 = Length = 3 x T_Q
 01 = Length = 2 x T_Q
 00 = Length = 1 x T_Q

bit 5-0 **BRP<5:0>**: Baud Rate Prescaler

$T_Q = 2 \times (BRP + 1) / F_{osc}$

Legend:

R = Readable bit	W = Writable bit	U = Unimplemented bit, read as '0'
-n = Value at POR	'1' = Bit is set	'0' = Bit is cleared x = Bit is unknown

MCP2510

REGISTER 5-2: CNF2 - CONFIGURATION REGISTER2 (ADDRESS: 29h)

R/W-0	R/W-0	R/W-0	R/W-0	R/W-0	R/W-0	R/W-0	R/W-0	
BTLMODE	SAM	PHSEG12	PHSEG11	PHSEG10	PRSEG2	PRSEG1	PRSEG0	
bit 7								bit 0

- bit 7 **BTLMODE:** Phase Segment 2 Bit Time Length
 1 = Length of Phase Seg 2 determined by PHSEG22:PHSEG20 bits of CNF3
 0 = Length of Phase Seg 2 is the greater of Phase Seg 1 and IPT (2T_Q)
- bit 6 **SAM:** Sample Point Configuration
 1 = Bus line is sampled three times at the sample point
 0 = Bus line is sampled once at the sample point
- bit 5-3 **PHSEG1<2:0>:** Phase Segment 1 Length
 (PHSEG1 + 1) x T_Q
- bit 2-0 **PRSEG<2:0>:** Propagation Segment Length
 (PRSEG + 1) x T_Q

Legend:			
R = Readable bit	W = Writable bit	U = Unimplemented bit, read as '0'	
-n = Value at POR	'1' = Bit is set	'0' = Bit is cleared	x = Bit is unknown

REGISTER 5-3: CNF3 - CONFIGURATION REGISTER 3 (ADDRESS: 28h)

U-0	R/W-0	U-0	U-0	U-0	R/W-0	R/W-0	R/W-0
—	WAKFIL	—	—	—	PHSEG22	PHSEG21	PHSEG20
bit 7						bit 0	

- bit 7 **Unimplemented:** Reads as '0'
- bit 6 **WAKFIL:** Wake-up Filter
 1 = Wake-up filter enabled
 0 = Wake-up filter disabled
- bit 5-3 **Unimplemented:** Reads as '0'
- bit 2-0 **PHSEG2<2:0>:** Phase Segment 2 Length
 (PHSEG2 + 1) x T_Q
Note: Minimum valid setting for Phase Segment 2 is 2T_Q

Legend:			
R = Readable bit	W = Writable bit	U = Unimplemented bit, read as '0'	
-n = Value at POR	'1' = Bit is set	'0' = Bit is cleared	x = Bit is unknown

6.0 ERROR DETECTION

The CAN protocol provides sophisticated error detection mechanisms. The following errors can be detected.

6.1 CRC Error

With the Cyclic Redundancy Check (CRC), the transmitter calculates special check bits for the bit sequence from the start of a frame until the end of the data field. This CRC sequence is transmitted in the CRC Field. The receiving node also calculates the CRC sequence using the same formula and performs a comparison to the received sequence. If a mismatch is detected, a CRC error has occurred and an error frame is generated. The message is repeated.

6.2 Acknowledge Error

In the acknowledge field of a message, the transmitter checks if the acknowledge slot (which has sent out as a recessive bit) contains a dominant bit. If not, no other node has received the frame correctly. An acknowledge error has occurred; an error frame is generated; and the message will have to be repeated.

6.3 Form Error

If a node detects a dominant bit in one of the four segments including end of frame, interframe space, acknowledge delimiter or CRC delimiter; then a form error has occurred and an error frame is generated. The message is repeated.

6.4 Bit Error

A Bit Error occurs if a transmitter sends a dominant bit and detects a recessive bit or if it sends a recessive bit and detects a dominant bit when monitoring the actual bus level and comparing it to the just transmitted bit. In the case where the transmitter sends a recessive bit and a dominant bit is detected during the arbitration field and the acknowledge slot, no bit error is generated because normal arbitration is occurring.

6.5 Stuff Error

If, between the start of frame and the CRC delimiter, six consecutive bits with the same polarity are detected, the bit stuffing rule has been violated. A stuff error occurs and an error frame is generated. The message is repeated.

6.6 Error States

Detected errors are made public to all other nodes via error frames. The transmission of the erroneous message is aborted and the frame is repeated as soon as possible. Furthermore, each CAN node is in one of the three error states "error-active", "error-passive" or "bus-off" according to the value of the internal error counters. The error-active state is the usual state where the bus node can transmit messages and active error frames (made of dominant bits) without any restrictions. In the error-passive state, messages and passive error frames (made of recessive bits) may be transmitted. The bus-off state makes it temporarily impossible for the station to participate in the bus communication. During this state, messages can neither be received nor transmitted.

6.7 Error Modes and Error Counters

The MCP2510 contains two error counters: the Receive Error Counter (REC) (see Register 6-2), and the Transmit Error Counter (TEC) (see Register 6-1). The values of both counters can be read by the MCU. These counters are incremented or decremented in accordance with the CAN bus specification.

The MCP2510 is error-active if both error counters are below the error-passive limit of 128. It is error-passive if at least one of the error counters equals or exceeds 128. It goes to bus-off if the transmit error counter equals or exceeds the bus-off limit of 256. The device remains in this state, until the bus-off recovery sequence is received. The bus-off recovery sequence consists of 128 occurrences of 11 consecutive recessive bits (see Figure 6-1). Note that the MCP2510, after going bus-off, will recover back to error-active, without any intervention by the MCU, if the bus remains idle for 128 X 11 bit times. If this is not desired, the error interrupt service routine should address this. The current error mode of the MCP2510 can be read by the MCU via the EFLG register (Register 6-3).

Additionally, there is an error state warning flag bit, EFLG:EWARN, which is set if at least one of the error counters equals or exceeds the error warning limit of 96. EWARN is reset if both error counters are less than the error warning limit.

MCP2510

FIGURE 6-1: ERROR MODES STATE DIAGRAM

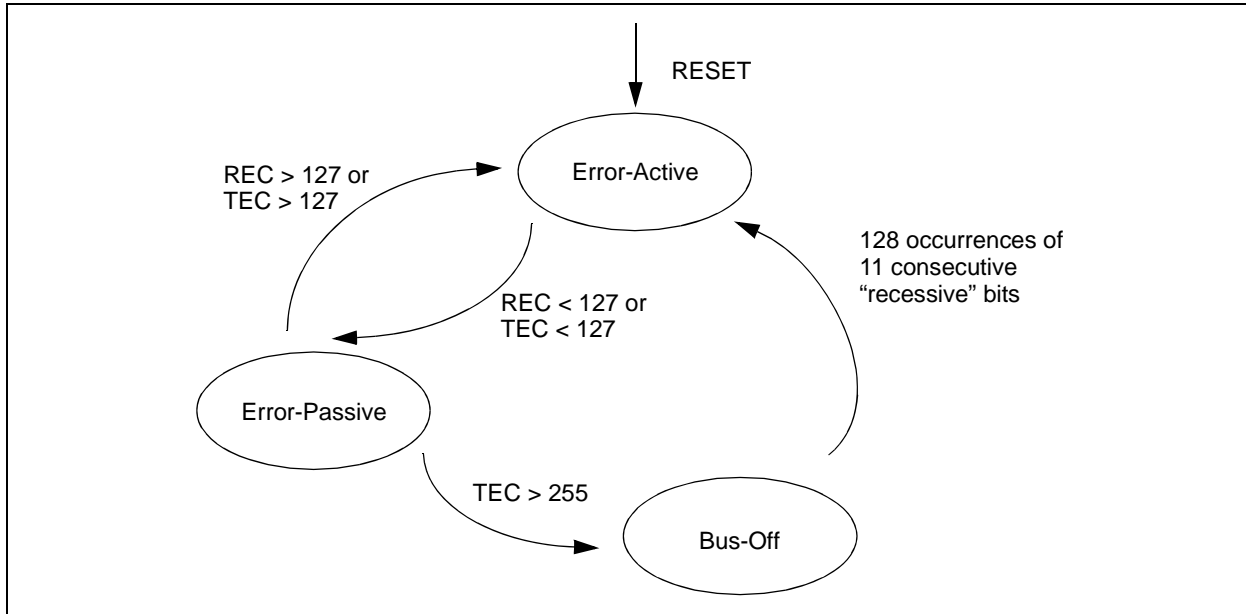

REGISTER 6-1: TEC - TRANSMITTER ERROR COUNTER (ADDRESS: 1Ch)

R-0	R-0	R-0	R-0	R-0	R-0	R-0	R-0	
TEC7	TEC6	TEC5	TEC4	TEC3	TEC2	TEC1	TEC0	
							bit 7	bit 0

bit 7-0 **TEC<7:0>**: Transmit Error Count

Legend:			
R = Readable bit	W = Writable bit	U = Unimplemented bit, read as '0'	
-n = Value at POR	'1' = Bit is set	'0' = Bit is cleared	x = Bit is unknown

REGISTER 6-2: REC - RECEIVER ERROR COUNTER (ADDRESS: 1Dh)

R-0	R-0	R-0	R-0	R-0	R-0	R-0	R-0	
REC7	REC6	REC5	REC4	REC3	REC2	REC1	REC0	
							bit 7	bit 0

bit 7-0 **REC<7:0>**: Receive Error Count

Legend:			
R = Readable bit	W = Writable bit	U = Unimplemented bit, read as '0'	
-n = Value at POR	'1' = Bit is set	'0' = Bit is cleared	x = Bit is unknown

REGISTER 6-3: EFLG - ERROR FLAG REGISTER (ADDRESS: 2Dh)

R/W-0	R/W-0	R-0	R-0	R-0	R-0	R-0	R-0
RX1OVR	RX0OVR	TXBO	TXEP	RXEP	TXWAR	RXWAR	EWARN
bit 7							bit 0

- bit 7 **RX1OVR**: Receive Buffer 1 Overflow Flag
 - Set when a valid message is received for RXB1 and CANINTF.RX1IF = 1
 - Must be reset by MCU
- bit 6 **RX0OVR**: Receive Buffer 0 Overflow Flag
 - Set when a valid message is received for RXB0 and CANINTF.RX0IF = 1
 - Must be reset by MCU
- bit 5 **TXBO**: Bus-Off Error Flag
 - Bit set when TEC reaches 255
 - Reset after a successful bus recovery sequence
- bit 4 **TXEP**: Transmit Error-Passive Flag
 - Set when TEC is equal to or greater than 128
 - Reset when TEC is less than 128
- bit 3 **RXEP**: Receive Error-Passive Flag
 - Set when REC is equal to or greater than 128
 - Reset when REC is less than 128
- bit 2 **TXWAR**: Transmit Error Warning Flag
 - Set when TEC is equal to or greater than 96
 - Reset when TEC is less than 96
- bit 1 **RXWAR**: Receive Error Warning Flag
 - Set when REC is equal to or greater than 96
 - Reset when REC is less than 96
- bit 0 **EWARN**: Error Warning Flag
 - Set when TEC or REC is equal to or greater than 96 (TXWAR or RXWAR = 1)
 - Reset when both REC and TEC are less than 96

Legend:

R = Readable bit	W = Writable bit	U = Unimplemented bit, read as '0'
-n = Value at POR	'1' = Bit is set	'0' = Bit is cleared x = Bit is unknown

MCP2510

NOTES:

7.0 INTERRUPTS

The device has eight sources of interrupts. The CANINTE register contains the individual interrupt enable bits for each interrupt source. The CANINTF register contains the corresponding interrupt flag bit for each interrupt source. When an interrupt occurs the $\overline{\text{INT}}$ pin is driven low by the MCP2510 and will remain low until the Interrupt is cleared by the MCU. An Interrupt can not be cleared if the respective condition still prevails.

It is recommended that the bit modify command be used to reset flag bits in the CANINTF register rather than normal write operations. This is to prevent unintentionally changing a flag that changes during the write command, potentially causing an interrupt to be missed.

It should be noted that the CANINTF flags are read/write and an Interrupt can be generated by the MCU setting any of these bits, provided the associated CANINTE bit is also set.

7.1 Interrupt Code Bits

The source of a pending interrupt is indicated in the CANSTAT.ICOD (interrupt code) bits as indicated in Register 9-2. In the event that multiple interrupts occur, the $\overline{\text{INT}}$ will remain low until all interrupts have been reset by the MCU, and the CANSTAT.ICOD bits will reflect the code for the highest priority interrupt that is currently pending. Interrupts are internally prioritized such that the lower the ICOD value the higher the interrupt priority. Once the highest priority interrupt condition has been cleared, the code for the next highest priority interrupt that is pending (if any) will be reflected by the ICOD bits (see Table 7-1). Note that only those interrupt sources that have their associated CANINTE enable bit set will be reflected in the ICOD bits.

TABLE 7-1: ICOD<2:0> DECODE

ICOD<2:0>	Boolean Expression
000	$\overline{\text{ERR}} \cdot \overline{\text{WAK}} \cdot \overline{\text{TX0}} \cdot \overline{\text{TX1}} \cdot \overline{\text{TX2}} \cdot \overline{\text{RX0}} \cdot \overline{\text{RX1}}$
001	ERR
010	$\overline{\text{ERR}} \cdot \overline{\text{WAK}}$
011	$\overline{\text{ERR}} \cdot \overline{\text{WAK}} \cdot \overline{\text{TX0}}$
100	$\overline{\text{ERR}} \cdot \overline{\text{WAK}} \cdot \overline{\text{TX0}} \cdot \overline{\text{TX1}}$
101	$\overline{\text{ERR}} \cdot \overline{\text{WAK}} \cdot \overline{\text{TX0}} \cdot \overline{\text{TX1}} \cdot \overline{\text{TX2}}$
110	$\overline{\text{ERR}} \cdot \overline{\text{WAK}} \cdot \overline{\text{TX0}} \cdot \overline{\text{TX1}} \cdot \overline{\text{TX2}} \cdot \overline{\text{RX0}}$
111	$\overline{\text{ERR}} \cdot \overline{\text{WAK}} \cdot \overline{\text{TX0}} \cdot \overline{\text{TX1}} \cdot \overline{\text{TX2}} \cdot \overline{\text{RX0}} \cdot \overline{\text{RX1}}$

7.2 Transmit Interrupt

When the Transmit Interrupt is enabled (CANINTE.TXNIE = 1) an Interrupt will be generated on the $\overline{\text{INT}}$ pin when the associated transmit buffer becomes empty and is ready to be loaded with a new message. The CANINTF.TXNIF bit will be set to indicate the source of the interrupt. The interrupt is cleared by the MCU resetting the TXNIF bit to a '0'.

7.3 Receive Interrupt

When the Receive Interrupt is enabled (CANINTE.RXNIE = 1) an interrupt will be generated on the $\overline{\text{INT}}$ pin when a message has been successfully received and loaded into the associated receive buffer. This interrupt is activated immediately after receiving the EOF field. The CANINTF.RXNIF bit will be set to indicate the source of the interrupt. The interrupt is cleared by the MCU resetting the RXNIF bit to a '0'.

7.4 Message Error Interrupt

When an error occurs during transmission or reception of a message the message error flag (CANINTF.MERRF) will be set and, if the CANINTE.MERRE bit is set, an interrupt will be generated on the $\overline{\text{INT}}$ pin. This is intended to be used to facilitate baud rate determination when used in conjunction with listen-only mode.

7.5 Bus Activity Wakeup Interrupt

When the MCP2510 is in sleep mode and the bus activity wakeup interrupt is enabled (CANINTE.WAKIE = 1), an interrupt will be generated on the $\overline{\text{INT}}$ pin, and the CANINTF.WAKIF bit will be set when activity is detected on the CAN bus. This interrupt causes the MCP2510 to exit sleep mode. The interrupt is reset by the MCU clearing the WAKIF bit.

7.6 Error Interrupt

When the error interrupt is enabled ($\text{CANINTE.ERRIE} = 1$) an interrupt is generated on the INT pin if an overflow condition occurs or if the error state of transmitter or receiver has changed. The Error Flag Register (EFLG) will indicate one of the following conditions.

7.6.1 RECEIVER OVERFLOW

An overflow condition occurs when the MAB has assembled a valid received message (the message meets the criteria of the acceptance filters) and the receive buffer associated with the filter is not available for loading of a new message. The associated EFLG.RXNOVR bit will be set to indicate the overflow condition. This bit must be cleared by the MCU.

7.6.2 RECEIVER WARNING

The receive error counter has reached the MCU warning limit of 96.

7.6.3 TRANSMITTER WARNING

The transmit error counter has reached the MCU warning limit of 96.

7.6.4 RECEIVER ERROR-PASSIVE

The receive error counter has exceeded the error-passive limit of 127 and the device has gone to error-passive state.

7.6.5 TRANSMITTER ERROR-PASSIVE

The transmit error counter has exceeded the error-passive limit of 127 and the device has gone to error-passive state.

7.6.6 BUS-OFF

The transmit error counter has exceeded 255 and the device has gone to bus-off state.

7.7 Interrupt Acknowledge

Interrupts are directly associated with one or more status flags in the CANINTF register. Interrupts are pending as long as one of the flags is set. Once an interrupt flag is set by the device, the flag can not be reset by the MCU until the interrupt condition is removed.

REGISTER 7-1: CANINTE - INTERRUPT ENABLE REGISTER (ADDRESS: 2Bh)

R/W-0	R/W-0	R/W-0	R/W-0	R/W-0	R/W-0	R/W-0	R/W-0
MERRE	WAKIE	ERRIE	TX2IE	TX1IE	TX0IE	RX1IE	RX0IE

bit 7

bit 0

- bit 7 **MERRE:** Message Error Interrupt Enable
 1 = Interrupt on error during message reception or transmission
 0 = Disabled
- bit 6 **WAKIE:** Wakeup Interrupt Enable
 1 = Interrupt on CAN bus activity
 0 = Disabled
- bit 5 **ERRIE:** Error Interrupt Enable (multiple sources in EFLG register)
 1 = Interrupt on EFLG error condition change
 0 = Disabled
- bit 4 **TX2IE:** Transmit Buffer 2 Empty Interrupt Enable
 1 = Interrupt on TXB2 becoming empty
 0 = Disabled
- bit 3 **TX1IE:** Transmit Buffer 1 Empty Interrupt Enable
 1 = Interrupt on TXB1 becoming empty
 0 = Disabled
- bit 2 **TX0IE:** Transmit Buffer 0 Empty Interrupt Enable
 1 = Interrupt on TXB0 becoming empty
 0 = Disabled
- bit 1 **RX1IE:** Receive Buffer 1 Full Interrupt Enable
 1 = Interrupt when message received in RXB1
 0 = Disabled
- bit 0 **RX0IE:** Receive Buffer 0 Full Interrupt Enable
 1 = Interrupt when message received in RXB0
 0 = Disabled

Legend:			
R = Readable bit	W = Writable bit	U = Unimplemented bit, read as '0'	
-n = Value at POR	'1' = Bit is set	'0' = Bit is cleared	x = Bit is unknown

MCP2510

REGISTER 7-2: CANINTF - INTERRUPT FLAG REGISTER (ADDRESS: 2Ch)

R/W-0	R/W-0	R/W-0	R/W-0	R/W-0	R/W-0	R/W-0	R/W-0
MERRF	WAKIF	ERRIF	TX2IF	TX1IF	TX0IF	RX1IF	RX0IF

bit 7

bit 0

- bit 7 **MERRF**: Message Error Interrupt Flag
 1 = Interrupt pending (must be cleared by MCU to reset interrupt condition)
 0 = No interrupt pending
- bit 6 **WAKIF**: Wakeup Interrupt Flag
 1 = Interrupt pending (must be cleared by MCU to reset interrupt condition)
 0 = No interrupt pending
- bit 5 **ERRIF**: Error Interrupt Flag (multiple sources in EFLG register)
 1 = Interrupt pending (must be cleared by MCU to reset interrupt condition)
 0 = No interrupt pending
- bit 4 **TX2IF**: Transmit Buffer 2 Empty Interrupt Flag
 1 = Interrupt pending (must be cleared by MCU to reset interrupt condition)
 0 = No interrupt pending
- bit 3 **TX1IF**: Transmit Buffer 1 Empty Interrupt Flag
 1 = Interrupt pending (must be cleared by MCU to reset interrupt condition)
 0 = No interrupt pending
- bit 2 **TX0IF**: Transmit Buffer 0 Empty Interrupt Flag
 1 = Interrupt pending (must be cleared by MCU to reset interrupt condition)
 0 = No interrupt pending
- bit 1 **RX1IF**: Receive Buffer 1 Full Interrupt Flag
 1 = Interrupt pending (must be cleared by MCU to reset interrupt condition)
 0 = No interrupt pending
- bit 0 **RX0IF**: Receive Buffer 0 Full Interrupt Flag
 1 = Interrupt pending (must be cleared by MCU to reset interrupt condition)
 0 = No interrupt pending

Legend:			
R = Readable bit	W = Writable bit	U = Unimplemented bit, read as '0'	
-n = Value at POR	'1' = Bit is set	'0' = Bit is cleared	x = Bit is unknown

8.0 OSCILLATOR

The MCP2510 is designed to be operated with a crystal or ceramic resonator connected to the OSC1 and OSC2 pins. The MCP2510 oscillator design requires the use of a parallel cut crystal. Use of a series cut crystal may give a frequency out of the crystal manufacturers specifications. A typical oscillator circuit is shown in Figure 8-1. The MCP2510 may also be driven by an external clock source connected to the OSC1 pin as shown in Figure 8-2 and Figure 8-3.

8.1 Oscillator Startup Timer

The MCP2510 utilizes an oscillator startup timer (OST), which holds the MCP2510 in reset, to insure that the oscillator has stabilized before the internal state machine begins to operate. The OST maintains reset for the first 128 OSC1 clock cycles after power up, RESET, or wake up from sleep mode occurs. It should be noted that no SPI operations should be attempted until after the OST has expired.

8.2 CLKOUT Pin

The clock out pin is provided to the system designer for use as the main system clock or as a clock input for other devices in the system. The CLKOUT has an internal prescaler which can divide FOSC by 1, 2, 4 and 8. The CLKOUT function is enabled and the prescaler is selected via the CANCECTRL register (see Register 9-1). The CLKOUT pin will be active upon system reset and default to the slowest speed (divide by 8) so that it can be used as the MCU clock. When sleep mode is requested, the MCP2510 will drive sixteen additional clock cycles on the CLKOUT pin before entering sleep mode. The idle state of the CLKOUT pin in sleep mode is low. When the CLKOUT function is disabled (CANCECTRL.CLKEN = '0') the CLKOUT pin is in a high impedance state.

The CLKOUT function is designed to guarantee that $t_{HCLKOUT}$ and $t_{LCLKOUT}$ timings are preserved when the CLKOUT pin function is enabled, disabled, or the prescaler value is changed.

FIGURE 8-1: CRYSTAL/CERAMIC RESONATOR OPERATION

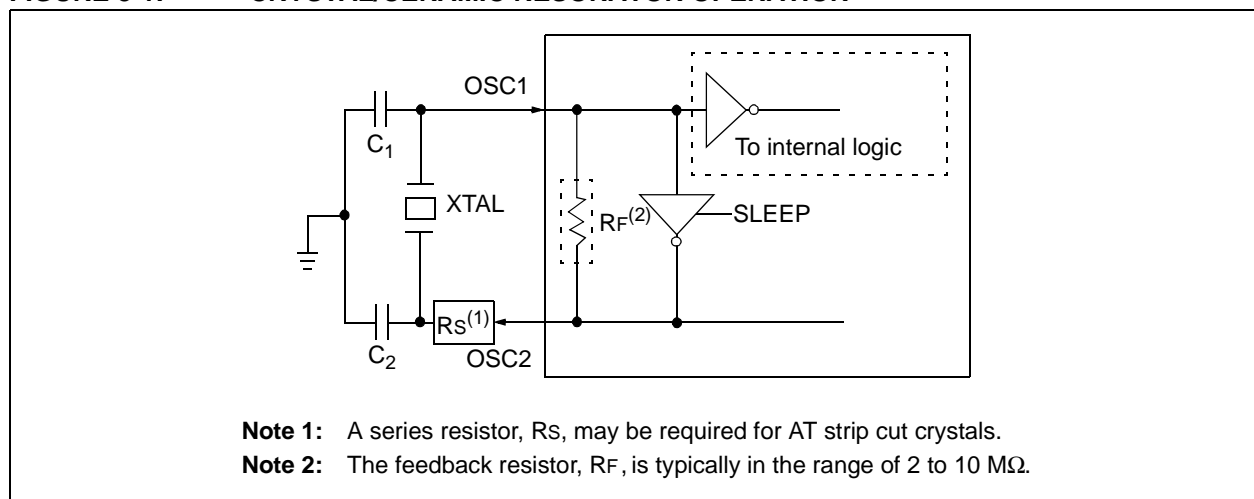
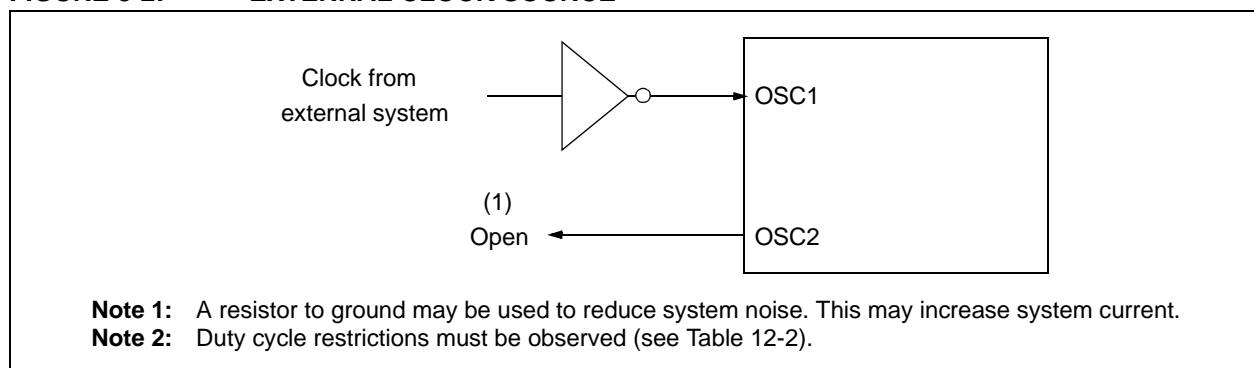
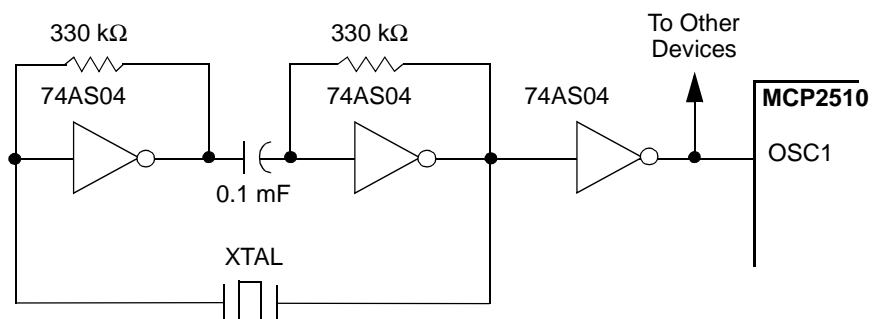

FIGURE 8-2: EXTERNAL CLOCK SOURCE



MCP2510

FIGURE 8-3: EXTERNAL SERIES RESONANT CRYSTAL OSCILLATOR CIRCUIT



Note 1: Duty cycle restrictions must be observed (see Table 12-2).

9.0 MODES OF OPERATION

The MCP2510 has five modes of operation. These modes are:

1. Configuration Mode.
2. Normal Mode.
3. Sleep Mode.
4. Listen-Only Mode.
5. Loopback Mode.

The operational mode is selected via the CANCTRL.REQOP bits (see Register 9-1). When changing modes, the mode will not actually change until all pending message transmissions are complete. Because of this, the user must verify that the device has actually changed into the requested mode before further operations are executed. Verification of the current operating mode is done by reading the CANSTAT.OPMODE bits (see Register 9-2).

9.1 Configuration Mode

The MCP2510 must be initialized before activation. This is only possible if the device is in the configuration mode. Configuration mode is automatically selected after powerup or a reset, or can be entered from any other mode by setting the CANCTRL.REQOP bits to '100'. When configuration mode is entered all error counters are cleared. Configuration mode is the only mode where the following registers are modifiable:

- CNF1, CNF2, CNF3
- TXRTSCTRL
- Acceptance Filter Registers
- Acceptance Mask Registers

Only when the CANSTAT.OPMODE bits read as '100' can the initialization be performed, allowing the configuration registers, acceptance mask registers, and the acceptance filter registers to be written. After the configuration is complete, the device can be activated by programming the CANCTRL.REQOP bits for normal operation mode (or any other mode).

9.2 Sleep Mode

The MCP2510 has an internal sleep mode that is used to minimize the current consumption of the device. The SPI interface remains active even when the MCP2510 is in sleep mode, allowing access to all registers.

To enter sleep mode, the mode request bits are set in the CANCTRL register. The CANSTAT.OPMODE bits indicate whether the device successfully entered sleep mode. These bits should be read after sending the sleep command to the MCP2510. The MCP2510 is active and has not yet entered sleep mode until these bits indicate that sleep mode has been entered. When in internal sleep mode, the wakeup interrupt is still active (if enabled). This is done so the MCU can also

be placed into a sleep mode and use the MCP2510 to wake it up upon detecting activity on the bus.

Note: Care must be exercised to not enter sleep mode while the MCP2510 is transmitting a message. If sleep mode is requested while transmitting, the transmission will stop without completing and errors will occur on the bus. Also, the message will remain pending and transmit upon wake up.

When in sleep mode, the MCP2510 stops its internal oscillator. The MCP2510 will wake-up when bus activity occurs or when the MCU sets, via the SPI interface, the CANINTF.WAKIF bit to 'generate' a wake up attempt (the CANINTF.WAKIF bit must also be set in order for the wakeup interrupt to occur). The TXCAN pin will remain in the recessive state while the MCP2510 is in sleep mode. Note that Sleep Mode will be entered immediately, even if a message is currently being transmitted, so it is necessary to insure that all TXREQ bits are clear before setting Sleep Mode.

9.2.1 WAKE-UP FUNCTIONS

The device will monitor the RXCAN pin for activity while it is in sleep mode. If the CANINTE.WAKIE bit is set, the device will wake up and generate an interrupt. Since the internal oscillator is shut down when sleep mode is entered, it will take some amount of time for the oscillator to start up and the device to enable itself to receive messages. The device will ignore the message that caused the wake-up from sleep mode as well as any messages that occur while the device is 'waking up.' The device will wake up in listen-only mode. The MCU must set normal mode before the MCP2510 will be able to communicate on the bus.

The device can be programmed to apply a low-pass filter function to the RXCAN input line while in internal sleep mode. This feature can be used to prevent the device from waking up due to short glitches on the CAN bus lines. The CNF3.WAKFIL bit enables or disables the filter.

9.3 Listen Only Mode

Listen-only mode provides a means for the MCP2510 to receive all messages including messages with errors. This mode can be used for bus monitor applications or for detecting the baud rate in 'hot plugging' situations. For auto-baud detection it is necessary that there are at least two other nodes, which are communicating with each other. The baud rate can be detected empirically by testing different values until valid messages are received. The listen-only mode is a silent mode, meaning no messages will be transmitted while in this state, including error flags or acknowledge signals. The filters and masks can be used to allow only particular messages to be loaded into the receive registers, or the filter masks can be set to all zeros to allow a message with any identifier to pass. The error

MCP2510

counters are reset and deactivated in this state. The listen-only mode is activated by setting the mode request bits in the CANCTRL register.

9.4 Loopback Mode

This mode will allow internal transmission of messages from the transmit buffers to the receive buffers without actually transmitting messages on the CAN bus. This mode can be used in system development and testing. In this mode the ACK bit is ignored and the device will allow incoming messages from itself just as if they were coming from another node. The loopback mode is a silent mode, meaning no messages will be transmitted while in this state, including error flags or acknowledge signals. The TXCAN pin will be in a recessive state while the device is in this mode. The filters and masks can be used to allow only particular messages to be loaded into the receive registers. The masks can be set to all zeros to provide a mode that accepts all messages. The loopback mode is activated by setting the mode request bits in the CANCTRL register.

9.5 Normal Mode

This is the standard operating mode of the MCP2510. In this mode the device actively monitors all bus messages and generates acknowledge bits, error frames, etc. This is also the only mode in which the MCP2510 will transmit messages over the CAN bus.

REGISTER 9-1: CANCTRL - CAN CONTROL REGISTER (ADDRESS: XFh)

R/W-1	R/W-1	R/W-1	R/W-0	U-0	R/W-1	R/W-1	R/W-1
REQOP2	REQOP1	REQOP0	ABAT	—	CLKEN	CLKPRE1	CLKPRE0
						bit 0	
							bit 7

- bit 7-5 **REQOP<2:0>**: Request Operation Mode
 - 000 = Set Normal Operation Mode
 - 001 = Set Sleep Mode
 - 010 = Set Loopback Mode
 - 011 = Set Listen Only Mode
 - 100 = Set Configuration Mode

All other values for REQOP bits are invalid and should not be used

Note: On power up, REQOP = b'111'
- bit 4 **ABAT**: Abort All Pending Transmissions
 - 1 = Request abort of all pending transmit buffers
 - 0 = Terminate request to abort all transmissions
- bit 3 **Unimplemented**: Read as '0'
- bit 2 **CLKEN**: CLKOUT Pin Enable
 - 1 = CLKOUT pin enabled
 - 0 = CLKOUT pin disabled (Pin is in high impedance state)
- bit 1-0 **CLKPRE <1:0>**: CLKOUT Pin Prescaler
 - 00 = FCLKOUT = System Clock/1
 - 01 = FCLKOUT = System Clock/2
 - 10 = FCLKOUT = System Clock/4
 - 11 = FCLKOUT = System Clock/8

Legend:			
R = Readable bit	W = Writable bit	U = Unimplemented bit, read as '0'	
-n = Value at POR	'1' = Bit is set	'0' = Bit is cleared	x = Bit is unknown

REGISTER 9-2: CANSTAT - CAN STATUS REGISTER (ADDRESS: XEh)

R-1	R-0	R-0	U-0	R-0	R-0	R-0	U-0
OPMOD2	OPMOD1	OPMOD0	—	ICOD2	ICOD1	ICOD0	—
							bit 0
							bit 7

bit 7-5 **OPMOD<2:0>**: Operation Mode
 000 = Device is in Normal Operation Mode
 001 = Device is in Sleep Mode
 010 = Device is in Loopback Mode
 011 = Device is in Listen Only Mode
 100 = Device is in Configuration Mode

bit 4 **Unimplemented**: Read as '0'

bit 3-1 **ICOD<2:0>**: Interrupt Flag Code
 000 = No Interrupt
 001 = Error Interrupt
 010 = Wake Up Interrupt
 011 = TXB0 Interrupt
 100 = TXB1 Interrupt
 101 = TXB2 Interrupt
 110 = RXB0 Interrupt
 111 = RXB1 Interrupt

bit 0 **Unimplemented**: Read as '0'

Legend:			
R = Readable bit	W = Writable bit	U = Unimplemented bit, read as '0'	
-n = Value at POR	'1' = Bit is set	'0' = Bit is cleared	x = Bit is unknown

MCP2510

NOTES:

10.0 REGISTER MAP

The register map for the MCP2510 is shown in Table 10-1. Address locations for each register are determined by using the column (higher order 4 bits) and row (lower order 4 bits) values. The registers have been arranged to optimize the sequential reading and

writing of data. Some specific control and status registers allow individual bit modification using the SPI Bit Modify command. The registers that allow this command are shown as shaded locations in Table 10-1. A summary of the MCP2510 control registers is shown in Table 10-2.

TABLE 10-1: CAN CONTROLLER REGISTER MAP

Lower Address Bits	Higher Order Address Bits							
	x000 xxxx	x001 xxxx	x010 xxxx	x0011 xxxx	x100 xxxx	x101 xxxx	x110 xxxx	x111 xxxx
0000	RXF0SIDH	RXF3SIDH	RXM0SIDH	TXB0CTRL	TXB1CTRL	TXB2CTRL	RXB0CTRL	RXB1CTRL
0001	RXF0SIDL	RXF3SIDL	RXM0SIDL	TXB0SIDH	TXB1SIDH	TXB2SIDH	RXB0SIDH	RXB1SIDH
0010	RXF0EID8	RXF3EID8	RXM0EID8	TXB0SIDL	TXB1SIDL	TXB2SIDL	RXB0SIDL	RXB1SIDL
0011	RXF0EID0	RXF3EID0	RXM0EID0	TXB0EID8	TXB1EID8	TXB2EID8	RXB0EID8	RXB1EID8
0100	RXF1SIDH	RXF4SIDH	RXM1SIDH	TXB0EID0	TXB1EID0	TXB2EID0	RXB0EID0	RXB1EID0
0101	RXF1SIDL	RXF4SIDL	RXM1SIDL	TXB0DLC	TXB1DLC	TXB2DLC	RXB0DLC	RXB1DLC
0110	RXF1EID8	RXF4EID8	RXM1EID8	TXB0D0	TXB1D0	TXB2D0	RXB0D0	RXB1D0
0111	RXF1EID0	RXF4EID0	RXM1EID0	TXB0D1	TXB1D1	TXB2D1	RXB0D1	RXB1D1
1000	RXF2SIDH	RXF5SIDH	CNF3	TXB0D2	TXB1D2	TXB2D2	RXB0D2	RXB1D2
1001	RXF2SIDL	RXF5SIDL	CNF2	TXB0D3	TXB1D3	TXB2D3	RXB0D3	RXB1D3
1010	RXF2EID8	RXF5EID8	CNF1	TXB0D4	TXB1D4	TXB2D4	RXB0D4	RXB1D4
1011	RXF2EID0	RXF5EID0	CANINTE	TXB0D5	TXB1D5	TXB2D5	RXB0D5	RXB1D5
1100	BFPCTRL	TEC	CANINTF	TXB0D6	TXB1D6	TXB2D6	RXB0D6	RXB1D6
1101	TXRTSCTRL	REC	EFLG	TXB0D7	TXB1D7	TXB2D7	RXB0D7	RXB1D7
1110	CANSTAT	CANSTAT	CANSTAT	CANSTAT	CANSTAT	CANSTAT	CANSTAT	CANSTAT
1111	CANCTRL	CANCTRL	CANCTRL	CANCTRL	CANCTRL	CANCTRL	CANCTRL	CANCTRL

Note: Shaded register locations indicate that these allow the user to manipulate individual bits using the 'Bit Modify' Command.

TABLE 10-2: CONTROL REGISTER SUMMARY

Register Name	Address (Hex)	Bit 7	Bit 6	Bit 5	Bit 4	Bit 3	Bit 2	Bit 1	Bit 0	POR/RST Value
BFPCTRL	0C	—	—	B1BFS	B0BFS	B1BFE	B0BFE	B1BFM	B0BFM	--00 0000
TXRTSCTRL	0D	—	—	B2RTS	B1RTS	B0RTS	B2RTSM	B1RTSM	B0RTSM	--xx x000
CANSTAT	xE	OPMOD2	OPMOD1	OPMOD0	—	ICOD2	ICOD1	ICOD0	—	100- 000-
CANCTRL	xF	REQOP2	REQOP1	REQOP0	ABAT	—	CLKEN	CLKPRE1	CLKPRE0	1110 -111
TEC	1C	Transmit Error Counter								0000 0000
REC	1D	Receive Error Counter								0000 0000
CNF3	28	—	WAKFIL	—	—	—	PHSEG22	PHSEG21	PHSEG20	-0-- -000
CNF2	29	BTLMODE	SAM	PHSEG12	PHSEG11	PHSEG10	PRSEG2	PRSEG1	PRSEG0	0000 0000
CNF1	2A	SJW1	SJW0	BRP5	BRP4	BRP3	BRP2	BRP1	BRP0	0000 0000
CANINTE	2B	MERRE	WAKIE	ERRIE	TX2IE	TX1IE	TX0IE	RX1IE	RX0IE	0000 0000
CANINTF	2C	MERRF	WAKIF	ERRIF	TX2IF	TX1IF	TX0IF	RX1IF	RX0IF	0000 0000
EFLG	2D	RX1OVR	RX0OVR	TXBO	TXEP	RXEP	TXWAR	RXWAR	EWARN	0000 0000
TXB0CTRL	30	—	ABTF	MLOA	TXERR	TXREQ	—	TXP1	TXP0	-000 0-00
TXB1CTRL	40	—	ABTF	MLOA	TXERR	TXREQ	—	TXP1	TXP0	-000 0-00
TXB2CTRL	50	—	ABTF	MLOA	TXERR	TXREQ	—	TXP1	TXP0	-000 0-00
RXB0CTRL	60	—	RXM1	RXM0	—	RXRTR	BUKT	BUKT	FILHIT0	-00- 0000
RXB1CTRL	70	—	RSM1	RXM0	—	RXRTR	FILHIT2	FILHIT1	FILHIT0	-00- 0000

MCP2510

NOTES:

11.0 SPI INTERFACE

11.1 Overview

The MCP2510 is designed to interface directly with the Serial Peripheral Interface (SPI) port available on many microcontrollers and supports Mode 0,0 and Mode 1,1. Commands and data are sent to the device via the SI pin, with data being clocked in on the rising edge of SCK. Data is driven out by the MCP2510, on the SO line, on the falling edge of SCK. The $\overline{\text{CS}}$ pin must be held low while any operation is performed. Table 11-1 shows the instruction bytes for all operations. Refer to Figure 11-8 and Figure 11-9 for detailed input and output timing diagrams for both Mode 0,0 and Mode 1,1 operation.

11.2 Read Instruction

The Read Instruction is started by lowering the $\overline{\text{CS}}$ pin. The read instruction is then sent to the MCP2510 followed by the 8-bit address (A7 through A0). After the read instruction and address are sent, the data stored in the register at the selected address will be shifted out on the SO pin. The internal address pointer is automatically incremented to the next address after each byte of data is shifted out. Therefore it is possible to read the next consecutive register address by continuing to provide clock pulses. Any number of consecutive register locations can be read sequentially using this method. The read operation is terminated by raising the $\overline{\text{CS}}$ pin (Figure 11-2).

11.3 Write Instruction

The Write Instruction is started by lowering the $\overline{\text{CS}}$ pin. The write instruction is then sent to the MCP2510 followed by the address and at least one byte of data. It is possible to write to sequential registers by continuing to clock in data bytes, as long as $\overline{\text{CS}}$ is held low. Data will actually be written to the register on the rising edge of the SCK line for the DO bit. If the $\overline{\text{CS}}$ line is brought high before eight bits are loaded, the write will be aborted for that data byte, previous bytes in the command will have been written. Refer to the timing diagram in Figure 11-3 for more detailed illustration of the byte write sequence.

11.4 Request To Send (RTS) Instruction

The RTS command can be used to initiate message transmission for one or more of the transmit buffers.

The part is selected by lowering the $\overline{\text{CS}}$ pin and the RTS command byte is then sent to the MCP2510. As shown in Figure 11-4, the last 3 bits of this command indicate which transmit buffer(s) are enabled to send. This command will set the TxBnCTRL.TXREQ bit for the respective buffer(s). Any or all of the last three bits can be set in a single command. If the RTS command is sent with $nnn = 000$, the command will be ignored.

11.5 Read Status Instruction

The Read Status Instruction allows single instruction access to some of the often used status bits for message reception and transmission.

The part is selected by lowering the $\overline{\text{CS}}$ pin and the read status command byte, shown in Figure 11-6, is sent to the MCP2510. After the command byte is sent, the MCP2510 will return eight bits of data that contain the status. If additional clocks are sent after the first eight bits are transmitted, the MCP2510 will continue to output the status bits as long as the $\overline{\text{CS}}$ pin is held low and clocks are provided on SCK. Each status bit returned in this command may also be read by using the standard read command with the appropriate register address.

11.6 Bit Modify Instruction

The Bit Modify Instruction provides a means for setting or clearing individual bits in specific status and control registers. This command is not available for all registers. See Section 10.0 (register map) to determine which registers allow the use of this command.

The part is selected by lowering the $\overline{\text{CS}}$ pin and the Bit Modify command byte is then sent to the MCP2510. After the command byte is sent, the address for the register is sent followed by the mask byte and then the data byte. The mask byte determines which bits in the register will be allowed to change. A '1' in the mask byte will allow a bit in the register to change and a '0' will not. The data byte determines what value the modified bits in the register will be changed to. A '1' in the data byte will set the bit and a '0' will clear the bit, provided that the mask for that bit is set to a '1'. (see Figure 11-1)

11.7 Reset Instruction

The Reset Instruction can be used to re-initialize the internal registers of the MCP2510 and set configuration mode. This command provides the same functionality, via the SPI interface, as the $\overline{\text{RESET}}$ pin. The Reset instruction is a single byte instruction which requires selecting the device by pulling $\overline{\text{CS}}$ low, sending the instruction byte, and then raising $\overline{\text{CS}}$. It is highly recommended that the reset command be sent (or the $\overline{\text{RESET}}$ pin be lowered) as part of the power-on initialization sequence. The MCP2510 will be held in reset for 128 FOSC cycles.

MCP2510

FIGURE 11-1: BIT MODIFY

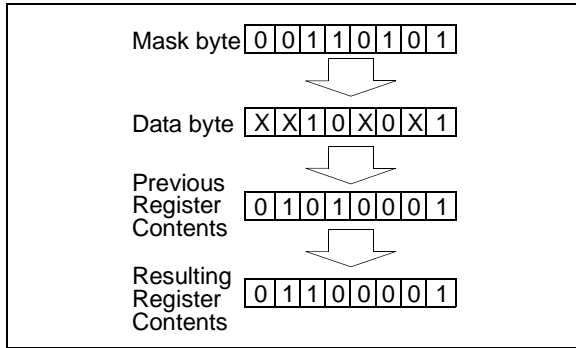

TABLE 11-1: SPI INSTRUCTION SET

Instruction Name	Instruction Format	Description
RESET	1100 0000	Resets internal registers to default state, set configuration mode
READ	0000 0011	Read data from register beginning at selected address
WRITE	0000 0010	Write data to register beginning at selected address
RTS (Request To Send)	1000 0nnn	Sets TXBnCTRL.TXREQ bit for one or more transmit buffers <div style="text-align: center;"> <p>1000 0nnn</p> <p>Request to send for TXB2 ——— ↑ ——— Request to send for TXB0</p> <p>Request to send for TXB1</p> </div>
Read Status	1010 0000	Polling command that outputs status bits for transmit/receive functions
Bit Modify	0000 0101	Bit modify selected registers

FIGURE 11-2: READ INSTRUCTION

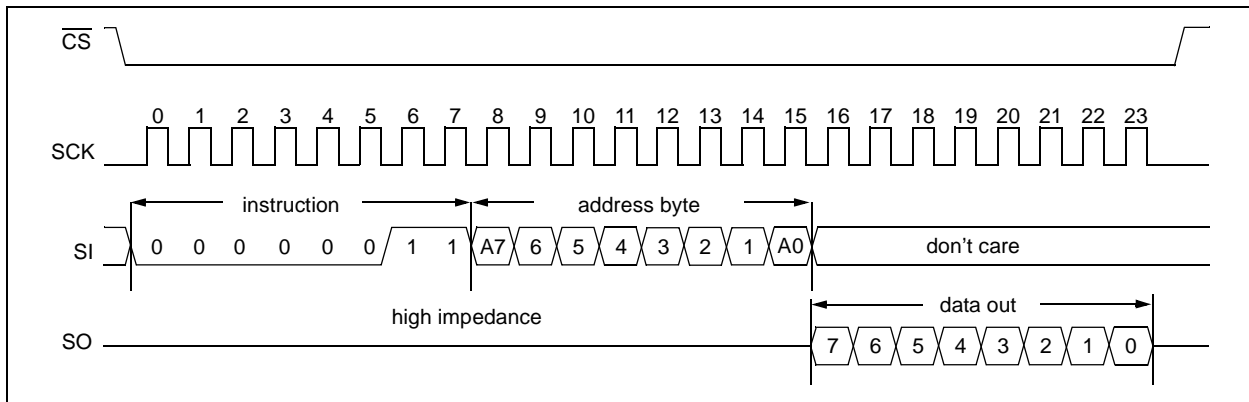

FIGURE 11-3: BYTE WRITE INSTRUCTION

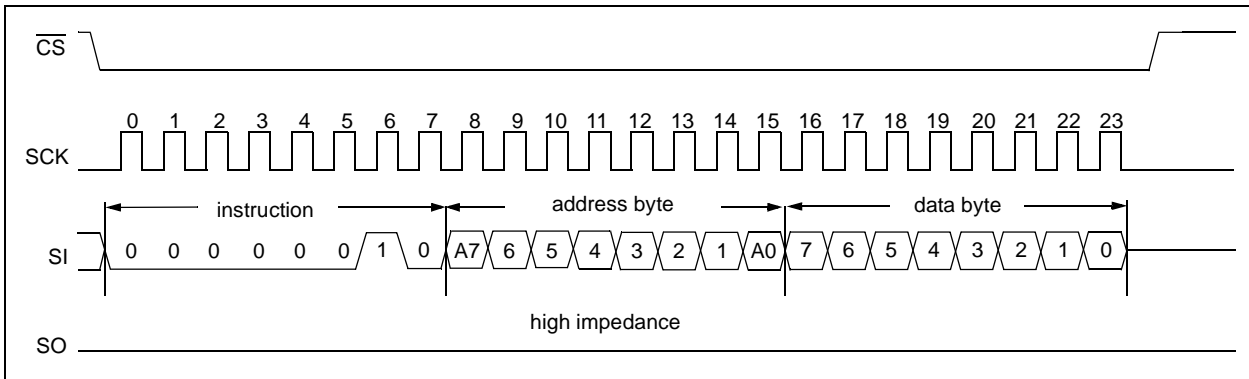

FIGURE 11-4: REQUEST TO SEND INSTRUCTION

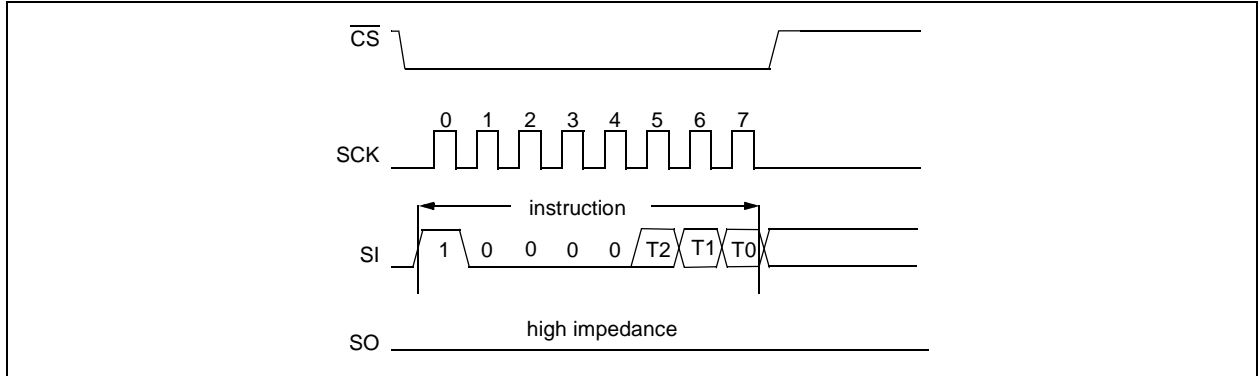

FIGURE 11-5: BIT MODIFY INSTRUCTION

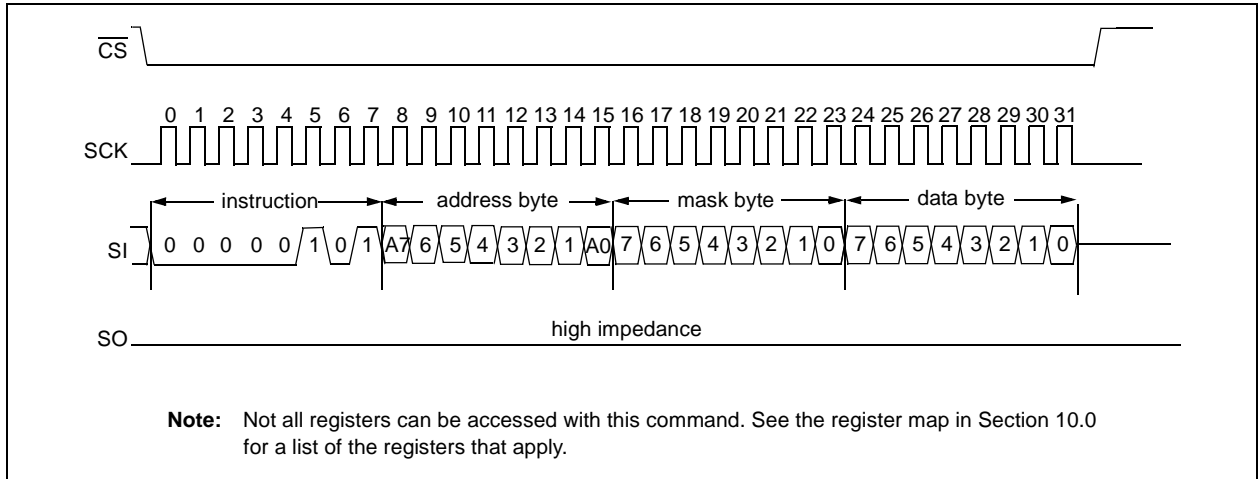
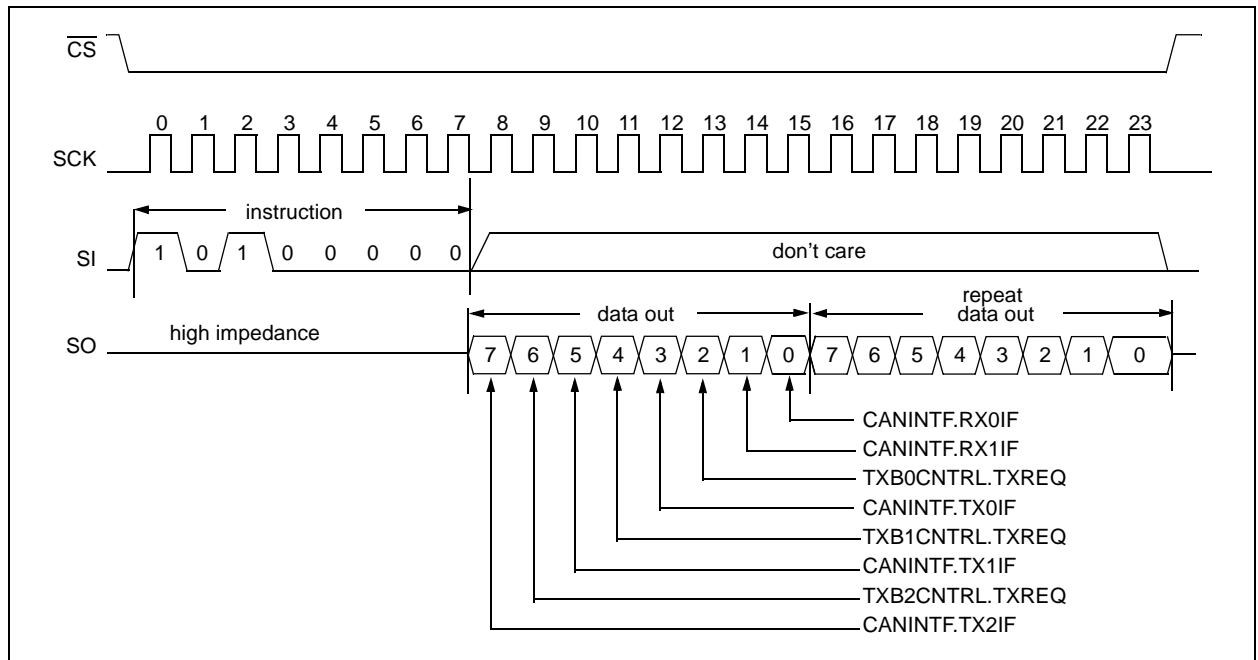

FIGURE 11-6: READ STATUS INSTRUCTION



MCP2510

FIGURE 11-7: RESET INSTRUCTION

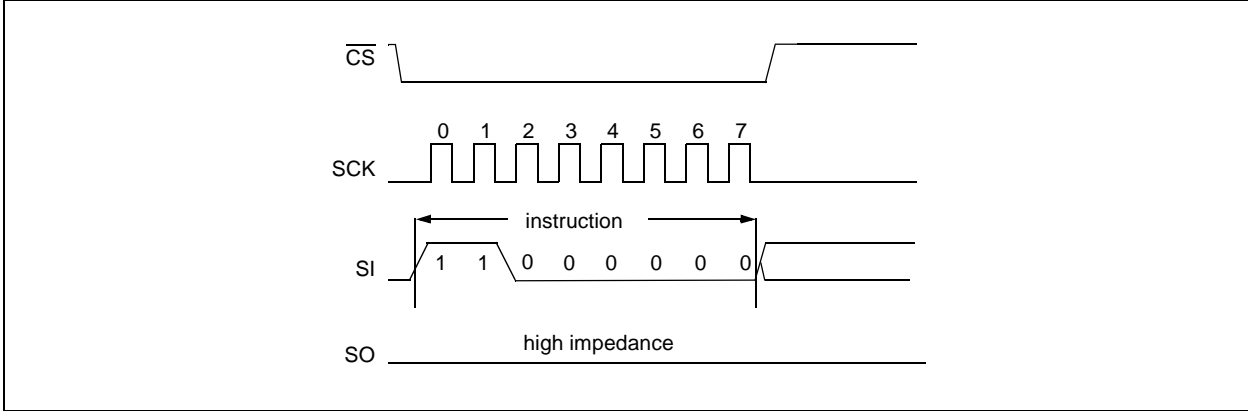

FIGURE 11-8: SPI INPUT TIMING

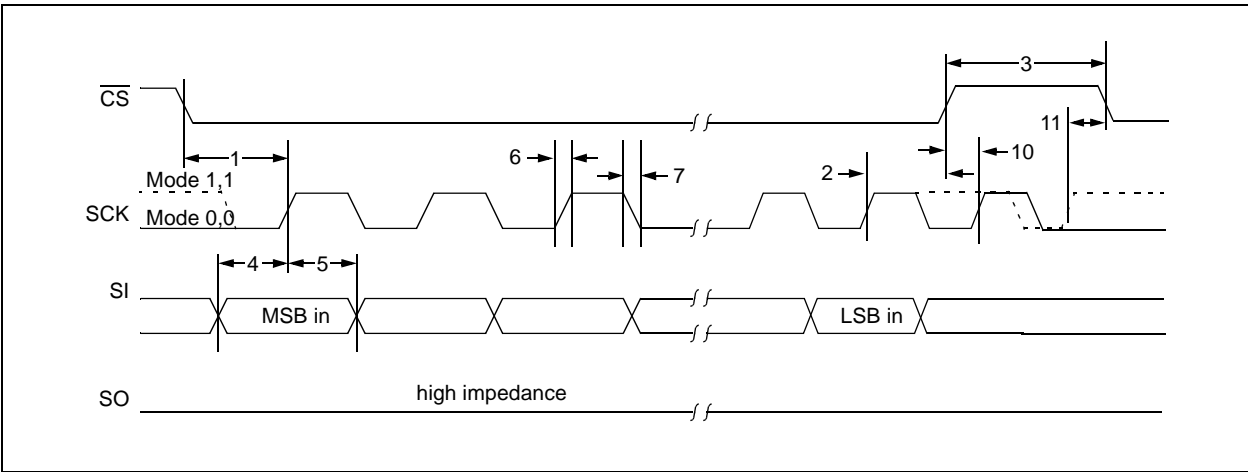
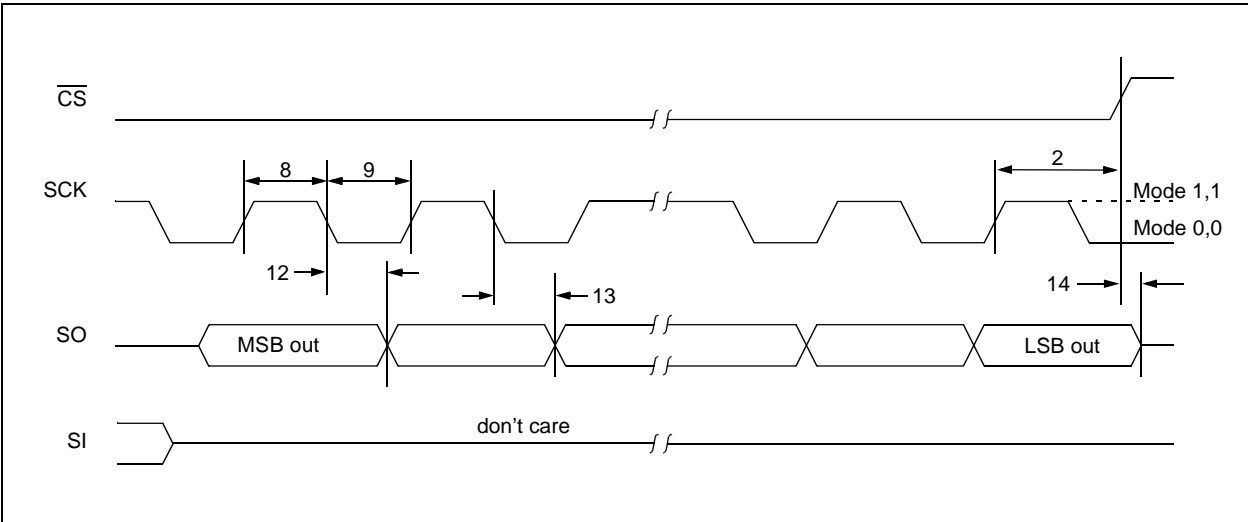

FIGURE 11-9: SPI OUTPUT TIMING



12.0 ELECTRICAL CHARACTERISTICS

12.1 Absolute Maximum Ratings†

VDD.....	7.0V
All inputs and outputs w.r.t. Vss	-0.6V to VDD +1.0V
Storage temperature	-65°C to +150°C
Ambient temp. with power applied	-65°C to +125°C
Soldering temperature of leads (10 seconds)	+300°C
ESD protection on all pins	≥ 4 kV

† **Notice:** Stresses above those listed under “Maximum Ratings” may cause permanent damage to the device. This is a stress rating only and functional operation of the device at those or any other conditions above those indicated in the operational listings of this specification is not implied. Exposure to maximum rating conditions for extended periods may affect device reliability.

MCP2510

TABLE 12-1: DC CHARACTERISTICS

DC Characteristics			Industrial (I):		Extended (E):	
			T _{AMB} = -40°C to +85°C		V _{DD} = 3.0V to 5.5V	
			T _{AMB} = -40°C to +125°C		V _{DD} = 4.5V to 5.5V	
Param. No.	Sym	Characteristic	Min	Max	Units	Conditions
	V _{DD}	Supply Voltage	3.0	5.5	V	
	V _{RET}	Register Retention Voltage	2.4	—	V	
	V _{IH}	High Level Input Voltage RXCAN SCK, $\overline{\text{CS}}$, SI, $\overline{\text{TXnRTS}}$ Pins OSC1 RESET	2 .7 V _{DD} .85 V _{DD} .85 V _{DD}	V _{DD} +1 V _{DD} +1 V _{DD} V _{DD}	V V V V	Note
	V _{IL}	Low Level Input Voltage RXCAN, $\overline{\text{TXnRTS}}$ Pins SCK, $\overline{\text{CS}}$, SI OSC1 RESET	-0.3 -0.3 V _{SS} V _{SS}	.15 V _{DD} 0.4 .3 V _{DD} .15 V _{DD}	V V V V	Note
	V _{OL}	Low Level Output Voltage TXCAN $\overline{\text{RXnBF}}$ Pins SO, CLKOUT $\overline{\text{INT}}$	— — — —	0.6 0.6 0.6 0.6	V V V V	I _{OL} = -6.0 mA, V _{DD} = 4.5V I _{OL} = -8.5 mA, V _{DD} = 4.5V I _{OL} = -2.1 mA, V _{DD} = 4.5V I _{OL} = -1.6 mA, V _{DD} = 4.5V
	V _{OH}	High Level Output Voltage TXCAN, $\overline{\text{RXnBF}}$ Pins SO, CLKOUT $\overline{\text{INT}}$	V _{DD} -0.7 V _{DD} -0.5 V _{DD} -0.7	— — —	V V V	I _{OH} = 3.0 mA, V _{DD} = 4.5V, I temp I _{OH} = 400 μ A, V _{DD} = 4.5V I _{OH} = 1.0 mA, V _{DD} = 4.5V
	I _{LI}	Input Leakage Current All I/O except OSC1 and TXnRTS pins OSC1 Pin	-1 -5	+1 +5	μ A μ A	$\overline{\text{CS}} = \overline{\text{RESET}} = \text{V}_{\text{DD}}$, V _{IN} = V _{SS} to V _{DD}
	C _{INT}	Internal Capacitance (All Inputs And Outputs)	—	7	pF	T _{AMB} = 25°C, f _C = 1.0 MHz, V _{DD} = 5.0V (Note)
	I _{DD}	Operating Current	—	10	mA	V _{DD} = 5.5V, F _{OSC} = 25 MHz, F _{CLK} = 1 MHz, SO = Open
	I _{DD5}	Standby Current (Sleep Mode)	—	5	μ A	$\overline{\text{CS}}$, $\overline{\text{TXnRTS}} = \text{V}_{\text{DD}}$, Inputs tied to V _{DD} or V _{SS}

Note: This parameter is periodically sampled and not 100% tested.

TABLE 12-2: OSCILLATOR TIMING CHARACTERISTICS

Oscillator Timing Characteristics			Industrial (I):		TAMB = -40°C to +85°C		VDD = 3.0V to 5.5V	
			Extended (E):		TAMB = -40°C to +125°C		VDD = 4.5V to 5.5V	
Param. No.	Sym	Characteristic	Min	Max	Units	Conditions		
	FOSC	Clock In Frequency	1	25	MHz	4.5V to 5.5V		
			1	16	MHz	3.0V to 4.5V		
	TOSC	Clock In Period	40	1000	ns	4.5V to 5.5V		
			62.5	1000	ns	3.0V to 4.5V		
	TDUTY	Duty Cycle (External Clock Input)	0.45	0.55	—	TOSH / (TOSH + TOSL)		

Note: This parameter is periodically sampled and not 100% tested.

TABLE 12-3: CAN INTERFACE AC CHARACTERISTICS

CAN Interface AC Characteristics			Industrial (I):		TAMB = -40°C to +85°C		VDD = 3.0V to 5.5V	
			Extended (E):		TAMB = -40°C to +125°C		VDD = 4.5V to 5.5V	
Param. No.	Sym	Characteristic	Min	Max	Units	Conditions		
	TWF	Wakeup Noise Filter	50	—	ns			
	TDCLK	CLOCKOUT Propagation Delay	—	100	ns			

TABLE 12-4: CLKOUT PIN AC/DC CHARACTERISTICS

CLKOUT Pin AC/DC Characteristics			Industrial (I):		TAMB = -40°C to +85°C		VDD = 3.0V to 5.5V	
			Extended (E):		TAMB = -40°C to +125°C		VDD = 4.5V to 5.5V	
Param. No.	Sym	Characteristic	Min	Max	Units	Conditions		
	t _h CLKOUT	CLKOUT Pin High Time	15	—	ns	TOSC = 40 ns (Note)		
	t _l CLKOUT	CLKOUT Pin Low Time	15	—	ns	TOSC = 40 ns (Note)		
	t _r CLKOUT	CLKOUT Pin Rise Time	—	5	ns	Measured from 0.3 VDD to 0.7 VDD (Note)		
	t _f CLKOUT	CLKOUT Pin Fall Time	—	5	ns	Measured from 0.7 VDD to 0.3 VDD (Note)		
	t _d CLKOUT	CLOCKOUT Propagation Delay	—	100	ns			

Note: CLKOUT prescaler set to divide by one.

MCP2510

TABLE 12-5: SPI INTERFACE AC CHARACTERISTICS

SPI Interface AC Characteristics			Industrial (I): T _{AMB} = -40°C to +85°C		V _{DD} = 3.0V to 5.5V	
			Extended (E): T _{AMB} = -40°C to +125°C		V _{DD} = 4.5V to 5.5V	
Param. No.	Sym	Characteristic	Min	Max	Units	Conditions
	FCLK	Clock Frequency	—	5	MHz	V _{DD} = 4.5V to 5.5V
			—	4	MHz	V _{DD} = 4.5V to 5.5V (E temp)
			—	2.5	MHz	V _{DD} = 3.0V to 4.5V
1	T _{CSS}	CS Setup Time	100	—	ns	
2	T _{CSH}	CS Hold Time	100	—	ns	V _{DD} = 4.5V to 5.5V
			115	—	ns	V _{DD} = 4.5V to 5.5V (E temp)
			180	—	ns	V _{DD} = 3.0V to 4.5V
3	T _{CSD}	CS Disable Time	100	—	ns	V _{DD} = 4.5V to 5.5V
			100	—	ns	V _{DD} = 4.5V to 5.5V (E temp)
			280	—	ns	V _{DD} = 3.0V to 4.5V
4	T _{SU}	Data Setup Time	20	—	ns	V _{DD} = 4.5V to 5.5V
			20	—	ns	V _{DD} = 4.5V to 5.5V (E temp)
			30	—	ns	V _{DD} = 3.0V to 4.5V
5	T _{HD}	Data Hold Time	20	—	ns	V _{DD} = 4.5V to 5.5V
			20	—	ns	V _{DD} = 4.5V to 5.5V (E temp)
			50	—	ns	V _{DD} = 3.0V to 4.5V
6	T _R	CLK Rise Time	—	2	μs	Note
7	T _F	CLK Fall Time	—	2	μs	Note
8	T _{HI}	Clock High Time	90	—	ns	V _{DD} = 4.5V to 5.5V
			115	—	ns	V _{DD} = 4.5V to 5.5V (E temp)
			180	—	ns	V _{DD} = 3.0V to 4.5V
9	T _{LO}	Clock Low Time	90	—	ns	V _{DD} = 4.5V to 5.5V
			115	—	ns	V _{DD} = 4.5V to 5.5V (E temp)
			180	—	ns	V _{DD} = 3.0V to 4.5V
10	T _{CLD}	Clock Delay Time	50	—	ns	
11	T _{CLE}	Clock Enable Time	50	—	ns	
12	T _V	Output Valid from Clock Low	—	90	ns	V _{DD} = 4.5V to 5.5V
			—	115	ns	V _{DD} = 4.5V to 5.5V (E temp)
			—	180	ns	V _{DD} = 3.0V to 4.5V
13	T _{HO}	Output Hold Time	0	—	ns	Note
14	T _{DIS}	Output Disable Time	—	200	ns	Note

Note: This parameter is not 100% tested.

13.0 PACKAGING INFORMATION

13.1 Package Marking Information

18-Lead PDIP (300 mil)

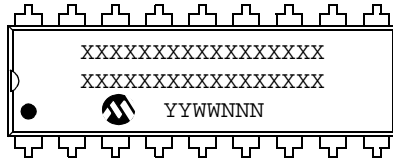

Example:

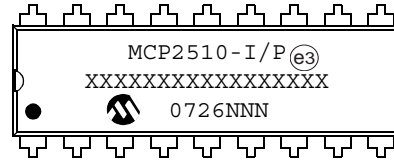

18-Lead SOIC (300 mil)

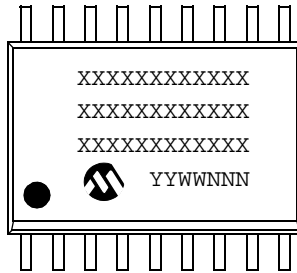

Example:

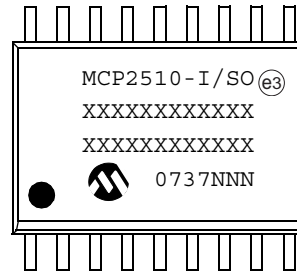

20-Lead TSSOP (4.4 mm)

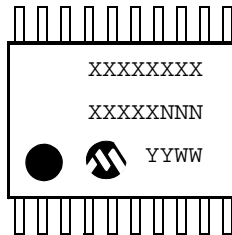

Example:

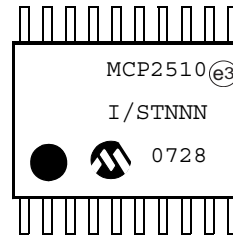

Legend:	XX...X	Customer-specific information
	Y	Year code (last digit of calendar year)
	YY	Year code (last 2 digits of calendar year)
	WW	Week code (week of January 1 is week '01')
	NNN	Alphanumeric traceability code
	(e3)	Pb-free JEDEC designator for Matte Tin (Sn)
	*	This package is Pb-free. The Pb-free JEDEC designator (e3) can be found on the outer packaging for this package.
Note:	In the event the full Microchip part number cannot be marked on one line, it will be carried over to the next line, thus limiting the number of available characters for customer-specific information.	

MCP2510

18-Lead Plastic Dual In-Line (P) – 300 mil Body [PDIP]

Note: For the most current package drawings, please see the Microchip Packaging Specification located at <http://www.microchip.com/packaging>

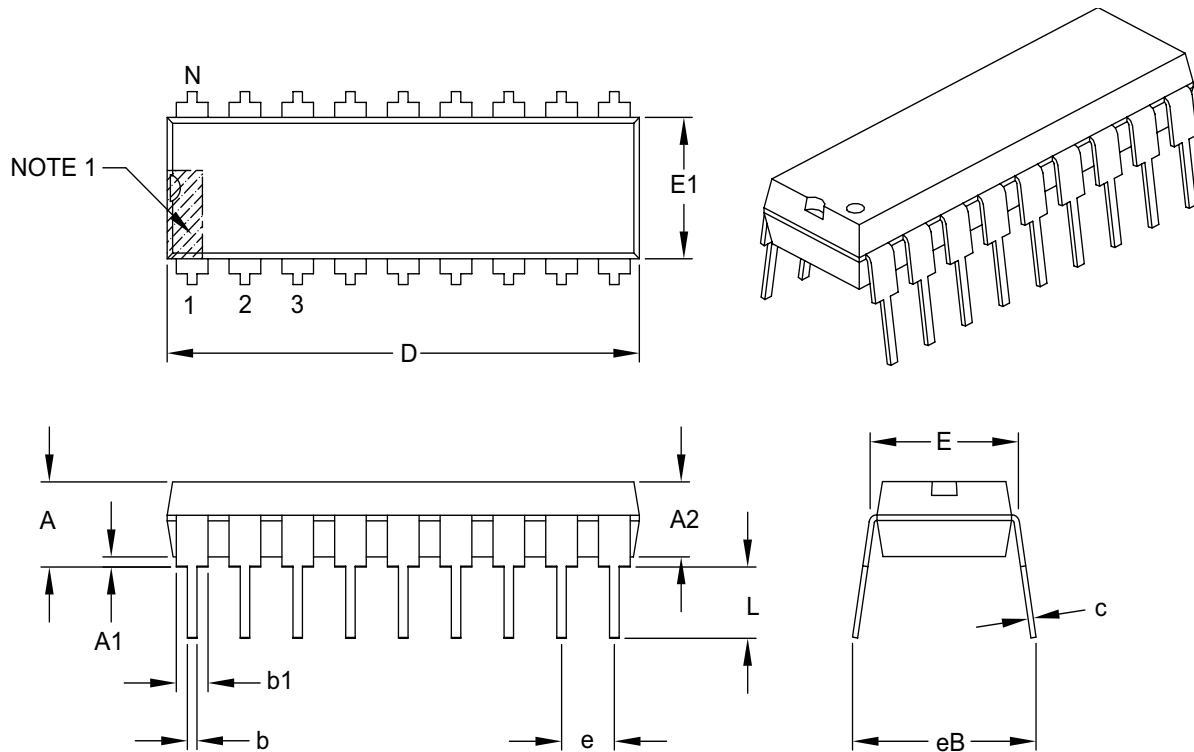

Dimension Limits	Units	INCHES		
		MIN	NOM	MAX
Number of Pins	N	18		
Pitch	e	.100 BSC		
Top to Seating Plane	A	–	–	.210
Molded Package Thickness	A2	.115	.130	.195
Base to Seating Plane	A1	.015	–	–
Shoulder to Shoulder Width	E	.300	.310	.325
Molded Package Width	E1	.240	.250	.280
Overall Length	D	.880	.900	.920
Tip to Seating Plane	L	.115	.130	.150
Lead Thickness	c	.008	.010	.014
Upper Lead Width	b1	.045	.060	.070
Lower Lead Width	b	.014	.018	.022
Overall Row Spacing §	eB	–	–	.430

Notes:

- Pin 1 visual index feature may vary, but must be located within the hatched area.
- § Significant Characteristic.
- Dimensions D and E1 do not include mold flash or protrusions. Mold flash or protrusions shall not exceed .010" per side.
- Dimensioning and tolerancing per ASME Y14.5M.

BSC: Basic Dimension. Theoretically exact value shown without tolerances.

Microchip Technology Drawing C04-007B

18-Lead Plastic Small Outline (SO) – Wide, 7.50 mm Body [SOIC]

Note: For the most current package drawings, please see the Microchip Packaging Specification located at <http://www.microchip.com/packaging>

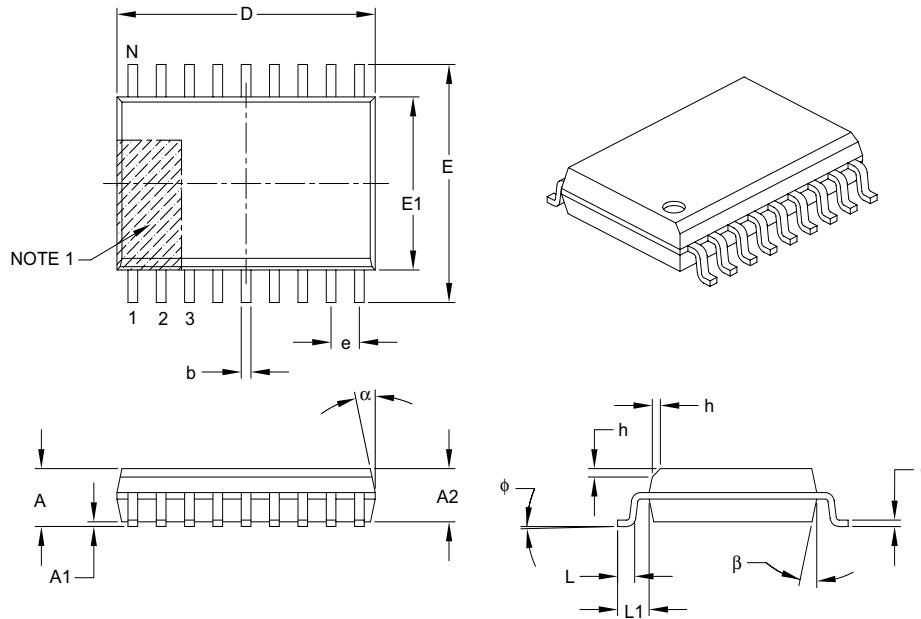

Dimension Limits	Units	MILLIMETERS		
		MIN	NOM	MAX
Number of Pins	N	18		
Pitch	e	1.27 BSC		
Overall Height	A	–	–	2.65
Molded Package Thickness	A2	2.05	–	–
Standoff §	A1	0.10	–	0.30
Overall Width	E	10.30 BSC		
Molded Package Width	E1	7.50 BSC		
Overall Length	D	11.55 BSC		
Chamfer (optional)	h	0.25	–	0.75
Foot Length	L	0.40	–	1.27
Footprint	L1	1.40 REF		
Foot Angle	φ	0°	–	8°
Lead Thickness	c	0.20	–	0.33
Lead Width	b	0.31	–	0.51
Mold Draft Angle Top	α	5°	–	15°
Mold Draft Angle Bottom	β	5°	–	15°

Notes:

- Pin 1 visual index feature may vary, but must be located within the hatched area.
- § Significant Characteristic.
- Dimensions D and E1 do not include mold flash or protrusions. Mold flash or protrusions shall not exceed 0.15 mm per side.
- Dimensioning and tolerancing per ASME Y14.5M.

BSC: Basic Dimension. Theoretically exact value shown without tolerances.

REF: Reference Dimension, usually without tolerance, for information purposes only.

Microchip Technology Drawing C04-051B

MCP2510

20-Lead Plastic Thin Shrink Small Outline (ST) – 4.4 mm Body [TSSOP]

Note: For the most current package drawings, please see the Microchip Packaging Specification located at <http://www.microchip.com/packaging>

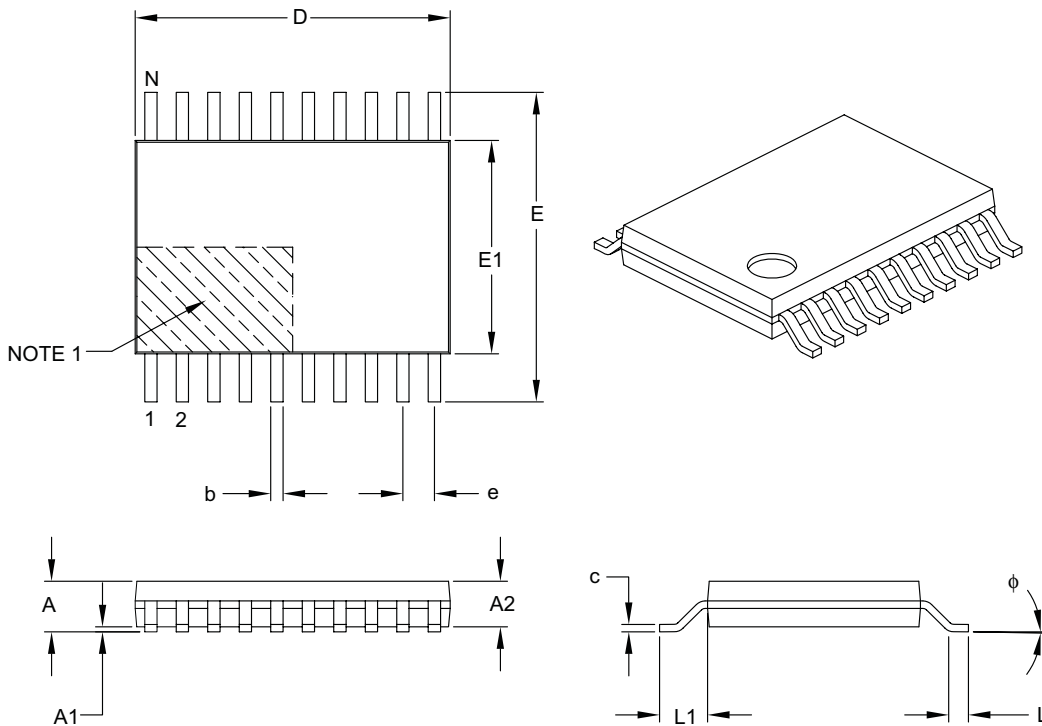

Dimension Limits	Units	MILLIMETERS		
		MIN	NOM	MAX
Number of Pins	N	20		
Pitch	e	0.65 BSC		
Overall Height	A	–	–	1.20
Molded Package Thickness	A2	0.80	1.00	1.05
Standoff	A1	0.05	–	0.15
Overall Width	E	6.40 BSC		
Molded Package Width	E1	4.30	4.40	4.50
Molded Package Length	D	6.40	6.50	6.60
Foot Length	L	0.45	0.60	0.75
Footprint	L1	1.00 REF		
Foot Angle	ϕ	0°	–	8°
Lead Thickness	c	0.09	–	0.20
Lead Width	b	0.19	–	0.30

Notes:

- Pin 1 visual index feature may vary, but must be located within the hatched area.
- Dimensions D and E1 do not include mold flash or protrusions. Mold flash or protrusions shall not exceed 0.15 mm per side.
- Dimensioning and tolerancing per ASME Y14.5M.
 BSC: Basic Dimension. Theoretically exact value shown without tolerances.
 REF: Reference Dimension, usually without tolerance, for information purposes only.

Microchip Technology Drawing C04-088B

APPENDIX A: REVISION HISTORY

Revision F (January 2007)

This revision includes updates to the packaging diagrams.

NOTES:

INDEX

A

Acknowledge Error 41

B

BFpctrl - RXnBF Pin Control and Status Register 26
 Bit Error 41
 BIT Modify instruction 59
 Bit Modify Instruction 57
 Bit Timing 35
 Bit Timing Configuration Registers 39
 Bit Timing Logic 6
 Bus Activity Wakeup Interrupt 45
 Bus Off 46
 Byte Write instruction 58

C

CAN Buffers and Protocol Engine Block Diagram 5
 CAN controller Register Map 55
 CAN Interface AC characteristics 63
 CAN Protocol Engine 6
 CAN Protocol Engine Block Diagram 6
 CANCTRL - CAN Control Register 52
 CANINTE - Interrupt Enable Register 47
 CANSTAT - CAN Status Register 53
 CNF1 - Configuration Register1 39
 CNF2 - Configuration Register2 40
 CNF3 - Configuration Register3 40
 Configuration Mode 51
 CRC Error 41
 Crystal/ceramic resonator operation 49
 Cyclic Redundancy Check 6

D

DC Characteristics 62
 Description 1
 Device Functionality 5

E

EFLG - Error Flag Register 43
 Electrical Characteristics 61
 Errata 2
 Error Detection 41
 Error Frame 7, 13
 Error Interrupt 46
 Error Management Logic 6
 Error Modes 42
 Error Modes and Error Counters 41
 Error States 41
 Extended Data Frame 7
 External Clock (osc1) Timing characteristics 63
 External Clock Source 49
 External Series Resonant Crystal Oscillator Circuit 50

F

Features 1
 Filter/Mask Truth Table 29
 Form Error 41
 Frame Types 7

H

Hard Synchronization 37

I

Information Processing Time 36
 Initiating Message Transmission 15
 Interframe Space 8
 Interrupt Acknowledge 46

Interrupts 45

L

Lenghtening a Bit Period 37
 Listen Only Mode 51
 Loopback Mode 52

M

Maximum Ratings 61
 Message Acceptance Filter 30
 Message Acceptance Filters and Masks 29
 Message Reception 21
 Message Reception Flowchart 23
 Modes of Operation 51

N

Normal Mode 52

O

Oscillator 49
 Oscillator Tolerance 38
 Overload Frame 8
 Overview 3

P

Package Types 1
 Packaging Information 65
 Phase Buffer Segments 36
 Programming Time Segments 38
 Propagation Segment 36
 Protocol Finite State Machine 6

R

Read Instruction 57
 Read instruction Diagram 58
 Read Status Instruction 57
 Read Status instruction 59
 REC - Receiver Error Count 42
 Receive Buffers 21
 Receive Buffers Diagram 22
 Receive Interrupt 45
 Receive Message Buffering 21
 Receiver Error Passive 46
 Receiver Overrun 46
 Receiver Warning 46
 Register Map 55
 Remote Frame 7
 Request To Send (RTS) Instruction 57, 59
 Resynchronization 37
 RXB0BF and RXB1BF Pins 21
 RXB0CTRL - Receive Buffer 0 Control Register 24
 RXB1CTRL - Receive Buffer 1 Control Register 25
 RXBnDLC - Receive Buffer n Data Length Code 28
 RXBnDm - Receive Buffer n Data Field Byte m 28
 RXBnEID0 - Receive Buffer n Extended Identifier Low .. 28
 RXBnEID8 - Receive Buffer n Extended Identifier Mid .. 27
 RXBnSIDH - Receive Buffer n Standard Identifier High .. 26
 RXBnSIDL - Receive Buffer n Standard Identifier Low .. 27
 RXFnEID0 - Acceptance Filter n Extended Identifier Low 32
 RXFnEID8 - Acceptance Filter n Extended Identifier Mid 31
 RXFnSIDH - Acceptance Filter n Standard Identifier High 30
 RXFnSIDL - Acceptance Filter n Standard Identifier Low 31
 RXMnEID0 - Acceptance Filter Mask n Extended Identifier
 Low 33
 RXMnEID8 - Acceptance Filter Mask n Extended Identifier
 Mid 33
 RXMnSIDH - Acceptance Filter Mask n Standard Identifier
 High 32

MCP2510

RXMnSIDL - Acceptance Filter Mask n Standard Identifier
Low32

S

Sample Point36
Shortening a Bit Period38
Sleep Mode51
SPI Interface57
SPI Interface Overview57
SPI Port AC Characteristics64
Standard Data Frame7
Stuff Error41
Synchronization37
Synchronization Rules37
Synchronization Segment36

T

TEC - Transmitter Error Count42
Time Quanta36
Transmit Interrupt45
Transmit Message Aborting15
Transmit Message Buffering15
Transmit Message Buffers15
Transmit Message flowchart16
Transmit Message Priority15
Transmitter Error Passive46
Transmitter Warning46
TXBnCTRL Transmit buffer n Control Register17
TXBnDm - Transmit Buffer n Data Field Byte m20
TXBnEID0 - Transmit Buffer n Extended Identifier Low20
TXBnEID8 - Transmit Buffer n Extended Identifier Mid19
TXBnEIDH - Transmit Buffer n Extended Identifier High19
TXBnSIDH - Transmit Buffer n Standard Identifier High18
TXBnSIDL - Transmit Buffer n Standard Identifier Low19
TXnRTS Pins15
TXRTSCTRL - TXBNRTS Pin Control and Status Register18
Typical System Implementation4

W

WAKE-up functions51
Write Instruction57
WWW, On-Line Support2

THE MICROCHIP WEB SITE

Microchip provides online support via our WWW site at www.microchip.com. This web site is used as a means to make files and information easily available to customers. Accessible by using your favorite Internet browser, the web site contains the following information:

- **Product Support** – Data sheets and errata, application notes and sample programs, design resources, user's guides and hardware support documents, latest software releases and archived software
- **General Technical Support** – Frequently Asked Questions (FAQ), technical support requests, online discussion groups, Microchip consultant program member listing
- **Business of Microchip** – Product selector and ordering guides, latest Microchip press releases, listing of seminars and events, listings of Microchip sales offices, distributors and factory representatives

CUSTOMER CHANGE NOTIFICATION SERVICE

Microchip's customer notification service helps keep customers current on Microchip products. Subscribers will receive e-mail notification whenever there are changes, updates, revisions or errata related to a specified product family or development tool of interest.

To register, access the Microchip web site at www.microchip.com, click on Customer Change Notification and follow the registration instructions.

CUSTOMER SUPPORT

Users of Microchip products can receive assistance through several channels:

- Distributor or Representative
- Local Sales Office
- Field Application Engineer (FAE)
- Technical Support
- Development Systems Information Line

Customers should contact their distributor, representative or field application engineer (FAE) for support. Local sales offices are also available to help customers. A listing of sales offices and locations is included in the back of this document.

Technical support is available through the web site at: <http://support.microchip.com>

MCP2510

READER RESPONSE

It is our intention to provide you with the best documentation possible to ensure successful use of your Microchip product. If you wish to provide your comments on organization, clarity, subject matter, and ways in which our documentation can better serve you, please FAX your comments to the Technical Publications Manager at (480) 792-4150.

Please list the following information, and use this outline to provide us with your comments about this document.

To: Technical Publications Manager
RE: Reader Response
Total Pages Sent _____

From: Name _____
Company _____
Address _____
City / State / ZIP / Country _____
Telephone: (_____) _____ - _____ FAX: (_____) _____ - _____

Application (optional):

Would you like a reply? ___Y ___N

Device: MCP2510

Literature Number: DS21291F

Questions:

1. What are the best features of this document?

2. How does this document meet your hardware and software development needs?

3. Do you find the organization of this document easy to follow? If not, why?

4. What additions to the document do you think would enhance the structure and subject?

5. What deletions from the document could be made without affecting the overall usefulness?

6. Is there any incorrect or misleading information (what and where)?

7. How would you improve this document?

PRODUCT IDENTIFICATION SYSTEM

To order or obtain information, e.g., on pricing or delivery, refer to the factory or the listed sales office.

<u>PART NO.</u>		<u>X</u>	<u>/XX</u>
Device	Temperature Range		Package
Device:	MCP2510: CAN Controller w/SPI Interface MCP2510T: CAN Controller w/SPI Interface (Tape and Reel)		
Temperature Range:	- = -40°C to +85°C E = -40°C to +125°C		
Package:	P = Plastic DIP (300 mil Body), 18-Lead SO = Plastic SOIC (300 mil Body), 18-Lead ST = TSSOP, (4.4 mm Body), 20-Lead		

Examples:			
a)	MCP2510-E/P:	Extended	temperature, PDIP package.
b)	MCP2510-I/P:	Industrial	temperature, PDIP package.
c)	MCP2510-E/SO:	Extended	temperature, SOIC package.
d)	MCP2510-I/SO:	Industrial	temperature, SOIC package.
e)	MCP2510-I/SO:	Tape and Reel, Industrial	temperature, SOIC package.
f)	MCP2510I/ST:	Industrial	temperature, TSSOP package.
g)	MCP2510T-I/ST:	Tape and Reel, Industrial	temperature, TSSOP package.

MCP2510

NOTES:

Note the following details of the code protection feature on Microchip devices:

- Microchip products meet the specification contained in their particular Microchip Data Sheet.
- Microchip believes that its family of products is one of the most secure families of its kind on the market today, when used in the intended manner and under normal conditions.
- There are dishonest and possibly illegal methods used to breach the code protection feature. All of these methods, to our knowledge, require using the Microchip products in a manner outside the operating specifications contained in Microchip's Data Sheets. Most likely, the person doing so is engaged in theft of intellectual property.
- Microchip is willing to work with the customer who is concerned about the integrity of their code.
- Neither Microchip nor any other semiconductor manufacturer can guarantee the security of their code. Code protection does not mean that we are guaranteeing the product as "unbreakable."

Code protection is constantly evolving. We at Microchip are committed to continuously improving the code protection features of our products. Attempts to break Microchip's code protection feature may be a violation of the Digital Millennium Copyright Act. If such acts allow unauthorized access to your software or other copyrighted work, you may have a right to sue for relief under that Act.

Information contained in this publication regarding device applications and the like is provided only for your convenience and may be superseded by updates. It is your responsibility to ensure that your application meets with your specifications. MICROCHIP MAKES NO REPRESENTATIONS OR WARRANTIES OF ANY KIND WHETHER EXPRESS OR IMPLIED, WRITTEN OR ORAL, STATUTORY OR OTHERWISE, RELATED TO THE INFORMATION, INCLUDING BUT NOT LIMITED TO ITS CONDITION, QUALITY, PERFORMANCE, MERCHANTABILITY OR FITNESS FOR PURPOSE. Microchip disclaims all liability arising from this information and its use. Use of Microchip devices in life support and/or safety applications is entirely at the buyer's risk, and the buyer agrees to defend, indemnify and hold harmless Microchip from any and all damages, claims, suits, or expenses resulting from such use. No licenses are conveyed, implicitly or otherwise, under any Microchip intellectual property rights.

Trademarks

The Microchip name and logo, the Microchip logo, Accuron, dsPIC, KEELOQ, microID, MPLAB, PIC, PICmicro, PICSTART, PRO MATE, PowerSmart, rPIC, and SmartShunt are registered trademarks of Microchip Technology Incorporated in the U.S.A. and other countries.

AmpLab, FilterLab, Migratable Memory, MXDEV, MXLAB, SEEVAL, SmartSensor and The Embedded Control Solutions Company are registered trademarks of Microchip Technology Incorporated in the U.S.A.

Analog-for-the-Digital Age, Application Maestro, CodeGuard, dsPICDEM, dsPICDEM.net, dsPICworks, ECAN, ECONOMONITOR, FanSense, FlexROM, fuzzyLAB, In-Circuit Serial Programming, ICSP, ICEPIC, Linear Active Thermistor, Mindi, MiWi, MPASM, MPLIB, MPLINK, PICkit, PICDEM, PICDEM.net, PICLAB, PICtail, PowerCal, PowerInfo, PowerMate, PowerTool, REAL ICE, rLAB, rPICDEM, Select Mode, Smart Serial, SmartTel, Total Endurance, UNI/O, WiperLock and ZENA are trademarks of Microchip Technology Incorporated in the U.S.A. and other countries.

SQTP is a service mark of Microchip Technology Incorporated in the U.S.A.

All other trademarks mentioned herein are property of their respective companies.

© 2007, Microchip Technology Incorporated, Printed in the U.S.A., All Rights Reserved.

 Printed on recycled paper.

**QUALITY MANAGEMENT SYSTEM
CERTIFIED BY DNV
== ISO/TS 16949:2002 ==**

Microchip received ISO/TS-16949:2002 certification for its worldwide headquarters, design and wafer fabrication facilities in Chandler and Tempe, Arizona, Gresham, Oregon and Mountain View, California. The Company's quality system processes and procedures are for its PIC[®] MCUs and dsPIC DSCs, KEELOQ[®] code hopping devices, Serial EEPROMs, microperipherals, nonvolatile memory and analog products. In addition, Microchip's quality system for the design and manufacture of development systems is ISO 9001:2000 certified.



WORLDWIDE SALES AND SERVICE

AMERICAS

Corporate Office
2355 West Chandler Blvd.
Chandler, AZ 85224-6199
Tel: 480-792-7200
Fax: 480-792-7277
Technical Support:
<http://support.microchip.com>
Web Address:
www.microchip.com

Atlanta
Duluth, GA
Tel: 678-957-9614
Fax: 678-957-1455

Boston
Westborough, MA
Tel: 774-760-0087
Fax: 774-760-0088

Chicago
Itasca, IL
Tel: 630-285-0071
Fax: 630-285-0075

Dallas
Addison, TX
Tel: 972-818-7423
Fax: 972-818-2924

Detroit
Farmington Hills, MI
Tel: 248-538-2250
Fax: 248-538-2260

Kokomo
Kokomo, IN
Tel: 765-864-8360
Fax: 765-864-8387

Los Angeles
Mission Viejo, CA
Tel: 949-462-9523
Fax: 949-462-9608

Santa Clara
Santa Clara, CA
Tel: 408-961-6444
Fax: 408-961-6445

Toronto
Mississauga, Ontario,
Canada
Tel: 905-673-0699
Fax: 905-673-6509

ASIA/PACIFIC

Asia Pacific Office
Suites 3707-14, 37th Floor
Tower 6, The Gateway
Harbour City, Kowloon
Hong Kong
Tel: 852-2401-1200
Fax: 852-2401-3431

Australia - Sydney
Tel: 61-2-9868-6733
Fax: 61-2-9868-6755

China - Beijing
Tel: 86-10-8528-2100
Fax: 86-10-8528-2104

China - Chengdu
Tel: 86-28-8665-5511
Fax: 86-28-8665-7889

China - Fuzhou
Tel: 86-591-8750-3506
Fax: 86-591-8750-3521

China - Hong Kong SAR
Tel: 852-2401-1200
Fax: 852-2401-3431

China - Qingdao
Tel: 86-532-8502-7355
Fax: 86-532-8502-7205

China - Shanghai
Tel: 86-21-5407-5533
Fax: 86-21-5407-5066

China - Shenyang
Tel: 86-24-2334-2829
Fax: 86-24-2334-2393

China - Shenzhen
Tel: 86-755-8203-2660
Fax: 86-755-8203-1760

China - Shunde
Tel: 86-757-2839-5507
Fax: 86-757-2839-5571

China - Wuhan
Tel: 86-27-5980-5300
Fax: 86-27-5980-5118

China - Xian
Tel: 86-29-8833-7250
Fax: 86-29-8833-7256

ASIA/PACIFIC

India - Bangalore
Tel: 91-80-4182-8400
Fax: 91-80-4182-8422

India - New Delhi
Tel: 91-11-4160-8631
Fax: 91-11-4160-8632

India - Pune
Tel: 91-20-2566-1512
Fax: 91-20-2566-1513

Japan - Yokohama
Tel: 81-45-471-6166
Fax: 81-45-471-6122

Korea - Gumi
Tel: 82-54-473-4301
Fax: 82-54-473-4302

Korea - Seoul
Tel: 82-2-554-7200
Fax: 82-2-558-5932 or
82-2-558-5934

Malaysia - Penang
Tel: 60-4-646-8870
Fax: 60-4-646-5086

Philippines - Manila
Tel: 63-2-634-9065
Fax: 63-2-634-9069

Singapore
Tel: 65-6334-8870
Fax: 65-6334-8850

Taiwan - Hsin Chu
Tel: 886-3-572-9526
Fax: 886-3-572-6459

Taiwan - Kaohsiung
Tel: 886-7-536-4818
Fax: 886-7-536-4803

Taiwan - Taipei
Tel: 886-2-2500-6610
Fax: 886-2-2508-0102

Thailand - Bangkok
Tel: 66-2-694-1351
Fax: 66-2-694-1350

EUROPE

Austria - Wels
Tel: 43-7242-2244-39
Fax: 43-7242-2244-393

Denmark - Copenhagen
Tel: 45-4450-2828
Fax: 45-4485-2829

France - Paris
Tel: 33-1-69-53-63-20
Fax: 33-1-69-30-90-79

Germany - Munich
Tel: 49-89-627-144-0
Fax: 49-89-627-144-44

Italy - Milan
Tel: 39-0331-742611
Fax: 39-0331-466781

Netherlands - Drunen
Tel: 31-416-690399
Fax: 31-416-690340

Spain - Madrid
Tel: 34-91-708-08-90
Fax: 34-91-708-08-91

UK - Wokingham
Tel: 44-118-921-5869
Fax: 44-118-921-5820

Stand-Alone CAN Controller with SPI™ Interface 1		
1.0	Device Functionality	3
2.0	Can Message Frames	7
3.0	Message Transmission	15
4.0	Message Reception	21
5.0	Bit Timing	35
6.0	Error Detection	41
7.0	Interrupts	45
8.0	Oscillator	49
9.0	Modes of Operation	51
10.0	Register Map	55
11.0	SPI Interface	57
12.0	Electrical Characteristics	61
13.0	Packaging Information	65
Index		69
On-Line Support		71
Reader Response		72
Product Identification System		73
Worldwide Sales and Service		76

Компания «Life Electronics» занимается поставками электронных компонентов импортного и отечественного производства от производителей и со складов крупных дистрибьюторов Европы, Америки и Азии.

С конца 2013 года компания активно расширяет линейку поставок компонентов по направлению коаксиальный кабель, кварцевые генераторы и конденсаторы (керамические, пленочные, электролитические), за счёт заключения дистрибьюторских договоров

Мы предлагаем:

- Конкурентоспособные цены и скидки постоянным клиентам.
- Специальные условия для постоянных клиентов.
- Подбор аналогов.
- Поставку компонентов в любых объемах, удовлетворяющих вашим потребностям.
- Приемлемые сроки поставки, возможна ускоренная поставка.
- Доставку товара в любую точку России и стран СНГ.
- Комплексную поставку.
- Работу по проектам и поставку образцов.
- Формирование склада под заказчика.
- Сертификаты соответствия на поставляемую продукцию (по желанию клиента).
- Тестирование поставляемой продукции.
- Поставку компонентов, требующих военную и космическую приемку.
- Входной контроль качества.
- Наличие сертификата ISO.

В составе нашей компании организован Конструкторский отдел, призванный помогать разработчикам, и инженерам.

Конструкторский отдел помогает осуществить:

- Регистрацию проекта у производителя компонентов.
- Техническую поддержку проекта.
- Защиту от снятия компонента с производства.
- Оценку стоимости проекта по компонентам.
- Изготовление тестовой платы монтаж и пусконаладочные работы.



Тел: +7 (812) 336 43 04 (многоканальный)

Email: org@lifeelectronics.ru