

## Extension module - PSR-SPP- 24DC/TS/SDI8/SDIO4 - 2986041

Please be informed that the data shown in this PDF Document is generated from our Online Catalog. Please find the complete data in the user's documentation. Our General Terms of Use for Downloads are valid (<http://download.phoenixcontact.com>)



Module for I/O extension of the PSR-TRISAFE master module with 8 safe inputs and 4 safe, freely parameterizable channels (safe inputs or outputs), easy connection via PSR-TBUS DIN rail connector, width: 22.5 mm

The figure shows a version with a screw connection

### Why buy this product

- ✓ Flexible extension with safe inputs and outputs
- ✓ Narrow 22.5 mm housing
- ✓ 4 safe digital outputs or 4 additional digital inputs (that can be configured using SAFECNF)
- ✓ Multifunctional use for a wide range of safety functions
- ✓ Easy graphical configuration instead of complex programming
- ✓ Quick startup thanks to user-friendly simulation and test options
- ✓ Including PSR-TBUS plug-in connector (DIN rail connector) for adapting to the PSR-TRISAFE-M master module
- ✓ Up to Cat. 4/PL e according to ISO 13849-1, SILCL 3 according to IEC 62061, SIL 3 according to IEC 61508
- ✓ 8 safe digital inputs
- ✓ 2 alarm outputs or 2 clock outputs (that can be configured using SAFECNF)

### Key commercial data

Packing unit	0
Minimum order quantity	1
Catalog page	Page 31 (IF-2011)
GTIN	 4 046356 451369
Custom tariff number	85389091
Country of origin	GERMANY

### Technical data

#### Input data

Nominal input voltage UN	24 V DC (A1 / A2)
Input voltage range in reference to UN	0.85 ... 1.1
Typical input current at UN	100 mA
Maximum response time	< 30 ms
Bypassing voltage dips	20 ms
Recovery time	< 10 s

# Extension module - PSR-SPP- 24DC/TS/SDI8/SDIO4 - 2986041

## Technical data

### Input data

Protective circuit	Surge protection Suppressor diode
Status display	2 LEDs (green, red)
Number of safe inputs	12 (of which 4 can be configured as input or output)
Nominal voltage UN	24 V DC
Typical current consumption	4 mA
Signal level "0" signal	< 5 V
Signal level "1" signal	> 11 V
Permissible cable length	2000 m
Error detection time at 1-channel structure	< 1 s
Status display	12 LEDs (green)

### Output data

Output data	8 safe digital inputs 4 safe inputs 4 safe outputs 2 clock outputs 2 alarm outputs 4 LEDs (green)
Number of safe semiconductor outputs	4 (If the four parameterizable inputs/outputs are used as outputs)
Nominal voltage UN	24 V DC
Limiting continuous current	4x 0.5 A (see derating curve)
Max. capacitive load	1 µF (When using electromechanical components (e.g. safeguarding), the capacitive load can be disregarded.)
Max. inductive load	(A suitable and effective protective circuit is to be provided for inductive loads. A recommended measure is the use of free-wheeling diodes.)
Test pulses	< 1 ms
Cycle/alarm outputs	<p></p>
Number of outputs	2
Nominal voltage UN	24 V DC
Limiting continuous current	50 mA
Test pulses	~ 1 ms

### General data

Width	22.5 mm
Height	112 mm
Depth	114.5 mm
Ambient temperature (operation)	-20 °C ... 55 °C
Ambient temperature (storage/transport)	-20 °C ... 70 °C
Mounting position	Horizontal
Category according to EN 13849-1	4
Name	Air and creepage distances between the power circuits
Standards/regulations	DIN EN 50178
Rated surge voltage / insulation	0.8 kV / Basic isolation
Rated insulation voltage	50 V
Pollution degree	2
Surge voltage category	III
Housing material	Polyamide PA non-reinforced

# Extension module - PSR-SPP- 24DC/TS/SDI8/SDIO4 - 2986041

## Technical data

### General data

Interfaces	DIN rail TBUS for connection to the master module, supplied as standard
------------	---

### Connection data

Conductor cross section solid min.	0.2 mm <sup>2</sup>
Conductor cross section solid max.	1.5 mm <sup>2</sup>
Conductor cross section stranded min.	0.2 mm <sup>2</sup>
Conductor cross section stranded max.	1.5 mm <sup>2</sup>
Conductor cross section AWG/kcmil min.	24
Conductor cross section AWG/kcmil max	16
Stripping length	8 mm
Connection method	Spring-cage conn.

## Classifications

### eclass

eCl@ss 4.0	27371102
eCl@ss 4.1	27371102
eCl@ss 5.0	27371901
eCl@ss 5.1	27371901
eCl@ss 6.0	27371819

### etim

ETIM 2.0	EC001449
ETIM 3.0	EC001449
ETIM 4.0	EC001449

### unspsc

UNSPSC 6.01	30211901
UNSPSC 7.0901	39121501
UNSPSC 11	39121501
UNSPSC 12.01	39121501
UNSPSC 13.2	39121501

## Approvals

### Certificates

#### Certification

UL Listed / GOST / cUL Listed / cUL Listed

#### Certification EX

# Extension module - PSR-SPP- 24DC/TS/SDI8/SDIO4 - 2986041

## Approvals

Certification submitted

### Approval details

- UL Listed
- GOST
- cUL Listed
- cUL Listed

## Drawings

### Connection diagram

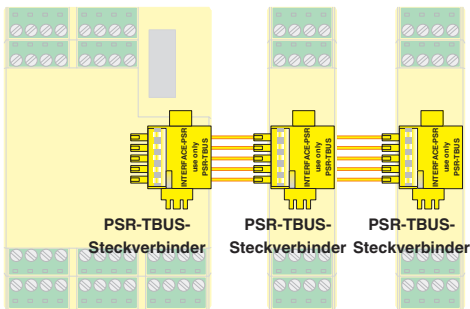

### Circuit diagram

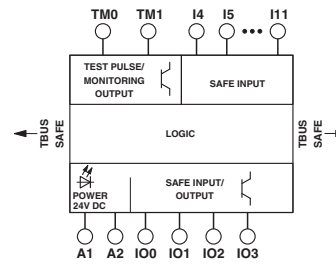

The TBUS connectors carry out the cross-wiring between the modules.

Компания «Life Electronics» занимается поставками электронных компонентов импортного и отечественного производства от производителей и со складов крупных дистрибьюторов Европы, Америки и Азии.

С конца 2013 года компания активно расширяет линейку поставок компонентов по направлению коаксиальный кабель, кварцевые генераторы и конденсаторы (керамические, пленочные, электролитические), за счёт заключения дистрибьюторских договоров

Мы предлагаем:

- Конкурентоспособные цены и скидки постоянным клиентам.
- Специальные условия для постоянных клиентов.
- Подбор аналогов.
- Поставку компонентов в любых объемах, удовлетворяющих вашим потребностям.
- Приемлемые сроки поставки, возможна ускоренная поставка.
- Доставку товара в любую точку России и стран СНГ.
- Комплексную поставку.
- Работу по проектам и поставку образцов.
- Формирование склада под заказчика.
- Сертификаты соответствия на поставляемую продукцию (по желанию клиента).
- Тестирование поставляемой продукции.
- Поставку компонентов, требующих военную и космическую приемку.
- Входной контроль качества.
- Наличие сертификата ISO.

В составе нашей компании организован Конструкторский отдел, призванный помогать разработчикам, и инженерам.

Конструкторский отдел помогает осуществить:

- Регистрацию проекта у производителя компонентов.
- Техническую поддержку проекта.
- Защиту от снятия компонента с производства.
- Оценку стоимости проекта по компонентам.
- Изготовление тестовой платы монтаж и пусконаладочные работы.



Тел: +7 (812) 336 43 04 (многоканальный)  
Email: [org@lifeelectronics.ru](mailto:org@lifeelectronics.ru)