

SERVER ON MODULE

conga-B7XD

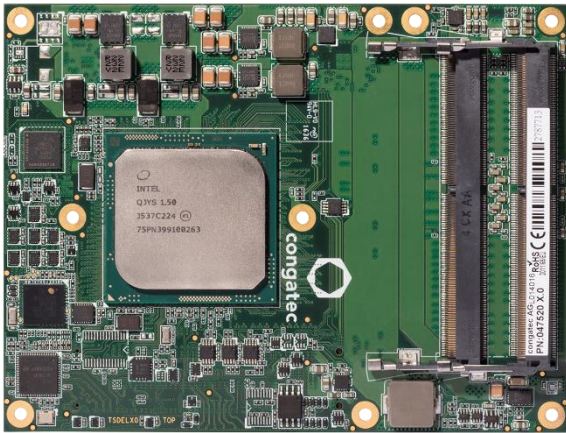

- COM Express Type 7
- Up to Intel® Xeon® D 1577 with 16 cores and 24 MB Cache
- 2x 10 Gigabit Ethernet KR Interface
- 32 PCI Express lanes
- Industrial grade variants
- Server Class Features (RAS, QoS, Virtualization, Security, Manageability)



Formfactor

COM Express® Basic, (95 x 125 mm) | Type 7 connector pinout

CPU

Commercial Versions

Intel® Xeon® D1577	1.3 GHz 2.1 GHz (boost)	16 Cores	24 MB cache	45W TDP
Intel® Xeon® D1567	2.1 GHz 2.7 GHz (boost)	12 Cores	18 MB cache	65W TDP
Intel® Xeon® D1548	2.0 GHz 2.6 GHz (boost)	8 Cores	12 MB cache	45W TDP
Intel® Xeon® D1527	2.2 GHz 2.7 GHz (boost)	4 Cores	6 MB cache	35W TDP
Intel® Pentium™ D1509	1.5 GHz 2.7 GHz (boost)	2 Cores	3 MB cache	19W TDP
Intel® Pentium™ D1508	2.2 GHz 2.6 GHz (boost)	2 Cores	3 MB cache	25W TDP

Industrial Versions

Intel® Xeon® D1559	1.5 GHz 2.1 GHz (boost)	12 Cores	18 MB cache	45W TDP
Intel® Xeon® D1539	1.6 GHz 2.2 GHz (boost)	8 Cores	12 MB cache	35W TDP
Intel® Xeon® D1529	1.3 GHz	4 Cores	6 MB cache	20W TDP
Intel® Pentium™ D1519	1.5 GHz 2.1 GHz (boost)	4 Cores	6 MB cache	25W TDP

DRAM

Dual channel DDR4 up to 2400 MT/s | 3x SO-DIMM | up to 3x 32 GByte (optionally with ECC support for Intel® Xeon®)

Chipset

Integrated in SoC

Ethernet

1x Intel I210AT /IT Gigabit Ethernet Controller | 2x 10GbE with KR interface support

I/O Interfaces

24x PCIe Gen3 | 8x PCIe Gen2 | 4x USB 3.0 | 4x USB 2.0 | 2x SATA III (6Gb/s) | LPC | SPI | I²C bus (fast mode 400 kHz, multi-master) | 2x UART | SMBus

congatec Board Controller

Multi Stage Watchdog | non-volatile User Data Storage | Manufacturing and Board Information | Board Statistics | I²C bus (fast mode, 400 kHz, multi-master) | Power Loss Control | Hardware Health Monitoring | POST Code redirection

Embedded BIOS Features

OEM Customization | Flash Update | based on AMI Aptio UEFI

Security

Trusted Platform Module (TPM 2.0)

Power Management

ACPI 5.0 with battery support

Operating Systems

Windows 64 bit OS

Microsoft® Windows Server 2016
 Microsoft® Windows Server 2012 R2
 Microsoft® Windows Server 2012
 Microsoft® Windows Server 2008 R2 SP1
 Microsoft® Windows 10 Enterprise
 Microsoft® Windows 8.1 64b
 Microsoft® Windows 7 64b

Open Source & Frameworks

RHEL 6.6 & 7.1
 SuSE 11 SP4 & 12 SP1
 Fedora 22
 Ubuntu 14.10
 CentOS 6.6 & 7.1
 FreeBSD

Other

RTS Hypervisor
 VMware
 Hyper-V
 Xen
 ESXI

Power Consumption

See user's guide for full details

Temperature

Industrial: Operating: -40 to +85°C Storage: -40 to +85°C
 Commercial: Operating: 0 to +60°C Storage: -40 to +85°C

Extended Temperature

Screening service on request :
 -25 to +80°C (burn-in & cold-soak)
 -40 to +85°C (burn-in & cold-soak)

Humidity

Operating: 10 - 90% r. H. non cond. Storage: 5 - 95% r. H. non cond.

Size

95 x 125 mm (3.74" x 4.92")

conga-B7XD | Block diagram

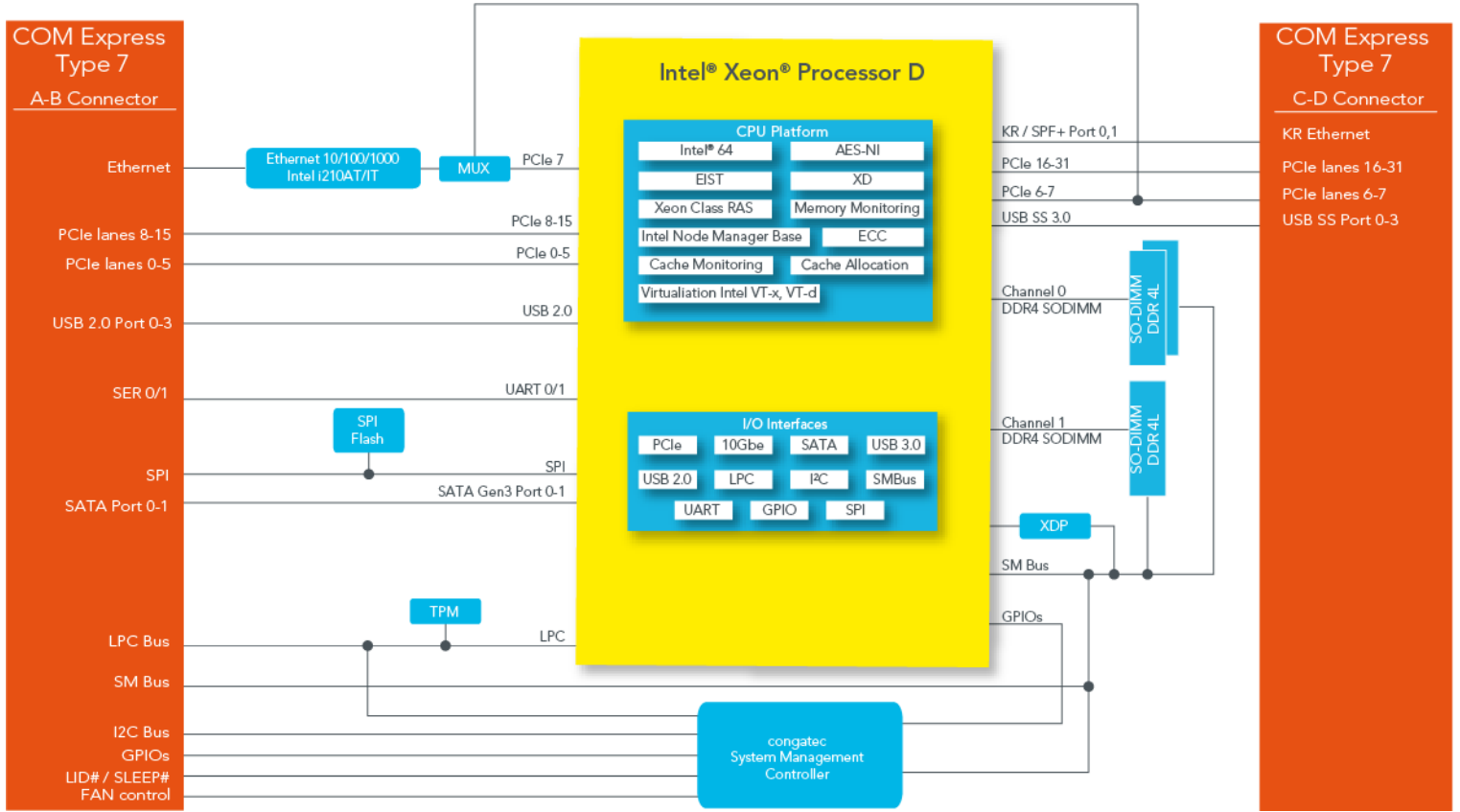

conga-B7XD | Order Information – COMe Modules

Article	PN	Description
conga-B7XD/X-D1577	047500	COM Express Type 7 Basic module with Intel® Xeon® D1577 processor with 16 Cores, 1.3GHz up to 2.1GHz core frequency, 24MB Cache and 2133 MT/s dual channel DDR4 memory interface for up to 96GB. Features two 10GbE KR interface ports. 45W TDP, commercial temperature range.
conga-B7XD/X-D1567	047501	COM Express Type 7 Basic module with Intel® Xeon® D1567 processor with 12 Cores, 2.1GHz up to 2.7GHz core frequency, 18MB Cache and 2133 MT/s dual channel DDR4 memory interface for up to 96GB. Features two 10GbE KR interface ports. 65W TDP, commercial temperature range.
conga-B7XD/X-D1548	047502	COM Express Type 7 Basic module with Intel® Xeon® D1548 processor with 8 Cores, 2.0GHz up to 2.6GHz core frequency, 12MB Cache with and 2400 MT/s dual channel DDR4 memory interface for up to 96GB. Features two 10GbE KR interface ports. 45W TDP, commercial temperature range.
conga-B7XD/X-D1527	047503	COM Express Type 7 Basic module with Intel® Xeon® D1527 processor with 4 Cores, 2.2GHz up to 2.7GHz core frequency, 6MB Cache with and 2133 MT/s dual channel DDR4 memory interface for up to 96GB. Features two 10GbE KR interface ports. 35W TDP, commercial temperature range.
conga-B7XD/P-D1509	047504	COM Express Type 7 Basic module with Intel® Pentium™ D1509 processor with 2 Cores, 1.5GHz core frequency, 3MB Cache and 1600 MT/s dual channel DDR4 memory interface for up to 96GB. 19W TDP, commercial temperature range.
conga-B7XD/P-D1508	047505	COM Express Type 7 Basic module with Intel® Pentium™ D1508 processor with 2 Cores, 2.2GHz up to 2.6GHz core frequency, 3MB Cache and 1866 MT/s dual channel DDR4 memory interface for up to 96GB. Features two 10GbE KR interface ports. 25W TDP, commercial temperature range.
conga-B7XD/i-X-D1559	047520	COM Express Type 7 Basic module with Intel® Xeon® D1559 processor with 12 Cores, 1.5GHz up to 2.1GHz core frequency, 18MB Cache and 2133 MT/s dual channel DDR4 memory interface for up to 96GB. Features two 10GbE KR interface ports. 45W TDP, industrial temperature range.
conga-B7XD/i-X-D1539	047521	COM Express Type 7 Basic module with Intel® Xeon® D1539 processor with 8 Cores, 1.6GHz up to 2.2GHz core frequency, 12MB Cache and 2133 MT/s dual channel DDR4 memory interface for up to 96GB. Features two 10GbE KR interface ports. 35W TDP, industrial temperature range.
conga-B7XD/i-X-D1529	047522	COM Express Type 7 Basic module with Intel® Xeon® D1529 processor with 4 Cores, 1.3GHz core frequency, 6MB Cache and 1600 MT/s dual channel DDR4 memory interface for up to 96GB. 20W TDP, industrial temperature range.
conga-B7XD/i-P-D1519	047523	COM Express Type 7 Basic module with Intel® Pentium™ D1519 processor with 4 Cores, 1.5GHz up to 2.1GHz core frequency, 6MB Cache and 2133 MT/s dual channel DDR4 memory interface for up to 96GB. Features two 10GbE KR interface ports. 25W TDP, industrial temperature range.

conga-B7XD | Order Information – Cooling Solutions

Article	PN	Description
B7XD/CSA-HP-T	047530	Standard active cooling solution for high performance COM Express Type 7 module conga-B7XD with integrated heat pipes, 70mm radial 12V PWM fan and 30mm overall heat sink height. All standoffs are M2.5mm threaded.
B7XD/CSA-HP-B	047531	Standard active cooling solution for high performance COM Express Type 7 module conga-B7XD with integrated heat pipes, 70mm radial 12V PWM fan and 30mm overall heat sink height. All standoffs are with 2.7mm bore hole.
B7XD/HSP-VC-T	047532	Standard heatspreader for high performance COM Express Type 7 module conga-B7XD with integrated vapor chamber. All standoffs are M2.5mm threaded.
B7XD/HSP-VC-B	047533	Standard heatspreader for high performance COM Express Type 7 module conga-B7XD with integrated vapor chamber. All standoffs are with 2.7mm bore hole.
B7XD/CSA-Cu-B	047535	Standard active cooling solution for low and mid range performance COM Express Type 7 module conga-B7XD with integrated copper plate, 70mm 12V radial FAN and 27mm overall heat sink height. Intended for modules with TDP up to 35W * Cu = Copper plate * B = 2.7mm Bore hole standoffs
B7XD/CSA-Cu-T	047536	Standard active cooling solution for low and mid range performance COM Express Type 7 module conga-B7XD with integrated copper plate, 70mm 12V radial FAN and 27mm overall heat sink height. Intended for modules with TDP up to 35W * Cu = Copper plate * T = M2.5 Threaded standoffs
B7XD/CSP-Cu-B	047537	Standard passive cooling solution for low and mid range performance COM Express Type 7 module conga-B7XD with integrated copper plate and 26mm overall heat sink height. Intended for modules with TDP up to 20W * Cu = Copper plate * B = 2.7mm Bore hole standoffs
B7XD/CSP-Cu-T	047538	Standard passive cooling solution for low and mid range performance COM Express Type 7 module conga-B7XD with integrated copper plate and 26mm overall heat sink height. Intended for modules with TDP up to 20W * Cu = Copper plate * T = M2.5 Threaded standoffs
B7XD/HSP-Cu-B	047539	Standard heatspreader for COM Express Type 7 module conga-B7XD with integrated copper plate and 11mm overall height. * Cu = Copper plate * B = 2.7mm Bore hole standoffs
B7XD/HSP-Cu-T	047540	Standard heatspreader for COM Express Type 7 module conga-B7XD with integrated copper plate and 11mm overall height. * Cu = Copper plate * T = M2.5 Threaded standoffs

conga-B7XD | Order Information - Accessories

Article	PN	Description
DDR4-SODIMM-2400 (4GB) TSDE	068728	DDR4 SODIMM memory module with 2400 MT/s and 4GB RAM for conga-B7XD
DDR4-SODIMM-2400 (8GB) TSDE	068724	DDR4 SODIMM memory module with 2400 MT/s and 8GB RAM for conga-B7XD
DDR4-SODIMM-2400 (16GB)	068792	DDR4 SODIMM memory module with 2400 MT/s and 16GB RAM
DDR4-SODIMM-2666 (32GB)	068806	DDR4 SODIMM memory module with 2666 MT/s and 32GB RAM
DDR4-SODIMM-2400 ECC (4GB) TSDE	068729	DDR4 ECC SODIMM memory module with 2400 MT/s and 4GB RAM for conga-B7XD
DDR4-SODIMM-2400 ECC (8GB) TSDE	068725	DDR4 ECC SODIMM memory module with 2400 MT/s and 8GB RAM for conga-B7XD
DDR4-SODIMM-2400 ECC (16GB)	068797	DDR4 ECC SODIMM memory module with 2400 MT/s and 16GB RAM
DDR4-SODIMM-2666 ECC (32GB)	068805	DDR4 ECC SODIMM memory module with 2666 MT/s and 32GB RAM
DDR4-SODIMM-2400 (4GB) / i-temp TSDE	068726	Industrial DDR4 SODIMM memory module with 2400 MT/s and 4GB RAM for conga-B7XD
DDR4-SODIMM-2400 (8GB) / i-temp TSDE	068722	Industrial DDR4 SODIMM memory module with 2400 MT/s and 8GB RAM for conga-B7XD
DDR4-SODIMM-2400 (16GB) / i-temp	068716	Industrial DDR4 SODIMM memory module with 2400 MT/s and 16GB RAM
DDR4-SODIMM-2666 (32GB) / i-temp	068807	Industrial DDR4 SODIMM memory module with 2666 MT/s and 32GB RAM
DDR4-SODIMM-2400 ECC (4GB) / i-temp TSDE	068727	Industrial DDR4 ECC SODIMM memory module with 2400 MT/s and 4GB RAM for conga-B7XD
DDR4-SODIMM-2400 ECC (8GB) / i-temp TSDE	068723	Industrial DDR4 ECC SODIMM memory module with 2400 MT/s and 8GB RAM for conga-B7XD
DDR4-SODIMM-2400 ECC (16GB) / i-temp	068719	Industrial DDR4 ECC SODIMM memory module with 2400 MT/s and 16GB RAM
DDR4-SODIMM-2666 ECC (32GB) / i-temp	068808	Industrial DDR4 ECC SODIMM memory module with 2666 MT/s and 32GB RAM
conga-X7EVAL	065420	Evaluation Carrier Board for COM Express Type 7 modules with up to four 10GbE SFP+ fiber/copper ports implemented via Intel Cortina 10GbE Phy's. The carrier features an Aspeed AST2500 Board Management Controller (BMC).

Компания «Life Electronics» занимается поставками электронных компонентов импортного и отечественного производства от производителей и со складов крупных дистрибьюторов Европы, Америки и Азии.

С конца 2013 года компания активно расширяет линейку поставок компонентов по направлению коаксиальный кабель, кварцевые генераторы и конденсаторы (керамические, пленочные, электролитические), за счёт заключения дистрибьюторских договоров

Мы предлагаем:

- Конкурентоспособные цены и скидки постоянным клиентам.
- Специальные условия для постоянных клиентов.
- Подбор аналогов.
- Поставку компонентов в любых объемах, удовлетворяющих вашим потребностям.
- Приемлемые сроки поставки, возможна ускоренная поставка.
- Доставку товара в любую точку России и стран СНГ.
- Комплексную поставку.
- Работу по проектам и поставку образцов.
- Формирование склада под заказчика.
- Сертификаты соответствия на поставляемую продукцию (по желанию клиента).
- Тестирование поставляемой продукции.
- Поставку компонентов, требующих военную и космическую приемку.
- Входной контроль качества.
- Наличие сертификата ISO.

В составе нашей компании организован Конструкторский отдел, призванный помогать разработчикам, и инженерам.

Конструкторский отдел помогает осуществить:

- Регистрацию проекта у производителя компонентов.
- Техническую поддержку проекта.
- Защиту от снятия компонента с производства.
- Оценку стоимости проекта по компонентам.
- Изготовление тестовой платы монтаж и пусконаладочные работы.



Тел: +7 (812) 336 43 04 (многоканальный)
Email: org@lifeelectronics.ru