

DATA SHEET

SC28L198

Octal UART for 3.3 V and 5 V supply
voltage

Product data sheet
Supersedes data of 1999 Jan 14

2006 Aug 10

Octal UART for 3.3 V and 5 V supply voltage

SC28L198

Table of Contents		
Description	2	
Uses	3	
Features	3	
Pin Configurations	4	
Pinout	4	
Pin Description	6	
Absolute Maximum Ratings	6	
Block Diagram	7	
Functional Description	7	
Conceptual Overview	7	
Host Interface	7	
Asynchronous bus cycle	7	
Synchronous bus cycle	7	
Timing Circuits	7	
Crystal Oscillator	8	
Sclk – System Clock	8	
Baud Rate Generator BRG	8	
BRG Counters (Used for random baud rate generation)	8	
Channel Blocks	8	
Character Recognition	8	
Interrupt Control	9	
Global Registers	9	
I/O Ports	9	
Detailed Descriptions	9	
Receiver and Transmitter	9	
Transmitter	9	
Status Bits	9	
Transmission of "break"	10	
1x and 16x modes, Transmitter	10	
Transmitter FIFO	10	
Receiver	10	
1x and 16x mode, Receiver	10	
Receiver Status Bits	10	
Receiver FIFO	11	
RxFIFO Status: Status reporting modes	11	
I/O ports	12	
General Purpose Pins	9	
Global Registers	8	
Character Recognition	8	
Xon Xoff Characters	12	
Multi-drop or Wake up or 9 bit mode	12	
Character Stripping	12	
Interrupt Arbitration and IRQN generation	12	
IACKN Cycle, Update CIR	13	
Polling	13	
Enabling and Activating Interrupt sources	13	
Setting Interrupt Priorities	13	
Modes of Operation	14	
Major Modes	14	
Minor Modes	15	
Watch-dog Timer Time-out Mode	15	
Wake Up Mode	15	
Xon/Xoff Operation	18	
REGISTER DEFINITIONS	18	
MR – Mode Registers	18	
UCIR – Update CIR	13	
General Purpose Output Pin Control	30	
Register Maps	31	
Register Map Summary	31	
Register Map Detail	32	
Reset Conditions	41	
Device Configuration after Hardware Reset or CRa cmd=x1F	41	
Cleared registers:	41	
Clears Modes for:	41	
Disables:	41	
Halts:	41	
Limitations:	41	
DC Electrical Specifications (5V)	42	
AC Electrical Characteristic (5V)	43	
DC Electrical Specifications (3.3V)	45	
AC Electrical Characteristics (3.3V)	46	
INDEX	52	

DESCRIPTION

The Philips 28L198 Octal UART is a single chip CMOS-LSI communications device that provides 8 full-duplex asynchronous channels with significantly deeper 16 byte FIFOs, Automatic in-band flow control using Xon/Xoff characters defined by the user and address recognition in the wake up mode. Synchronous bus interface is used for all communication between host and OCTART. It is fabricated using Philips 1.0 micron CMOS technology that combines the benefits of low cost, high density and low power consumption.

The operating speed of each receiver and transmitter can be selected independently from one of 22 fixed baud rates, a 16X clock derived from one of two programmable baud rate counters or one of three external 16X clocks (1 available at 1x clock rate). The baud rate generator and counter can operate directly from a crystal or from seven other external or internal clock inputs. The ability to independently program the operating speed of the receiver and transmitter makes the Octal UART particularly attractive for dual speed full duplex channel applications such as clustered terminal systems. The receivers and transmitters are buffered with FIFOs of 16 characters to minimize the potential for receiver overrun and to reduce interrupt overhead. In addition, a handshaking capability and in-band flow control are provided to disable a remote UART transmitter when the receiver buffer is full or nearly so.

To minimize interrupt overhead an interrupt arbitration system is included which reports the context of the interrupting UART via direct access or through the modification of the interrupt vector. The context of the interrupt is reported as channel number, type of device interrupting (receiver COS etc.) and, for transmitters or receivers, the fill level of the FIFO.

The Octal UART provides a power down mode in which the oscillator is stopped but the register contents are maintained. This results in reduced power consumption of several orders of magnitudes. The Octal UART is fully TTL compatible when operating from a single +5V power supply. Operation at 3.3 volts is maintained with CMOS interface levels.

The device also offered in a version which maintains TTL input and output levels while operating with a 3.3 volt power supply.

Octal UART for 3.3 V and 5 V supply voltage

SC28L198

Uses

Statistical Multiplexers
Data Concentrators

Packet-switching networks
Process Control
Building or Plant Control
Laboratory data gathering
ISDN front ends
Computer Networks
Point-of-Sale terminals

Automotive, cab and engine controls

Entertainment systems

MIDDI keyboard control music systems
Theater lighting control

Terminal Servers

Computer-Printer/Plotter links

FEATURES

- Single 3.3V and 5V power supply
- Eight Philips industry standard full duplex UART channels
- Sixteen byte receiver FIFOs for each UART
- Sixteen byte transmit FIFOs for each UART
- In band flow control using programmable Xon/Xoff characters
- Flow control using CTSN RTSN hardware handshaking
- Automatic address detection in multi-drop mode
- Three byte general purpose character recognition
- Fast data bus, 30 ns data bus release time, 125 ns bus cycle time
- Programmable interrupt priorities
- Automatic identification of highest priority interrupt pending
- Global interrupt and control registers ease setup and interrupt handling
- Vectored interrupts with programmable interrupt vector formats
 - Interrupt vector modified with channel number
 - Interrupt vector modified with channel number and channel type
 - Interrupt vector not modified
- IACKN and DACKN signal pins
- Watch dog timer for each receiver (64 receive clock counts)
- Programmable Data Formats:
 - 5 to 8 data bits plus parity
 - Odd, even force or no parity
 - 1, 1.5 or 2 stop bits
- Flexible baud rate selection for receivers and transmitters:
 - 22 fixed rates; 50 – 230.4K baud or 100 to 460.8K baud
 - Additional non-standard rates to 500K baud with internal generators
 - Two reload-counters provide additional programmable baud rate generation
 - External 1x or 16x clock inputs
 - Simplified baud rate selection
- 1 MHz 1x and 16x data rates full duplex all channels.
- Parity, framing and overrun error detection
- False start bit detection
- Line break detection and generation
- Programmable channel mode
 - Normal(full duplex)
 - Diagnostic modes
 - automatic echo
 - local loop back
 - remote loop back
- Four I/O ports per UART for modem controls, clocks, RTSN, I/O etc.
 - All I/O ports equipped with "Change of State Detectors"
- Two global inputs and two global outputs for general purpose I/O
- Power down mode
- On chip crystal oscillator, 2–8 MHz
- TTL input levels. Outputs switch between full V_{CC} and V_{SS}
- High speed CMOS technology
- 84 pin PLCC
- 100 pin LQFP

ORDERING INFORMATION

PACKAGES	V _{CC} = 3.3 V ± 10 %	V _{CC} = 5 V ± 10 %	DWG #
	Industrial ¹ –40 °C to +85 °C	Industrial ¹ –40 °C to +85 °C	
84-Pin Plastic Leaded Chip Carrier (PLCC)	SC28L198A1A	SC28L198A1A	SOT189-2
100-Pin Plastic Low-Profile Quad Flat Pack (LQFP)	SC28L198A1BE	SC28L198A1BE	SOT407-1

NOTES:

1. For availability, please contact factory.

Octal UART for 3.3 V and 5 V supply voltage

SC28L198

PLCC84 PIN CONFIGURATION

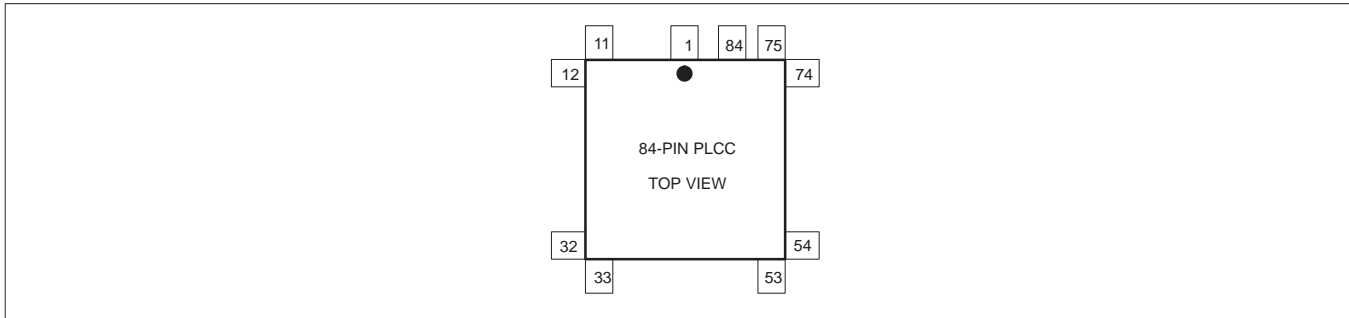

PLCC84 PINOUT

Pin	Function	Pin	Function	Pin	Function
1	V _{SS}	29	I/O1d	57	I/O2g
2	V _{CC}	30	I/O2d	58	I/O1g
3	CEN	31	I/O3d	59	I/O0g
4	W _{RN}	32	RxDd	60	RxDg
5	A2	33	V _{SS}	61	TxDg
6	A1	34	TxDd	62	V _{SS}
7	A0	35	RESETN	63	X1
8	DACKN	36	Gin0	64	X2
9	I/O0a	37	Gout0	65	TxDf
10	I/O1a	38	D0	66	I/O3f
11	RxDa	39	D1	67	I/O2f
12	RxDb	40	D2	68	I/O1f
13	I/O2a	41	D3	69	I/O0f
14	I/O3a	42	V _{SS}	70	TxD _e
15	TxDa	43	V _{CC}	71	I/O3 _e
16	I/O0b	44	D4	72	I/O2 _e
17	I/O1b	45	D5	73	I/O1 _e
18	I/O2b	46	D6	74	RxDf
19	I/O3b	47	D7	75	RxD _e
20	TxD _b	48	Gin1	76	I/O0 _e
21	I/O0 _c	49	I/O3 _h	77	IRQN
22	V _{SS}	50	I/O2 _h	78	A7
23	I/O1 _c	51	I/O1 _h	79	A6
24	I/O2 _c	52	I/O0 _h	80	A5
25	I/O3 _c	53	V _{SS}	81	A4
26	TxD _c	54	RxD _h	82	A3
27	RxD _c	55	TxD _h	83	IACKN
28	I/O0 _d	56	I/O3 _g	84	SCLK

Octal UART for 3.3 V and 5 V supply voltage

SC28L198

LQFP100 PIN CONFIGURATION

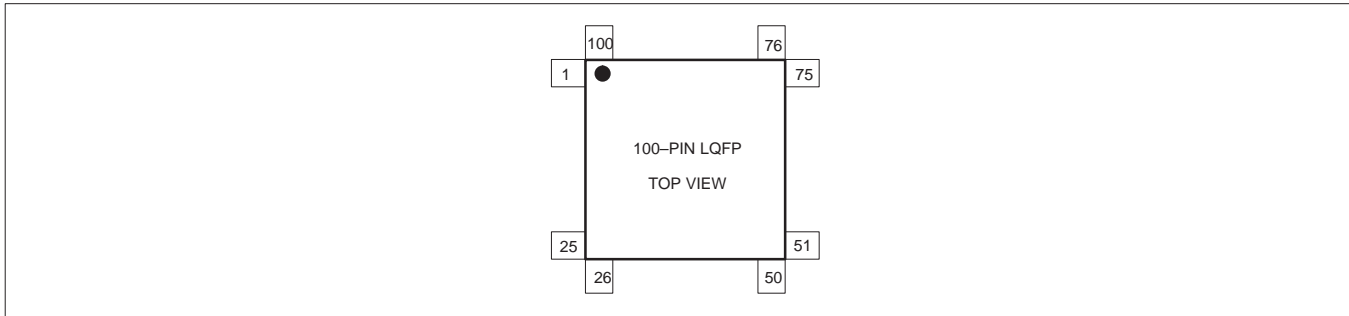

LQFP100 PINOUT

Pin	Function	Pin	Function	Pin	Function	Pin	Function
1	N/C	26	V _{SS}	51	N/C	76	N/C
2	RxD _b	27	TxD _d	52	N/C	77	RxD _e
3	I/O2 _a	28	RESETN	53	RxD _h	78	I/O0 _e
4	I/O3 _a	29	G _{IN} 0	54	TxD _h	79	IRQN
5	TxD _a	30	G _{OUT} 0	55	I/O3 _g	80	A7
6	I/O0 _b	31	D0	56	I/O2 _g	81	A6
7	I/O1 _b	32	D1	57	I/O1 _g	82	A5
8	I/O2 _b	33	D2	58	I/O0 _g	83	A4
9	I/O3 _b	34	D3	59	RxD _g	84	A3
10	TxD _b	35	V _{SS}	60	TxD _g	85	IACKN
11	I/O0 _c	36	V _{SS}	61	V _{SS}	86	Sclk
12	V _{SS}	37	V _{CC}	62	V _{SS}	87	V _{SS}
13	V _{SS}	38	V _{CC}	63	X1	88	V _{SS}
14	I/O1 _c	39	D4	64	X2	89	V _{CC}
15	I/O2 _c	40	D5	65	TxD _f	90	V _{CC}
16	I/O3 _c	41	D6	66	I/O3 _f	91	CEN
17	TxD _c	42	D7	67	I/O2 _f	92	W_RN
18	RxD _c	43	G _{IN} 1	68	I/O1 _f	93	A2
19	I/O0 _d	44	G _{OUT} 1	69	I/O0 _f	94	A1
20	I/O1 _d	45	I/O3 _h	70	TxD _e	95	JA0
21	I/O2 _d	46	I/O2 _h	71	I/O3 _e	96	DACKN
22	I/O3 _d	47	I/O1 _h	72	I/O2 _e	97	I/O0 _a
23	RxD _d	48	I/O0 _h	73	I/O1 _e	98	I/O1 _a
24	N/C	49	V _{SS}	74	RxD _f	99	RxD _a
25	N/C	50	V _{SS}	75	N/C	100	N/C

Octal UART for 3.3 V and 5 V supply voltage

SC28L198

Pin Description

MNEMONIC	TYPE	DESCRIPTION
Sclk	I	Host system clock. Used to time operations in the Host Interface and clock internal logic. Must be greater than twice the frequency of highest X1, Counter/Timer, TxC (1x) or RxC (1x) input frequency.
CEN	I	Chip select: Active low. When asserted, allows I/O access to OCTART registers by host CPU. W_RN signal indicates direction. (Must not be active in IACKN cycle)
A(7:0)	I	Address lines (A[6] is NOT used. See "Host Interface")
D(7:0)	I/O	8-bit bi-directional data bus. Carries command and status information between 28L198 and the host CPU. Used to convey parallel data for serial I/O between the host CPU and the 28L198
W_RN	I	Write Read not control: When high indicates that the host CPU will write to a 28L198 register or transmit FIFO. When low, indicates a read cycle. 0 = Read; 1 = Write
DACKN	O	Data Acknowledge: Active low. When asserted, it signals that the last transfer of the D lines is complete. Open drain.
IRQN	O	Interrupt Request: Active low. When asserted, indicates that the 28L198 requires service for pending interrupt(s). Open drain.
IACKN	I	Interrupt Acknowledge: Active low. When asserted, indicates that the host CPU has initiated an interrupt acknowledge cycle. (Do not use CEN in an IACKN cycle)
TD(a-h)	O	Transmit Data: Serial outputs from the 8 UARTs.
RD(a-h)	I	Receive Data: Serial inputs to the 8 UARTs
I/O0(a-h)	I/O	Input/Output 0: Multi-use input or output pin for the UART.
I/O1(a-h)	I/O	Input/Output 1: Multi-use input or output pin for the UART.
I/O2(a-h)	I/O	Input/Output 2: Multi-use input or output pin for the UART.
I/O3(a-h)	I/O	Input/Output 3: Multi-use input or output pin for the UART.
G _{IN} (1:0)	I	Global general purpose inputs, available to any/all channels.
G _{OUT} 0	O	Global general purpose outputs, available from any channel.
RESETN	I	Master reset: Active Low. Must be asserted at power up and may be asserted at other times to reset and re-start the system. See "Reset Conditions" at end of register map. Minimum width 10 SCLK.
X1/CCLK	I	Crystal 1 or Communication Clock: This pin may be connected to one side of a 2–8 MHz crystal. It may alternatively be driven by an external clock in this frequency range. Standard frequency = 3.6864 MHz
X2	O	Crystal 2: If a crystal is used, this is the connection to the second terminal. If a clock signal drives X1, this pin must be left unconnected.
Power Supplies	I	8 pins total 6 pins for V _{SS} , 2 pins for V _{CC}

NOTE: Many output pins will have very fast edges, especially when lightly loaded (less than 20 pf.) These edges may move as fast as 1 to 3 ns fall or rise time. The user must be aware of the possible generation of ringing and reflections on improperly terminated interconnections. See previous note on Sclk noise under pin assignments.

ABSOLUTE MAXIMUM RATINGS¹

SYMBOL	PARAMETER	RATING	UNIT
T _A	Operating ambient temperature range ²	See Note 3	°C
T _{STG}	Storage temperature range	–65 to +150	°C
V _{CC}	Voltage from V _{CC} to V _{SS} ⁴	–0.5 to +7.0	V
V _{SS}	Voltage from any pin to V _{SS}	–0.5 to V _{CC} + 0.5	V
P _D	Package Power Dissipation (PLCC)	3.78	W
P _D	Package Power Dissipation (LQFP)	2.08	W
	Derate above 25 °C (PLCC pkg.)	30	mW/°C
	Derate above 25 °C (LQFP pkg.)	17	mW/°C

NOTES:

- Stresses above those listed under Absolute Maximum Ratings may cause permanent damage to the device. This is a stress rating only and the functional operation of the device at these or any other conditions above those indicated in the Operation Section of this specification is not implied.
- For operating at elevated temperatures, the device must be derated based on +150 °C maximum junction temperature.
- Parameters are valid over specified temperature range. See ordering information table for applicable temperature range and operating supply range.
- This product includes circuitry specifically designed for the protection of its internal devices from damaging effects of excessive static charge.

Octal UART for 3.3 V and 5 V supply voltage

SC28L198

BLOCK DIAGRAM

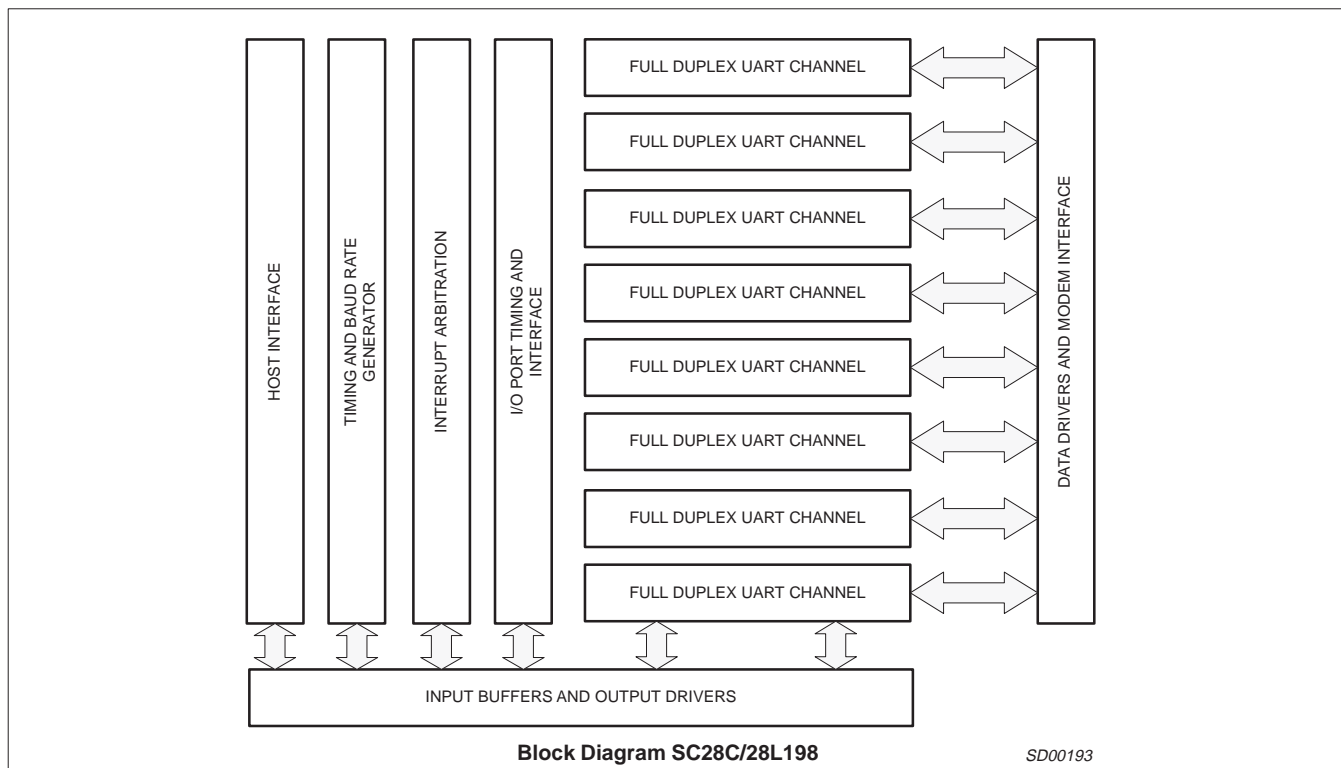

As shown in the block diagram, the Octal UART consists of: an interrupt arbiter, host interface, timing blocks and eight UART channel blocks. The eight channels blocks operate independently, interacting only with the timing, host I/F and interrupt blocks.

FUNCTIONAL DESCRIPTION

The SC28L198 is composed of several functional blocks:

- Synchronous host interface block
- A timing block consisting of a common baud rate generator making 22 industry standard baud rates and 2 16-bit counters used for non-standard baud rate generation
- 4 identical independent full duplex UART channel blocks
- Interrupt arbitration system evaluating 24 contenders
- I/O port control section and change of state detectors.

CONCEPTUAL OVERVIEW

Host Interface

The Host interface is comprised of the signal pins CEN, W/RN, IACKN, DACKN, IRQN Sclk and provides all the control for data transfer between the external and internal data buses of the host and the OCTART. The host interface operates in a synchronous mode with the system (Sclk) which has been designed for a nominal operating frequency of 33 MHz. The interface operates in either of two modes; **synchronous** or **asynchronous** to the Sclk. However the bus cycle within the OCTART **always** takes place in four Sclk cycles after CEN is recognized. These four cycles are the C1, C2, C3, C4 periods shown in the timing diagrams. DACKN always

occurs in the C4 time and occurs approximately 18 ns after the rising edge of C4.

Addressing of the various functions of the OCTART is through the address bus A(7:0). The 28L198 is compatible with the SC28L198 OCTAL UART in software and function. A[7], in a general sense, is used to separate the data portion of the circuit from the control portion.

Asynchronous bus cycle

The asynchronous mode requires one bus cycle of the chip select (CEN) for each read or write to the chip. No more action will occur on the bus after the C4 time until CEN is returned high.

Synchronous bus cycle

In the synchronous mode a read or write will be done every four cycles of the Sclk. CEN does not require cycling but must remain low to keep the synchronous accesses active. This provides a burst mode of access to the chip.

In both cases each read or write operation(s) will be completed in four (4) Sclk cycles. The difference in the two modes is only that the asynchronous mode will not begin another bus cycle if the CEN remains active after the four internal Sclk have completed. Internally the asynchronous cycle will terminate after the four periods of Sclk regardless of how long CEN is held active

In all cases the internal action will terminate at the withdrawal of CEN. Synchronous CEN cycles shorter than multiples of four Sclk cycles minus 1 Sclk and asynchronous CEN cycles shorter than four Sclk cycles may cause short read or write cycles and produce corrupted data transfers.

Timing Circuits

The timing block consists of a crystal oscillator, a fixed baud rate generator (BRG), a pair of programmable 16 bit register based

Octal UART for 3.3 V and 5 V supply voltage

SC28L198

counters. A buffer for the System Clock generates internal timing for processes not directly concerned with serial data flow.

Crystal Oscillator

The crystal oscillator operates directly from a crystal, tuned between 1.0 and 8.0 MHz, connected across the X1/CCLK and X2 inputs with a minimum of external components. BRG values listed for the clock select registers correspond to a 3.6864 MHz crystal frequency. Use of a 7.3728 MHz crystal will double the Communication Clock frequencies.

An external clock in the 100 KHz to 10 MHz frequency range may be connected to X1/CCLK. If an external clock is used instead of a crystal, X1/CCLK **must** be driven and X2 left floating. The X1 clock serves as the basic timing reference for the baud rate generator (BRG) and is available to the BRG timers. The X1 oscillator input may be left unused if the internal BRG is not used and the X1 signal is not selected for any counter input.

Sclk – System Clock

A clock frequency, within the limits specified in the electrical specifications, **must** be supplied for the system clock Sclk. To ensure the proper operation of internal controllers, the Sclk frequency provided, must be strictly greater than twice the frequency of X1 crystal clock, or any external 1x data clock input. The system clock serves as the basic timing reference for the host interface and other internal circuits.

Baud Rate Generator BRG

The baud rate generator operates from the oscillator or external X1/CCLK clock input and is capable of generating 22 commonly used data communications baud rates ranging from 50 to 230.4K baud. These common rates may be doubled (up to 460.8 and 500K baud) when faster clocks are used on the X1/X2 clock inputs. (See Receiver and Transmitter Clock Select Register descriptions.) All of these are available simultaneously for use by any receiver or transmitter. The clock outputs from the BRG are at 16X the actual baud rate.

BRG Counters (Used for random baud rate generation)

The two BRG Timers are programmable 16 bit dividers that are used for generating miscellaneous clocks. These clocks may be used by any or all of the receivers and transmitters in the Octart or output on the general purpose output pin GPO.

Each timer unit has eight different clock sources available to it as described in the BRG Timer Control Register. (BRGTCTR). Note that the timer run and stop controls are also contained in this register. The BRG Timers generate a symmetrical square wave whose half period is equal in time to the division of the selected BRG Timer clock source by the number loaded to the BRG Timer Reload Registers (BRGTRU and BRGTRL). Thus, the output frequency will be the clock source frequency divided by twice the value loaded to the BRGTRU and BRGTRL registers. This is the result of counting down once for the high portion of the output wave and once for the low portion.

Whenever these timers are selected via the receiver or transmitter Clock Select register their output will be configured as a 16x clock for the respective receiver or transmitter. Therefore one needs to program the timers to generate a clock 16 times faster than the data rate. The formula for calculating 'n', the number loaded to the BRGTRU and BRGTRL registers, is shown below.

$$n = \left(\frac{\text{BRG Timer Input frequency}}{2 \cdot 16 \cdot \text{desired baud rate}} \right) - 1$$

Note: 'n' may assume values of 0 and 1. In previous Philips data communications controllers these values were not allowed.

The BRG timer input frequency is controlled by the BRG Timer control register (BRGTCTR)

The frequency generated from the above formula will be at a rate 16 times faster than the desired baud rate. The transmitter and receiver state machines include divide by 16 circuits which provide the final frequency and provide various timing edges used in the qualifying the serial data bit stream. Often this division will result in a non-integer value; 26.3 for example. One may only program integer numbers to a digital divider. There for 26 would be chosen. If 26.7 was the result of the division then 27 would be chosen. This gives a baud rate error of 0.3/26.3 or 0.3/26.7. which yields a percentage error of 1.14% or 1.12% respectively; well within the ability of the asynchronous mode of operation.

One should be cautious about the assumed benign effects of small errors since the other receiver or transmitter with which one is communicating may also have a small error in the precise baud rate. In a "clean" communications environment using one start bit, eight data bits and one stop bit the total difference allowed between the transmitter and receiver frequency is approximately 4.6%. Less than eight data bits will increase this percentage.

Channel Blocks

There are eight channel blocks, each containing an I/O port control, a data format control, and a single full duplex UART channel consisting of a receiver and a transmitter with their associated 16 byte FIFOs. Each block has its own status register, interrupt status and interrupt mask registers and their interface to the interrupt arbitration system.

A highly programmable character recognition system is also included in each block. This system is used for the Xon/Xoff flow control and the multi-drop ("9 bit mode") address character recognition. It may also be used for general purpose character recognition.

Four I/O pins are provided for each channel. These pins are configured individually to be inputs or outputs. As inputs they may be used to bring external data to the bus, as clocks for internal functions or external control signals. Each I/O pin has a "Change of State" detector. The change detectors are used to signal a change in the signal level at the pin (Either 0 to 1 or 1 to 0). The level change on these pins must be stable for 25 to 50 Us (two edges of the 38.4 KHz baud rate clock) before the detectors will signal a valid change. These are typically used for interface signals from modems to the OCTART and from there to the host. See the description of the "UART channel" under detailed descriptions below.

Character Recognition

Character recognition is specific to each of the eight UARTs. Three programmable characters are provided for the character recognition for each channel. The three are general purpose in nature and may be set to only cause an interrupt or to initiate some rather complex operations specific to "Multi-drop" address recognition or in-band Xon/Xoff flow control.

Character recognition is accomplished via CAM memory. The Content Addressable Memory continually examines the incoming data stream. Upon the recognition of a control character appropriate bits are set in the Xon/Xoff Interrupt Status Register (XISR) and Interrupt Status Register (ISR). The setting of these bit(s) will initiate any of the automatic sequences or and/or an interrupt that may have enabled via the MR0 register.

The characters of the recognition system are not controlled by the software or hardware reset. They do not have a pre-defined "reset

Octal UART for 3.3 V and 5 V supply voltage

SC28L198

value". They may, however, be loaded by a "Gang White" or "Gang Load" command as described in the "Xon Xoff Characters" paragraph.

Note: Character recognition is further described in the *Minor Modes of Operation*.

Interrupt Control

The interrupt system determines when an interrupt should be asserted through an arbitration (or bidding) system. This arbitration is exercised over the several systems within the OCTART that may generate an interrupt. These will be referred to as "interrupt sources". There are 64 in all. In general the arbitration is based on the fill level of the receiver FIFO or the empty level of the transmitter FIFO. The FIFO levels are encoded into a four bit number which is concatenated to the channel number and source identification code. All of this is compared (via the bidding or arbitration process) to a user defined "threshold". When ever a source exceeds the numerical value of the threshold the interrupt will be generated.

At the time of interrupt acknowledge (IACKN) the source which has the highest bid (not necessarily the source that caused the interrupt to be generated) will be captured in a "Current Interrupt Register" (CIR). This register will contain the complete definition of the interrupting source: channel, type of interrupt (receiver, transmitter, change of state, etc.), and FIFO fill level. The value of the bits in the CIR are used to drive the interrupt vector and global registers such that controlling processor may be steered directly to the proper service routine. A single read operation to the CIR provides all the information needed to qualify and quantify the most common interrupt sources.

The interrupt sources for each channel are listed below.

- Transmit FIFO empty level for each channel
- Receive FIFO Fill level for each channel
- Change in break received status for each channel
- Receiver with error for each channel
- Change of state on channel input pins
- Receiver Watch-dog Time-out Event
- Xon/Xoff character recognition
- Address character recognition

Associated with the interrupt system are the interrupt mask register (IMR) and the interrupt status register (ISR) resident in each UART. Programming of the IMR selects which of the above sources may enter the arbitration process. Only the bidders in the ISR whose associated bit in the IMR is set to one (1) will be permitted to enter the arbitration process. The ISR can be read by the host CPU to determine all currently active interrupting conditions. For convenience the bits of the ISR may be masked by the bits of the IMR. Whether the ISR is read unmasked or masked is controlled by the setting of bit 6 in MR1.

Global Registers

The "Global Registers", 19 in all, are driven by the interrupt system. These are not real hardware devices. They are defined by the content of the CIR (Current Interrupt Register) as a result of an interrupt arbitration. In other words they are indirect registers contained in the Current Interrupt Register (CIR) which the CIR uses to point to the source and context of the OCTART sub circuit

presently causing an interrupt. The principle purpose of these "registers" is improving the efficiency of the interrupt service.

The global registers and the CIR update procedure are further described in the *Interrupt Arbitration* system

I/O Ports

Each of the eight UART blocks contains an I/O section of four ports. These ports function as a general purpose port section which services the particular UART they are associated with. External clocks are input and internal clocks are output through these ports. Each of the four pins has a change of state detector which will signal a change (0 to 1 or 1 to 0) at the pin. The change of state detectors are individually enabled and may be set to cause an interrupt.

These pins will normally be used for flow control hand-shaking and the interface to a modem. Their control is further described in *I/O Ports* section and the *I/OPCR* register.

DETAILED DESCRIPTIONS

RECEIVER AND TRANSMITTER

The Octal UART has eight full-duplex asynchronous receiver/transmitters. The operating frequency for the receiver and transmitter can be selected independently from the baud rate generator, the counter, or from an external input. Registers that are central to basic full-duplex operation are the mode registers (MR0, MR1 and MR2), the clock select registers (RxCSR and TxCSR), the command register (CR), the status register (SR), the transmit holding register (TxFIFO), and the receive holding register (Rx FIFO).

Transmitter

The transmitter accepts parallel data from the CPU and converts it to a serial bit stream on the TxD output pin. It automatically sends a start bit followed by the programmed number of data bits, an optional parity bit, and the programmed number of stop bits. The least significant bit is sent first. Each character is always "framed" by a single start bit and a stop bit that is 9/16 bit time or longer. If a new character is not available in the Tx FIFO, the TxD output remains high, the "marking" position, and the TxEMT bit in the SR is set to 1.

Transmitter Status Bits

The SR (Status Register, one per UART) contains two bits that show the condition of the transmitter FIFO. These bits are TxRDY and TxEMT. TxRDY means the Tx FIFO has space available for one or more bytes; TxEMT means The Tx FIFO is completely empty and the last stop bit has been completed. TxEMT can not be active without TxRDY also being active. These two bits will go active upon initial enabling of the transmitter. They will extinguish on the disable or reset of the transmitter.

Transmission resumes and the TxEMT bit is cleared when the CPU loads at least one new character into the Tx FIFO. The TxRDY will not extinguish until the Tx FIFO is completely full. The TxRDY bit will always be active when the transmitter is enabled and there is at least one open position in the Tx FIFO.

The transmitter is disabled by reset or by a bit in the command register (CR). The transmitter must be explicitly enabled via the CR before transmission can begin. Note that characters cannot be loaded into the Tx FIFO while the transmitter is disabled, hence it is necessary to enable the transmitter and then load the Tx FIFO. It is not possible to load the Tx FIFO and then enable the transmission.

Note the difference between transmitter disable and transmitter reset. The transmitter may be reset by a hardware or software. The

Octal UART for 3.3 V and 5 V supply voltage

SC28L198

software reset is issued through command 3x of the Command register (CR). The disable is done by setting the transmitter disable bit also in the command register. If the transmitter is disabled, it continues operating until the character currently being transmitted, if any, is completely sent, including the stop bit. When reset the transmitter stops immediately, drives the transmitter serial data output to a high level and discards any data in the TxFIFO.

Transmission of “break”s

Transmission of a break character is often needed as a synchronizing condition in a data stream. The “break” is defined as a start bit followed by all zero data bits by a zero parity bit (if parity is enabled) and a zero in the stop bit position. The forgoing is the minimum time to define a break. The transmitter can be forced to send a break (continuous low condition) by issuing a start break command via the CR. This command does not have any timing associated with it. Once issued the TxD output will be driven low (the spacing condition) and remain there until the host issues a command to “stop break” via the CR or the transmitter is issued a software or hardware reset. In normal operation the break is usually much longer than one character time.

1x and 16x modes, Transmitter

The transmitter clocking has two modes: 16x and 1x. Data is **always** sent at the 1x rate. However the logic of the transmitter may be operated with a clock that is 16 times faster than the data rate or at the same rate as the data i.e. 1x. All clocks selected internally for the transmitter (and the receiver) will be 16x clocks. Only when an external clock is selected may the transmitter logic and state machine operate in the 1x mode. The 1x or 16x clocking makes little difference in transmitter operation. (this is not true in the receiver) In the 16X clock mode the transmitter will recognize a byte in the TxFIFO within 1/16 to 2/16 bit time and thus begin transmission of the start bit; in the 1x mode this delay may be up to 2 bit times.

Transmitter FIFO

The transmitter buffer memory is a 16 byte by 8 bit ripple FIFO. The host writes characters to this buffer. This buffer accepts data only when the transmitter is enabled. The transmitter state machine reads them out in the order they were received and presents them to the transmitter shift register for serialization. The transmitter adds the required start, parity and stop bits as required the MR2 register programming. The start bit (always one bit time in length) is sent first followed by the least significant bit (LSB) to the most significant bit (MSB) of the character, the parity bit (if used) and the required stop bit(s).

Logic associated with the FIFO encodes the number of empty positions available in a four bit value. This value is concatenated with the channel number and type interrupt type identifier and presented to the interrupt arbitration system. The encoding of the “positions empty” value is always 1 less than the number of available positions. Thus, an empty TxFIFO will bid with the value or 15; when full it will not bid at all; one position empty bids with the value 0. A full FIFO will not bid since a character written to it will be lost

Normally a TxFIFO will present a bid to the arbitration system when ever it has one or more empty positions. The MR0[5:4] allow the user to modify this characteristic so that bidding will not start until one of four levels (empty, 3/4 empty, 1/2 empty, not full) have been reached. As will be shown later this feature may be used to make slight improvements in the interrupt service efficiency. A similar system exists in the receiver.

Receiver

The receiver accepts serial data on the RxD pin, converts the serial input to parallel format, checks for start bit, stop bit, parity bit (if any), framing error or break condition, and presents the assembled character and its status condition to the CPU via the Rx FIFO. Three status bits are FIFOed with each character received. The Rx FIFO is really 11 bits wide; eight data and 3 status. Unused FIFO bits for character lengths less than 8 bits are set to zero. It is important to note that receiver logic considers the entire message to be contained within the start bit to the stop bit. It is not aware that a message may contain many characters. The receiver returns to its idle mode at the end of each stop bit! As described below it immediately begins to search for another start bit which is normally, of course, immediately forthcoming.

1x and 16x mode, Receiver

The receiver operates in one of two modes; 1x and 16x. Of the two, the 16x is more robust and the preferred mode. Although the 1x mode may allow a faster data rate it does not provide for the alignment of the receiver 1x data clock to that of the transmitter. This strongly implies that the 1x clock of the remote transmitter is available to the receiver; the two devices are physically close to each other.

The 16x mode operates the receiver logic at a rate 16 times faster than the 1x data rate. This allows for validation of the start bit, validation of level changes at the receiver serial data input (RxD), and a stop bit length as short as 9/16 bit time. Of most importance in the 16x mode is the ability of the receiver logic to align the phase of the receiver 1x data clock to that of the transmitter with an accuracy of less than 1/16 bit time.

When the receiver is enabled (via the CR register) it begins looking for a high to low (mark to space) transition on the RxD input pin. If a transition is detected, an internal counter running at 16 times the data rate is reset to zero. If the RxD remains low and is still low when the counter reaches a count of 7 the receiver will consider this a valid start bit and begin assembling the character. If the RxD input returns to a high state the receiver will reject the previous high to low (mark to space) transition on the RxD input pin. This action is the “validation” of the start bit and also establishes the phase of the receiver 1x clock to that of the transmitter. The counter operating at 16x the data rate is the generator for the 1x data rate clock. With the phase of the receiver 1x clock aligned to the falling of the start bit (and thus aligned to the transmitter clock) AND with a valid start bit having been verified the receiver will continue receiving bits by sampling the RxD input on the rising edge of the 1x clock that is being generated by the above mentioned counter running 16 times the data rate. Since the falling edge of the 1x clock was aligned to falling edge of the start bit then the rising of the clock will be in the “center” of the bit cell.

This action will continue until a full character has been assembled. Parity , framing, and stop bit , and break status is then assembled and the character and its status bits are loaded to the Rx FIFO. At this point the receiver has finished its task for that character and will immediately begin the search for another start bit.

Receiver Status Bits

There are five (5) status bits that are evaluated with each byte (or character) received: received break, framing error, parity error, overrun error, and change of break. The first three are appended to each byte and stored in the Rx FIFO. The last two are not necessarily related to the a byte being received or a byte that is in the Rx FIFO. They are however developed by the receiver state machine

Octal UART for 3.3 V and 5 V supply voltage

SC28L198

. The "received break" will always be associated with a zero byte in the RxFIFO. It means that zero character was a break character and not a zero data byte. The reception of a break condition will always set the "change of break" (see below) status bit in the Interrupt Status Register(ISR).

A framing error occurs when a non zero character was seen and that character has a zero in the stop bit position.

The parity error indicates that the receiver generated parity was not the same as that sent by the transmitter.

The overrun error occurs when the RxFIFO is full, the receiver shift register is full and another start bit is detected. At this moment the receiver has 17 valid characters and the start bit of the 18th has been seen. At this point the host has approximately 7/16 bit time to read a byte from the RxFIFO or the overrun condition will be set and the 18th character will overrun the 17th and the 19th the 18th and so on until an open position in the RxFIFO is seen. The meaning of the overrun is that data has been lost. Data in the RxFIFO remains valid. The receiver will begin placing characters in the RxFIFO as soon as a position becomes vacant.

Note: Precaution must be taken when reading an overrun FIFO. There will be 16 valid characters. Data will begin loading as soon as the first character is read. The 17th. character will have been received as valid but it will not be known how many characters were lost between the two characters of the 16th. and 17th. reads of the RxFIFO

The "Change of break" means that either a break has been detected or that the break condition has been cleared. This bit is available in the ISR. The beginning of a break will be signaled by the break change bit being set in the ISR AND the received break bit being set in the SR. At the termination of the break condition only the change of break in the ISR will be set. After the break condition is detected the termination of the break will only be recognized when the RxD input has returned to the high state for two successive edges of the 1x clock; 1/2 to 1 bit time.

The receiver is disabled by reset or via CR commands. A disabled receiver will not interrupt the host CPU under any circumstance in the **normal** mode of operation. If the receiver is in the multi-drop or special mode, it will be partially enabled and thus may cause an interrupt. Refer to section on Wake-Up and minor modes and the register description for MR1 for more information.

Receiver FIFO

The receiver buffer memory is a 16 byte ripple FIFO with three status bits appended to each data byte. (The FIFO is then 16 11 bit "words"). The receiver state machine gathers the bits from the receiver shift register and the status bits from the receiver logic and writes the assembled byte and status bits to the RxFIFO. Logic associated with the FIFO encodes the number of filled positions for presentation to the interrupt arbitration system. The encoding is always 1 less than the number of filled positions. Thus, a full RxFIFO will bid with the value or 15; when empty it will not bid at all; one position occupied bids with the value 0. An empty FIFO will not bid since no character is available. Normally RxFIFO will present a bid to the arbitration system when ever it has one or more filled positions. The MR2[3:2 bits allow the user to modify this characteristic so that bidding will not start until one of four levels (one or more filled, 1/2 filled, 3/4 filled, full) have been reached. As will be shown later this feature may be used to make slight improvements in the interrupt service efficiency. A similar system exists in the transmitter.

RxFIFO Status: Status reporting modes

The description below applies to the upper three bits in the "Status Register" These three bits are not "in the status register"; They are part of the RxFIFO. The three status bits at the top of the RxFIFO are presented as the upper three bits of the status register included in each UART.

The error status of a character, as reported by a read of the SR (status register upper three bits) can be provided in two ways, as programmed by the error mode control bit in the mode register: "Character mode" or the "Block Mode". The block mode may be further modified (via a CR command) to set the status bits as the characters enter the FIFO or as they are read from the FIFO.

In the 'character' mode, status is provided on a character by character basis as the characters are read from the RxFIFO: the "status" applies only to the character at the top of the RxFIFO – The next character to be read

In the 'block' mode, the status provided in the SR for these three bits is the logical OR of the status for all characters coming to the top of the RxFIFO, since the last reset error command was issued. In this mode each of the status bits stored in the RxFIFO are passed through a latch as they are sequentially read. If any of the characters has an error bit set then that latch will set and remain set until reset with an "Reset Error" command from the command register or a receiver reset. The purpose of this mode is indicating an error in the data block as opposed to an error in a character

The latch used in the block mode to indicate "problem data" is usually set as the characters are read out of the RxFIFO. Via a command in the CR the latch may be configured to set the latch as the characters are pushed (loaded to) the RxFIFO. This gives the advantage of indicating "problem data" 16 characters earlier.

In either mode, reading the SR does not affect the RxFIFO. The RxFIFO is 'popped' only when the RxFIFO is read. Therefore, the SR should be read prior to reading the corresponding data character.

If the RxFIFO is full when a new character is received, that character is held in the receive shift register until a RxFIFO position is available. At this time there are 17 valid characters in the RxFIFO. If an additional character is received while this state exists, the contents of the RxFIFO are not affected: the character previously in the shift register is lost and the overrun error status bit, SR[4], will be set upon receipt of the start bit of the new (overrunning) character.

I/O ports

Each of the eight UARTs includes four I/O ports equipped with "change of state" detectors. The pins are individually programmable for an input only function or one of three output functions. These functions are controlled by the "I/O Port Configuration Register (I/OPCR)) They will normally be used for the RTSN–CTSN, DTR hardware signals, RxD or TxD input or output clocks or switch inputs as well as data out put from the I/OPIOR register.

It is important to note that the input circuits are always active. That is the signal on a port, whether it is derived from an internal or external source is always available to the internal circuits associated with an input on that port.

The "Change of State" (COS) detectors are sensitive to both a 1 to 0 or a 0 to 1 transition. The detectors are controlled by the internal 38.4 KHz baud rate and will signal a change when a transition has been stable for two rising edges of this clock. Thus a level on the I/O ports must be stable for 26 s to 52 s. Defining a port as an output will disable the COS detector at that port. The condition of

Octal UART for 3.3 V and 5 V supply voltage

SC28L198

the four I/O pins and their COS detectors is available at any time in the IPR (Input Port Register)

The control of data and COS enable for these ports is through the I/OPIOR register. This is a read/write register and gives individual control to the enabling of the change of state detectors and also to the level driven by I/O pins when programmed to drive the logic level written to the four lower bits of the I/OPIOR. A read of this register will indicate the data on the pin at the time of the read and the state of the enabled COS detectors.

General Purpose Pins

In addition to the I/O ports for each UART four other ports are provided which service the entire chip. Two are dedicated as inputs and one as an output. The G_{IN1} and G_{IN0} are the input pins; G_{OUT0} the output. These ports are multiplexed to nearly every functional unit in the chip. See the registers which describe the multitude of connections available for these pins. The G_{OUT0} pin is highly multiplexed output and is controlled by four (4) registers: GPOSR, GPOR, GPOC and GPOD. The G_{IN0} and G_{IN1} pins are available to the receivers and transmitters, BRG counters and the G_{OUT0} pin.

Global Registers

The "Global Registers", 19 in all, are driven by the interrupt system. These are not real hardware devices. They are defined by the content of the CIR (Current Interrupt Register) as a result of an interrupt arbitration. In other words they are indirect registers pointed to by the content of the CIR. The list of global register follows:

GIBCR	The byte count of the interrupting FIFO
GICR	Channel number of the interrupting channel
GITR	Type identification of interrupting channel
GRxFIFO	Pointer to the interrupting receiver FIFO
GTxFIFO	Pointer to the interrupting transmitter FIFO

A read of the GRxFIFO will give the content of the RxFIFO that presently has the highest bid value. The purpose of this system is to enhance the efficiency of the interrupt system. The global registers and the CIR update procedure are further described in the *Interrupt Arbitration* system

Character Recognition

The character recognition circuits are basically designed to provide general purpose character recognition. Additional control logic has been added to allow for Xon/Xoff flow control and for recognition of the address character in the multi-drop or "wake-up" mode. This logic also allows for the generation of an interrupts in either the general purpose recognition mode or the specific conditions mentioned above.

Xon Xoff Characters

The programming of these characters is usually done individually. However a method has been provided to write to all of registers in one operation. There are "Gang Load" and a "Gang Write" commands provided in the channel A Command Register. When these commands are executed all registers are programmed with the same characters. The "write" command loads a used defined character; the 'load' command loads the standard Xon/Xoff characters. Xon is 'x'11; Xoff 'x'13'. Any enabling of the Xon/Xoff functions will use the contents of the Xon and Xoff character registers as the basis on which recognition is predicated.

Multi-drop or Wake up or 9 bit mode

This mode is used to address a particular UART among a group connected to the same serial data source. Normally it is

accomplished by redefining the meaning of the parity bit such that it indicates a character as address or data. While this method is fully supported in the SC28L198 it also supports recognition of the character itself. Upon recognition of its address the receiver will be enabled and data pushed onto the Rx FIFO.

Further the Address recognition has the ability, if so programmed, to disable (not reset) the receiver when an address is seen that is not recognized as its own. The particular features of "Auto Wake and Auto Doze" are described in the detail descriptions below.

Note: Care should be taken in the programming of the character recognition registers. Programming x'00, for example, may result in a break condition being recognized as a control character. This will be further complicated when binary data is being processed.

Character Stripping

The MR0 register provides for stripping the characters used for character recognition. Recall that the character recognition may be conditioned to control several aspects of the communication. However this system is first a character recognition system. The status of the various states of this system are reported in the XISR and ISR registers. The character stripping of this system allows for the removal of the specified control characters from the data stream: two for the Xon/Xoff and one for the wake up. Via control in the MR0 register these characters may be discarded (stripped) from the data stream when the recognition system "sees" them or they may be sent on the Rx FIFO. Whether they are stripped or not the recognition will process them according to the action requested: flow control, wake up, interrupt generation, etc. Care should be exercised in programming the stripping option if noisy environments are encountered. If a normal character was corrupted to an Xoff character turned off the transmitter and it was then stripped, then the stripping action could make it difficult to determine the cause of transmitter stopping.

Interrupt Arbitration and IRQN generation

Interrupt arbitration is the process used to determine that an interrupt request should be presented to the host. The arbitration is carried out between the "Interrupt Threshold" and the "sources" whose interrupt bidding is enabled by the IMR. The interrupt threshold is part of the ICR (Interrupt Control Register) and is a value programmed by the user. The "sources" present a value to the interrupt arbiter. That value is derived from four fields: the channel number, type of interrupt source, FIFO fill level, and programmable value. . Only when one or more of these values exceeds the threshold value in the interrupt control register will the interrupt request (IRQN) be asserted.

Following assertion of the IRQN the host will either assert IACKN(Interrupt Acknowledge) or will use the command to "Update the CIR". At the time either action is taken the CIR will capture the value of the source that is prevailing in the arbitration process. (Call this value the winning bid)

The value in the CIR is the central quantity that results from the arbitration. It contains the identity of the interrupting channel, the type of interrupt in that channel (Rx, Tx, COS etc.) the fill levels of the Rx or Tx FIFOs and , in the case of an Rx interrupt an indicator of error data or good data. It also drives the Global Registers associated with the interrupt. **Most importantly it drives the modification of the Interrupt Vector.**

The arbitration process is driven by the Sclk. It scans the 10 bits of the arbitration bus at the Sclk rate developing a value for the CIR every 22 Sclk cycles. New arbitration values presented to the arbitration block during an arbitration cycle will be evaluated in the next arbitration cycle.

Octal UART for 3.3 V and 5 V supply voltage

SC28L198

For sources other than receiver and transmitters the user may set the high order bits of an interrupt source's bid value, thus tailoring the relative priority of the interrupt sources. The priority of the receivers and transmitters is controlled by the fill level of their respective FIFOs. The more filled spaces in the Rx FIFO the higher the bid value; the more empty spaces in the Tx FIFO the higher its priority. Channels whose programmable high order bits are set will be given interrupt priority higher than those with zeros in their high order bits, thus allowing increased flexibility. The transmitter and receiver bid values contain the character counts of the associated FIFOs as high order bits in the bid value. Thus, as a receiver's Rx FIFO fills, it bids with a progressively higher priority for interrupt service. Similarly, as empty space in a transmitter's Tx FIFO increases, its interrupt arbitration priority increases.

IACKN Cycle, Update CIR

When the host CPU responds to the interrupt, it will usually assert the IACKN signal low. This will cause the OCTART to generate an IACKN cycle in which the condition of the interrupting device is determined. When IACKN asserts, the last valid interrupt number is captured in the CIR. The value captured presents most of the important details of the highest priority interrupt at the moment the IACKN (or the "Update CIR" command) was asserted.

The Octal UART will respond to the IACKN cycle with an interrupt vector. The interrupt vector may be a fixed value, the content of the Interrupt Vector Register, or, when "Interrupt Vector Modification is enabled via ICR, it may contain codes for the interrupt type and/or interrupting channel. This allows the interrupt vector to steer the interrupt service **directly** to the proper service routine. The interrupt value captured in the CIR remains until another IACKN cycle occurs or until an "Update CIR" command is given to the OCTART. The interrupting channel and interrupt type fields of the CIR set the current "interrupt context" of the OCTART. The channel component of the interrupt context allows the use of Global Interrupt Information registers that appear at fixed positions in the register address map. For example, a read of the Global Rx FIFO will read the channel B Rx FIFO if the CIR interrupt context is channel b receiver. At another time read of the GRx FIFO may read the channel D Rx FIFO (CIR holds a channel D receiver interrupt) and so on. Global registers exist to facilitate qualifying the interrupt parameters and for writing to and reading from FIFOs without explicitly addressing them.

The CIR will load with x'00 if IACKN or Update CIR is asserted when the arbitration circuit is NOT asserting and interrupt. In this condition there is no arbitration value that exceeds the threshold value.

Polling

Many users prefer polled to interrupt driven service where there are a large number of fast data channels and/or the host CPU's other interrupt overhead is low. The Octal UART is functional in this environment.

The most efficient method of polling is the use of the "update CIR" command (with the interrupt threshold set to zero) followed by a read of the CIR. This dummy write cycle will perform the same CIR capture function that an IACKN falling edge would accomplish in an interrupt driven system. A subsequent read of the CIR, at the same address, will give information about an interrupt, if any. If the CIR contains 0s, no interrupt is awaiting service. If the value is non-zero, the fields of the CIR may be decoded for type, channel and character count information. Optionally, the global interrupt registers may be read for particular information about the interrupt

status or use of the global Rx D and Tx D registers for data transfer as appropriate. The interrupt context will remain in the CIR until another update CIR command or an IACKN cycle is initiated by the host CPU occurs. The CIR loads with x'00 if Update CIR is asserted when the arbitration circuit has NOT detected arbitration value that exceeds the threshold value.

Traditional methods of polling status registers may also be used. They of course are less efficient but give the most variable and quickest method of changing the order in which interrupt sources are evaluated and interrogated.

Enabling and Activating Interrupt sources

An interrupt source becomes enabled when its interrupt capability is set by writing to the Interrupt Mask Register, IMR. An interrupt source can never generate an IRQN or have its "bid" or interrupt number appear in the CIR unless the source has been enabled by the appropriate bit in an IMR.

An interrupt source is active if it is presenting its bid to the interrupt arbiter for evaluation. Most sources have simple activation requirements. The watch-dog timer, break received, Xon/Xoff or Address Recognition and change of state interrupts become active when the associated events occur and the arbitration value generated thereby exceeds the threshold value programmed in the ICR (Interrupt Control Register).

The transmitter and receiver functions have additional controls to modify the condition upon which the initiation of interrupt "bidding" begins: the TxINT and RxINT fields of the MR0 and MR2 registers. These fields can be used to start bidding or arbitration when the Rx FIFO is not empty, 50% full, 75% full or 100% full. For the transmitter it is not full, 50% empty, 75% empty and empty.

Example: To increase the probability of transferring the contents of a nearly full Rx FIFO, do not allow it to start bidding until 50% or 75% full. This will prevent its relatively high priority from winning the arbitration process at low fill levels. A high threshold level could accomplish the same thing, but may also mask out low priority interrupt sources that must be serviced. Note that for fast channels and/or long interrupt latency times using this feature should be used with caution since it reduces the time the host CPU has to respond to the interrupt request before receiver overrun occurs.

Setting Interrupt Priorities

The bid or interrupt number presented to the interrupt arbiter is composed of character counts, channel codes, fixed and programmable bit fields. The interrupt values are generated for various interrupt sources as shown in the table below: The value represented by the bits 9 to 3 in the table below are compared against the value represented by the "Threshold". The "Threshold", bits 6 to 0 of the ICR (Interrupt Control Register), is aligned such that bit 6 of the threshold is compared to bit 9 of the interrupt value generated by any of the sources. When ever the value of the interrupt source is greater than the threshold the interrupt will be generated.

The channel number arbitrates only against other channels. The threshold is not used for the channel arbitration. This results in channel D having the highest arbitration number. The decreasing order is H to A. If all other parts of an arbitration are equal then the channel number will determine which channel will dominate in the arbitration process

Octal UART for 3.3 V and 5 V supply voltage

SC28L198

Table 1. Interrupt Arbitration Priority

Type	B9	B8	B7	B6	B5	B4	B3	Bits 2:0
Receiver w/o error	RxFIFO Byte Count –1			0	0	1		Channel No
Receiver w/ error	RxFIFO Byte Count –1			1	0	1		Channel No
Transmitter	0	TxFIFO Byte Count –1			0	0		Channel No
Change of Break	Programmed Field			0	0	1	0	Channel No
Change of State	Programmed Field			0	1	1	0	Channel No
Xon/Xoff	Programmed Field			0	1	1	1	Channel No
Address Recognition	Programmed Field			0	0	1	1	Channel No
Receiver Watch-dog	RxFIFO Byte Count –1			As RxFIFO Above				Channel No
Threshold	Bits 6:0 of Interrupt Control Register							000

Note several characteristics of the above table in bits 6:3. These bits contain the identification of the bidding source as indicated below:

- x001 Receiver without error
- x101 Receiver with error
- xx00 Transmitter
- 0010 Change of Break
- 0110 Change of State on I/O Ports
- 0111 Xon/Xoff Event
- 0011 Address Recognition

The codes from bits 6:3 drive part of the interrupt vector modification and the Global Interrupt Type Register. The codes are unique to each source type and identify them completely. The channel numbering progresses from "a" to "d" as the binary numbers 000 to 011 and identify the interrupting channel uniquely. As the channels arbitrate "d" will have the highest bidding value and "a" the lowest

Note that the transmitter byte count is off-set from that of the receiver by one bit. This is to give the receiver more authority in the arbitration since an over-run receiver corrupts the message but an under-run transmitter is not harmful. This puts some constraints on how the threshold value is selected. If a threshold is chosen that has its MSB set to one then a transmitter can **never** generate an interrupt! Of course the counter point to this is the desire to set the interrupt threshold high so interrupts occur only when a maximum or near maximum number of characters may be transferred.

To give some control over this dilemma control bits have been provided in the MR0 and MR2 registers of each channel to individually control when a receiver or transmitter may interrupt. The use of these bits will prevent a receiver or a transmitter from entering the arbitration process even though its FIFO fill level is above that indicated by the threshold value set. The bits in the MR0 and MR2 register are named TxINT (MR0[5:4]) and RxINT (MR2[3:2])

The watch-dog is included in the table above to show that it affects the arbitration. It does not have an identity of its own. A barking watch-dog will prevent **any other source type** from entering the arbitration process except **enabled** receivers. The threshold is effectively set to zero when any watch-dog times out. The receivers arbitrate among themselves and the one with the highest fill level will win the process. Note that the receiver winning the bid may not be the one that caused the watch-dog to bark.

The fields labeled "Programmed Field" are the contents of the Bidding Control Registers, BCRs, for these sources. Setting these bits to high values can elevate the interrupt importance of the sources they represent to values almost as high as a full receiver. For example a COS event may be very important when it represents

the DSR (Data Set Ready) signal from the modem. In this case its arbitration value should be high. Once the DSR is recognized then its arbitration value could be reduced or turned off.

There is a single arbiter interrupt number that is not associated with any of the UART channels. It is the "Threshold Value" and is comprised of 7 bits from the Interrupt Control Register, ICR, and three zeros in the channel field. **It is only when one or more of the enabled interrupt sources generates a arbitration value larger than the threshold value that the IRQN will be asserted.** When the threshold bidding value is larger than any other bidding value then the IRQN will be withdrawn. In this condition the CIR will be loaded with if the IRQN or "Update CIR" command is asserted. Because the channels are numbered from 0 to 3 (A to D) channel 3 will win the bid when all other parts of the bid are equal.

Note: Based on this coding for the receiver and transmitter, a transmitter would not win a bid in the situation where the Count Field = 0 unless the threshold value is equal or less than 0000011. A single empty slot is left in the TxFIFO or a single filled slot in the RxFIFO will bid with a value of zero.

MODES OF OPERATION

Major Modes

Four major modes of operation (normal, auto echo, local loop back and remote loop back) are provided and are controlled by MR2[7:6]. Three of these may be considered diagnostic. See the MR2 register description.

The **normal** mode is the usual mode for data I/O operation. Most reception and transmission will use the normal mode.

In the **auto echo** mode, the transmitter automatically re-transmits any character captured by the channel's receiver. The receiver 1x clock is used for the transmitter. This mode returns the received data back to the sending station one bit time delayed from its departure. Receiver to host communication is normal. Host to transmitter communication has no meaning.

In the **local loop back** mode (used for diagnostic purposes) the transmitter is internally connected to the receiver input. The transmitter 1x clock used for the receiver. The RxD input pin is ignored and the transmitter TxD output pin is held high. This configuration allows the transmitter to send data to the receiver without any external parameters to affect the transmission of data. All status bits, interrupt conditions and processor interface operate normally. **It is recommended that this mode be used when initially verifying processor to UART interface.** The communication between the transmitter and receiver is entirely within the UART – it is essentially "talking to itself".

Octal UART for 3.3 V and 5 V supply voltage

SC28L198

The **remote loop back** mode (also used for diagnostic purposes) is similar to auto echo except that the characters are not sent to the local CPU, nor is the receiver status updated. The received data is sent directly to the transmitter where it is sent out on the TxD output. The received data is not sent to the receive FIFO and hence the host will not normally be participating in any diagnostics.

Minor Modes

The minor modes provide additional features within the major modes. In general the minor modes provide a reduction in the control burden and a less stringent interrupt latency time for the host processor. These modes could be invoked in all of the major modes.. However it may not be reasonable in many situations.

Watch-dog Timer Time-out Mode

Each receiver in the Octal UART is equipped with a watch-dog timer that is enabled by the "Watch-dog Timer Enable Register (WTER). The watch-dog "barks" (times out) if 64 counts of the receiver clock (64 bit times) elapse with no RxFIFO activity. RxFIFO events are a read of the RxFIFO or GRxFIFO, or the push of a received character into the RxFIFO. The timer resets when the (G)RxFIFO is read or if another character is pushed into the RxFIFO. The receiver watch-dog timer is included to allow detection of the very last character(s) of a received message that may be waiting in the RxFIFO, but are too few in number to successfully initiate an interrupt. The watch-dog timer is enabled for counting if the channel's bit in the Watch Dog Timer Control Register (WDTCR) is set. Note: a read of the GRxFIFO will reset the watch-dog timer of only the channel specified in the current interrupt context. Other watch-dogs are unaffected.

The watch-dog timer may generate an input to the interrupt arbiter if IMR[6] is set. The status of the Watch-dog timer can be seen as Bit 6 of the Interrupt Status Register, ISR[6]. When a Watch-dog timer that is programmed to generate an interrupt times out it enters the arbitration process. It will then only allow receivers to enter the enter the arbitration. All other sources are bidding sources are disabled. The receivers arbitrate only amongst themselves.. The receiver only interrupt mode of the interrupt arbiter continues until the last watch-dog timer event has been serviced. While in the receiver only interrupt mode, the control of the interrupt threshold level is also disabled. The receivers arbitrate only between themselves. The threshold value is ignored. The receiver with the most FIFO positions filled will win the bid. Hence the user need not reduce the bidding threshold level in the ICR to see the interrupt from a nearly empty RxFIFO that may have caused the watch-dog time-out.

Note: When any watch-dog times out only the receivers arbitrate. There is no increase in the probability of receiver being serviced causing the overrun of another receiver since they will still have priority based upon received character count.

The interrupt will be cleared automatically upon the push of the next character received or when the RxFIFO or GRxFIFO is read. The ICR is unaffected by the watch-dog time-out interrupt and normal interrupt threshold level sensing resumes after the last watch-dog timer event has been processed. If other interrupt sources are active, the IRQN pin may remain low.

Wake Up Mode

The SC28L198 provides two modes of this common asynchronous "party line" protocol: the new automatic mode with 3 sub modes and the default Host operated mode. The automatic mode has several sub modes (see below). In the full automatic the internal state machine devoted to this function will handle all operations

associated with address recognition, data handling, receiver enables and disables. In both modes the meaning of the parity bit is changed. It is often referred to as the A/D bit or the address/data bit. It is used to indicate whether the byte presently in the receiver shift register is an "address" byte or a "data" byte. "1" usually means address; "0" data.

Its purpose is to allow several receivers connected to the same data source to be individually addressed. Of course addressing could be by group also. Normally the "Master" would send an address byte to all receivers "listening" The receiver would then recognize its address and enable itself receiving the following data stream. Upon receipt of an address not its own it would then disable itself. As described below appropriate status bits are available to describe the operation.

Enabling the Wake Up mode

This mode is selected by programming bits MR1[4:3] to '11'. The sub modes are controlled by bits 6, 1, 0 in the MR0 register. Bit 6 controls the loading of the address byte to the RxFIFO and MR0[1:0] determines the sub mode as shown in the following table.

- | | |
|---------------|---|
| MR0[1:0] = 00 | Normal Wake Up Mode (default). Host controls operation via interrupts and commands written to the command register (CR). |
| MR0[1:0] = 01 | Auto wake. Enable receiver on address recognition for this station. Upon recognition of its assigned address, in the Auto Wake mode, the local receiver will be enabled and normal receiver communications with the host will be established. |
| MR0[1:0] = 10 | Auto Doze. Disable receiver on address recognition, not for this station. Upon recognition of an address character that is not its own, in the Auto Doze mode, the receiver will be disabled and the address just received either discarded or pushed to the RxFIFO depending on the programming of MR0[6]. |
| MR0[1:0] = 11 | Auto wake and doze. Both modes above. The programming of MR0[1:0] to 11 will enable both the auto wake and auto doze features. |

The enabling of the wake-up mode executes a partial enabling of the receiver state machine. Even though the receiver has been reset the wake up mode will over ride the disable and reset condition.

Normal Wake up (The default configuration)

In the default configuration for this mode of operation, a 'master' station transmits an address character followed by data characters for the addressed 'slave' station. The slave stations, whose receivers are normally disabled (not reset), examine the received data stream and interrupts the CPU (by setting RxRDY) only upon receipt of an address character. The CPU (host) compares the received address to its station address and enables the receiver if it wishes to receive the subsequent data characters. Upon receipt of another address character, the CPU may disable the receiver to initiate the process again

. A transmitted character consists of a start bit, the programmed number of data bits, an address/data (A/D) bit, and the programmed number of stop bits. The polarity of the transmitted A/D bit is selected by the CPU by programming bit MR1[2]. MR1[2] = 0 transmits a zero in the A/D bit position which identifies the corresponding data bits as **data**. MR1[2] = 1 transmits a one in the A/D bit position which identifies the corresponding data bits as an **address**. The CPU should program the mode register prior to loading the corresponding data bytes into the Tx FIFO.

Octal UART for 3.3 V and 5 V supply voltage

SC28L198

While in this mode, the receiver continuously looks at the received data stream, whether it is enabled or disabled. If disabled, it sets the RxRDY status bit and loads the character into the Rx FIFO if the received A/D bit is a one, but discards the received character if the received A/D bit is a zero. If the receiver is enabled, all received characters are transferred to the CPU via the Rx FIFO. In either case, the data bits are loaded into the data FIFO while the A/D bit is loaded into the status FIFO position normally used for parity error (SR[5]). Framing error, overrun error, and break detect operate normally whether or not the receiver is enabled.

Automatic operation, Wake Up & Doze

The automatic configuration for this mode uses on-board comparators to examine incoming address characters. Each UART channel may be assigned a unique address character. See the address register map and the description of the Address Recognition Character Register (ARCR). The device may be programmed to automatically awaken a sleeping receiver and/or disable an active receiver based upon address characters received. The operation of the basic receiver is the same as described above for the default mode of wake-up operation except that the CPU need not be interrupted to make a change in the receiver status.

Three bits in the Mode Register 0, (MR0), control the address recognition operation. MR0[6] controls the Rx FIFO operation of the received character; MR0[1:0] controls the wake up mode options. If MR0[6] is set the address character will be pushed onto the Rx FIFO, otherwise the character will be discarded. (The character is stripped from the data stream) The MR0[1:0] bits set the options as follows: A b'00 in this field, the default or power-on condition, puts the device in the default (CPU controlled) wake up mode of operation as described above. The auto-wake mode, enabled if MR0[0] is set, will cause the dedicated comparators to examine each address character presented by the receiver. If the received character matches the reference character in ARCR, the receiver will be enabled and all subsequent characters will be FIFOed until another address event occurs or the host CPU disables the receiver explicitly. The auto doze mode, enabled if MR0[1] is set, will automatically disable the receiver if an address is received that does not match the reference character in the ARCR.

The UART channel can present the address recognition event to the interrupt arbiter for IRQN generation. The IRQN generation may be masked by setting bit 5 of the Interrupt Mask Register, IMR. The bit level of an address recognition event is controlled by the Bidding Control Register, BCRA, of the channel.

Note: To ensure proper operation, the host CPU must clear any pending Address Recognition interrupt before enabling a disabled receiver operating in the Special or Wake-up mode. This may be accomplished via the CR commands to clear the Address Interrupt or by resetting the receiver.

Xon/Xoff Operation

Receiver Mode

Since the receiving FIFO resources in the Octal UART are limited, some means of controlling a remote transmitter is desirable in order to lessen the probability of receiver overrun. The Octal UART provides two methods of controlling the data flow. A hardware assisted means of accomplishing control, the so-called out-of-band flow control, and an in-band flow control method.

The out-of-band flow control is implemented through the CTSN-RTSN signaling via the I/O ports. The operation of these hardware handshake signals is described in the receiver and transmitter discussions.

In-band flow control is a protocol for controlling a remote transmitter by embedding special characters within the message stream, itself. Two characters, Xon and Xoff, which do not represent normal printable characters take on flow control definitions when the Xon/Xoff capability is enabled. Flow control characters received may be used to gate the channel transmitter on and off. This activity is referred to as Auto-transmitter mode. To protect the channel receiver from overrun, fixed fill levels (hardware set at 12 characters) of the Rx FIFO may be employed to automatically insert Xon/Xoff characters in the transmitter's data stream. This mode of operation is referred to as auto-receiver mode. Commands issued by the host CPU via the CR can simulate all these conditions.

Auto-transmitter mode

When a channel receiver pushes an Xoff character into the Rx FIFO, the channel transmitter will finish transmission of the current character and then stop transmitting. A transmitter so idled can be restarted by the receipt of an Xon character by the receiver, or by a hardware or software reset. The last option results in the loss of the un-transmitted contents of the Tx FIFO. When operating in this mode the Command Register commands for the transmitter are not effective.

While idle data may be written to the Tx FIFO and it continues to present its fill level to the interrupt arbiter and maintains the integrity of its status registers.

Use of '00' as an Xon/Xoff character is complicated by the Receiver break operation which pushes a '00' character on the Rx FIFO. The Xon/Xoff character detectors do not discriminate this case from an Xon/Xoff character received through the RxD pin.

Note: To be recognized as an Xon or Xoff character, the receiver must have room in the Rx FIFO to accommodate the character. An Xon/Xoff character that is received resulting in a receiver overrun does not effect the transmitter nor is it pushed into the Rx FIFO, regardless of the state of the Xon/Xoff transparency bit, MR0(7).

Note: Xon /Xoff characters

The Xon/Xoff characters with errors will be accepted as valid. The user has the option sending or not sending these characters to the FIFO. Error bits associated with Xon/Xoff will be stored normally to the receiver FIFO.

The channel's transmitter may be programmed to automatically transmit an Xoff character without host CPU intervention when the Rx FIFO fill level exceeds a fixed limit (12). In this mode, it will conversely transmit an Xon character when the Rx FIFO level drops below a second fixed limit (8). A character from the Tx FIFO that has been loaded into the TxD shift register will continue to transmit. Character(s) in the Tx FIFO that have not been popped are unaffected by the Xon or Xoff transmission. They will be transmitted after the Xon/Xoff activity concludes.

If the fill level condition that initiates Xon activity negates before the flow control character can begin transmission, the transmission of the flow control character will not occur, i.e. either of the following sequences may be transmitted depending on the timing of the FIFO level changes with respect to the normal character times:

Character	Xoff	Xon	Character
Character	Character		

Hardware keeps track of Xoff characters sent that are not rescinded by an Xon. This logic is reset by writing MR0(3) to '0'. If the user drops out of Auto-receiver mode while the XISR shows Xon as the last character sent, the Xon/Xoff logic will **not** automatically send the negating Xon.

Host mode

When neither the auto-receiver nor auto-transmitter modes are set, the Xon/Xoff logic is operating in the host mode. In host mode, all

Octal UART for 3.3 V and 5 V supply voltage

SC28L198

activity of the Xon/Xoff logic is initiated by commands to the CRx command forces the transmitter to disable exactly as though an Xoff character had been received by the RxFIFO. The transmitter will remain disabled until the chip is reset or the CR(7:3) = 10110 (Xoff resume) command is given. In particular, reception of an Xon or disabling or re-enabling the transmitter will **NOT** cause resumption of transmission. Redundant CRTXon/off commands, i.e. CRTXon CRTXon, are harmless, although they waste time. A CRTXon may be used to cancel a CRTXoff (and vice versa), but both may be transmitted depending on the timing with the transmit state machine. The kill CRTX command can be used to cleanly terminate any CRTX commands pending with the minimum impact on the transmitter.

Note: In **no** case will an Xon/Xoff character transmission be aborted. Once the character is loaded into the TX Shift Register, transmission continues until completion or a chip reset is encountered.

The kill CRTX command has no effect in either of the Auto modes.

Mode control

Xon/Xoff mode control is accomplished via the MR0. Bits 3 and 2 reset to zero resulting in all Xon/Xoff processing being disabled. If MR0[2] is set, the transmitter may be gated by Xon/Xoff characters received. If MR0[3] is set, the transmitter will transmit Xon and Xoff when triggered by attainment of fixed fill levels in the channel RxFIFO. The MR0[7] bit also has an Xon/Xoff function control. If this bit is set, a received Xon or Xoff character is not pushed into the RxFIFO. If cleared, the power-on and reset default, the received

Xon or Xoff character is pushed onto the RxFIFO for examination by the host CPU. The MR0(7) function operates regardless of the value in MR0(3:2)

Xon/Xoff Interrupts

The Xon/Xoff logic generates interrupts **only** in response to recognizing either of the characters in the XonCR or XoffCR (Xon or Xoff Character Registers). The transmitter activity initiated by the Xon/Xoff logic or any CR command does **not** generate an interrupt. The character comparators operate regardless of the value in MR0(3:2). Hence the comparators may be used as general purpose character detectors by setting MR0(3:2)='00' and enabling the Xon/Xoff interrupt in the IMR.

The Octal UART can present the **Xon/Xoff recognition event** to the interrupt arbiter for IRQN generation. The IRQN generation may be masked by setting bit 4 of the Interrupt Mask Register, IMR. The bid level of an Xon/Xoff recognition event is controlled by the Bidding Control Register X, BCRX, of the channel. The interrupt status can be examined in ISR[4]. If cleared, no Xon/Xoff recognition event is interrupting. If set, an Xon or Xoff recognition event has been detected. The X Interrupt Status Register, XISR, can be read for details of the interrupt and to examine other, non-interrupting, status of the Xon/Xoff logic. Refer to the XISR in the Register Descriptions.

The character recognition function and the associated interrupt generation is disabled on hardware or software reset.

Octal UART for 3.3 V and 5 V supply voltage

SC28L198

REGISTER DEFINITIONS

The operation of the Octal UART is programmed by writing control words into the appropriate registers. Operational feedback is provided via status registers which can be read by the host CPU. The Octal UART addressing is loosely divided, by the address bit A(7), into two parts:

1) That part which is concerned with the configuration of the chip interface and communication modes.

This part controls the elements of host interface setup, interrupt arbitration, I/O Port Configuration that part of the UART channel

definitions that do not change in normal data handling. This section is listed in the "Register Map, Control".

2) That part concerned with the transmission and reception of the bit streams.

This part concerns the data status, FIFO fill levels, data error conditions, channel status, data flow control (hand shaking). This section is listed in the "Register Map, Data".

The Global Configuration Control Register (GCCR) sets the type of bus cycle, interrupt vector modification and the power up or down mode.

Table 2. GCCR – Global Configuration Control Register

THIS IS A VERY IMPORTANT REGISTER! IT SHOULD BE THE FIRST REGISTER ADDRESSED DURING INITIALIZATION.

Bit 7	Bit 6	Bit 5:3	Bit 2:1	Bit 0
Reserved	Sync bus cycles	Reserved	IVC, Interrupt Vector Control	Power Down Mode
Reserved Must be set to 0	0 – async cycles 1 – Sync, non-pipe-lined cycle	Reserved Set to 0	00 – no interrupt vector 01 – IVR 10 – IVR + channel code 11 – IVR + interrupt type + channel code	0 – Device enabled 1 – Power down

GCCR(7): This bit is reserved for future versions of this device. If not set to zero most internal addressing will be disabled!

GCCR(6): Bus cycle selection

Controls the operation of the host interface logic. If reset, the power on/reset default, the host interface can accommodate arbitrarily long bus I/O cycles. If the bit is set, the Octal UART expects four Sclk cycle bus I/O operations similar to those produced by an i80386 processor in non-pipelined mode. The major differences in these modes are observed in the DACKN pin function. In Sync mode, no negation of CEN is required between cycles.

GCCR(2:1): Interrupt vector configuration

The IVC field controls if and how the assertion of IACKN (the interrupt acknowledge pin) will form the interrupt vector for the Octal UART. If b'00, no vector will be presented during an IACKN cycle. The bus will be driven high (xFF). If the field contains a b'01, the contents of the IVR, Interrupt Vector Register, will be presented as the interrupt vector without modification. If IVC = b'10, the channel code will replace the 3 LSBs of the IVR; if IVC = b'11 then a modified interrupt type and channel code replace the 5 LSBs of the IVR.

Note: The modified type field IVR(4:3) is:

10	Receiver w/o error
11	Receiver with error
01	Transmitter
00	All remaining sources

GCCR(0): Power down control

Controls the power down function. During power down the internal oscillator is disabled, interrupt arbitration and all data

transmission/reception activities cease, and all processing for input change detection, BRG counter/timers and Address/Xon./Xoff recognition is disabled.

Note: For maximum power savings it is recommended that all switching inputs be stopped and all input voltage levels be within 0.5 volt of the Vcc and Vss power supply levels.

To switch from the asynchronous to the synchronous bus cycle mode, a single write operation to the GCCR, terminated by a negation of the CEN pin, is required. This cycle may be 4 cycles long if the setup time of the CEN edge to Sclk can be guaranteed. The host CPU must ensure that a minimum of two Sclk cycles elapse before the initiation of the next (synchronous) bus cycle(s).

A hardware or software reset is recommended for the unlikely requirement of returning to the asynchronous bus cycling mode.

MR – Mode Registers

The user must exercise caution when changing the mode of running receivers, transmitters or BRG counter/timers. The selected mode will be activated immediately upon selection, even if this occurs during the reception or transmission of a character. It is also possible to disrupt internal controllers by changing modes at critical times, thus rendering later transmission or reception faulty or impossible. An exception to this policy is switching from auto-echo or remote loop back modes to normal mode. If the deselection occurs just after the receiver has sampled the stop bit (in most cases indicated by the assertion of the channel's RxRDY bit) and the transmitter is enabled, the transmitter will remain in auto-echo mode until the end of the transmission of the stop bit.

Octal UART for 3.3 V and 5 V supply voltage

SC28L198

Table 3. MR0– Mode Register 0

Bit 7	Bit 6	Bit 5:4	Bit 3:2	Bit 1:0
Xon/Xoff * transparency	Address Recognition * transparency	TxiINT	In-band flow control mode	Address Recognition control
0 – flow control characters received are pushed onto the RxFIFO 1 – flow control characters received are not pushed onto the RxFIFO	0 – Address characters received are pushed to RxFIFO 1 – Address characters received are not pushed onto the RxFIFO	TxFIFO interrupt level control 00 – empty 01 – 3/4 empty 10 – 1/2 empty 11 – not full	00 – host mode, only the host CPU may initiate flow control actions through the CR 01 – Auto Transmitter flow control 10 – Auto Receiver flow control 11 – Auto Receiver and Transmitter flow control	00 – none 01 – Auto wake 10 – Auto doze 11 – Auto wake and auto doze

* If these bits are not 0 the characters will be stripped regardless of bits (3:2) or (1:0)

MR0[7:6] – Control the handling of recognized Xon/Xoff or Address characters. If set, the character codes are placed on the RxFIFO along with their status bits just as ordinary characters are. If the character is not pushed onto the RxFIFO, its received status will be lost unless the receiver is operating in the block error mode, see MR1[5] and the general discussion on receiver error handling. Interrupt processing is not effected by the setting of these bits. See Character recognition section.

MR0[5:4] – Controls the fill level at which a transmitter begins to present its interrupt number to the interrupt arbitration logic. Use of a low fill level minimizes the number of interrupts generated and maximizes the number of transmit characters per interrupt cycle. It also increases the probability that the transmitter will go idle for lack of characters in the Tx FIFO.

MR0[3:2] – Controls the Xon/Xoff processing logic. Auto Transmitter flow control allows the gating of Transmitter activity by Xon/Xoff characters received by the Channel's receiver. Auto Receiver flow control causes the Transmitter to emit an Xoff

character when the RxFIFO has loaded to a depth of 12 characters. Draining the RxFIFO to a level of 8 or less causes the Transmitter to emit an Xon character. All transmissions require no host involvement. A setting other than b'00 in this field precludes the use of the command register to transmit Xon/Xoff characters.

Note: Interrupt generation in Xon/Xoff processing is controlled by the IMR (Interrupt Mask Register) of the individual channels. The interrupt may be cleared by a read of the XISR, the Xon/Xoff Interrupt Status Register. Receipt of a flow control character will always generate an interrupt if the IMR is so programmed. The MR0[3:2] bits have effect on the automatic aspects of flow control only, not the interrupt generation.

MR0[1:0] – This field controls the operation of the Address recognition logic. If the device is not operating in the special or “wake-up” mode, this hardware may be used as a general purpose character detector by choosing any combination except b'00. Interrupt generation is controlled by the channel IMR. The interrupt may be cleared by a read of the XISR, the Xon/Xoff Interrupt Status Register. See further description in the section on the Wake Up mode.

Table 4. MR1 – Mode Register 1

Bit 7	Bit 6	Bit 5	Bit 4:3	Bit 2	Bit 1:0
RxRTS Control	ISR Read Mode	Error Mode	Parity Mode	Parity Type	Bits per Character
0 – off 1 – on	0 – ISR unmasked 1 – ISR masked	0 = Character 1 = Block	00 – With Parity 01 – Force parity 10 – No parity 11 – Special Mode	0 = Even 1 = Odd	00 – 5 01 – 6 10 – 7 11 – 8

MR1[7]: Receiver Request to Send Control

This bit controls the deactivation of the RTSN output (I/O2) by the receiver. This output is asserted and negated by commands applied via the command register. MR1[7] = 1 causes RTSN to be automatically negated upon receipt of a valid start bit if the receiver FIFO is $\frac{1}{2}$ full or greater. RTSN is reasserted when an the FIFO fill level falls below $\frac{1}{2}$ full. This constitutes a change from previous members of Philips (Signets) UART families where the RTSN function triggered on FIFO full. This behavior caused problems with PC UARTs that could not stop transmission at the proper time. . The RTSN feature can be used to prevent overrun in the receiver, by using the RTSN output signal, to control the CTSN input of the transmitting device.

MR1[6]: Interrupt Status Masking

This bit controls the readout mode of the Interrupt Status Register, ISR. If set, the ISR reads the current status masked by the IMR, i.e. only interrupt sources enabled in the IMR can ever show a '1' in the ISR. If cleared, the ISR shows the current status of the interrupt source without regard to the Interrupt Mask setting.

MR1[5]: Error Mode Select

This bit selects the operating mode of the three FIFOed status bits (FE, PE, received break). In the character mode, status is provided on a character by character basis; the status applies only to the character at the bottom of the FIFO. In the block mode, the status provided in the SR for these bits is the accumulation (logical OR) of

Octal UART for 3.3 V and 5 V supply voltage

SC28L198

the status for all characters coming to the top of the FIFO, since the last reset error command was issued.

MR1[4:3]: Parity Mode Select

If 'with parity' or 'force parity' is selected, a parity bit is added to the transmitted character and the receiver performs a parity check on incoming data. MR1[4:3] = 11 selects the channel to operate in the special wake up mode.

MR1[2]: Parity Type Select

This bit sets the parity type (odd or even) if the 'with parity' mode is

programmed by MR1[4:3], and the polarity of the forced parity bit if the 'force parity' mode is programmed. It has no effect if the 'no parity' mode is programmed. In the special 'wake up' mode, it selects the polarity of the A/D bit. The parity bit is used to an address or data byte in the 'wake up' mode.

MR1[1:0]: Bits per Character Select

This field selects the number of data bits per character to be transmitted and received. This number does **not** include the start, parity, or stop bits.

Table 5. MR2 – Mode Register 2

The MR2 register provides basic channel setup control that may need more frequent updating.

Bits 7:6	Bit 5	Bit 4	Bit 3:2	Bit 1:0
Channel Mode	TxRTS Control	CTSN Enable Tx	RxINT	Stop Length
00 = normal 01 = Auto echo 10 = Local loop 11 = Remote loop	0 = No 1 = Yes	0 = No 1 = Yes	00 = RRDY 01 = Half Full 10 = 3/4 Full 11 = Full	00 = 1.0 01 = 1.5 10 = 2.0 11 = 9/16

MR2[7:6] – Mode Select

The Octal UART can operate in one of four modes: MR2[7:6] = b'00 is the normal mode, with the transmitter and receiver operating independently.

MR2[7:6] = b'01 places the channel in the automatic echo mode, which automatically re-transmits the received data. The following conditions are true while in automatic echo mode:

- Received data is re-clocked and re-transmitted on the TxD output.
- The receive clock is used for the transmitter.
- The receiver must be enabled, but the transmitter need not be enabled.
- The TxRDY and TxEMT status bits are inactive.
- The received parity is checked, but is not regenerated for transmission, i.e., transmitted parity bit is as received.
- Character framing is checked, but the stop bits are re-transmitted as received.
- A received break is echoed as received until the next valid start bit is detected

. CPU to receiver communication continues normally, but the CPU to transmitter link is disabled.

Two diagnostic modes can also be selected.

MR2[7:6] = b'10 selects local loop back mode. In this mode:

- The transmitter output is internally connected to the receiver input.
- The transmit clock is used for the receiver.
- The TxD output is held high.
- The RxD input is ignored.
- The transmitter must be enabled, but the receiver need not be enabled.
- CPU to transmitter and receiver communications continue normally.

The second diagnostic mode is the remote loop back mode, selected by MR2[7:6] = b'11. In this mode:

- Received data is re-clocked and re-transmitted on the TxD output.
- The receive clock is used for the transmitter.
- Received data is not sent to the local CPU, and the error status conditions are inactive.

The received parity is not checked and is not regenerated for transmission, i.e., the transmitted parity bit is as received.

The receiver must be enabled, but the transmitter need not be enabled.

Character framing is not checked, and the stop bits are re-transmitted as received.

A received break is echoed as received until the next valid start bit is detected.

MR2[5] – Transmitter Request to Send Control

This bit controls the deactivation of the RTSN output (I/O2) by the transmitter. This output is manually asserted and negated by appropriate commands issued via the command register. MR2[5] = 1 causes RTSN to be reset automatically one bit time after the characters in the transmit shift register and in the Tx FIFO (if any) are completely transmitted (includes the programmed number of stop bits if the transmitter is not enabled). This feature can be used to automatically terminate the transmission of a message as follows:

Program auto reset mode: MR2[5]= 1.

- Enable transmitter.
- Assert RTSN via command.
- Send message.

After the last character of the message is loaded to the Tx FIFO, disable the transmitter. Before disabling the transmitter be sure the Status Register TxEMT bit is NOT set (i.e., the transmitter is not underrun). The underrun condition is indicated by the TxEMT bit in the SR being set. The condition occurs immediately upon enabling the transmitter and persists until a character is loaded to the Tx FIFO. The Underrun condition will not be a problem as long as the controlling processor keeps up with the transmitter data flow. The proper operation of this feature assumes that the transmitter is busy (not underrun) when the disable is issued.

The last character will be transmitted and RTSN will be reset one bit time after the last stop bit.

NOTE: When the transmitter controls the RTSN pin, the meaning of the pin is COMPLETELY changed. It has nothing to do with the normal RTSN/CTSN "handshaking". It is usually used to mean "end of message" and to "turn the line around" in simplex communications.

MR2[4] – Clear to Send Control

The state of this bit determines if the CTSN input (I/O0) controls the operation of the transmitter. If this bit is 0, CTSN has no effect on

Octal UART for 3.3 V and 5 V supply voltage

SC28L198

the transmitter. If this bit is a 1, the transmitter checks the state of CTSN each time it is ready to begin sending a character. If it is asserted (low), the character is transmitted. If it is negated (high), the TxD output remains in the marking state and the transmission is delayed until CTSN goes low. Changes in CTSN, while a character is being transmitted, do not affect the transmission of that character. This feature can be used to prevent overrun of a remote receiver.

MR2[3:2] – RxINT control field

Controls when interrupt arbitration for a receiver begins based on RxFIFO fill level. This field allows interrupt arbitration to begin when the RxFIFO is full, 3/4 full, 1/2 full or when it contains at least 1

character.

MR2[1:0] – Stop Bit Length Select

This field programs the length of the stop bit appended to the transmitted character. Stop bit lengths of 9/16, 1, 1.5 and 2 bits can be programmed for character lengths of 6, 7, and 8 bits. For a character length of 5 bits, 1, 1.5 and 2 stop bits can be programmed. In all cases, the receiver only checks for a mark condition at the center of the first stop bit position (one bit time after the last data bit, or after the parity bit if parity is enabled). If an external 1X clock is used for the transmitter, MR2[1] = 0 selects one stop bit and MR2[1] = 1 selects two stop bits to be transmitted.

Table 6. RxCSR and TxCSR – Receiver and Transmitter Clock Select Registers

Both registers consist of single 5 bit field that selects the clock source for the receiver and transmitter, respectively. The unused bits in this register read b'111. The baud rates shown in the table below are based on the x1 crystal frequency of 3.6864MHz. The baud rates shown below will vary as the X1 crystal clock varies. For example, if the X1 rate is changed to 7.3728 MHz all the rates below will double.

Bits 7:5	Bits 4:0
Reserved	Transmitter/Receiver Clock select code, (see Clock Mux Table below)

Table 7. Data Clock Mux

CCLK maximum rate is 8MHz. Data clock rates will follow exactly the ratio of CCLK to 3.6864MHz.

Clock Select Code CSR (4:0)	Clock selection, CCLK = 3.6864 MHz	Clock Select Code	Clock selection, CCLK = 3.6864 MHz
00000	BRG – 50	10000	BRG – 19.2K
00001	BRG – 75	10001	BRG – 28.8K
00010	BRG – 150	10010	BRG – 38.4K
00011	BRG – 200	10011	BRG – 57.6K
00100	BRG – 300	10100	BRG – 115.2K
00101	BRG – 450	10101	BRG – 230.4K
00110	BRG – 600	10110	G _{IN} 0
00111	BRG – 900	10111	G _{IN} 1
01000	BRG – 1200	11000	BRG C/T 0
01001	BRG – 1800	11001	BRG C/T 1
01010	BRG – 2400	11010	Reserved
01011	BRG – 3600	11011	I/O2 rcvr, I/O3 xmit –16x
01100	BRG – 4800	11100	I/O2 rcvr, I/O3 xmit –1x
01101	BRG – 7200	11101	Reserved
01110	BRG – 9600	11110	Reserved
01111	BRG – 14.4K	11111	Reserved

Octal UART for 3.3 V and 5 V supply voltage

SC28L198

Table 8. CR – Command Register

CR is used to write commands to the Octal UART.

Bits 7:3	Bit 2	Bit 1	Bit 0
Channel Command codes see "Command Register Table"	Lock TxD and RxFIFO enables	Enable Tx	Enable Rx

CR[2] – Lock TxD and RxFIFO enables

If set, the transmitter and receiver enable bits, CR[1:0] are not significant. The enabled/disabled state of a receiver or transmitter can be changed only if this bit is at zero during the time of the write to the command register. **WRITES TO THE UPPER BITS OF THE CR WOULD USUALLY HAVE CR[2] AT 1** to maintain the condition of the receiver and transmitter. The bit provides a mechanism for writing commands to a channel, via CR[7:3], without the necessity of keeping track of or reading the current enable status of the receiver and transmitter.

CR[1] – Enable Transmitter

A one written to this bit enables operation of the transmitter. The TxRDY status bit will be asserted. When disabled by writing a zero to this bit, the command terminates transmitter operation and resets the TxRDY and TxEMT status bits. However, if a character is being transmitted or if characters are loaded in the TxFIFO when the transmitter is disabled, the transmission of the all character(s) is completed before assuming the inactive state.

CR[0] – Enable Receiver

A one written to this bit enables operation of the receiver. If not in the special wake up mode, this also forces the receiver into the search for start bit state. If a zero is written, this command terminates operation of the receiver immediately – a character being received will be lost. The command has no effect on the receiver status bits or any other control registers. If the special wake-up mode is programmed, the receiver operates even if it is disabled (see Wake-up Mode).

CR[7:3] – Miscellaneous Commands (See Table below)

The encoded value of this field can be used to specify a single command as follows:

00000	No command.
00001	Reserved
00010	Reset receiver. Resets the receiver as if a hardware reset had been applied. The receiver is disabled and the FIFO pointer is reset to the first location effectively discarding all unread characters in the FIFO.
00011	Reset transmitter. Resets the transmitter as if a hardware reset had been applied.
00100	Reset error status. Clears the received break, parity error, framing error, and overrun error bits in the status register (SR[7:4]). Used in character mode to clear overrun error status (although RB, PE and FE bits will also be cleared), and in block mode to clear all error status after a block of data has been received.
00101	Reset break change interrupt. Causes the break detect change bit in the interrupt status register (ISR[2]) to be cleared to zero.
00110	Start break. Forces the TxD output low (spacing). If the transmitter is empty, the start of the break condition will be delayed up to two bit times. If the transmitter is active, the break begins when transmission of the current character is completed. If there are characters in the TxFIFO, the start of break is delayed until those characters, or any others loaded after it have been transmitted (TxEMT must

00111	be true before break begins). The transmitter must be enabled to start a break.
01000	Stop break. The TxD line will go high (marking) within two bit times. TxD will remain high for one bit time before the next character, if any, is transmitted.
01001	Assert RTSN. Causes the RTSN output to be asserted (low). Negate RTSN. Causes the RTSN output to be negated (high). Note: The two commands above actually reset and set, respectively, the I/O2 or I/O1 pin associated with the I/OPIOR register.
01010	Reserved
01011	Reserved
01100	Reserved
01101	Block error status mode. Upon reset of the device or an individual receiver, the block mode of receiver error status accumulates as each character moves to the bottom of the RxFIFO, the position from which it will be read. In this mode of operation, the RxFIFO may contain a character with non-zero error status for some time. The status will not reflect the error character's presence until it is ready to be popped from the RxFIFO. Command 01101 allows the error status to be updated as each character is pushed into the RxFIFO. This allows the earliest detection of a problem character, but complicates the determination of exactly which character is causing the error. This mode of block error accumulation may be exited only by resetting the chip or the individual receiver.
01111	Reserved.
10000	Transmit an Xon Character
10001	Transmit an Xoff Character
10010	Reserved for channels b-h, for channel a: enables a Gang Write of Xon Character Registers. After this command is issued, a write to the channel A Xon Character Register will result in a write to all channel's Xon character registers. This command provides a mechanism to initialize all the Xon Character registers with one write. A write to channel A Xon Character Register returns the Octal UART to the individual Xon write mode.
10011	Reserved for channels b-h, for channel a: enables Gang Write of Xoff Character Registers. After this command is issued, a write to the channel A Xoff Character Register will result in a write to all channel's Xoff character registers. This command provides a mechanism to initialize all the Xoff Character registers with one write. A write to channel A Xoff Character Register returns the Octal UART to the individual Xoff write mode.
Note: Gang writing of Xon/Xoff Character Commands: Issuing command causes the next write to Xon/Xoff Character Register A to effect a simultaneous write into the other 3 Xon/Xoff character registers. After the Xon/Xoff Character Register A is written, the 28L198 returns to individual write mode for the Xon/Xoff Character Registers. Other intervening reads and writes are ignored. The device resets to individual write mode.	
10100	Reserved for channels b-h, for channel a: executes a Gang Load of Xon Character Registers. Executing this command causes a write of the value x'11 to all channel's Xon character registers. This command provides a mechanism to initialize all the Xon Character registers to a default value with one write. Execution of this command is immediate and does not effect the timing of subsequent host I/O operations.
10101	Reserved for channels b-h, for channel a: executes a Gang Load of Xoff Character Registers. Executing this command causes a write of the value x'13 to all channel's Xoff character registers. This command provides a

Octal UART for 3.3 V and 5 V supply voltage

SC28L198

	mechanism to initialize all the Xoff Character registers to a default value with one write. Execution of this command is immediate and does not effect the timing of subsequent host I/O operations.		flow control character is not yet loaded into the TxD Shift Register. If there is no character waiting for transmission or if its transmission has already begun, then this command has no effect.
10110	Xoff resume command (CRXoffre; not active in "Auto-Transmit Mode"). A command to cancel a previous Host Xoff command. Upon receipt, the channel's transmitter will transfer a character, if any, from the Tx FIFO and begin transmission.	11001–11011	Reserved
10111	Host Xoff command (CRXoff). This command allows tight host CPU control of the flow control of the channel transmitter. When interrupted for receipt of an Xoff character by the receiver, the host may stop transmission of further characters by the channel transmitter by issuing the Host Xoff command. Any character that has been transferred to the TxD shift register will complete its transmission, including the stop bit.	11011	Reset Address Recognition Status. This command clears the interrupt status that was set when an address character was recognized by a disabled receiver operating in the special mode.
11000	Cancel Host transmit flow control command. Issuing this command will cancel a previous transmit command if the	11100–11101	Reserved
		11110	Resets all UART channel registers. This command provides a means to zero all the UART channels that are not reset to x'00 by a reset command or a hardware reset.
		11111	Reserved for channels b-h, for channel a: executes a chip wide reset. Executing this command in channel a is equivalent to a hardware reset with the RESETN pin. Executing in channel b-h, has no effect.

Table 9. Command Register Code

Commands x'12, x'13, x'14, x'15, x'1f (marked with*) are global and exist only in channel A's register space.

Channel Command Code	Channel Command	Channel Command Code	Channel Command
CR[7:3]	Description	CR[7:3]	Description
00000	NOP	10000	Transmit Xon
00001	Reserved	10001	Transmit Xoff
00010	Reset Receiver	10010	Gang Write Xon Character Registers *
00011	Reset Transmitter	10011	Gang Write Xoff Character Registers *
00100	Reset Error Status	10100	Gang Load Xon Character Registers DC1 *
00101	Reset Break Change Interrupt	10101	Gang Load Xoff Character Registers DC3 *
00110	Begin Transmit Break	10110	Xoff Resume Command
00111	End Transmit Break	10111	Host Xoff Command
01000	Assert RTSN (I/O2 or I/O1)	11000	Cancel Transmit X Char command
01001	Negate RTSN (I/O2 or I/O1)	11001	Reserved
01010	Set time-out mode on	11010	Reserved
01011	Reserved	11011	Reset Address Recognition Status
01100	Set time-out mode off	11100	Reserved
01101	Block Error Status configure	11101	Reserved
01110	Reserved	11110	Reset All UART channel registers
01111	Reserved	11111	Reset Device *

Table 10. SR – Channel Status Register

Bit 7	Bit 6	Bit 5	Bit 4	Bit 3	Bit 2	Bit 1	Bit 0
Received Break	Framing Error	Parity Error	Overrun Error	TxE _{MT}	TxR _{DY}	RxF _{FULL}	RxR _{DY}
0 – No 1 – Yes	0 – No 1 – Yes	0 – No 1 – Yes	0 – No 1 – Yes	0 – No 1 – Yes	0 – No 1 – Yes	0 – No 1 – Yes	0 – No 1 – Yes

SR[7] – Received Break

This bit indicates that an all zero character of the programmed length has been received without a stop bit. Only a single FIFO position is occupied when a break is received; further entries to the FIFO are inhibited until the RxD line returns to the marking state for at least one half bit time (two successive edges of the internal or external 1x clock). When this bit is set, the change in break bit in the ISR (ISR[2]) is set. ISR[2] is also set when the end of the break condition, as defined above, is detected. The break detect circuitry

is capable of detecting breaks that originate in the middle of a received character. However, if a break begins in the middle of a character, it must last until the end of the next character in order for it to be detected.

SR[6] – Framing Error (FE)

This bit, when set, indicates that a stop bit was not detected when the corresponding data character in the FIFO was received. The stop bit check is made in the middle of the first stop bit position.

Octal UART for 3.3 V and 5 V supply voltage

SC28L198

SR[5] – Parity Error (PE)

This bit is set when the 'with parity' or 'force parity' mode is programmed and the corresponding character in the FIFO was received with incorrect parity. In the special 'wake up mode', the parity error bit stores the received A/D bit.

SR[4] – Overrun Error (OE)

This bit, when set, indicates that one or more characters in the received data stream have been lost. It is set upon receipt of a new character when the RxFIFO is full and a character is already in the receive shift register waiting for an empty FIFO position. When this occurs, the character in the receive shift register (and its break detect, parity error and framing error status, if any) is lost. This bit is cleared by a reset error status command.

SR[3] – Transmitter Empty (TxEMT)

This bit is set when the transmitter underruns, i.e., both the TxFIFO and the transmit shift register are empty.

It is set after transmission of the last stop bit of a character, if no character is in the TxFIFO awaiting transmission. It is reset when the TxFIFO is loaded by the CPU, or when the transmitter is disabled.

SR[2] – Transmitter Ready (TxRDY)

This bit, when set, indicates that the TxFIFO is ready to be loaded with a character. This bit is cleared when the TxFIFO is loaded by the CPU and is set when the last character is transferred to the transmit shift register. TxRDY is reset when the transmitter is disabled and is set when the transmitter is first enabled, e.g., characters loaded in the TxFIFO while the transmitter is disabled will not be transmitted.

SR[1] – RxFIFO Full (RxFULL)

This bit is set when a character is transferred from the receive shift register to the receive FIFO and the transfer causes the FIFO to become full, i.e., all sixteen RxFIFO positions are occupied. It is reset when the CPU reads the RxFIFO and that read leaves one empty byte position. If a character is waiting in the receive shift register because the RxFIFO is full, RxFULL is not reset until the second read of the RxFIFO since the waiting character is immediately loaded to the RxFIFO.

SR[0] – Receiver Ready (RxRDY)

This bit indicates that a character has been received and is waiting in the RxFIFO to be read by the CPU. It is set when the character is transferred from the receive shift register to the RxFIFO and reset when the CPU reads the RxFIFO, and no more characters are in the RxFIFO.

Table 11. ISR – Interrupt Status Register

Bit 7	Bit 6	Bit 5	Bit 4	Bit 3	Bit 2	Bit 1	Bit 0
I/O Port change of state	Receiver Watch-dog Time-out	Address recognition event	Xon/off event	Always 0	Change of Break State	RxRDY Receiver has entered arbitration process	TxRDY Transmitter has entered arbitration process

This register provides the status of all potential interrupt sources for a UART channel. When generating an interrupt arbitration value, the contents of this register are masked by the interrupt mask register (IMR). If a bit in the ISR is a '1' and the corresponding bit in the IMR is also a '1', interrupt arbitration for this source will begin. If the corresponding bit in the IMR is a zero, the state of the bit in the ISR can have no affect on the IRQN output. Note that the IMR may or may not mask the **reading** of the ISR as determined by MR1[6]. If MR1[6] is cleared, the reset and power on default, the ISR is read without modification. If MR1[6] is set, the a read of the ISR gives a value of the ISR ANDed with the IMR.

ISR[7] – Input Change of State

This bit is set when a change of state occurs at the I/O1 or I/O0 input pins. It is reset when the CPU reads the Input Port Register, IPR.

ISR[6] Watch-dog Time-out

This bit is set when the receiver's watch-dog timer has counted more than 64 bit times since the last RxFIFO event. RxFIFO events are a read of the RxFIFO or GRxFIFO, or the push of a received character into the FIFO. The interrupt will be cleared automatically upon the push of the next character received or when the RxFIFO or GRxFIFO is read. The receiver watch-dog timer is included to allow detection of the very last characters of a received message that may be waiting in the RxFIFO, but are too few in number to successfully initiate an interrupt. Refer to the watch-dog timer description for details of how the interrupt system works after a watch-dog time-out.

ISR[5] – Address Recognition Status Change

This bit is set when a change in receiver state has occurred due to an Address character being received from an external source and

comparing to the reference address in ARCR. The bit and interrupt is negated by a write to the CR with command x11011, Reset Address Recognition Status.

ISR[4] – Xon/Xoff Status Change

This bit is set when an Xon/Xoff character being received from an external source. The bit is negated by a read of the channel Xon Interrupt Status Register, XISR.

ISR[3] – Reserved Always reads a 0

ISR[2] – Change in Channel Break Status

This bit, when set, indicates that the receiver has detected the beginning or the end of a received break. It is reset when the CPU issues a reset break change interrupt command via the CR.

ISR[1] – Receiver Ready

The general function of this bit is to indicate that the RxFIFO has data available. The particular meaning of this bit is programmed by MR2[3:2]. If programmed as receiver ready (MR2[3:2] = 00), it indicates that at least one character has been received and is waiting in the RxFIFO to be read by the host CPU. It is set when the character is transferred from the receive shift register to the RxFIFO and reset when the CPU reads the last character from the RxFIFO.

If MR2[3:2] is programmed as FIFO full, ISR[1] is set when a character is transferred from the receive holding register to the RxFIFO and the transfer causes the RxFIFO to become full, i.e. all sixteen FIFO positions are occupied. It is reset when ever RxFIFO is not full. If there is a character waiting in the receive shift register because the FIFO is full, the bit is set again when the waiting character is transferred into the FIFO.

The other two conditions of these bits, 3/4 and half full operate in a similar manner. The ISR[1] bit is set when the RxFIFO fill level

Octal UART for 3.3 V and 5 V supply voltage

SC28L198

meets or exceeds the value; it is reset when the fill level is less. See the description of the MR2 register.

Note: This bit must be at a one (1) for the receiver to enter the arbitration process. It is the fact that this bit is zero (0) when the RxFIFO is empty that stops an empty FIFO from entering the interrupt arbitration. Also note that the meaning if this bit is not quite the same as the similar bit in the status register (SR).

ISR[0] – Transmitter Ready

The general function of this bit is to indicate that the TxFIFO has an at least one empty space for data. The particular meaning of the bit is controlled by MR0[5:4] indicates the TxFIFO may be loaded with one or more characters. If MR0[5:4] = 00 (the default condition) this bit will not set until the TxFIFO is empty – sixteen bytes available. If

the fill level of the TxFIFO is below the trigger level programmed by the TxINT field of the Mode Register 0, this bit will be set. A one in this position indicates that at least one character can be sent to the TxFIFO. It is turned off as the TxFIFO is filled above the level programmed by MR0[5:4]. This bit turns on as the FIFO empties; the RxFIFO bit turns on as the FIFO fills. This often a point of confusion in programming interrupt functions for the receiver and transmitter FIFOs.

Note: This bit must be at a one (1) for the transmitter to enter the arbitration process. It is the fact that this bit is zero (0) when the RxFIFO is full that stops a full FIFO from entering the interrupt arbitration. Also note that the meaning if this bit is not quite the same as the similar bit in the status register (SR).

Table 12. IMR – Interrupt Mask Register

Bit 7	Bit 6	Bit 5	Bit 4	Bit 3	Bit 2	Bit 1	Bit 0
I/O Port change of state	Receiver Watch-dog Time-out	Address recognition event	Xon/off event	Set to 0	Change of Break State	RxRDY interrupt	TxRDY interrupt

The programming of this register selects which bits in the ISR cause an interrupt output. If a bit in the ISR is a '1' and the corresponding bit in the IMR is a '1', the interrupt source is presented to the internal interrupt arbitration circuits, eventually resulting in the IRQN output being asserted (low). If the corresponding bit in the IMR is a zero, the state of the bit in the ISR has no affect on the IRQN output.

IMR[7] – Controls if a change of state in the inputs equipped with input change detectors will cause an interrupt.

IMR[6] – Controls the generation of an interrupt by the watch-dog timer event. If set, a count of 64 idle bit times in the receiver will begin interrupt arbitration.

Table 13. RxFIFO Receiver FIFO

Bit[10]	Bit[9]	Bit[8]	Bits [7:0]
Break Received Status	Framing Error Status	Parity Error Status	8 data bits MSBs =0 for 7,6,5 bit data

The FIFO for the receiver is 11 bits wide and 16 "words" deep. The status of each byte received is stored with that byte and is moved along with the byte as the characters are read from the FIFO. The upper three bits are presented in the STATUS register and they change in the status register each time a data byte is read from the FIFO. Therefore the status register should be read BEFORE the byte is read from the RxFIFO if one wishes to ascertain the quality of the byte

The forgoing applies to the "character error" mode of status reporting. See MR1[5] and "RxFIFO Status" descriptions for "block error" status reporting. Briefly "Block Error" gives the accumulated error of all bytes received in the RxFIFO since the last "Reset Error" command was issued. (CR = x'04)

Table 14. TxFIFO – Transmitter FIFO

Bits 7:0
8 data bits. MSBs set to 0 for 7, 6, 5 bit data

The FIFO for the transmitter is 8 bits wide by 16 bytes deep. For character lengths less than 8 bits the upper bits will be ignored by the transmitter state machine and thus are effectively discarded.

IMR[5] – Enables the generation of an interrupt in response to changes in the Address Recognition circuitry of the Special Mode (multi-drop or wake-up mode).

IMR[4] – Enables the generation of an interrupt in response to recognition of an in-band flow control character.

IMR[3] – Reserved

IMR[2] – Enables the generation of an interrupt when a Break condition has been detected by the channel receiver.

IMR[1] – Enables the generation of an interrupt when servicing for the RxFIFO is desired.

IMR[0] – Enables the generation of an interrupt when servicing for the TxFIFO is desired.

Table 15. BCRBRK – Bidding Control Register – Break Change

Bits 7:3	Bits 2:0
Reserved	MSB of break change interrupt bid

This register provides the 3 MSBs of the Interrupt Arbitration number for a break change interrupt.

Table 16. BCR COS – Bidding Control Register – Change of State

Bits 7:3	Bits 2:0
Reserved	MSB of a COS interrupt bid
Read as x'0	

This register provides the 3 MSBs of the Interrupt Arbitration number for a Change of State, COS, interrupt.

Table 17. BCRx – Bidding Control Register – Xon

Bits 7:3	Bits 2:0
Reserved	MSB of an Xon/Xoff interrupt bid

This register provides the 3 MSBs of the Interrupt Arbitration number for an Xon/Xoff interrupt.

Octal UART for 3.3 V and 5 V supply voltage

SC28L198

Table 18. BCRA – Bidding Control Register – Address

Bits 7:3	Bits 2:0
Reserved	MSB of an address recognition event interrupt bid

This register provides the 3 MSBs of the Interrupt Arbitration number for an address recognition event interrupt.

Table 19. XonCR – Xon Character Register

Bits 7:0
8 Bits of the Xon Character Recognition

An 8 bit character register that contains the compare value for an Xon character.

Table 20. XoffCR – Xoff Character Register

Bits 7:0
8 Bits of the Xoff Character Recognition

An 8 bit character register that contains the compare value for an Xoff character.

Table 21. ARCR – Address Recognition Character Register

Bits 7:0
8 Bits of the Multi-Drop Address Character Recognition

An 8 bit character register that contains the compare value for the wake-up address character

Octal UART for 3.3 V and 5 V supply voltage

SC28L198

Table 22. XISR – Xon–Xoff Interrupt Status Register

Bits 7:6	Bits 5:4	Bits 3:2	Bits 1:0
Received X Character Status	Automatic X Character transmission status	TxD flow status	TxD character status
00 – none 01 – Xoff received 10 – Xon received 11 – both received	00 – none 01 – Xon transmitted 10 – Xoff transmitted 11 – Illegal, does not occur	00 – normal 01 – TxD halt pending 10 – re-enabled 11 – flow disabled	00 – normal TxD data 01 – wait on normal data 10 – Xoff in pending 11 – Xon in pending

XISR[7:6] – Received X Character Status. This field can be read to determine if the receiver has encountered an Xon or Xoff character in the incoming data stream. These bits are maintained until a read of the XISR. The field is updated by X character reception regardless of the state of MR0(7, 3:2) or IMR(4). The field can therefore be used as a character detector for the bit patterns stored in the Xon and Xoff Character Registers.

XISR[5:4] – Automatic transmission Status. This field indicates the last flow control character sent in the Auto Receiver flow control mode. If Auto Receiver mode has not been enabled, this field will always read b'00. It will likewise reset to b'00 if MR0(3) is reset. If the Auto Receiver mode is exited while this field reads b'10, it is the user's responsibility to transmit an Xon, when appropriate.

XISR[3:2] – TxD flow Status. This field tracks the transmitter's flow status as follows:

- 00 – normal. The flow control is under host control.
- 01 – TxD halt pending. After the current character finishes the transmitter will stop. The status will then change to b'00.
- 10 – re-enabled. The transmitter had been halted and restarted. It is sending data characters. After a read of the XISR, it will return to "normal" status.
- 11 – disabled. The transmitter is flow controlled.

XISR[1:0] – TxD character Status. This field allows determination of the type of character being transmitted. If XISR(1:0) is b'01, the channel is waiting for a data character to transfer from the TxFIFO. This condition will only occur for a bit time after an Xon or Xoff character transmission unless the TxFIFO is empty.

Table 26. BRGTCR – BRG Timer Control Register (BRGTCR)

Bit 7	Bit 6:4	Bit 3	Bit 2:0
BRGTCR b, Register control	BRGTCR b, Clock selection	BRGTCR a, Register control	BRGTCR a, Clock selection
0 – Resets the timer register and holds it stopped 1 – Allows the timer register to run.	000 – Sclk / 16 001 – Sclk / 32 010 – Sclk / 64 011 – Sclk / 128 100 – X1 101 – X1 / 2 110 – I/O1b 111 – G _{IN} (1)	0 – Resets the timer register and holds it stopped. 1 – Allows the timer register to run.	000 – Sclk / 16 001 – Sclk / 32 010 – Sclk / 64 011 – Sclk / 128 100 – X1 101 – X1 / 2 110 – I/O1a 111 – G _{IN} (0)

Start/Stop control and clock select register for the two BRG counters. The clock selection is for the input to the counters. It is that clock divided by the number represented by the BRGTU and BRGTL the will be used as the 16x clock for the receivers and transmitters. When the BRG timer Clock is selected for the

Table 23. WDTRCR – Watch-dog Timer Enable Register

Bit 7	Bit 6	Bit 5	Bit 4	Bit 3	Bit 2	Bit 1	Bit 0
WDT h	WDT g	WDT f	WDT e	WDT d	WDT c	WDT b	WDT a
1 on 0 off	1 on 0 off	1 on 0 off	1 on 0 off	1 on 0 off	1 on 0 off	1 on 0 off	1 on 0 off

This register enables the watch-dog Timer for each of the 8 receivers on the Octal UART.

Table 24. BRGTRU – BRG Timer Reload Registers, Upper

Bits 7:0
8 MSB of the BRG Timer divisor.

This is the upper byte of the 16 bit value used by the BRG timer in generating a baud rate clock

Table 25. BRGTRL – BRG Timer Reload Registers, Lower

Bits 7:0
8 LSB of the BRG Timer divisor.

This is the lower byte of the 16 bit value used by the BRG timer in generating a baud rate clock.

receiver(s) or transmitter(s) the receivers and transmitters will consider it as a 16x clock and further device it by 16. In other words the receivers and transmitters will always be in the 16x ode of operation when the internal BRG timer is selected for their clock.

Octal UART for 3.3 V and 5 V supply voltage

SC28L198

Table 27. ICR – Interrupt Control Register

Bit 7	Bits 6:0
Reserved. Set to 0	Upper seven bits of the Arbitration Threshold

This register provides a single 7 bit field called the interrupt threshold for use by the interrupt arbiter. The field is interpreted as a single unsigned integer. The interrupt arbiter will not generate an external interrupt request, by asserting IRQN, unless the value of the highest priority interrupt exceeds the value of the interrupt threshold. If the highest bidder in the interrupt arbitration is lower than the threshold level set by the ICR, the Current Interrupt Register, CIR, will contain x'00. Refer to the functional description of interrupt generation for details on how the various interrupt source bid values are calculated.

Note: While a watch-dog Timer interrupt is pending, the ICR is not used and only receiver codes are presented for interrupt arbitration. This allows receivers with very low count values (perhaps below the threshold value) to win interrupt arbitration without requiring the user to explicitly lower the threshold level in the ICR. These bits are the upper seven (7) bits of the interrupt arbitration system. The lower three (3) bits represent the channel number.

UCIR – Update CIR

A command based upon a decode of address x'8C. (UCIR is not a register!) A write (the write data is not important; a “don't care”) to this 'register' causes the Current Interrupt Register to be updated with the value that is winning interrupt arbitration. The register would be used in systems that poll the interrupt status registers rather than wait for interrupts. Alternatively, the CIR is normally updated during an Interrupt Acknowledge Bus cycle in interrupt driven systems.

Table 28. CIR – Current Interrupt Register

Bits 7:6	Bits 5:3	Bits 2:0
Type	Current byte count/type	Channel number
00 – other	000 – no interrupt	000 = a
	001 – Change of State	001 = b
	010 – Address Recognition	010 = c
	011 – Xon/Xoff status	011 = d
	100 – Not used	.
	101 – Break change	.
	110, 111 do not occur	111 = h
01 – Transmit 11 – Receive w/ errors 10 – Receive w/o errors	Current count code	000 = a
	0 => 9 or less characters	001 = b
	1 => 10 characters	010 = c
	.	011 = d
	.	.
	5 => 14 characters	.
	6 => 15 characters 7 => 16 (See also GIBCR)	111 = h

The Current Interrupt Register is provided to speed up the specification of the interrupting condition in the Octal UART. The CIR is updated at the beginning of an interrupt acknowledge bus cycle or in response to an Update CIR command. (see immediately above) Although interrupt arbitration continues in the background,

the current interrupt information remains frozen in the CIR until another IACKN cycle or Update CIR command occurs. The LSBs of the CIR provide part of the addressing for various Global Interrupt registers including the GIBCR, GICR, GITR and the Global Rx FIFO and Tx FIFO FIFO. The host CPU need not generate individual addresses for this information since the interrupt context will remain stable at the fixed addresses of the Global Interrupt registers until the CIR is updated. For most interrupting sources, the data available in the CIR alone will be sufficient to set up a service routine.

The CIR may be processed as follows:

If CIR[7] = 1, then a receiver interrupt is pending and the count is CIR[5:3], channel is CIR[2:0]

Else If CIR[6] = 1 then a transmitter interrupt is pending and the count is CIR[5:3], channel is CIR[2:0]

Else the interrupt is another type, specified in CIR[5:3]

Note: The GIBCR, Global Interrupting Byte Count Register, may be read to determine an exact character count if 9 or less characters are indicated in the count field of the CIR.

Table 29. IVR – Interrupt Vector Register

Bits 7:0
8 data bits of the Interrupt Vector (IVR)

The IVR contains the byte that will be placed on the data bus during an IACKN cycle when the GCCR bits (2:1) are set to binary '01'. This is the unmodified form of the interrupt vector.

Table 30. Modification of the IVR

Bits 7:5	Bits 4:3	Bits 2:0
Always contains bits (7:5) of the IVR	Will be replaced with current interrupt type if IVC field of GCCR > 1	Replaced with interrupting channel number if IVC field of GCCR > 0

The table above indicates how the IVR may be modified by the interrupting source. The modification of the IVR as it is presented to the data bus during an IACK cycle is controlled by the setting of the bits (2:1) in the GCCR (Global Chip Configuration Register)

Table 31. GICR – Global Interrupting Channel Register

Bits 7:3	Bits 2:0
Reserved	Channel code
	100 = e 000 = a
	101 = f 001 = b
	110 = g 010 = c
	111 = h 011 = d

A register associated with the interrupting channel as defined in the CIR. It contains the interrupting channel code for all interrupts.

Octal UART for 3.3 V and 5 V supply voltage

SC28L198

Table 32. GIBCR – Global Interrupting Byte Count Register

Bits 7:4	Bits 3:0
Reserved	Channel byte count code
	0000 = 1 AND RxRDY status set for RxFIFO
	0000 = 1 AND TxRDY status set for TxD
	0001 = 2
	0010 = 3
	.
	1111 = 16

A register associated with the interrupting channel as defined in the CIR. Its numerical value equals

the number of bytes minus 1 (count – 1) ready for transfer to the transmitter or transfer from the receiver. It is undefined for other types of interrupts

Table 33. Global Interrupting Type Register

Bit 7:6	Bit 5	Bit 4:3	Bit 2:0
Receiver Interrupt	Transmitter Interrupt	Reserved	Other types
0x – not receiver 10 – with receive errors 11 – w/o receive errors	0 – not transmitter 1 – transmitter interrupt	read b'00	000 – not "other" type 001 – Change of State 010 – Address Recognition Event 011 – Xon/Xoff status 100 – Not used 101 – Break Change 11x – do not occur

A register associated with the interrupting channel as defined in the CIR. It contains the type of interrupt code for all interrupts.

Table 34. GRxFIFO – Global Rx FIFO Register

Bits 7:0
8 data bits of Rx FIFO. MSBs set to 0 for 7, 6, 5 bit data

The Rx FIFO of the channel indicated in the CIR channel field. Undefined when the CIR interrupt context is not a receiver interrupt. Global Tx FIFO Register

Table 35. GTxFIFO – Global Tx FIFO Register

Bits 7:0
8 data bits of Tx FIFO. MSBs not used for 7, 6, 5 bit data

The Tx FIFO of the channel indicated in the CIR channel field. Undefined when the CIR interrupt context is not a transmitter event may result in the characters being transmitted on a different channel than intended.

Table 36. IPR – Input Port Register,

Bit 7	Bit 6	Bit 7	Bit 6	Bit 3	Bit 2	Bit 1	Bit 0
I/O3 change	I/O2 change	I/O1 change	I/O0 change	I/O3 state	I/O2 state	I/O1 state	I/O0 state
0 – no change 1 – change	0 – no change 1 – change	0 – no change 1 – change	0 – no change 1 – change	The actual logic level at the I/O pin. 1 = high level; 0 = low level.			

This register may be read to determine the current level of the I/O pins and examine the output of the change detectors assigned to

each pin. If the change detection is not enabled or if the pin is configured as an output, the associated change field will read b'0.

Table 37. I/OPIOR – I/O Port Interrupt and Output Register

Bit 7	Bit 6	Bit 5	Bit 4	Bit 3	Bit 2	Bit 1	Bit 0
I/O3 enable	I/O2 enable	I/O1 enable	I/O0 enable	I/O3 output	I/O2 output	I/O1 output	I/O0 output
0 – disable 1 – enable	0 – disable 1 – enable	0 – disable 1 – enable	0 – disable 1 – enable	OPR[3]	OPR[2]	OPR[1]	OPR[0]

I/OPIOR[7:4] bits activate the input change of state detectors. If a pin is configured as an output, a b'1 value written to a I/O field has no effect.

I/OPIOR[3:0] bits hold the datum which is the inverse of the datum driven to its associated I/O pin when the I/OPCR control bits for that pin are programmed to b'01.

Octal UART for 3.3 V and 5 V supply voltage

SC28L198

Table 38. I/OPCR – I/O Port Configuration Register

Bits 7:6	Bits 5:4	Bits 3:2	Bits 1:0
I/O3 control	I/O2 control	I/O1 control	I/O0 control
00 – GPI/TxC input 01 – I/OPIOR[3] output 10 – TxC16x output 11 – TxC1x output	00 – GPI/RxC input 01 – I/OPIOR[2]/RTSN * 10 – RxC1x output 11 – RxC16x output	00 – GPI input 01 – I/OPIOR[1]/RTSN * 10 – Reserved 11 – RxC1x output	00 – GPI/CTSN input 01 – I/OPIOR[0]output 10 – TxC1x output 11 – TxC16x output

* If I/OPCR(5:4) is programmed as '01' then the RTSN functionality is assigned to I/O2, otherwise, this function can be implemented on I/O1. (This allows for a lower pin count package option)

This register contains 4, 2 bit fields that set the direction and source for each of the I/O pins associated with the channel. The I/O2 output may be RTSN if MR1[7] is set, or may signal "end of transmission" if MR2[5] is set. (Please see the descriptions of these functions under the MR1 and MR2 register descriptions) If this control bit is cleared, the pin will use the OPR[2] as a source if I/OPCR[5:4] is b'01. The b'00 combinations are always inputs. This register resets to x'0, effectively configuring all I/O pins as inputs on power up or reset. Inputs may be used as RxC, TxC inputs or CTSN and General Purpose Inputs simultaneously. All inputs are equipped with change detectors that may be used to generate interrupts or can be polled, as required.

NOTE: To ensure that CTSN, RTSN and an external RxC are always available, if I/O2 is not selected as the RTSN output, the RTSN function is automatically provided on I/O1.

GENERAL PURPOSE OUTPUT PIN CONTROL

The following four registers control the function of the G_{OUT}0 pin. These output pins have a unique control matrix which includes a clocking mechanism that will allow the pin to change synchronously with an internal or external stimulus. See diagram below.

Table 39. GPOSR – General Purpose Output Select Register

GPOSR selects the signal or data source for the G_{OUT}0 pin. The Tx and Rx clock selection is straight forward. The selection of the GPOR allows a more flexible timing control of when the G_{OUT}0 pin changes.

Bits 7:4	Bits 3:0
Reserved	Global General Purpose Output 0 Selection
	0000 – 0111 reserved 1000 = TxC1x a 1001 = TxC16x a 1010 = RxC16x a 1011 = TxC16x b 1100 = GGPOR(3) 1101 = GGPOR(2) 1110 = GGPOR(1) 1111 = GGPOR(0)

Table 40. GPOR – General Purpose Output Register

This register is a read/write register. Its contents may be altered by a GPOR Write or by the GPOC and GPOD registers shown below. The GPOD and GPOC may be programmed to cause the individual bits of the GPOR to change synchronously with internal or external events. The cells of this register may be thought of as a "Two Port flip-flop"; one port is controlled by a D input and clock, the other by a data load strobe. A read of the GPOR always returns its current value regardless of the port from which it was loaded.

Bits 7:4	Bit 3	Bit 2	Bit 1	Bit 0
Reserved	GPOR(3)	GPOR(2)	GPOR(1)	GPOR(0)

Table 41. GPOC – General Purpose Output Clk Register

This controls the clock source for GPOR that will clock and/or toggle the data from the selected GPOD source. When code b'00 is selected, no clock will be provided, thereby preventing any change through the D port.

Bits 7:6	Bits 5:4	Bits 3:2	Bits 1:0
Clk Sel GPOR(3)	Clk Sel GPOR(2)	Clk Sel GPOR(1)	Clk Sel GPOR(0)
00 = none 01 = G _{IN} 0 10 = G _{IN} 1 11 = reserved	00 = none 01 = G _{IN} 0 10 = G _{IN} 1 11 = reserved	00 = none 01 = G _{IN} 0 10 = G _{IN} 1 11 = I/O3c	00 = none 01 = G _{IN} 0 10 = G _{IN} 1 11 = I/O3a

Table 42. GPOD – General Purpose Output Data Register

This register selects the data that will be presented to the GPOR "D" input. Note that selection b'10 selects the inverted GPOR data as the input. In this case, the GPOR output will toggle synchronously with the clock selected in the GPOC.

Bits 7:6	Bits 5:4	Bits 3:2	Bits 1:0
Data Sel GPOR(3)	Data Sel GPOR(2)	Data Sel GPOR(1)	Data Sel GPOR(0)
00 = '1' 01 = '0' 10 = GPOR3N 11 = reserved	00 = '1' 01 = '0' 10 = GPOR2N 11 = reserved	00 = '1' 01 = '0' 10 = GPOR1N 11 = I/O3d	00 = '1' 01 = '0' 10 = GPOR0N 11 = I/O3b

Octal UART for 3.3 V and 5 V supply voltage

SC28L198

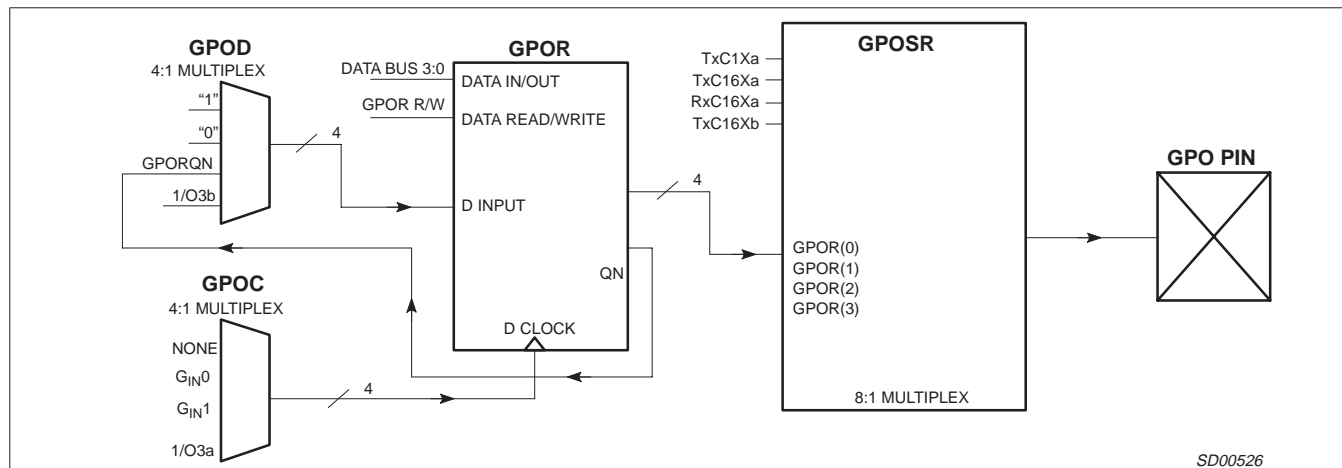

Figure 1. General Purpose Pin Control Logic

SD00526

REGISTER MAPS

The registers of the SC28L198 are partitioned into two groups: those used in controlling data channels and those used in handling the actual data flow and status. Below is shown the general configuration of all the register addressed. The "Register Map Summary" shows the configuration of the lower four bits of the address that is the same for the individual UARTs. It also shows the addresses for the several in the address space of UART A and

UART B that apply to the total chip configuration. The "Register Map Detail" shows the use of every address in the 8 bit address space.

NOTE: The register maps for channels A and B (UARTs A and B) contain some control registers that configure the entire chip. **These are denoted by a ♣ symbol.**

REGISTER MAP SUMMARY

Table 43. Summary Register Map, Control

Address (hex) ccc = channel	Register Name	Acronym	Read / Write
0ccc 0000 (x00)	Mode Register 0 MR0a	MR0	R/W
0ccc 0001 (x01)	Mode Register 1 MR1a	MR1	R/W
0ccc 0010 (x02)	I/O Port Configuration Reg a I/OPCRa	IOPCR	R/W
0ccc 0011 (x03)	Bid Control, Break Change	BCRBRK	R/W
0ccc 0100 (x04)	Bid Control, Change of State	BCRCOS	R/W
0ccc 0110 (x06)	Bid Control, Xon/Xoff	BCRX	R/W
0ccc 0111 (x07)	Bid Control, Address recognition	BCRA	R/W
0ccc 1000 (x08)	Xon Character Register	XonCR	R/W
0ccc 1001 (x09)	Xoff Character Register	XoffCR	R/W
0ccc 1010 (x0A)	Address Recognition Character	ARCR	R/W
0ccc 1100 (x0C)	Receiver Clock Select Register	RxCSR	R/W
0000 1101 (x0D)	♣ Test Register	Reserved, set to 0	
0ccc 1110 (x0E)	Transmitter Clock Select Register	TxCSR	R/W
0000 1111 (x0F)	♣ Global Chip Configuration Register	GCCR	R/W
0001 1011 (x1B)	♣ Interrupt Control Register	ICR	R/W
0001 1101 (x1D)	♣ Watch-dog Timer Run Control	WDTRCR	R/W
0001 1111 (x1F)	♣ Interrupt Vector Register	IVR	R/W

Octal UART for 3.3 V and 5 V supply voltage

SC28L198

Table 44. Summary Register Map, Data

Address (hex) ccc = Channel	Register Name	Acronym	Read/Write
1ccc 0000 (x80)	Mode Register 2	MR2	R/W
1ccc 0001 (x81)	Status Register	SR	R
1ccc 0001 (x81)	Command Register	CR	W
1ccc 0010 (x82)	Interrupt Status Register	ISR	R
1ccc 0010 (x82)	Interrupt Mask Register	IMR	W
1ccc 0011 (x83)	Transmitter FIFO Register	TxFIFO	W
1ccc 0011 (x83)	Receiver FIFO Reg	RxFIFO	R
1ccc 0100 (x84)	Input Port Reg	IPR	R
1000 0100 (x84)	♣ BRG Timer Reg Upper a	BRGTRUa	W
1ccc 0101 (x85)	I/O Port Interrupt and Output	I/OPIOR	R/W
1ccc 0110 (x86)	Xon/Xoff Interrupt Status Reg	XISR	R
1000 0111 (x87)	♣ GP Out Select Reg	GPOSR	R/W
1000 1011 (x8B)	♣ GP Out Clk Reg	GPOC	R/W
1000 1100 (x8C)	♣ Update Current Interrupt Reg	UCIR	W
1000 1100 (x8C)	♣ Current Interrupt Reg	CIR	R
1001 1101 (x9D)	♣ BRG Timer Reg Upper b	BRGTRUb	W
1000 1110 (x8E)	♣ Global Receive FIFO Reg	GRxFIFO	R
1000 1110 (x8E)	♣ Global Transmit FIFO Reg	GTxFIFO	W
1000 1111 (x8F)	♣ Global Chip Configuration Reg	GCCR	R/W
1001 0100 (x94)	♣ BRG Timer Reg Lower a	BGRTRLa	W
1001 0111 (x97)	♣ GP Output Reg	GPOR	R/W
1001 1011 (x9B)	♣ GP Out Data Reg	GPOD	R/W
1001 1100 (x9C)	♣ BRG Timer Control Reg	BRGTCCR	W
1001 1100 (x9C)	♣ Global Interrupt Channel Reg	GICR	R
1001 1101 (x9D)	♣ BRG Timer Reg Lower b	BRGTRLb	W
1001 1101 (x9D)	♣ Global Interrupt Byte Count	GIBCR	R
1001 1111 (x9F)	♣ Global Interrupt Type Register	GITR	R

REGISTER MAP DETAIL

Table 45. Register Map, Control

NOTE: The register maps for channels A and B (UARTs A and B) contain some control registers that configure the entire chip. **These are denoted by a ♣ symbol**

A(7:0)	UART A	
	Read	Write
0000 0000 (x00)	Mode Register 0 MR0a	Mode Register 0 MR0a
0000 0001 (x01)	Mode Register 1 MR1a	Mode Register 1 MR1a
0000 0010 (x02)	I/O Port Configuration Reg a I/OPCRa	I/O Port Configuration Reg a I/OPCRa
0000 0011 (x03)	BCRBRKa	BCRBRKa
0000 0100 (x04)	BCRCOSa	BCRCOSa
0000 0101 (x05)	Reserved	Reserved
0000 0110 (x06)	BCRXa	BCRXa
0000 0111 (x07)	BCRAa	BCRAa
0000 1000 (x08)	Xon Character Reg a (XonCRa)	Xon Character Reg a (XonCRa)
0000 1001 (x09)	Xoff Character Reg a (XoffCRa)	Xoff Character Reg a (XoffCRa)
0000 1010 (x0A)	Address Recognition Character a (ARCRa)	Address Recognition Character a (ARCRa)
0000 1011 (x0B)	Reserved	Reserved
0000 1100 (x0C)	Receiver Clock Select Register a (RxCSRa)	Receiver Clock Select Register a (RxCSRa)
0000 1101 (x0D)	♣ Test Register	Test Register
0000 1110 (x0E)	Xmit Clock Select Register a TxCSRa)	Xmit Clock Select Register a TxCSRa)
0000 1111 (x0F)	♣ Global Chip Configuration Reg(GCCR)	Global Chip Configuration Reg GCCR)

Octal UART for 3.3 V and 5 V supply voltage

SC28L198

A(7:0)	UART B	
	Read	Write
0001 0000 (x10)	Mode Register 0 MR0b	Mode Register 0 MR0b
0001 0001 (x11)	Mode Register 1 MR1b	Mode Register 1 MR1b
0001 0010 (x12)	I/O Port Configuration Reg b I/OPCRb	I/O Port Configuration Reg b I/OPCRb
0001 0011 (x13)	BCRBRKb	BCRBRKb
0001 0100 (x14)	BCRCOSb	BCRCOSb
0001 0101 (x15)	Reserved	Reserved
0001 0110 (x16)	BCRXb	BCRXb
0001 0111 (x17)	BCRAb	BCRAb
0001 1000 (x18)	Xon Character Reg b (XonCRb)	Xon Character Reg b (XonCRb)
0001 1001 (x19)	Xoff Character Reg b (XoffCRb)	Xoff Character Reg b (XoffCRb)
0001 1010 (x1A)	Address Recognition Character b (ARCRb)	Address Recognition Character b (ARCRb)
0001 1011 (x1B)	♣ Interrupt Control Register (ICR)	Interrupt Control Register (ICR)
0001 1100 (x1C)	Receiver Clock Select Register b (RxCSRb)	Receiver Clock Select Register b (RxCSRb)
0001 1101 (x1D)	♣ Watch-dog Timer Run Control (WDTRCR)	Watch-dog Timer Run Control (WDTRCR)
0001 1110 (x1E)	Xmit Clock Select Register b (TxCSRb)	Xmit Clock Select Register b (TxCSRb)
0001 1111 (x1F)	♣ Interrupt Vector Register (IVR)	Interrupt Vector Register (IVR)
A(7:0)	UART C	
	Read	Write
0010 0000 (x20)	Mode Register 0 MR0c	Mode Register 0 MR0c
0010 0001 (x21)	Mode Register 1	Mode Register 1 MR1c
0010 0010 (x22)	I/O Port Configuration Reg c I/OPCRc	I/O Port Configuration Reg c I/OPCRc
0010 0011 (x23)	BCRBRKc	BCRBRKc
0010 0100 (x24)	BCRCOSc	BCRCOSc
0010 0101 (x25)	Reserved	Reserved
0010 0110 (x26)	BCRXc	BCRXc
0010 0111 (x27)	BCRAc	BCRAc
0010 1000 (x28)	Xon Character Reg c (XonCRc)	Xon Character Reg c (XonCRc)
0010 1001 (x29)	Xoff Character Reg c (XoffCRc)	Xoff Character Reg c (XoffCRc)
0010 1010 (x2A)	Address Recognition Character c (ARCRc)	Address Recognition Character c (ARCRc)
0010 1011 (x2B)	Reserved	Reserved
0010 1100 (x2C)	Receiver Clock Select Register c (RxCSRc)	Receiver Clock Select Register c (RxCSRc)
0010 1101 (x2D)	Reserved	Reserved
0010 1110 (x2E)	Xmit Clock Select Register c (TxCSRc)	Xmit Clock Select Register c (TxCSRc)
0010 1111 (x2F)	Reserved	Reserved

Octal UART for 3.3 V and 5 V supply voltage

SC28L198

A(7:0)	UART D	
	Read	Write
0011 0000 (x30)	Mode Register 0 MR0d	Mode Register 0 MR0d
0011 0001 (x31)	Mode Register 1 MR1d	Mode Register 1 MR1d
0011 0010 (x32)	I/O Port Configuration Reg d I/OPCRd	I/O Port Configuration Reg d I/OPCRd
0011 0011 (x33)	BCRBRKd	BCRBRKd
0011 0100 (x34)	BCRCOSd	BCRCOSd
0011 0101 (x35)	Reserved	Reserved
0011 0110 (x36)	BCRXd	BCRXd
0011 0111 (x37)	BCRA d	BCRA d
0011 1000 (x38)	Xon Character Reg d (XonCRd)	Xon Character Reg d (XonCRd)
0011 1001 (x39)	Xoff Character Reg d (XoffCRd)	Xoff Character Reg d (XoffCRd)
0011 1010 (x3A)	Address Recognition Character d (ARCRd)	Address Recognition Character d (ARCRd)
0011 1011 (x3B)	Reserved	Reserved
0011 1100 (x3C)	Receiver Clock Select Register d (RxCSRd)	Receiver Clock Select Register d (RxCSRd)
0011 1101 (x3D)	Reserved	Reserved
0011 1110 (x3E)	Xmit Clock Select Register d (TxCSRd)	Xmit Clock Select Register d (TxCSRd)
0011 1111 (x3F)	Reserved	Reserved
A(7:0)	Read	Write
	UART E	
01000000 (x40)	Mode Register 0 MR0e	Mode Register 0 MR0e
01000001 (x41)	Mode Register 1 MR1e	Mode Register 1 MR1e
01000010 (x42)	I/O Port Configuration Reg e I/OPCRE	I/O Port Configuration Reg e I/OPCRE
01000011 (x43)	BCRBRKe	BCRBRKe
01000100 (x44)	BCRCOSe	BCRCOSe
01000101 (x45)	Reserved	Reserved
01000110 (x46)	BCRXe	BCRXe
01000111 (x47)	BCRAe	BCRAe
01001000 (x48)	Xon Character Reg e (XonCRE)	Xon Character Reg e (XonCRE)
01001001 (x49)	Xoff Character Reg e (XoffCRE)	Xoff Character Reg e (XoffCRE)
01001010 (x4A)	Address Recognition Char e (ARCRE)	Address Recognition Char e (ARCRE)
01001011 (x4B)	Reserved	Reserved
01001100 (x4C)	Receiver Clock Select Register e (RxCSRe)	Receiver Clock Select Register e (RxCSRe)
01001101 (x4D)	Reserved	Reserved
01001110 (x4E)	Xmit Clock Select Register e (TxCSRe)	Xmit Clock Select Register e (TxCSRe)
01001111 (x4F)	Reserved	Reserved

Octal UART for 3.3 V and 5 V supply voltage

SC28L198

UART F		
01010000 (x50)	Mode Register 0 MR0f	Mode Register 0 MR0f
01010001 (x51)	Mode Register 1 MR1f	Mode Register 1 MR1f
01010010 (x52)	I/OPort Configuration Reg f I/OPCRf	I/OPort Configuration Reg f I/OPCRf
01010011 (x53)	BCRBRKf	BCRBRKf
01010100 (x54)	BCRCOSf	BCRCOSf
01010101 (x55)	Reserved	Reserved
01010110 (x56)	BCRXf	BCRXf
01010111 (x57)	BCRAf	BCRAf
01011000 (x58)	Xon Character Reg f (XonCRf)	Xon Character Reg f (XonCRf)
01011001 (x59)	Xoff Character Reg f (XoffCRf)	Xoff Character Reg f (XoffCRf)
01011010 (x5A)	Address Recognition Char f (ARCRf)	Address Recognition Char f (ARCRf)
01011011 (x5B)	Reserved	Reserved
01011100 (x5C)	Receiver Clock Select Register f (RxCSRf)	Receiver Clock Select Register f (RxCSRf)
01011101 (x5D)	Reserved	Reserved
01011110 (x5E)	Xmit Clock Select Register f (TxCSRf)	Xmit Clock Select Register f (TxCSRf)
01011111 (x5F)	Reserved	Reserved
A(7:0)	Read	Write
UART G		
01100000 (x60)	Mode Register 0 MR0g	Mode Register 0 MR0g
01100001 (x61)	Mode Register 1 MR1g	Mode Register 1 MR1g
01100010 (x62)	I/OPort Configuration Reg g I/OPCRg	I/OPort Configuration Reg g I/OPCRg
01100011 (x63)	BCRBRKg	BCRBRKg
01100100 (x64)	BCRCOSg	BCRCOSg
01100101 (x65)	Reserved	Reserved
01100110 (x66)	BCRXg	BCRXg
01100111 (x67)	BCRAg	BCRAg
01101000 (x68)	Xon Character Reg g (XonCRg)	Xon Character Reg g (XonCRg)
01101001 (x69)	Xoff Character Reg g (XoffCRg)	Xoff Character Reg g (XoffCRg)
01101010 (x6A)	Address Recognition Char g (ARCRg)	Address Recognition Char g (ARCRg)
01101011 (x6B)	Reserved	Reserved
01101100 (x6C)	Receiver Clock Select Register g (RxCSRg)	Receiver Clock Select Register g (RxCSRg)
01101101 (x6D)	Reserved	Reserved
01101110 (x6E)	Xmit Clock Select Register g (TxCSRg)	Xmit Clock Select Register g (TxCSRg)
01101111 (x6F)	Reserved	Reserved

Octal UART for 3.3 V and 5 V supply voltage

SC28L198

	UART H	
01110000 (x70)	Mode Register 0 MR0h	Mode Register 0 MR0h
01110001 (x71)	Mode Register 1 MR1h	Mode Register 1 MR1h
01110010 (x72)	I/OPort Configuration Reg h I/OPCRh	I/OPort Configuration Reg h I/OPCRh
01110011 (x73)	BCRBRKh	BCRBRKh
01110100 (x74)	BCRCOSh	BCRCOSh
01110101 (x75)	Reserved	Reserved
01110110 (x76)	BCRXh	BCRXh
01110111 (x77)	BCRAh	BCRAh
01111000 (x78)	Xon Character Reg h (XonCRh)	Xon Character Reg h (XonCRh)
01111001 (x79)	Xoff Character Reg h (XoffCRh)	Xoff Character Reg h (XoffCRh)
01111010 (x7A)	Address Recognition Char h (ARCRh)	Address Recognition Char h (ARCRh)
01111011 (x7B)	Reserved	Reserved
01111100 (x7C)	Receiver Clock Select Register h (RxCSRh)	Receiver Clock Select Register h (RxCSRh)
01111101 (x7D)	Reserved	Reserved
01111110 (x7E)	Xmit Clock Select Register h (TxCSRh)	Xmit Clock Select Register h (TxCSRh)
01111111 (x7F)	Reserved	Reserved

Octal UART for 3.3 V and 5 V supply voltage

SC28L198

Table 46. Register Map, Data

A(7:0)	UART A	
	Read	Write
1000 0000 (x80)	Mode Register a (MR2a)	Mode Register a (MR2a)
1000 0001 (x81)	Status Register a (SRa)	Command Register a (CRa)
1000 0010 (x82)	Interrupt Status Register a (ISRa)	Interrupt Mask Register a (IMRa)
1000 0011 (x83)	Receiver FIFO Reg a (RxFIFOa)	Transmitter FIFO Reg a (TxFIFOa)
1000 0100 (x84)	Reserved	✦ BRG Timer Reg Upper a (BRGTRUa)
1000 0100 (x84)	Input Port Reg a (IPRa)	Reserved
1000 0101 (x85)	I/O Port Interrupt and Output a (I/OPIORa)	I/O Port Interrupt and Output a (I/OPIORa)
1000 0110 (x86)	Xon/Xoff Interrupt Status Reg a (XISRa)	Reserved
1000 0111 (x87)	✦ GP Out Select Reg (GPOSR)	GP Out Select Reg (GPOSR)
1000 1011 (x8B)	✦ GP Out Clk Reg (GPOC)	GP Out Clk Reg (GPOC)
1000 1100 (x8C)	✦ Current Interrupt Reg (CIR)	✦ Update CIR
1000 1101 (x8D)	Reserved	✦ BRG Timer Reg Upper b (BRGTRUb)
1000 1110 (x8E)	✦ Global Receive FIFO Reg (GRxFIFO)	✦ Global Transmit FIFO Reg (GTxFIFO)
1000 1111 (x8F)	✦ Global Chip Configuration Reg (GCCR)	✦ Global Chip Configuration Reg (GCCR)
A(7:0)	UART B	
	Read	Write
1001 0000 (x90)	Mode Register b (MR2b)	Mode Register b (MR2b)
1001 0001 (x91)	Status Register b (SRb)	Command Register b (CRb)
1001 0010 (x92)	Interrupt Status Register b (ISRb)	Interrupt Mask Register b (IMRb)
1001 0011 (x93)	Receiver FIFO Reg b (RxFIFOb)	Transmitter FIFO Reg b (TxFIFOb)
1001 0100 (x94)	Reserved	✦ BRG Timer Reg Lower a (BRGTRLa)
1001 0100 (x94)	Input Port Reg b (IPRb)	Reserved
1001 0101 (x95)	I/O Port Interrupt and Output b (I/OPIORb)	I/O Port Interrupt and Output b (I/OPIORb)
1001 0110 (x96)	Xon/Xoff Interrupt Status Reg b (XISRb)	Reserved
1001 0111 (x97)	✦ GP Output Reg (GPOR)	✦ GP Output Reg (GPOR)
1001 1010 (x9A)	Reserved	Reserved
1001 1011 (x9B)	✦ GP Out Data Reg (GPOD)	✦ GP Out Data Reg (GPOD)
1001 1100 (x9C)	Reserved	✦ BRG Timer Control Reg (BRGCTCR)
1001 1100 (x9C)	✦ Global Interrupt Channel Reg (GICR)	Reserved
1001 1101 (x9D)	Reserved	✦ BRG Timer Reg Lower b (BRGTRLb)
1001 1101 (x9D)	✦ Global Interrupt Byte Count (GIBCR)	Reserved
1001 1110 (x9E)	Reserved	Reserved
1001 1111 (x9F)	✦ Global Interrupt Type Register (GITR)	Reserved

Octal UART for 3.3 V and 5 V supply voltage

SC28L198

A(7:0)	UART C	
	Read	Write
1010 0000 (xA0)	Mode Register c (MR2c)	Mode Register c (MR2c)
1010 0001 (xA1)	Status Register c (SRc)	Command Register c (CRc)
1010 0010 (xA2)	Interrupt Status Register c (ISRc)	Interrupt Mask Register c (IMRc)
1010 0011 (xA3)	Receiver FIFO Reg c (RxFIFOc)	Transmitter FIFO Reg c (TxFIFOc)
1010 0100 (xA4)	Input Port Reg c (IPRc)	Reserved
1010 0101 (xA5)	I/O Port Interrupt and Output c (I/OPIORc)	I/O Port Interrupt and Output c (I/OPIORc)
1010 0110 (xA6)	Xon/Xoff Interrupt Status Reg c (XISRc)	Reserved
1010 0111 (xA7)	Reserved	Reserved
1010 1000 (xA8)	Reserved	Reserved
1010 1001 (xA9)	Reserved	Reserved
1010 1010 (xAA)	Reserved	Reserved
1010 1011 (xAB)	Reserved	Reserved
1010 1100 (xAC)	Reserved	Reserved
1010 1101 (xAD)	Reserved	Reserved
1010 1110 (xAE)	Reserved	Reserved
1010 1111 (xAF)	Reserved	Reserved
A(7:0)	UART D	
	Read	Write
1011 0000 (xB0)	Mode Register d (MR2d)	Mode Register d (MR2d)
1011 0001 (xB1)	Status Register d (SRd)	Command Register d (CRd)
1011 0010 (xB2)	Interrupt Status Register d (ISRd)	Interrupt Mask Register d (IMRd)
1011 0011 (xB3)	Receiver FIFO Reg d (RxFIFOd)	Transmitter FIFO Reg d (TxFIFOd)
1011 0100 (xB4)	Input Port Reg d (IPRd)	Reserved
1011 0101 (xB5)	I/O Port Interrupt and Output d (I/OPIORd)	I/O Port Interrupt and Output d (I/OPIORd)
1011 0110 (xB6)	Xon/Xoff Interrupt Status Reg d (XISRd)	Reserved
1011 0111 (xB7)	Reserved	Reserved
1011 1000 (xBB)	Reserved	Reserved
1011 1001 (xB9)	Reserved	Reserved
1011 1010 (xBA)	Reserved	Reserved
1011 1011 (xBB)	Reserved	Reserved
1011 1100 (xBC)	Reserved	Reserved
1011 1101 (xBD)	Reserved	Reserved
1011 1110 (xBE)	Reserved	Reserved
1011 1111 (xBF)	Reserved	Reserved

Octal UART for 3.3 V and 5 V supply voltage

SC28L198

A(7:0)	Read	Write
UART E		
11000000 (xC0)	Mode Register e (MR2e)	Mode Register e (MR2e)
11000001 (xC1)	Status Register e (SRe)	Command Register e (CRe)
11000010 (xC2)	Interrupt Status Register e (ISRe)	Interrupt Mask Register e (IMRe)
11000011 (xC3)	Receiver FIFO Reg e (RxFIFOe)	Transmitter FIFO Reg e (TxFIFOe)
11000100 (xC4)	Input Port Reg e (IPRe)	Reserved
11000101 (xC5)	I/O Port Interrupt and Output e (I/OPIORe)	I/O Port Interrupt and Output e (I/OPIORe)
11000110 (xC6)	Xon/XoffInterrupt Status Reg e (XISRe)	Reserved
11000111 (xC7)	Reserved	Reserved
11001000 (xC8)	Reserved	Reserved
11001001 (xC9)	Reserved	Reserved
11001010 (xCA)	Reserved	Reserved
11001011 (xCB)	Reserved	Reserved
11001100 (xCC)	Reserved	Reserved
11001101 (xCD)	Reserved	Reserved
11001110 (xCE)	Reserved	Reserved
11001111 (xCF)	Reserved	Reserved
UART F		
11010000 (xD0)	Mode Register f (MR2f)	Mode Register f (MR2f)
11010001 (xD1)	Status Register f (SRf)	Command Register f (CRf)
11010010 (xD2)	Interrupt Status Register f (ISRf)	Interrupt Mask Register f (IMRf)
11010011 (xD3)	Receiver FIFO Reg f (RxFIFOf)	Transmitter FIFO Reg f (TxFIFOf)
11010100 (xD4)	Input Port Reg f (IPRf)	Reserved
11010101 (xD5)	I/O Port Interrupt and Output f (I/OPIORf)	I/O Port Interrupt and Output f (I/OPIORf)
11010110 (xD6)	Xon/XoffInterrupt Status Reg f (XISRf)	Reserved
11010111 (xD7)	Reserved	Reserved
11011000 (xD8)	Reserved	Reserved
11011001 (xD9)	Reserved	Reserved
11011010 (xDA)	Reserved	Reserved
11011011 (xDB)	Reserved	Reserved
11011100 (xDC)	Reserved	Reserved
11011101 (xDD)	Reserved	Reserved
11011110 (xDE)	Reserved	Reserved
11011111 (xDF)	Reserved	Reserved

Octal UART for 3.3 V and 5 V supply voltage

SC28L198

A(7:0)	Read	Write
UART G		
11100000 (xE0)	Mode Register g (MR2g)	Mode Register g (MR2g)
11100001 (xE1)	Status Register g (SRg)	Command Register g (CRg)
11100010 (xE2)	Interrupt Status Register g (ISRg)	Interrupt Mask Register g (IMRg)
11100011 (xE3)	Receiver FIFO Reg g (RxFIFOg)	Transmitter FIFO Reg g (TxFIFOg)
11100100 (xE4)	Input Port Reg g (IPRg)	Reserved
11100101 (xE5)	I/O Port Interrupt and Output g (I/OPIORg)	I/O Port Interrupt and Output g (I/OPIORg)
11100110 (xE6)	Xon/XoffInterrupt Status Reg g (XISRg)	Reserved
11100111 (xE7)	Reserved	Reserved
11101000 (xE8)	Reserved	Reserved
11101001 (xE9)	Reserved	Reserved
11101010 (xEA)	Reserved	Reserved
11101011 (xEB)	Reserved	Reserved
11101100 (xEC)	Reserved	Reserved
11101101 (xED)	Reserved	Reserved
11101110 (xEE)	Reserved	Reserved
11101111 (xEF)	Reserved	Reserved
UART H		
11110000 (xF0)	Mode Register h (MR2h)	Mode Register h (MR2h)
11110001 (xF1)	Status Register h (SRh)	Command Register h (CRh)
11110010 (xF2)	Interrupt Status Register h (ISRh)	Interrupt Mask Register h (IMRh)
11110011 (xF3)	Receiver FIFO Reg h (RxFIFOh)	Transmitter FIFO Reg h (TxFIFOh)
11110100 (xF4)	Input Port Reg h (IPRh)	Reserved
11110101 (xF5)	I/O Port Interrupt and Output h (I/OPIORh)	I/O Port Interrupt and Output h (I/OPIORh)
11110110 (xF6)	Xon/XoffInterrupt Status Reg h (XISRh)	Reserved
11110111 (xF7)	Reserved	Reserved
11111000 (xF8)	Reserved	Reserved
11111001 (xF9)	Reserved	Reserved
11111010 (xFA)	Reserved	Reserved
11111011 (xFB)	Reserved	Reserved
11111100 (xFC)	Reserved	Reserved
11111101 (xFD)	Reserved	Reserved
11111110 (xFE)	Reserved	Reserved
11111111 (xFF)	Reserved	Reserved

Octal UART for 3.3 V and 5 V supply voltage

SC28L198

RESET CONDITIONS

Device Configuration after Hardware Reset or CRA cmd=x1F

Cleared registers:

- Channel Status Registers (SR)
- Channel Interrupt Status Registers (ISR)
- Channel Interrupt Mask Registers (IMR)
- Channel Interrupt Xon Status Register (XISR)
- Interrupt Control Register (ICR)
- Global Configuration Control Register (GCCR)
- Hence the device enters the asynchronous bus cycling mode.
- Current Interrupt Register (CIR)
- BRG Timer Run Control Register (BRGTCCR)
- Watch-dog Timer Run Control Register (WDTRCR)
- Channel Input/Output Port Configuration Registers (I/OPCR)
- Hence all I/O pins have direction = Input after reset
- BRG Counter/Timer Registers

Clears Modes for:

- Power down

- Test modes
- Input Port Changed bits
- Gang write to Xon or Xoff
- Xon/Xoff/Address detection
- Receiver error status

Disables:

- Transmitters
- Receivers
- Interrupts, current and future

Halts:

- BRG Counters
- Bus cycle in progress (hardware RESET only)

Limitations:

Minimum RESETN pin pulse width is 10 SCIk cycles **after Vcc reaches operational range**

The user must allow a minimum of 6 SCIk cycles to elapse after a reset (RESETN pin or CRA initiated) of the device terminates before initiating a new bus cycle.

Octal UART for 3.3 V and 5 V supply voltage

SC28L198

DC ELECTRICAL SPECIFICATIONS FOR COMMERCIAL AND INDUSTRIAL (5V) $V_{CC} = 5.0$ volts $\pm 10\%$; $T_A = -40$ °C to $+85$ °C; unless otherwise specified

SYMBOL	PARAMETER	TEST CONDITIONS	LIMITS			UNIT
			MIN	TYP ¹	MAX	
V_{IL}	Input low voltage ²		V_{SS}		0.8	V
V_{IH}	Input high voltage (except X1/CLK)		2.0		V_{CC}	
V_{IH}	Input high voltage (X1/CLK)		$0.8V_{CC}$		V_{CC}	
V_{OL} ³	Output low voltage ⁴	$I_{OL} = 4.0$ mA		0.15	0.4	V
V_{OH}	Output high voltage (except OD outputs)	$I_{OH} = -400$ μ A	$0.8V_{CC}$			V
V_{OL} ³	Open Drain low voltage	$I_{OH} = -100$ μ A $I_{OL} = 14.0$ mA	$0.9V_{CC}$	<0.25	0.4	
I_{IL}	Input current low, I/O pins	$V_{IN} = 0$	-10	<0.1		μ A
I_{IH}	Input current high, I/O pins	$V_{IN} = V_{CC}$		<0.1	10	
I_L	Input leakage current	$V_{IN} = 0$ to V_{CC}	-5	<1	5	μ A
I_{ILCKX1}	X1/CLK input low current	$V_{IN} = V_{SS}, X2 = \text{Open}$	-450			μ A
I_{IHCKX1}	X1/CLK input high current	$V_{IN} = V_{CC}, X2 = \text{Open}$			450	
I_{OZH}	Output off current high, 3-state data bus	$V_{IN} = V_{CC}$		<.1	10	μ A
I_{OZL}	Output off current low, 3-state data bus	$V_{IN} = 0$	-10	<.1		μ A
I_{ODL}	Open-drain output low current in off state	$V_{IN} = 0$	-10	<.1		μ A
I_{ODH}	Open drain output high current in off state	$V_{IN} = V_{CC}$		<.1	10	
I_{CC}	Power supply current	TTL Input levels		100	150	mA
	Operating mode 33 MHz	CMOS input levels		26	40	mA
	Static Power down (No clocks, Open-drains off, inputs at V_{SS} or V_{CC})	CMOS input levels		0.6	5	μ A

NOTES:

1. Typical values are at $+25$ °C, typical supply voltage and typical processing parameters.
2. All voltage measurements are referenced to V_{SS} . For testing, all inputs swing between 0.4 V and 2.4 V with a transition time of 10 ns maximum. For X1/CLK this swing is between 0.4 V and 4.4 V. all time measurements are referenced at input voltages of V_{IL} and V_{IH} as appropriate.
3. Test conditions for interrupt and I/O outputs: CL = 50 pF. Test conditions for the rest of the outputs: CL = 60 pF.
4. Simultaneous switching more than 6 I/O port pins from 5 volts to 0 volts at full capacitive load may ground bounce on the output pins up to 0.95 volts.
5. All R_X , T_X , Brg Timer, I/O pins operating at 16 MHz. Sclk at 35 MHz and V_{CC} at 5.6 volts. A worst-case environment.

Octal UART for 3.3 V and 5 V supply voltage

SC28L198

AC ELECTRICAL CHARACTERISTICS FOR COMMERCIAL AND INDUSTRIAL (5V)V_{CC} = 5.0 volts ± 10%; T_A = -40 °C to +85°C; unless otherwise specified

SYMBOL	FIG #	PARAMETER	LIMIT			UNIT
			MIN	TYP	MAX	
Reset Timing						
t _{RES} ¹		RESET pulse width	10			Sclk
Bus Timing						
t _{AS}		A0–A7 setup time before Sclk C3 rising edge	10	2		ns
t _{AH}		A0–A7 hold time after Sclk C3 rising edge	18	8		ns
t _{CS}		CEN setup time before Sclk C1 high (Sync)	5	3		ns
		CEN setup time before Sclk C2 high (Async)	5	3		ns
t _{CH}		CEN hold time after Sclk C3 high (Sync)	14	1½Sclk		ns
		CEN hold time after Sclk C4 high (Async)	25	1½Sclk		ns
t _{STP}		CEN high before next C2 to stop next cycle (Sync Mode) ²	18			ns
t _{RWS}		W–Rn setup time before Sclk C2 rising edge	5			ns
t _{RWH}		W–Rn hold time after Sclk C3 rising edge	14	1½Sclk		ns
t _{DD}		Read cycle Data valid after Sclk C3 rising edge		12	25	ns
t _{DF}		Read cycle data bus floating after CEN high (Sync)		10	16	ns
		Read cycle data bus floating after C4 end high (Async)		10	15	ns
t _{DS}		Write cycle data setup time before Sclk C4 rising edge	25	14		ns
t _{DH}		Write cycle data hold time after Sclk C4 rising edge	15	8		ns
t _{RWD}		High time between CEN low (Async)	12	½ Sclk		ns
I/O Port Pin Timing						
t _{PS}		I/O input setup time before Sclk C3 rising edge	18	4		ns
t _{PH}		I/O input hold time after Sclk C4 rising edge	12	1		ns
t _{PD}		I/O output valid from: Write Sclk C4 rising edge (write to IOPIOR)		32	50	ns
Interrupt Timing						
t _{IR}		IRQN from: Internal interrupt source active bid	22	26	43	Sclk
		Reset to IRQN inactive			75	ns
		Write IMR (set or clear IMR bit) ³			45	ns
t _{DD}		IACKN cycle Data valid after Sclk C3 rising edge		12	25	ns
Tx/Rx Clock Timing						
t _{RX}		RxC high or low time	15	8		ns
F _{RX} ⁴		RxC frequency (16 X)	0		16	Mhz
		(1 X)	0		1	Mhz
t _{TX}		TxC high or low time	15	7		ns
F _{TX} ⁴		TxC frequency (16 X)	0		16	Mhz
		(1 X)	0		1	Mhz
Transmitter Timing						
t _{TXD}		TxD output delay from TxC low		32	60	ns
t _{tcs}		TxC output delay from TxD output data	-15	4	15	ns
Receiver Timing						
t _{RXS}		RxD data setup time to RxC high (data)	20	-4		ns
t _{RXH}		RxD data hold time from RxC high (data)	20	6		ns
t _{SSTRT}		RxD data low time for receiving a valid Start Bit	17/32			bit time

Octal UART for 3.3 V and 5 V supply voltage

SC28L198

AC ELECTRICAL CHARACTERISTICS FOR COMMERCIAL AND INDUSTRIAL (5 V) (Continued) $V_{CC} = 5.0 \text{ volts} \pm 10 \%$; $T_A = -40 \text{ }^\circ\text{C}$ to $+85 \text{ }^\circ\text{C}$; unless otherwise specified

SYMBOL	FIG#	PARAMETER	LIMITS			UNIT
			MIN	TYP	MAX	
Sclk Timing						
t_{sckl}		Min low time at V_{IL} (0.8V)	11	5		ns
t_{sckh}		Min high time at V_{IH} (2.0V)	11	5		ns
F_{sck}		Sclk frequency	0.1		33	MHz
t_{RFsck}		Sclk rise and fall time (0.8 to 2.0Volts)			3	ns
X1/X2 Communication Crystal Clock						
F_{x1}^5		X1 clock frequency	1	3.6864	8.0	MHz
X1 L / H		X1 Low / High time	32	135		ns
T/RFx1		X1 Rise and Fall time			10	ns
Counter/Timer Baud Rate Clock (External Clock Input)						
FC/T^4		Clock frequency	0		8	MHz
TC/TLH		C/T high and low time	15	11		ns
TC/TO		Delay C/T clock external to output pin		48	60	ns
DTACK Timing						
DAKdly		DACK low from Sclk C4 rising edge		10	18	ns
DAKdlya		DACK high from CEN high (Async)		11	20	ns
DAKdlys		DACK high from C4 end rising edge (Sync)		11	20	ns
I/O Port External Clock						
tgpirtx		GPI to Rx/Tx clock out		32	50	ns
		RxD setup to I/OP rising edge 1X mode	20	2		ns
		I/OP falling edge to TxD out 1X mode		32	60	ns
Gout Timing						
GPOtd		GPO valid after write to GPOR		100		ns

NOTES:

- Timing is illustrated and referenced with respect to $W-RN$ and CEN inputs. Internal read and write activities are controlled by the Sclk as it generates the several "C" timing as shown in the timing diagrams.
- The minimum time before the rising edge of the next C2 time to stop the next bus cycle. CEN must return high after midpoint of C4 time and before the C2 time of the next cycle.
- Delay is from CEN high in Async mode to $IRQN$ inactive, from end of C4 to $IRQN$ inactive in Sync mode.
- The minimum frequency values are not tested, but are guaranteed by design.
- 1MHz specification is for crystal operation.

Octal UART for 3.3 V and 5 V supply voltage

SC28L198

DC ELECTRICAL SPECIFICATIONS FOR COMMERCIAL AND INDUSTRIAL (3.3 V) $V_{CC} = 3.3 \text{ volts} \pm 10\%$; $T_A = -40 \text{ }^\circ\text{C}$ to $+85\text{ }^\circ\text{C}$; unless otherwise specified

SYMBOL	PARAMETER	TEST CONDITIONS	LIMITS			UNIT
			MIN	TYP ¹	MAX	
V_{IL}	Input low voltage ²		V_{SS}		$0.2 * V_{CC}$	V
V_{IH}	Input high voltage (except X1/CLK)		$0.8 * V_{CC}$		V_{CC}	
V_{IH}	Input high voltage (X1/CLK)		$0.8 * V_{CC}$		V_{CC}	
V_{OL} ³	Output low voltage ⁴	$I_{OL} = 3.2\text{mA}$		0.15	0.4	V
V_{OH}	Output high voltage (except OD outputs)	$I_{OH} = -400\mu\text{A}$	$0.8V_{CC}$			
V_{OL} ³	Open Drain low voltage	$I_{OH} = -100\mu\text{A}$ $I_{OL} = 10.0\text{mA}$	$0.9V_{CC}$	<0.25	0.4	V
I_{IL}	Input current low, I/O pins	$V_{IN} = 0$	-5	<0.1		μA
I_{IH}	Input current high, I/O pins	$V_{IN} = V_{CC}$		<0.1	+5	μA
I_L	Input leakage current	$V_{IN} = 0$ to V_{CC}	-5	<1	5	μA
I_{ILCKX1}	X1/CLK input low current	$V_{IN}=V_{SS}, X2=Open$	-300			μA
I_{IHCKX1}	X1/CLK input high current	$V_{IN}=V_{CC}, X2=Open$			300	μA
I_{OZH}	Output off current high, 3-state data bus	$V_{IN} = V_{CC}$		<.1	5	μA
I_{OZL}	Output off current low, 3-state data bus	$V_{IN} = 0$	-5	<.1		μA
I_{ODL}	Open-drain output low current in off state	$V_{IN} = 0$	-5	<.1		μA
I_{ODH}	Open drain output high current in off state	$V_{IN} = V_{CC}$		<.1	5	μA
I_{CC}	Power supply current	TTL Input levels		22	35	mA
	Operating mode 33 MHz	CMOS input levels		12	20	mA
	Static Power down (No clocks, Open drains off, inputs at V_{SS} or V_{CC})	CMOS input levels		0.6	5	μA

NOTES:

1. Typical values are at $+25 \text{ }^\circ\text{C}$, typical supply voltage and typical processing parameters.
2. All voltage measurements are referenced to V_{SS} . For testing, all inputs swing between 0.4 V and 2.4 V with a transition time of 10 ns maximum. For X1/CLK this swing is between 0.2V and 2.88V. all time measurements are referenced at input voltages of V_{IL} and V_{IH} as appropriate.
3. Test conditions for interrupt and I/O outputs: $C_L = 50 \text{ pF}$. Test conditions for the rest of the outputs: $C_L = 60 \text{ pF}$.
4. Simultaneous switching more than 6 I/O port pins from 5 volts to 0 volts at full capacitive load may ground bounce on the output pins up to 0.95 volts.
5. All R_X , T_X , Brg Timer, I/O pins operating at 16 MHz. Sclk at 35 MHz and V_{CC} at 5.6 volts. A worst-case environment.

Octal UART for 3.3 V and 5 V supply voltage

SC28L198

AC ELECTRICAL CHARACTERISTICS FOR COMMERCIAL AND INDUSTRIAL (3.3 V)V_{CC} = 3.3 volts ± 10%; T_A = -40 °C to +85°C; unless otherwise specified

SYMBOL	FIGURE	PARAMETER	LIMITS			UNIT
			MIN	TYP	MAX	
Reset Timing						
t _{RES} ¹		RESET pulse width	10			Sclk
Bus Timing						
t _{AS}		A0-A7 setup time before Sclk C3 rising edge	22	3		ns
t _{AH}		A0-A7 hold time after Sclk C3 rising edge	30	12		ns
t _{CS}		CEN setup time before Sclk C1 high (ASYNC)	8	3		ns
		CEN setup time before Sclk C2 high (SYNC)	8	3		ns
t _{CH}		CEN hold time after Sclk C3 high (SYNC)	25	1½ Sclk		ns
		CEN hold time after Sclk C4 high (ASYNC)	50	1½ Sclk		ns
t _{STP}		Cen high before next C2 to stop next cycle (Sync Mode) ²	30			ns
t _{RWS}		W-Rn setup time before Sclk C2 rising edge	7			ns
t _{RWH}		W-Rn hold time after Sclk C3 rising edge	25	1½ Sclk		ns
t _{DD}		Read cycle Data valid after Sclk C3 falling edge		20	40	ns
t _{DF}		Read cycle data bus floating after CEN high (ASYNC)		17	30	ns
		Read cycle data bus floating after C4 end (SYNC)		11	20	ns
t _{DS}		Write cycle data setup time before Sclk C4 rising edge	25	14		ns
t _{DH}		Write cycle data hold time after Sclk C4 rising edge	25	14		ns
t _{RWD}		High time between CEN low (ASYNC)	15	½ Sclk		ns
I/O Port Pin Timing						
t _{PS}		I/O input setup time before Sclk C3 falling edge (Read IPR)	18	4		ns
t _{PH}		I/O input hold time after Sclk C4 rising edge (Read IPR)	12	4		ns
t _{PD}		I/O output valid from: Write Sclk C4 rising edge (write to I/OPIOR)		50	80	ns
Interrupt Timing						
t _{IR}		IRQN from: Internal interrupt source active bid	22	26	43	Sclk
		Software reset to IRQN inactive		60	90	ns
		Write IMR (set or clear IMR bit) ³ to IRQN inactive		40	60	ns
t _{DD}		Interrupt vector valid after C3 rising edge		20	30	ns
Tx / Rx Clock Timing, External						
t _{RX}		RxC high or low time	25	8		ns
f _{RX} ⁴		RxC frequency (16 X)	0		8	MHz
		(1 X)	0		1	MHz
t _{TX}		TxC high or low time	20	7		ns
f _{TX} ⁴		TxC frequency (16 X)	0		8.0	MHz
		(1 X)	0		1	MHz
Transmitter Timing						
t _{TXD}		TxD output delay from TxC low		50	90	ns
t _{TCS}		TxC output delay from TxD output data	-15	4	15	ns
Receiver Timing						
t _{RXS}		RxD data setup time to RxC high (data)	25	14		ns
t _{RXH}		RxD data hold time from RxC high (data)	25	14		ns
t _{SSTRT}		RxD data low time to for receiving a valid Start Bit	17 32			bit time
Sclk Timing						
t _{SCLKL}		Min low time at Vil (0.8V)	15	10		ns
t _{SCLKH}		Min high time at Vih (2.0V)	15	10		ns

Octal UART for 3.3 V and 5 V supply voltage

SC28L198

AC ELECTRICAL CHARACTERISTICS FOR COMMERCIAL AND INDUSTRIAL (3.3 V) (Continued)

SYMBOL	FIGURE	PARAMETER	LIMITS			UNIT
			MIN	TYP	MAX	
Fsclk		Sclk frequency	0.1		20	MHz
T/RFsclk		Sclk rise/fall time (0.8 to 2.0Volts)			5	ns
X1 / X2 Communication Crystal Clock						
Fx1 ⁵		X1 clock frequency	1	3.6864	4	MHz
X1 L / H		X1 Low / High time	80	52		ns
T/RFx1		X1 Rise / Fall time			10	ns
Counter/Timer Baud Rate Clock (External Clock Input)						
FC/T ⁴		Clock frequency	0		8	MHz
TC/TLH		C/T high and low time	20	15		ns
TC/TO		Delay C/T clock external to output pin		48	110	ns
DACKN Timing						
DAK _{DLY}		DACK low from Sclk C4 rising edge		18	30	ns
DAK _{DLYA}		DACK high from CEN high (ASYNC)		18	30	ns
DAK _{DLY}		DACK high from C4 end rising edge (SYNC)		20	30	ns
I/O PORT External Clock						
T _{GPIR TX}		GPI to Rx/Tx clock out		50	80	ns
		RxD setup to I/OP rising edge 1X mode	20	2		ns
		I/OP falling edge to TxD out 1X mode		32	70	ns
G_{OUT} Timing						
GPO _{TDD}		GPO valid after write to GPOR		100		ns

NOTES:

- Timing is illustrated and referenced with respect to W–RN and CEN inputs. Internal read and write activities are controlled by the Sclk as it generates the several “C” timing as shown in the timing diagrams.
- The minimum time before the rising edge of the next C2 time to stop the next bus cycle. CEN must return high after midpoint of C4 time and before the C2 time of the next cycle.
- Delay is from CEN high in Async mode to IRQN inactive, from end of C4 to IRQN inactive in Sync mode.
- The minimum frequency values are not tested, but are guaranteed by design.
- 1MHz specification is for crystal operation.

Octal UART for 3.3 V and 5 V supply voltage

SC28L198

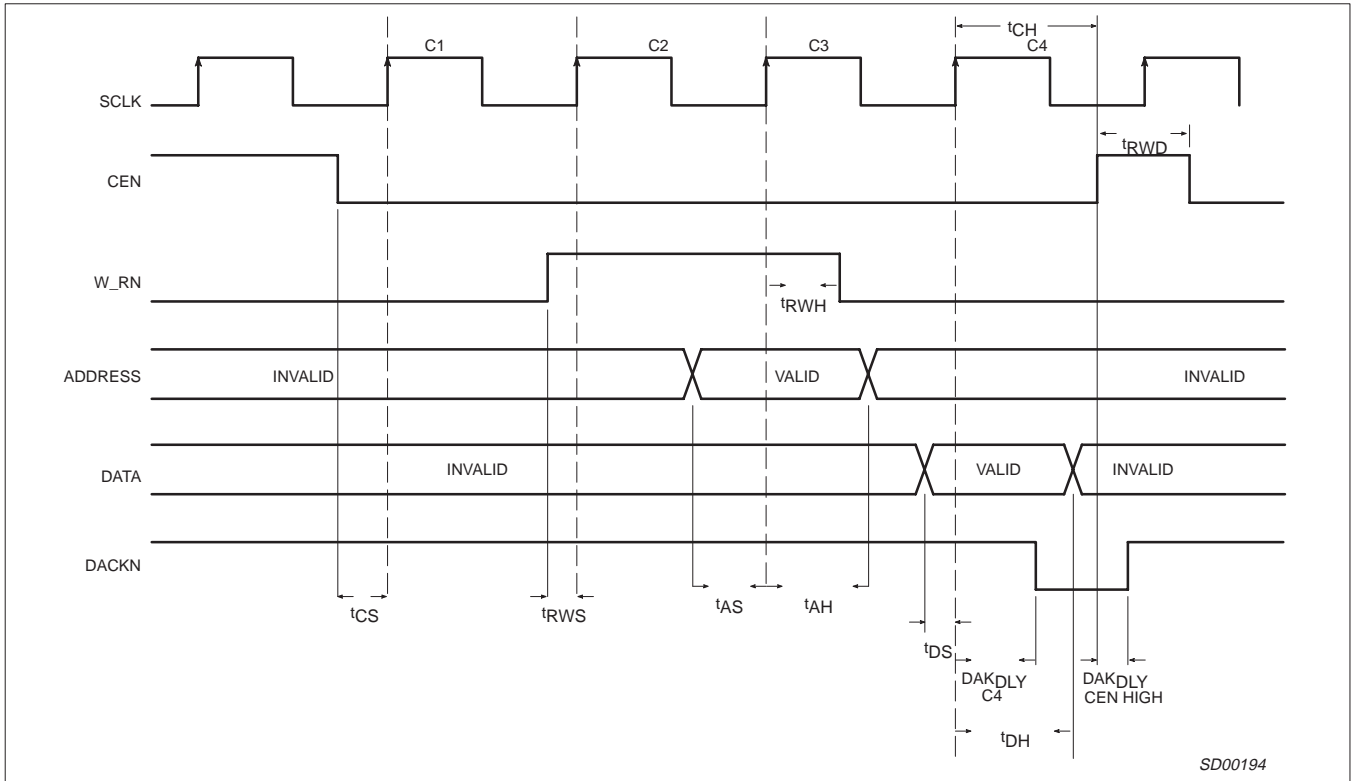

Figure 2. Basic Write Cycle, ASYNC

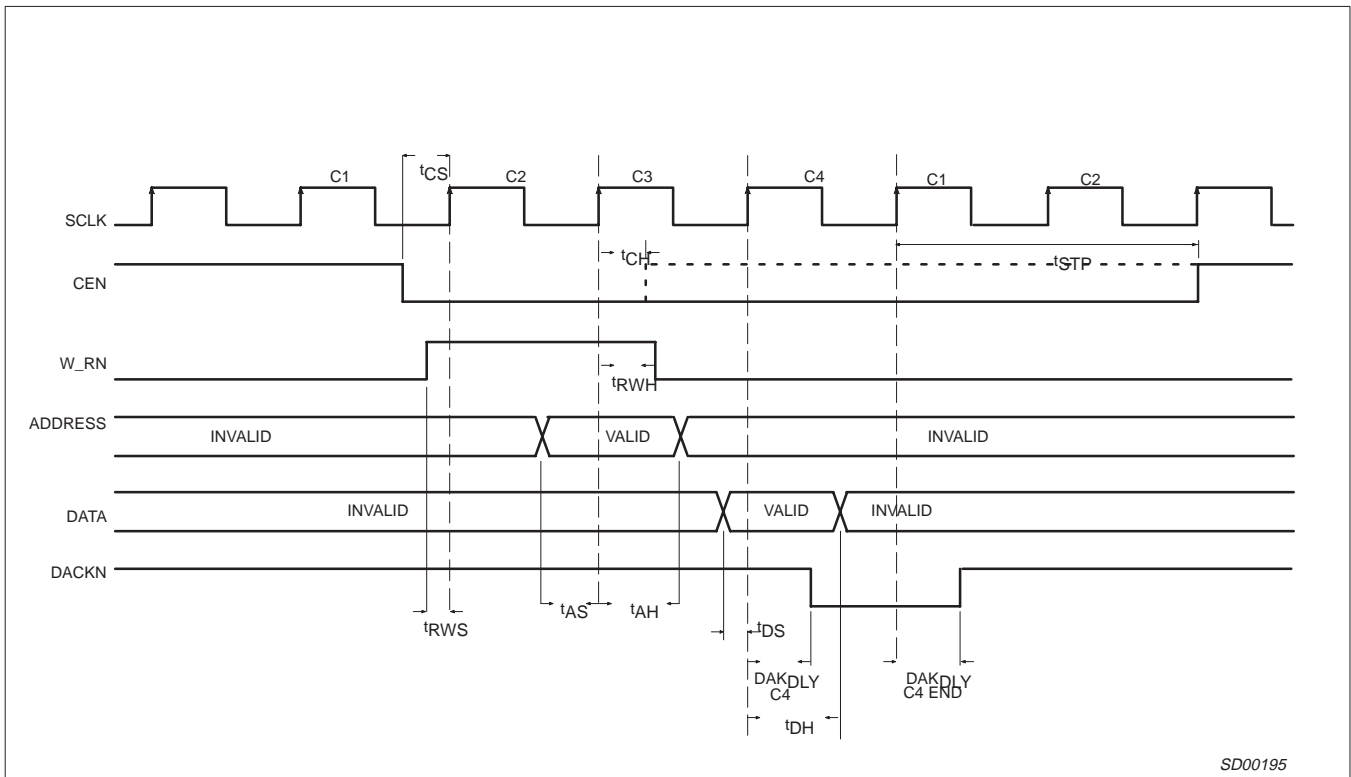

Figure 3. Basic Write Cycle, SYNC

Octal UART for 3.3 V and 5 V supply voltage

SC28L198

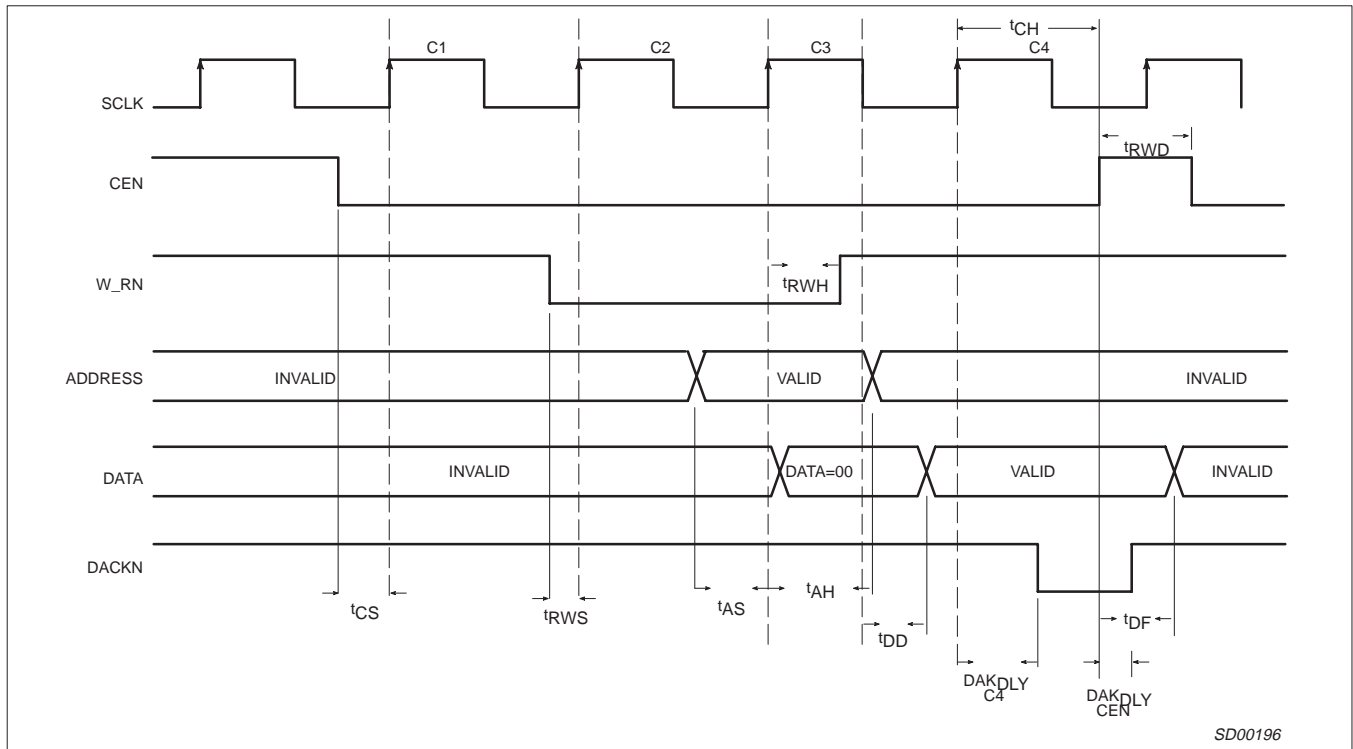

Figure 4. Basic Read Cycle, ASYNC

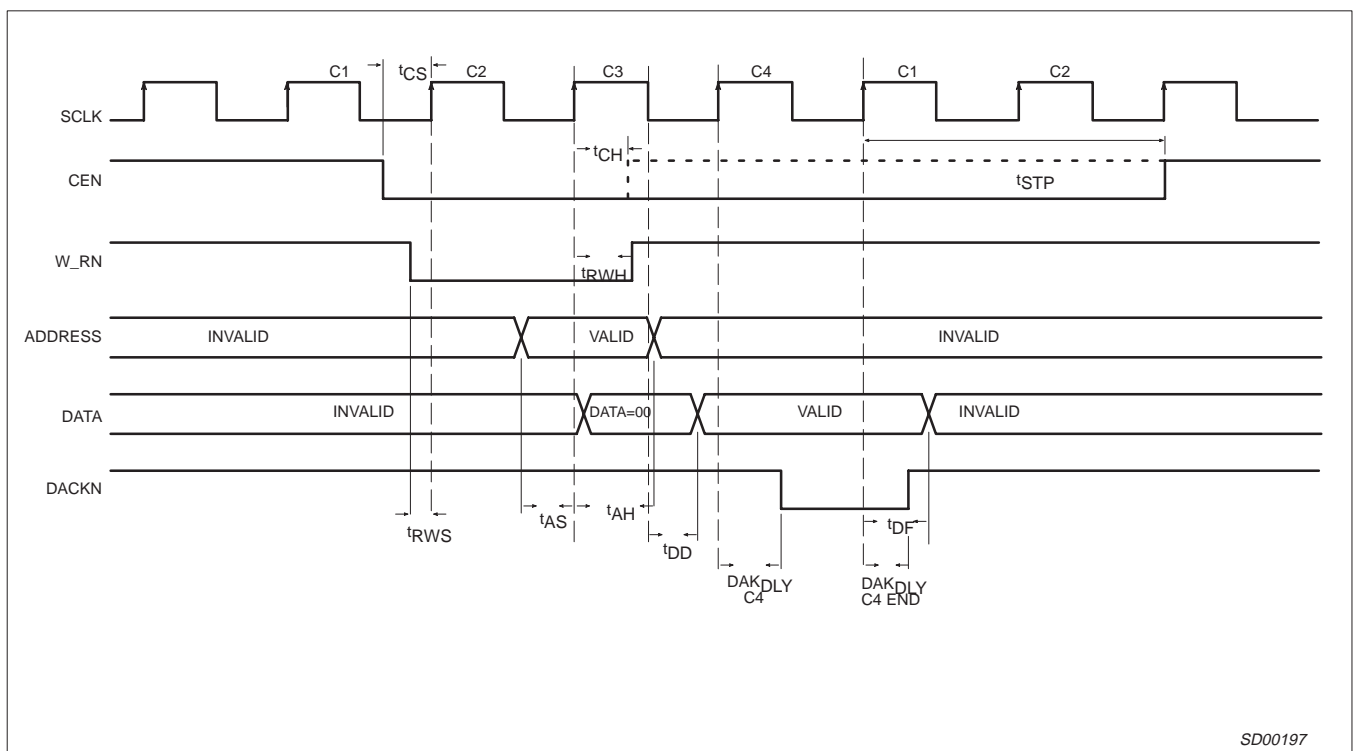

Figure 5. Basic Read Cycle, SYNC

Octal UART for 3.3 V and 5 V supply voltage

SC28L198

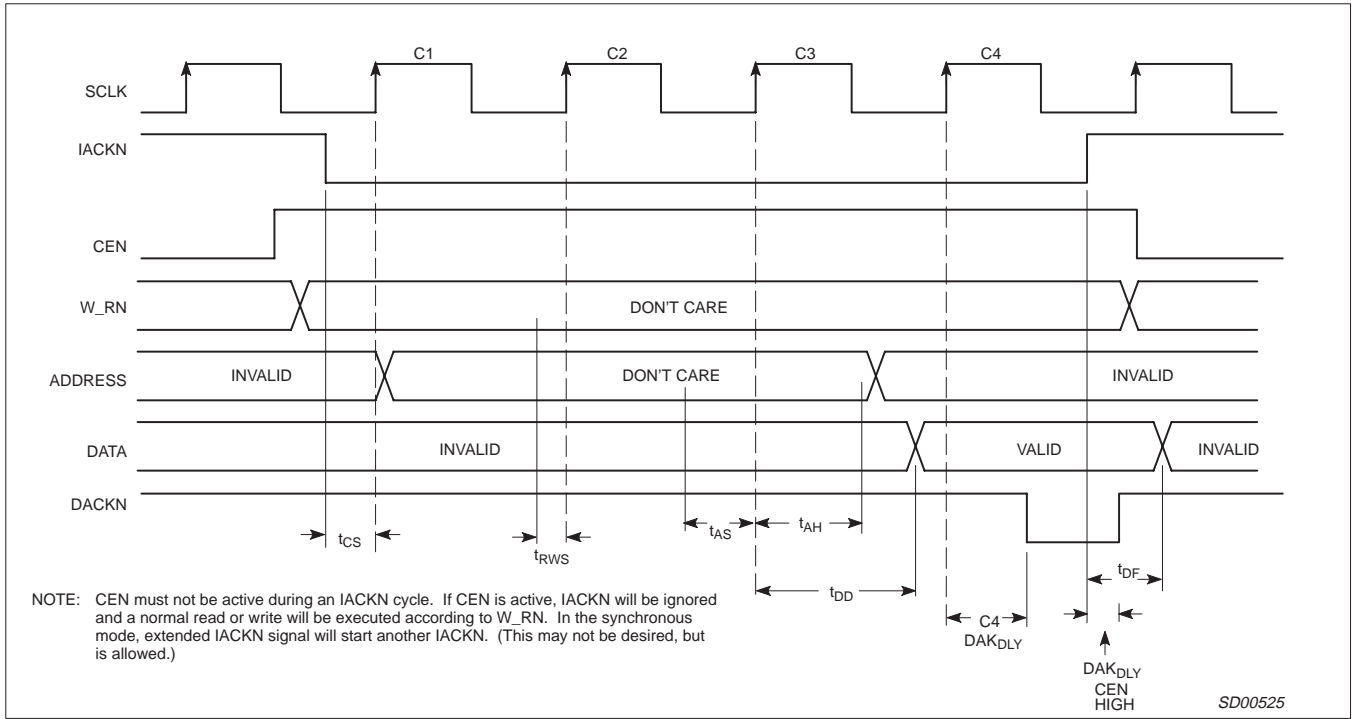

Figure 6. Basic IACKN Cycle, ASYNC/SYNC

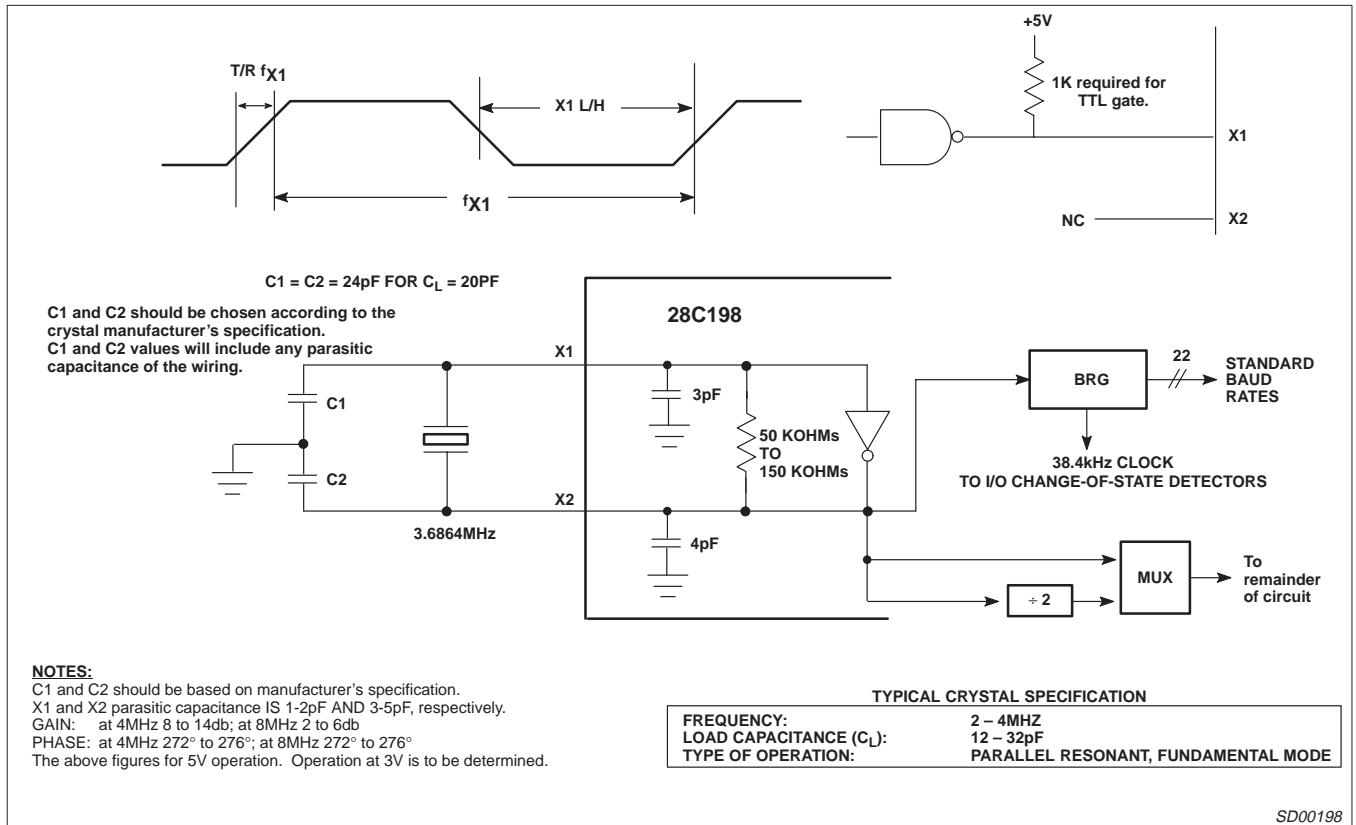

Figure 7. X1/X2 Communication Crystal Clock

Octal UART for 3.3 V and 5 V supply voltage

SC28L198

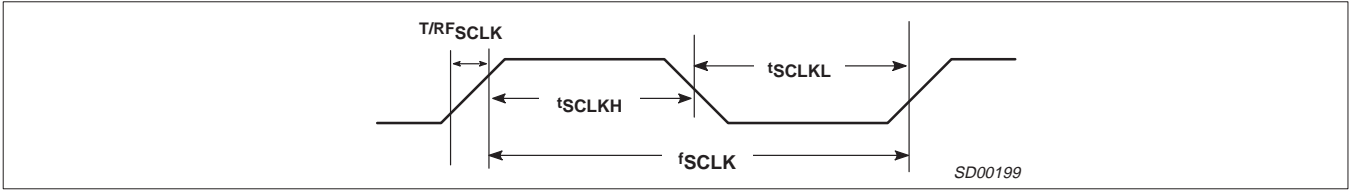

Figure 8. SCLK Timing

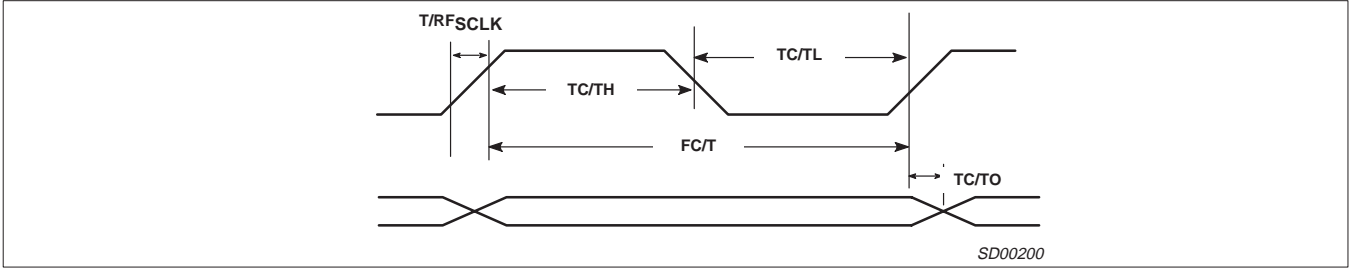

Figure 9. Counter/Timer Baud Rate Clock, External

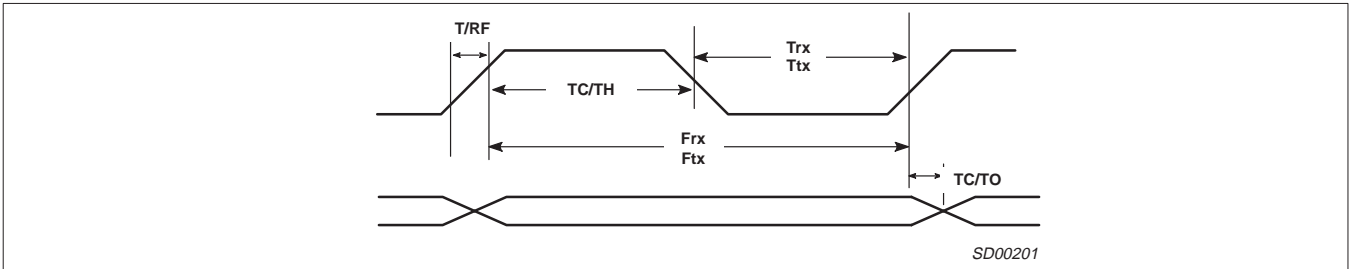

Figure 10. Tx/Rx Clock Timing, External

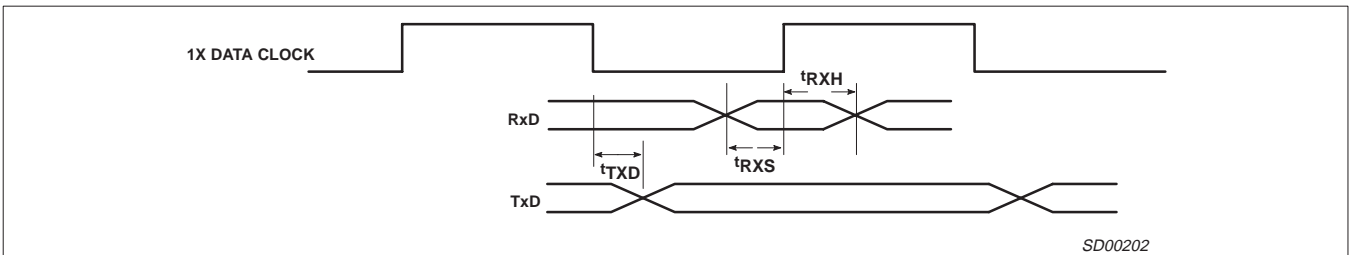

Figure 11. Transmitter and Receiver Timing

Note: CEN **must** not be active during an IACKN cycle. If CEN is active IACKN will be ignored and a normal read or write will be executed according to W_RN.

In the synchronous mode extended IACKN signal cycle will start another IACKN. (This may not be desired but is allowed)

Octal UART for 3.3 V and 5 V supply voltage

SC28L198

INDEX**Numbers**

1x and 16x modes, Receiver, 9
 1x and 16x modes, Transmitter, 9

A

Address Recognition Character Register, 25
 ARCR, 25
 Asynchronous bus cycle, 6

B

Baud Rate Generator , 7
 BCRA, 25
 BCRBRK, 24
 BCRBOS, 24
 BCRx, 24
 Bidding Control Register – Address, 25
 Bidding Control Register – Break Change, 24
 Bidding Control Register – Change of State, 24
 Bidding Control Register – Xon, 24
 Block diagram, 6
 Break, transmission of, 9
 BRG Timer Control Register, 26
 BRG Timer Reload Registers, Lower, 26
 BRG Timer Reload Registers, Upper, 26
 BRGCTCR , 26
 BRGTRL, 26
 BRGTRU, 26

C

CEN, 6
 Channel Blocks, 7
 Channel Status Register, 22
 Character Recognition, 7
 CharacterStripping, 11
 CIR, 27
 Clock Register, Rx & Tx, 20
 Command Register, 21
 COMMAND REGISTER TABLE, 22
 CR , 21
 Crystal oscillator, 7
 Current Interrupt Register, 27

D

Description, 2
 DESCRIPTION, over all, 6

F

Framing error, 10

G

GCCR, 17
 General Purpose Output Clk Register, 29
 General Purpose Output Data Register, 29
 General Purpose Output Register, 29
 General Purpose Output Select Register, 29
 General Purpose Pins, 11
 GIBCR, 28
 GICR, 27
 GITR, 28
 Global Configuration Control Register (GCCR), 17
 Global Interrupting Byte Count Register, 28
 Global Interrupting Channel Register, 27
 Global Registers, 8, 11
 Global Rx FIFO Register, 28
 Global Tx FIFO Register, 28

GPOC , 29
 GPOD, 29
 GPOR, 29
 GPOSR, 29
 GRxFIFO, 28
 GTxFIFO, 28

H

Host Interface, 6
 Host interface, 6

I

I/O Port Configuration Register, 29
 I/O Port Interrupt and Output Register, 28
 I/O ports, 10
 I/OPCR, 10, 29
 I/OPIOR, 28
 IACKN, 8
 IACKNCycle, 12
 ICR, 27
 IMR, 8, 24
 INDEX, 51
 Input Port Register, 28
 Interrupt Arbitration, 11
 Interrupt Control, 8
 Interrupt Mask Register, 24
 Interrupt priorities, Setting, 12
 Interrupt sources, Enabling, 12
 Interrupt Status Register, 23
 Interrupt Vector Register, 27
 Interrupts, Xon/Xoff, 16
 IOPIOR register, 11
 IPR , 28
 ISR, 8, 23
 IVR, 27

M

Minor Modes, 14
 Mode control, Xon/Xoff, 16
 Mode Register 0, 18
 Mode Register 1, 18
 Mode Register 2, 19
 Mode Registers, Initialization, 17
 Modes of Operation, 13
 MR0 , 18
 MR1, 18
 MR2, 19
 Multidrop mode, 11

O

Overrun error, 10

P

Parity error, 10
 Pin Description, 5
 Pinout, 4
 Polling, 12

R

Receiver, 9
 Receiver FIFO, 10, 24
 Receiver Status Bits, 9
 REGISTER DESCRIPTIONS, 17
 Register Map, 30
 Register Map, Control, 30, 31
 Register Map, Data, 31, 36
 Reset Conditions, 40
 RxCSR , 20
 Rx FIFO, 24

Octal UART for 3.3 V and 5 V supply voltage**SC28L198**

S

Sclk, 6
SR , 22
Synchronous bus cycle, 6
System Clock, 7

T

Timing Circuits, 6
Transmitter, 8
Transmitter FIFO, 9, 24
Tx, Status Bits , 8
TxCSR , 20
TxEMT, 8
TxFIFO, 24
TxRDY, 8

U

UCIR, 27
Update CIR, 12, 27

W

Wake Up Mode, 14
Wake up mode, 11
Wake Up modes, 14
Wake up. Default, 14
Watch-dog Timer , 14
Watch-dog Timer Enable Register, 26
WDTRCR, 26

X

XISR, 26
Xoff Character Register, 25
XoffCR, 25
Xon /Xoff characters , 15
Xon Character Register, 25
Xon-Xoff Interrupt Status Register, 26
Xon/Xoff modes, 15
Xon/Xoff Operation, 15
XonCR , 25

Octal UART for 3.3 V and 5 V supply voltage

SC28L198

PLCC84: plastic leaded chip carrier; 84 leads

SOT189-2

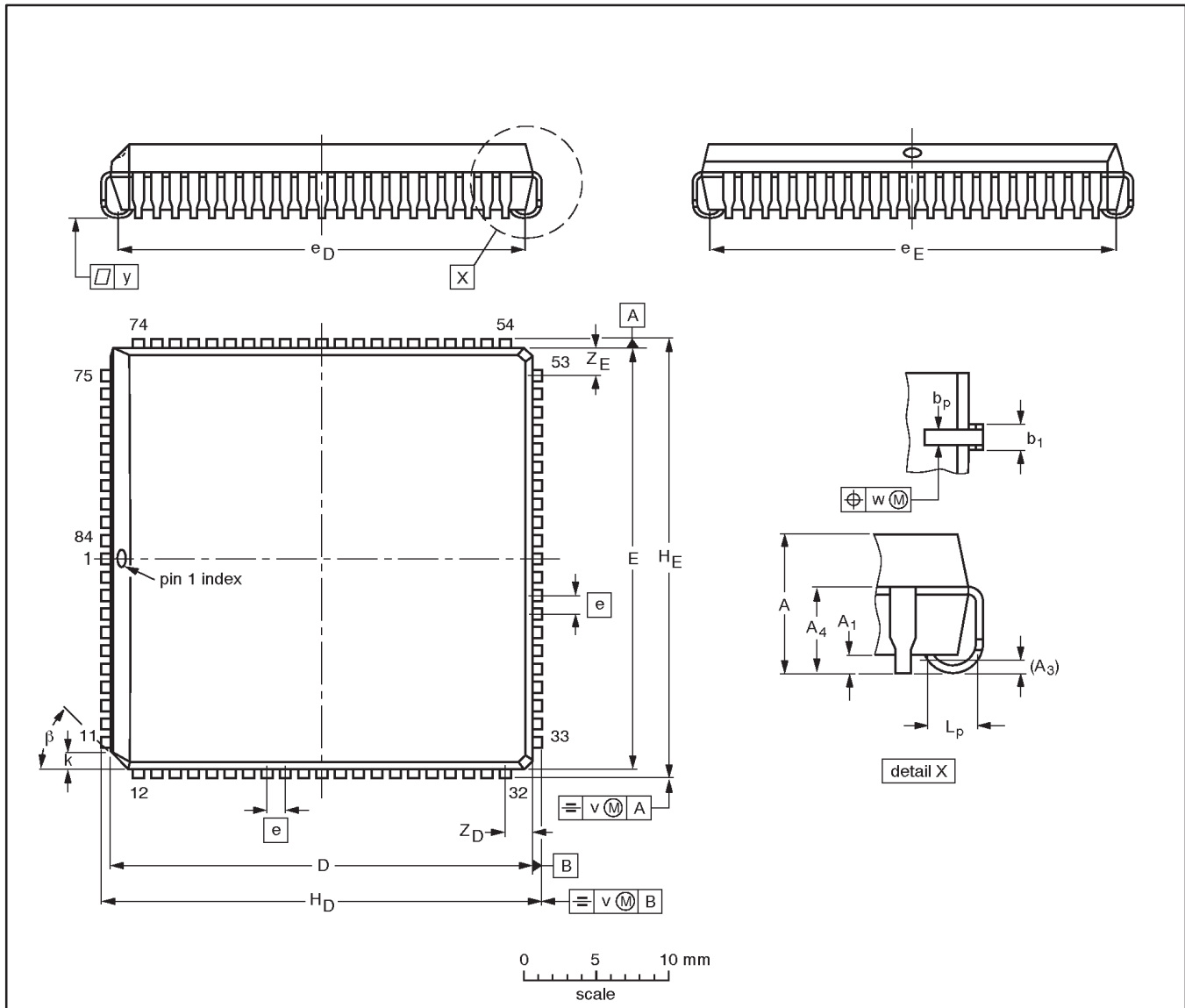

DIMENSIONS (mm dimensions are derived from the original inch dimensions)

UNIT	A	A ₁ min.	A ₃	A ₄ max.	b _p	b ₁	D ⁽¹⁾	E ⁽¹⁾	e	e _D	e _E	H _D	H _E	k	L _p	v	w	y	Z _D ⁽¹⁾ max.	Z _E ⁽¹⁾ max.	β
mm	4.57 4.19	0.51	0.25	3.30	0.53 0.33	0.81 0.66	29.41 29.21	29.41 29.21	1.27	28.70 27.69	28.70 27.69	30.35 30.10	30.35 30.10	1.22 1.07	1.44 1.02	0.18	0.18	0.1	2.16	2.16	45°
inches	0.180 0.165	0.02	0.01	0.13	0.021 0.013	0.032 0.026	1.158 1.150	1.158 1.150	0.05	1.13 1.09	1.13 1.09	1.195 1.185	1.195 1.185	0.048 0.042	0.057 0.040	0.007	0.007	0.004	0.085	0.085	

Note

1. Plastic or metal protrusions of 0.25 mm (0.01 inch) maximum per side are not included.

OUTLINE VERSION	REFERENCES				EUROPEAN PROJECTION	ISSUE DATE
	IEC	JEDEC	JEITA			
SOT189-2	112E13	MS-018	EDR-7319			99-12-27 01-11-14

Octal UART for 3.3 V and 5 V supply voltage

SC28L198

LQFP100: plastic low profile quad flat package; 100 leads; body 14 x 14 x 1.4 mm

SOT407-1

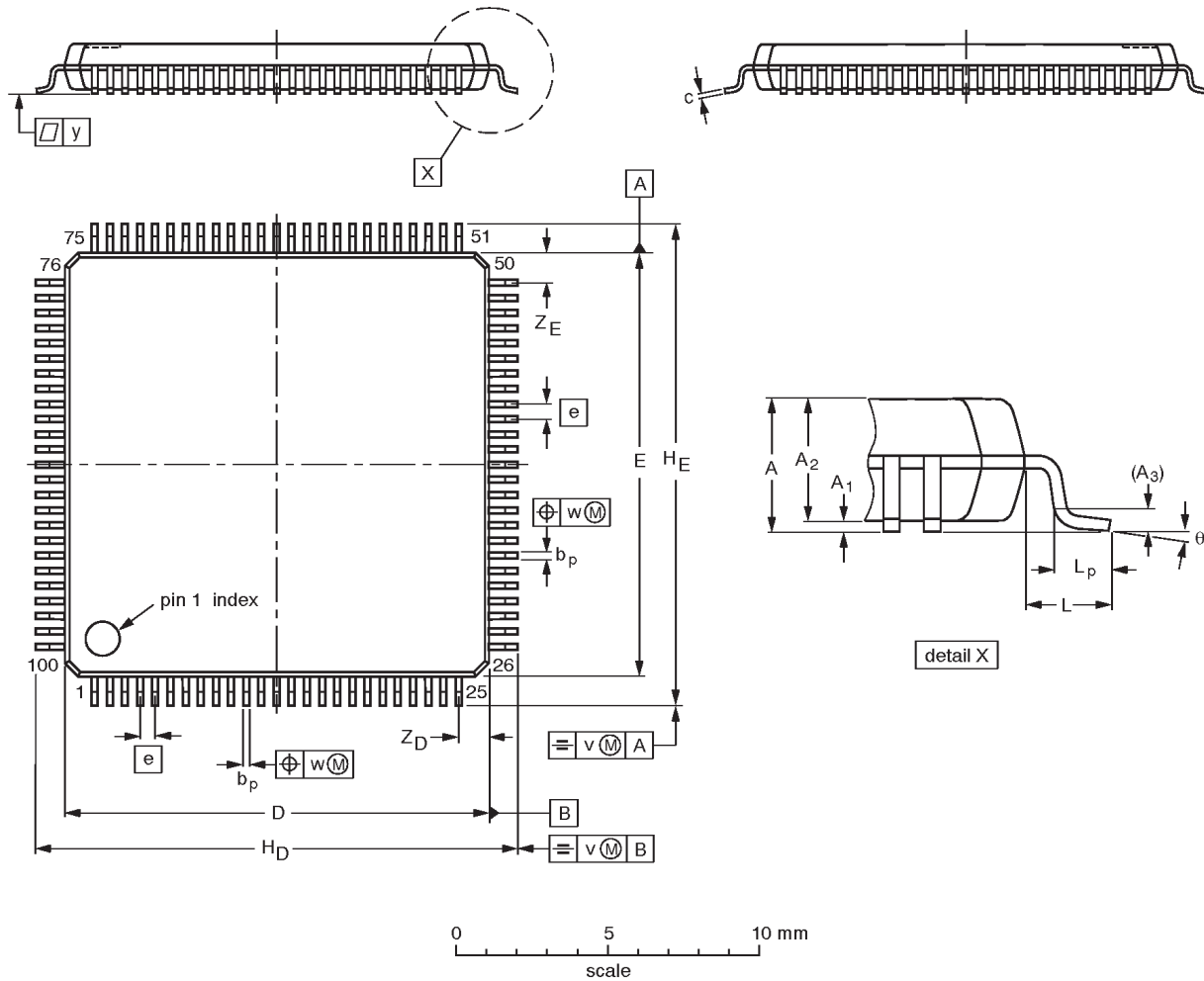

DIMENSIONS (mm are the original dimensions)

UNIT	A max.	A ₁	A ₂	A ₃	b _p	c	D ⁽¹⁾	E ⁽¹⁾	e	H _D	H _E	L	L _p	v	w	y	Z _D ⁽¹⁾	Z _E ⁽¹⁾	θ
mm	1.6	0.15 0.05	1.45 1.35	0.25	0.27 0.17	0.20 0.09	14.1 13.9	14.1 13.9	0.5	16.25 15.75	16.25 15.75	1	0.75 0.45	0.2	0.08	0.08	1.15 0.85	1.15 0.85	7° 0°

Note

1. Plastic or metal protrusions of 0.25 mm maximum per side are not included.

OUTLINE VERSION	REFERENCES				EUROPEAN PROJECTION	ISSUE DATE
	IEC	JEDEC	JEITA			
SOT407-1	136E20	MS-026				00-02-01- 03-02-20

Octal UART for 3.3 V and 5 V supply voltage

SC28L198

REVISION HISTORY

Rev	Date	Description
_6	20060810	Product data sheet (9397 750 14852). Supersedes data of 1999 Jan 14 (9397 750 04754). Modifications: <ul style="list-style-type: none">● Ordering information table: changed DWG # SOT189-3 to SOT189-2● Package outline drawing SOT189-3 replaced with SOT189-2
_5	19990114	Product specification (9397 750 04754). ECN #853-2047 20654. Supersedes data of 1998 Nov 04.
_4	19981104	Preliminary specification (9397 750 04754). Supersedes data of 1998 Sep 21.
_3	19980921	Preliminary specification (9397 750 04366). Replaces data sheet SC28C198_SC28L198_2 of of 1998 Feb 06.

Octal UART for 3.3 V and 5 V supply voltage

SC28L198

Legal Information

Data sheet status

Document status ^{[1][2]}	Product status ^[3]	Definition
Objective [short] data sheet	Development	This document contains data from the objective specification for product development.
Preliminary [short] data sheet	Qualification	This document contains data from the preliminary specification.
Product [short] data sheet	Production	This document contains the product specification.

[1] Please consult the most recently issued document before initiating or completing a design.

[2] The term 'short data sheet' is explained in section "Definitions".

[3] The product status of device(s) described in this document may have changed since this data sheet was published and may differ in case of multiple devices. The latest product status information is available on the Internet at URL <http://www.semiconductors.philips.com>.

Definitions

Draft — The document is a draft version only. The content is still under internal review and subject to formal approval, which may result in modifications or additions. Philips Semiconductors does not give any representations or warranties as to the accuracy or completeness of information included herein and shall have no liability for the consequences of use of such information.

Short data sheet — A short data sheet is an extract from a full data sheet with the same product type number(s) and title. A short data sheet is intended for quick reference only and should not be relied upon to contain detailed and full information. For detailed and full information see the relevant full data sheet, which is available on request via the local Philips Semiconductors sales office. In case of any inconsistency or conflict with the short data sheet, the full data sheet shall prevail.

Disclaimers

General — Information in this document is believed to be accurate and reliable. However, Philips Semiconductors does not give any representations or warranties, expressed or implied, as to the accuracy or completeness of such information and shall have no liability for the consequences of use of such information.

Right to make changes — Philips Semiconductors reserves the right to make changes to information published in this document, including without limitation specifications and product descriptions, at any time and without notice. This document supersedes and replaces all information supplied prior to the publication hereof.

Suitability for use — Philips Semiconductors products are not designed, authorized or warranted to be suitable for use in medical, military, aircraft, space or life support equipment, nor in applications where failure or malfunction of a Philips Semiconductors product can reasonably be expected to result in personal injury, death or severe property or

environmental damage. Philips Semiconductors accepts no liability for inclusion and/or use of Philips Semiconductors products in such equipment or applications and therefore such inclusion and/or use is at the customer's own risk.

Applications — Applications that are described herein for any of these products are for illustrative purposes only. Philips Semiconductors makes no representation or warranty that such applications will be suitable for the specified use without further testing or modification.

Limiting values — Stress above one or more limiting values (as defined in the Absolute Maximum Ratings System of IEC 60134) may cause permanent damage to the device. Limiting values are stress ratings only and operation of the device at these or any other conditions above those given in the Characteristics sections of this document is not implied. Exposure to limiting values for extended periods may affect device reliability.

Terms and conditions of sale — Philips Semiconductors products are sold subject to the general terms and conditions of commercial sale, as published at <http://www.semiconductors.philips.com/profile/terms>, including those pertaining to warranty, intellectual property rights infringement and limitation of liability, unless explicitly otherwise agreed to in writing by Philips Semiconductors. In case of any inconsistency or conflict between information in this document and such terms and conditions, the latter will prevail.

No offer to sell or license — Nothing in this document may be interpreted or construed as an offer to sell products that is open for acceptance or the grant, conveyance or implication of any license under any copyrights, patents or other industrial or intellectual property rights.

Trademarks

Notice: All referenced brands, product names, service names and trademarks are the property of their respective owners.

Contact information

For additional information please visit: <http://www.semiconductors.philips.com>

For sales office addresses, send an e-mail to: sales.addresses@www.semiconductors.philips.com

Please be aware that important notices concerning this document and the product(s) described herein, have been included in section "Legal information".



© Koninklijke Philips Electronics N.V. 2006. All rights reserved.
For more information, please visit <http://www.semiconductors.philips.com>.
For sales office addresses, email to: sales.addresses@www.semiconductors.philips.com.

Date of release: 20060810

Document identifier: SC28L198_6

Mouser Electronics

Authorized Distributor

Click to View Pricing, Inventory, Delivery & Lifecycle Information:

[NXP:](#)

[SC28L198A1A,512](#) [SC28L198A1A,529](#) [SC28L198A1A,518](#) [SC28L198A1BE,557](#) [SC28L198A1BE,551](#)
[SC28L198A1BE,528](#)

Компания «Life Electronics» занимается поставками электронных компонентов импортного и отечественного производства от производителей и со складов крупных дистрибьюторов Европы, Америки и Азии.

С конца 2013 года компания активно расширяет линейку поставок компонентов по направлению коаксиальный кабель, кварцевые генераторы и конденсаторы (керамические, пленочные, электролитические), за счёт заключения дистрибьюторских договоров

Мы предлагаем:

- Конкурентоспособные цены и скидки постоянным клиентам.
- Специальные условия для постоянных клиентов.
- Подбор аналогов.
- Поставку компонентов в любых объемах, удовлетворяющих вашим потребностям.
- Приемлемые сроки поставки, возможна ускоренная поставка.
- Доставку товара в любую точку России и стран СНГ.
- Комплексную поставку.
- Работу по проектам и поставку образцов.
- Формирование склада под заказчика.
- Сертификаты соответствия на поставляемую продукцию (по желанию клиента).
- Тестирование поставляемой продукции.
- Поставку компонентов, требующих военную и космическую приемку.
- Входной контроль качества.
- Наличие сертификата ISO.

В составе нашей компании организован Конструкторский отдел, призванный помогать разработчикам, и инженерам.

Конструкторский отдел помогает осуществить:

- Регистрацию проекта у производителя компонентов.
- Техническую поддержку проекта.
- Защиту от снятия компонента с производства.
- Оценку стоимости проекта по компонентам.
- Изготовление тестовой платы монтаж и пусконаладочные работы.



Тел: +7 (812) 336 43 04 (многоканальный)
Email: org@lifeelectronics.ru