

Telephone Line Interface and Speakerphone Circuit AS2522B

Key Features

- Line/Speech circuit, DTMF dialer, FSK transmitter and tone ringer on a 32-pin CMOS-IC
- Enhanced voice switching
- Background noise monitoring
- DTMF tone generator
- FSK Transmitter V.23, BELL202, V.21, BELL 103
- Ringer tone programmable
- Tx- and Rx-gain programmable
- Digital volume control of Rx signals
- DC characteristic programmable
- Dual softclipping in handset mode
- Tx-softclipping in handsfree mode
- Common monitor amplifier for loudhearing, handsfree and ringing
- Supply voltage generation for external circuitry
- Automatic line loss compensation (LLC)
- Real and complex impedance selectable by external components
- Side tone adaptation selectable by external components
- Unique EMC performance
- Operating range from 15mA to 100mA (down to 5mA with reduced performance)
- Few external components

General Description

AS2522 is a CMOS integrated circuit that incorporates DC and AC line adaptation (DC-mask and synthesized AC-impedance of 1000Ω) as well as a speech circuit with softclipping, line loss compensation and Rx-volume control for handset and handsfree operation. It shall act as an a/b-line powered device, which is controlled by a CPU via a serial interface. Furthermore the AS2522 incorporates a DTMF, FSK transmitter, single tone and ringer tone generator.

AS2522 allows to use an off-the-shelf microprocessor without special blocks and functions for telephone applications. DTMF, FSK transmitter, single tone and ringer tone generator can be controlled via the serial interface as well as the gain settings in handset and handsfree mode.

Applications

Enhanced handsfree feature phones with CallerID and extended displays.

Package

Available in 32-pin TQFP

Block Diagram

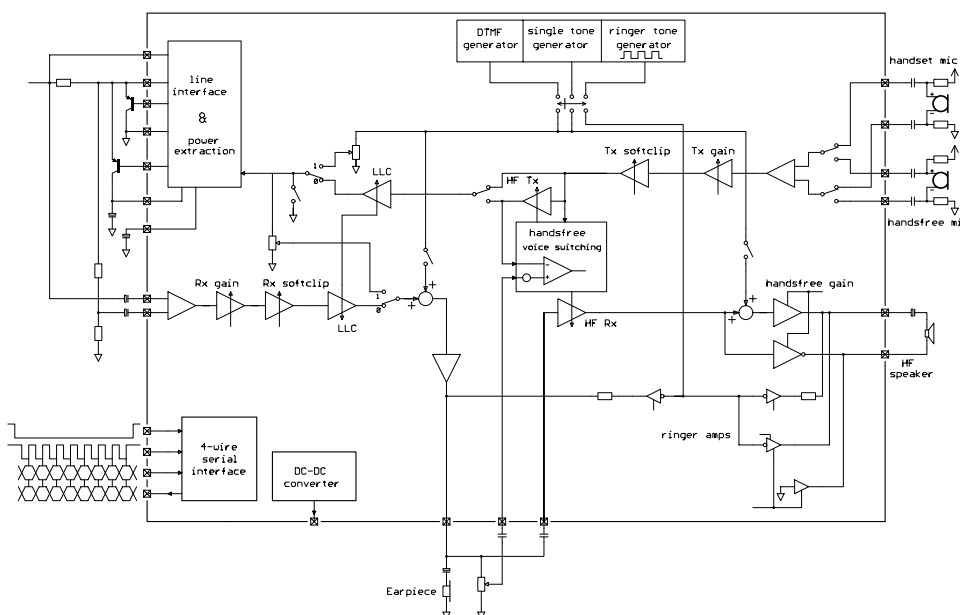

Pin description

Pin #	Symbol	Function
13	LS	Line Current Sense Input Analog input for sensing the line current
10	LI	Line Input Analog input used for power extraction and line current sensing
11	RI	Receive Input Analog input for ac-separated receive signal
7	STB	Side Tone Balance Input Analog input for side tone cancellation network
8	CS	Current Shunt Control Output N-channel open drain output to control the external high power shunt transistor for synthesizing AC- and DC-impedance, modulation of line voltage and shorting the line during make periods of pulse dialing
14	CI	Complex Impedance Input Analog input pin for the capacitor to program a complex impedance
12	SS	Supply Source Control Output N-channel open drain output to control the external high power source transistor for supplying (Vpp) the loudspeaker amplifier in off-hook loudspeaking/handsfree mode
9	VSS	Voltage Source Source Negative Analog Power Supply
18	VDD	Voltage Drain Drain Positive Analog Power Supply
19	AGND	Analog Ground Special ground for the internal amplifiers
6	M1	Microphone Input 1 Differential input for the handset microphone (electret)
4	M2	Microphone Input 2 Differential input for the handset microphone (electret)
5	M3	Microphone Input 3 Differential input for the handsfree microphone (electret)
3	M4	Microphone Input 4 Differential input for the handsfree microphone (electret)
17	RO	Receive Output to Handset Output for driving a dynamic earpiece with an impedance from 150Ω to 300Ω
31	OSC	Oscillator Input Input for ceramic resonator 3.58MHz.

Pin #	Symbol	Function
22	VPP	Loudspeaker Power Supply High power supply for the output driver stage
21	CM	Converter Make Output This is an output for controlling the external switching converter. During ringing it converts the ring signal into a 4V supply voltage
27	xCS	Chip Select Chip select input of the serial interface. Internal pull-up resistor (100kOhm)
29	DI	Data Input Data input of the serial interface. Internal pull-up resistor (100kOhm)
30	CLK	Clock Clock input of the serial interface. Internal pull-up resistor (100kOhm)
28	DO	Data Output Data output of the serial interface. If xCS=1 DO is in HI-Z state
24 23	LO1 LO2	Loudspeaker Output 1 and 2 Output pins for a 50Ω loudspeaker
1	FT1	Analog input pin for connecting a capacitor for offset cancellation.
2	FT2	Analog input pin for connecting a capacitor for offset cancellation.
20	CBN	Analog input pin for connecting a capacitor for background noise monitoring.
15	RECI	Analog input for the handsfree receive path. Should be connected to RO via coupling capacitor.
16	RECV	Analog input for receive voice switching path.
25	VSSA	Power supply pin for LS1-LS2 output amplifier.
32	VSSD	Voltage Source Source Digital Negative Digital Power Supply
26	VDDD	Voltage Drain Drain Digital Positive Digital Power Supply

Detailed Block Diagram

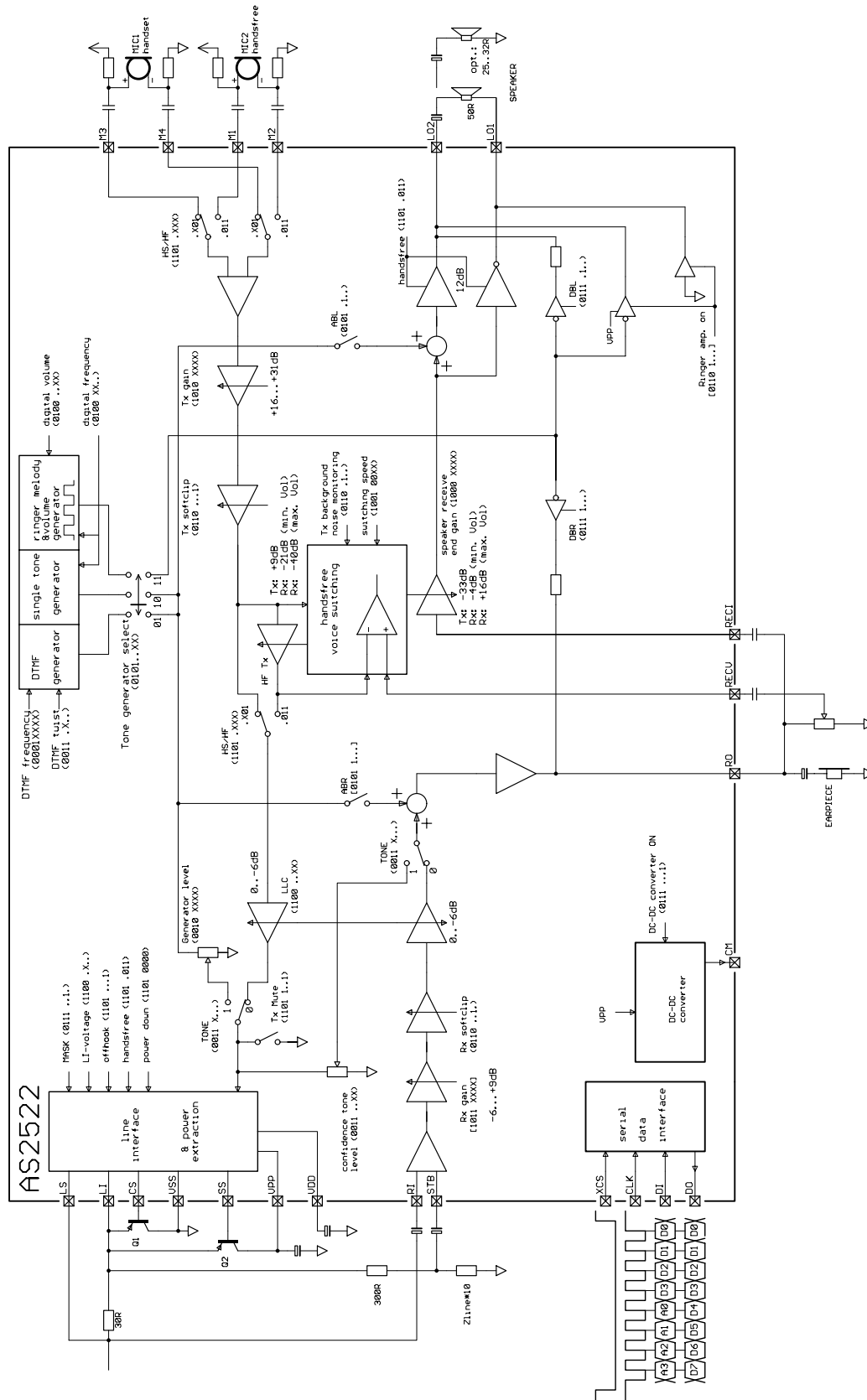

Functional Description

DC conditions

The normal operating mode is from 15mA to 100mA. An operating mode with reduced performance is from 5mA to 15mA. In the line hold range from 0mA to 5mA the device is in a power down mode.

The DC characteristic is determined by the voltage at LI-pin and a 30Ω resistor between LI- and LS-pin. It can be calculated by the following equation: $V_{LS} = V_{LI} + I_{Line} \cdot 30\Omega$. V_{LI} can be programmed to be 3.5V or 4.5V.

2/4 wire conversion

AS2522 has a built-in dual Wheatstone bridge with one common ground. This provides a maximum of independence of AC-impedance and side tone from each other. One can adapt side tone without changing the AC-impedance.

AC-impedance

The AC-impedance of AS2522 is set to t.m. 1000Ω. With the external capacitor at CI-pin it can be programmed complex. With an external resistor of approx. 1.5kΩ connected to the LS-pin it can be programmed to 600Ω.

Side Tone

A good side tone cancellation can be achieved by using the following equation:

$$Z_{BAL}/Z_{LINE} = 10$$

Transmit path

The gain of the M1/M2 → LS is set to +37dB. This gain can be changed by programming from +30dB to +45dB in 1dB steps (Register *Txgain*). The input is differential with an impedance of 10kΩ. The soft clip circuit limits the output voltage at LS to 2Vp. There is LLC for this path.

The gain of the M3/M4 → LS is set to +46dB.

This gain can be changed by programming from +39dB to +54dB in 1dB steps. The input is differential with an impedance of 10kΩ. The soft clip circuit limits the output voltage at LS to 2Vp. There is no LLC for this path.

Receive path

The gain of the LS → RO receive path is set to +1dB. This gain can be changed by programming from -6dB to +9dB in 1dB steps (Register *Rxgain*). The receive input is the differential signal of RI and STB. The soft clip circuit

limits the output voltage at RO to 1Vp. It prevents harsh distortion and acoustic shock. There is LLC for this path.

The gain of the LS → LO1/LO2 receive path is set to +29dB. This gain can be changed by programming from +22dB to -37dB in 1dB steps. The user can also change the gain via Register *VOL* (See section "Handsfree"). The receive input is the differential signal of RI and STB. The soft clip circuit limits the output voltage at LO1 of LO2 to 1Vp. It prevents harsh distortion and acoustic shock. There is optional LLC for this path.

Line Loss Compensation

The line loss compensation is programmable (Register *0x0C*). When it is activated, the transmit and receive gains for both I/O's are decreased by 6dB at line currents from 20mA to 50mA or from 45mA to 75mA.

Handsfree

The handsfree function allows voice communication without using the handset (full 2-way speaker phone). Two voice controlled attenuators prevent acoustic coupling between the loudspeaker and the microphone. The voice switching circuit has three states, namely idle, transmit or receive. In receive mode the attenuation of the receive path and the transmit path can be controlled by Register *VOL* between 0dB and -20dB. The following table shows how voice switching is controlled

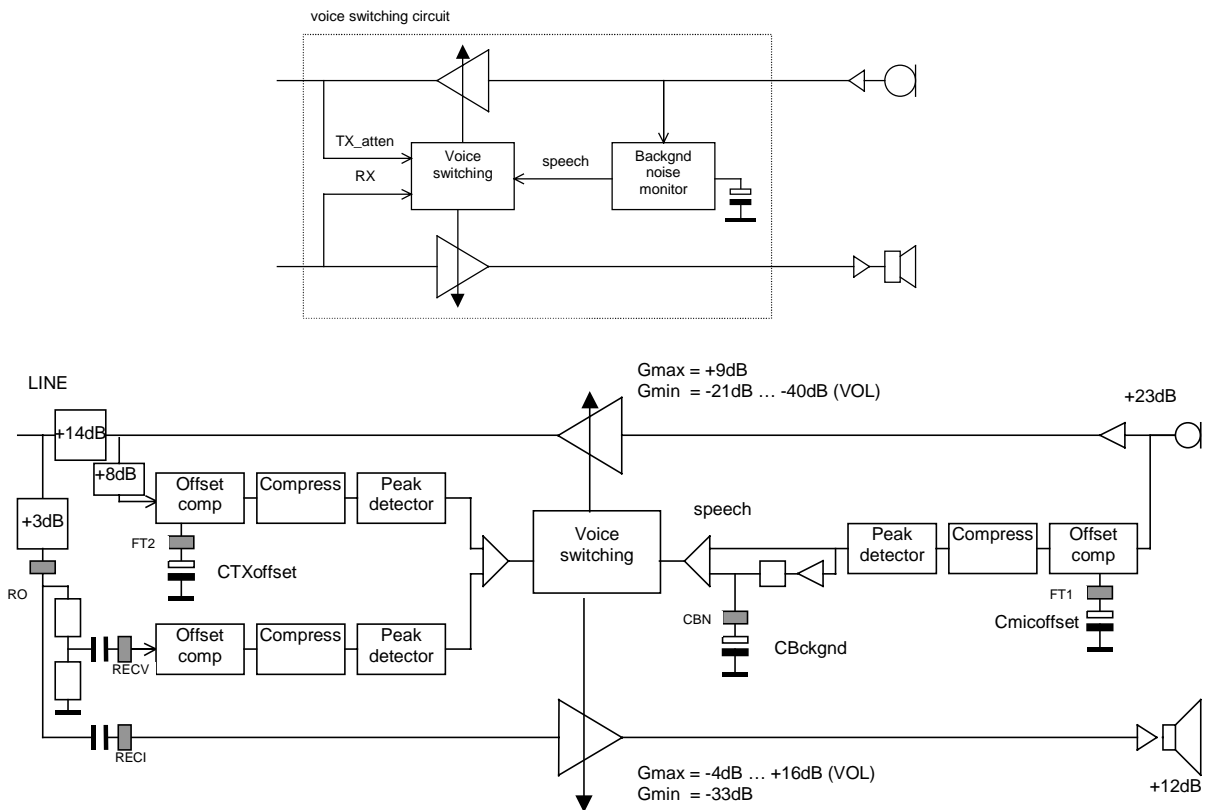

Speech	Mode	Rx-gain	Tx-gain	Remark
Rx > Tx_atten	X	Receive	0db to -20dB	adjustable with VOL-setting
Tx_atten > Rx	NO	Idle	-25	middle position
Tx_atten > Rx	YES	Transmit	-50dB	independent of VOL-setting

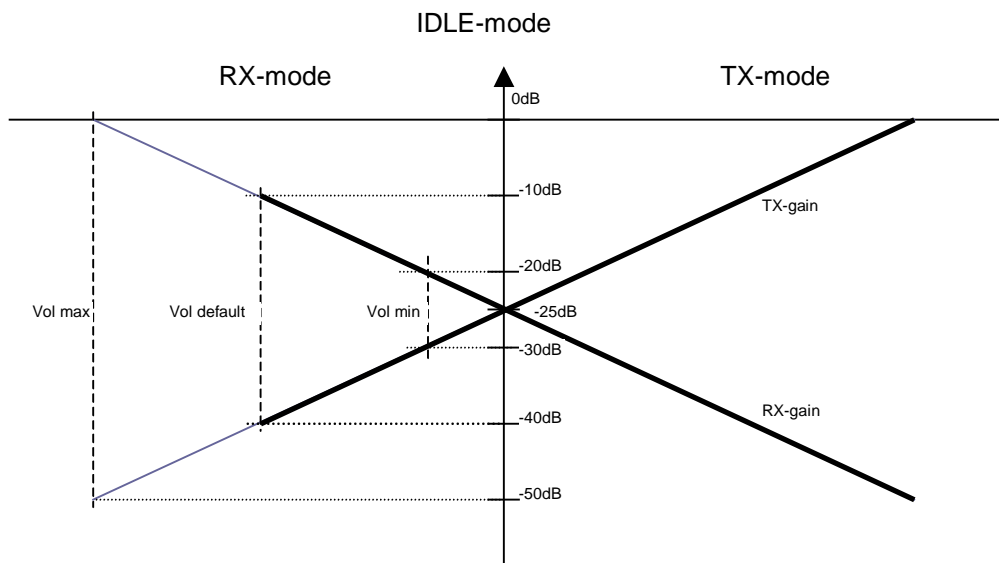

Serial Interface

Registers

The settings of the AS2522 are stored in 16 registers. Each register has 4 bit data width. Writing data into the AS2522 also causes the sending of the AS2522 status information on Pin D0. This information consists of the DC-current information (from the Line Loss Compensation circuit) and the status of the power-on reset circuit to test if AS2522 has already powered up.

D7	D6	D5	D4	D3	D2	D1	D0
LLC5	LLC4	LLC3	LLC2	LLC1	LLC0	xPOR	POR

Power on reset information in Statusbits D1 and D0

D1	D0	
0	0	
0	1	AS2522 is in POR state
1	0	AS2522 is active
1	1	

DC-current information in Statusbits D7 – D2

D[7:2]	LLC-bit LO	LLC-bit HI
000000	<20mA	<45mA
000001	20-26mA	45-51mA
000011	26-32mA	51-57mA
000111	32-38mA	57-63mA
001111	38-44mA	63-69mA
011111	44-50mA	69-75mA
111111	>50mA	>75mA

Timing

The data format for writing to a register has the following form:

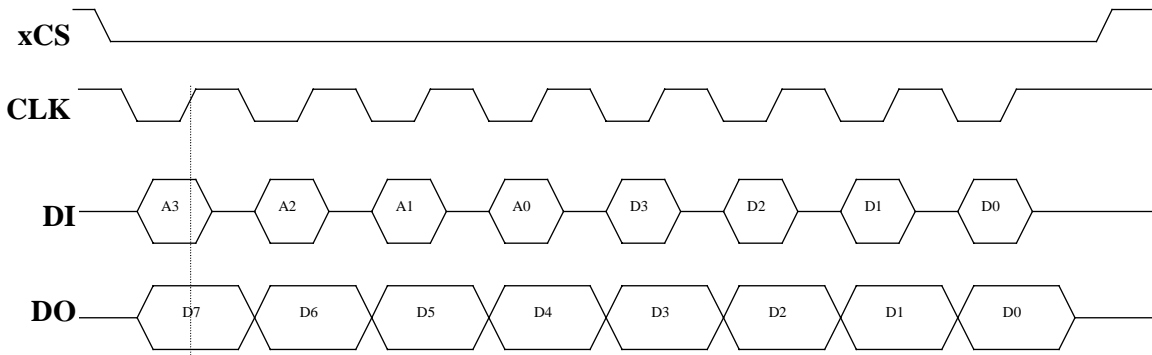

Note: The pins xCS,CLK,DI have internal pull-up resistors.

Parameter	Symbol	MIN	TYP	MAX
CLK Pulse width HIGH	t6	100ns		
CLK Pulse width LOW	t5	100ns		
xCS to first falling CLK-edge setup time	t1	50ns		
CLK to DOUT delay	t2		50ns	
DIN to CLK setup time	t3	50ns		
DIN to CLK hold time	t4	50ns		

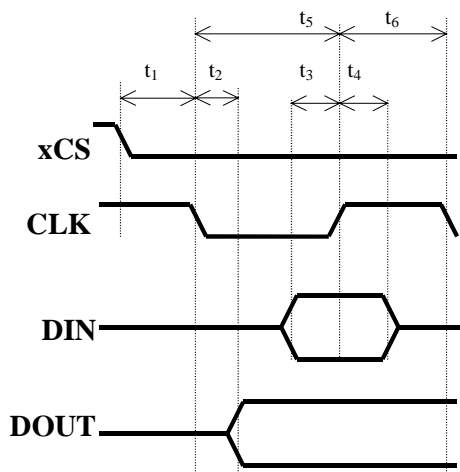

Serial interface Registers

The following table shows the content of the 16 control registers.

For a detailed description of the commands see Application note AN522.

Address	Data	Control registers AS2522A, AS2522B	Default value after reset																																																						
A A A A 3 2 1 0	D D D D 3 2 1 0																																																								
0 0 0 0	Nop	No operation. Write to this location to get AS2522-Status information without altering any other setting.	na																																																						
0 0 0 1	DTMFpair	Frequency select depending on Tone Generator mode DTMF-Generator mode: Single tone mode AS2522B ONLY AND FSK=1 (Addr 12):	0000																																																						
		<table border="1"> <thead> <tr> <th>HIGH Group</th> <th>LOW-Group</th> <th>Data</th> </tr> </thead> <tbody> <tr> <td>c1 c0 fHigh</td> <td>r1 r0 fLow</td> <td>f[3:0] Frequency</td> </tr> <tr> <td>0 0 1209Hz</td> <td>0 0 697Hz</td> <td>0000 0Hz</td> </tr> <tr> <td>0 1 1336Hz</td> <td>0 1 770Hz</td> <td>0001 800Hz (ring)</td> </tr> <tr> <td>1 0 1477Hz</td> <td>1 0 852Hz</td> <td>0010 1067Hz (ring)</td> </tr> <tr> <td>1 1 1633Hz</td> <td>1 1 941Hz</td> <td>0011 1333Hz (ring)</td> </tr> <tr> <td></td> <td></td> <td>0100 1300Hz (V.23)</td> </tr> <tr> <td></td> <td></td> <td>0101 2100Hz (V.23)</td> </tr> <tr> <td></td> <td></td> <td>0110 1200Hz (Bell 202)</td> </tr> <tr> <td></td> <td></td> <td>0111 2200Hz (Bell 202)</td> </tr> <tr> <td></td> <td></td> <td>1000 980Hz (V.21)</td> </tr> <tr> <td></td> <td></td> <td>1001 1180Hz (V.21)</td> </tr> <tr> <td></td> <td></td> <td>1010 1070Hz (Bell 103)</td> </tr> <tr> <td></td> <td></td> <td>1011 1270Hz (Bell 103)</td> </tr> <tr> <td></td> <td></td> <td>1100 1650Hz (V.21)</td> </tr> <tr> <td></td> <td></td> <td>1101 1850Hz (V.21)</td> </tr> <tr> <td></td> <td></td> <td>1110 2025Hz (Bell 103)</td> </tr> <tr> <td></td> <td></td> <td>1111 2225Hz (Bell 103)</td> </tr> </tbody> </table>	HIGH Group	LOW-Group	Data	c1 c0 fHigh	r1 r0 fLow	f[3:0] Frequency	0 0 1209Hz	0 0 697Hz	0000 0Hz	0 1 1336Hz	0 1 770Hz	0001 800Hz (ring)	1 0 1477Hz	1 0 852Hz	0010 1067Hz (ring)	1 1 1633Hz	1 1 941Hz	0011 1333Hz (ring)			0100 1300Hz (V.23)			0101 2100Hz (V.23)			0110 1200Hz (Bell 202)			0111 2200Hz (Bell 202)			1000 980Hz (V.21)			1001 1180Hz (V.21)			1010 1070Hz (Bell 103)			1011 1270Hz (Bell 103)			1100 1650Hz (V.21)			1101 1850Hz (V.21)			1110 2025Hz (Bell 103)			1111 2225Hz (Bell 103)	
HIGH Group	LOW-Group	Data																																																							
c1 c0 fHigh	r1 r0 fLow	f[3:0] Frequency																																																							
0 0 1209Hz	0 0 697Hz	0000 0Hz																																																							
0 1 1336Hz	0 1 770Hz	0001 800Hz (ring)																																																							
1 0 1477Hz	1 0 852Hz	0010 1067Hz (ring)																																																							
1 1 1633Hz	1 1 941Hz	0011 1333Hz (ring)																																																							
		0100 1300Hz (V.23)																																																							
		0101 2100Hz (V.23)																																																							
		0110 1200Hz (Bell 202)																																																							
		0111 2200Hz (Bell 202)																																																							
		1000 980Hz (V.21)																																																							
		1001 1180Hz (V.21)																																																							
		1010 1070Hz (Bell 103)																																																							
		1011 1270Hz (Bell 103)																																																							
		1100 1650Hz (V.21)																																																							
		1101 1850Hz (V.21)																																																							
		1110 2025Hz (Bell 103)																																																							
		1111 2225Hz (Bell 103)																																																							
0 0 1 0	DTMFLevel	DTMF-Level 13 steps, 1dB stepsize Data DTMF-level LOW GROUP at pin LS 0x0 -16dBm : : 0xC -4dBm	1100																																																						
0 0 1 1	x x x x	DTMF-settings Tone: DTMF-signal path 0...OFF, 1...ON preemph: DTMF-preempahsis 0...2.2dB, 1...3.2dB CT1 CT0: @RO @LO1/LO2 0 0 -36dB -15dB DTMF-confidence level 0 1 -30dB -9dB rel. to pin LS 1 0 -24dB -3dB 1 1 -18dB +3dB	0101																																																						
0 1 0 0	x x x x	Single Tone frequencies if FSK=0 (Addr. 12) and RING/Beep Volume [4] frequ1 frequ0 V1 V0: RING volume 0 0 800Hz 0 0 -17.5dB 0 1 1067Hz 0 1 -11.5dB 1 0 1333Hz 1 0 -5.5dB 1 1 1333Hz 1 1 0dB	0000																																																						
0 1 0 1	x x x x	Tone Generator mode, single tone path BURS: Analog tone at RO 0...OFF, 1...ON BURL: Analog tone at LO1/LO2 0...OFF, 1...ON M1 M0: Tone generator mode select 0 0 Tone generator OFF 0 1 DTMF generator mode 1 0 Single tone Analog mode 1 1 Single tone Digital mode (RING)	0000																																																						
0 1 1 0	x x x x	Softclip-settings, Noise monitoring RING: RING-path 0...OFF, 1...ON BNON: Noise monitor 0...OFF, 1...ON SOFTRX: Softclip RX 0...OFF, 1...ON SOFTTX: Softclip TX 0...OFF, 1...ON	0000																																																						
0 1 1 1	x x x x	DC/DC-Converter ON/OFF,Mask ldbr: Digital tone at RO 0...OFF, 1...ON ldbl: Digital tone at LO1/LO2 0...OFF, 1...ON MASK: Mask function 0...OFF, 1...ON DC/DC: DC/DC-converter 0...OFF, 1...ON	0000																																																						

Address		Data	Control registers AS2522A, AS2522B	Default value after reset					
A	A	A	A	D	D	D	D		
3	2	1	0	3	2	1	0		
1	0	0	0	16 gains				Handsfree receive endgain	0111
				Data RXgain TXgain 0x0 -20dB -30dB Min. receive volume : : 0xF 0dB -50dB Max. receive volume					
1	0	0	1	x	x	x	x	Handsfree switching characteristic	1000
				off1 off0: BGN-offset 0 0 120mV 0 1 180mV 1 0 240mV 1 1 300mV Hfs1 HFs0: Speed of voice switching 0 0 max speed 0 1 1 0 1 1 min speed					
1	0	1	0	16 gains				Transmit gain [16], 16 steps, 1dB stepsize	0111
				Data HS-mode HF-mode 0x0 30dB 39dB : : 0xF 45dB 54dB					
1	0	1	1	16 gains				Receive gain [16], 16 steps, 1dB stepsize	0111
				Data HS-mode HF-mode 0x0 -6dB 22dB : : 0xF +9dB 37dB					
1	1	0	0	x	x	x	x	FSK-mode, LLC[2], LI-Voltage	0111
				AS2522B: FSK: Frequency select in single tone mode AS2522B ONLY FSK: 0 Single Tone frequencies are read from Addr. 4: frequ1, frequ0 1 Single Tone frequencies are read from Addr. 1: f4,f3,f2,f1 AS2522A FSK: For factory test only ! LIV: Voltage at pin LI 0...3.5V, 1...4.5V LLC1 LLC0: Line loss compensation setting 0 0 20mA-50mA 0 1 NO Line loss compensation 1 0 45-75mA 1 1 NO Line loss compensation					
1	1	0	1	x	x	x	x	Mute, Lh, Hf, Hook Switch	0000
				Mute: Mute transmit 0...OFF, 1...ON His Hf Lh 0 x x On Hook 1 0 0 Off Hook, Handset mode 1 1 0 Off Hook, Handfree mode 1 1 1 Off Hook, Loudhearing mode					
1	1	1	0	x	x	x	x	Krat5,Test3,Test2,Test1: For factory test only !	0000
				Krat5 Test3 Test2 Test1					
1	1	1	1	x	x	x	x	Reset to defaults	na

Electrical characteristics

Electrical characteristics are measured with the Test Circuit application. Typical mean values will not be tested.

Absolute maximum ratings

Positive Supply Voltage	-0.3V <= VDD <= 7V
Input Current	+/- 25mA
Input Voltage (LS)	-0.3V <= Vin <= 12V
Input Voltage (LI, CS)	-0.3V <= Vin <= 8V
Input Voltage (STB, RI)	-2V <= Vin <= VDD+0.3V
Digital Input Voltage	-0.3V <= Vin <= VDD+0.3V
Electrostatic Discharge (HBM 1.5kΩ-100pF)	+/- 1000V
Storage Temperature	-65°C to +125°C

Recommended operating conditions

Supply Voltage (generated internally)	3V <= VDD <= 5V
Operating Temperature	-25°C to +70°C

DC characteristics

I_{Line}=15mA w/o operation of any additional external circuitry, unless other specified

Symbol	Parameter	Conditions	Min	Type	Max	Units	Test
I _{DDS}	Operating Current	Speech Mode		3	6	mA	Y
I _{DDH}	Operating Current	Handsfree Mode		7	10	mA	Y
V _{LI}	Line Voltage LIVolt=0	15mA<=I _{LINE} <=100mA	3.2	3.5	3.8	V	Y
	Line Voltage LIVolt=1		4.2	4.5	4.8	V	Y
I _{OL}	Output Current, Sink CS,SS	VOL=0.4V		1		mA	N

Transmit characteristicsI_{Line}=15mA f=800Hz, default settings unless other specified

Symbol	Parameter	Conditions	Min	Type	Max	Units	Test
AM1/2TX	Transmit Gain M1/M2 → LS	Z _{AC(syn)} =1000Ω	35	+36.5	38	dB	Y
AM3/4TX	Transmit Gain M3/M4 → LS	Z _{AC(syn)} =1000Ω	43	+45.0	47	dB	Y
ΔATX	Variation with frequency	f = 500Hz ... 3.4kHz		±0.8		dB	N
AVRM12	Control range M1/M2 → LS	16 steps		-7/+8		dBr	N
AVRM34	Control range M2/M4 → LS	16 steps		-7/+8		dBr	N
THD	Distortion	V _{LS} =0.25V _{RMS}			2	%	Y
VAGC1	Soft Clip Level M1/M2 → LS at LS			2		VP	N
VAGC2	Soft Clip Level M3/M4 → LS at LS			2		VP	N
ASCO	Soft Clip Overdrive M1/M2 - M3/M4			20		dB	N
t _{attack}	Attack time			70		us/6dB	N
t _{decay}	Decay time			100		ms/6dB	N
Z _{IN-M1/2}	Input Impedance M1/M2			10		kΩ	N
Z _{IN-M3/4}	Input Impedance M3/M4			10		kΩ	N
V _{INmax}	Input Voltage Range M1/2 - M3/4	differential		±1		V _p	N
V _{NO}	Noise Output Voltage LS	T _{AMP} =25°C Handset mode Gain = 36.5dB			-72	dBmp	Y
AMUTE	Mute Attenuation	Mute activated	60			dB	Y

Receive characteristicsI_{Line}=15mA f=800Hz, default settings unless other specified

Symbol	Parameter	Conditions	Min	Type	Max	Units	Test
ARO	Receive Gain LS → RO	Z _{AC(syn)} =1000Ω Vol default	-2	-0.5	1	dB	Y
ALO12	Receive Gain LS → LO1/LO2	Z _{AC(syn)} =1000Ω Vol maximum	+28	+29.0	+31	dB	Y
ΔARX	Variation with frequency	f=500Hz to 3.4kHz		±0.8		dB	N
AVRRO	Control range LS → RO	16 steps		-7/+8		dBr	N
AVRLS	Control range LS → LS1/LS2	16 steps		-7/+8		dBr	N
THDLS	Distortion LS1/LS2	V _{LS} =0.25VRMS			5	%	Y
THDRO	Distortion RO	V _{LS} =0.25VRMS			2	%	Y
VUFC	Unwanted Freq. Cmp.	f = 200 ... 20kHz			-60	dBm	Y
VAGCRO	Soft Clip Level RO			1		VP	N
VAGCLS	Soft Clip Level LS1/2			2		VP	N
ASCLS	Soft Clip Overdrive LS1/2			10		dB	N
t _{attack}	Attack time			70		us/6dB	N
t _{decay}	Decay time			100		ms/6dB	N
VNO	Noise Output Voltage RO	T _{AMP} =25°C Gain = 3dB			-72	dBmp	Y
ZIN-RI V _{INmax}	Input Imp. RI Input Voltage Range RI			8 ±2		kΩ Vp	N
ZIN-STB V _{INmax}	Input Imp. STB Input Volt. Range STB			80 ±2		kΩ Vp	N
ST	Side tone	V _{RI} ≤0.25VRMS	26			dB	Y
RL ΔZ _{AC} /°C	Return Loss Temp. Variation	Z _{AC(syn)} =1000Ω	18	0.5		dB Ω/°C	Y

DTMF characteristics

ILine=15mA w/o operation of any additional external circuitry, unless other specified, default settings

Symbol	Parameter	Conditions	Min	Type	Max	Units	Test
VMFlow	Tone level low group at LS	Default	-7	-6	-5	dBm	Y
MFrang	DTMF level range low group at LS	13 steps Prg. in Service mode		-18/-6		dBm	N
Δ VL-H	Preemphasis L-H	Preemphasis=1	2.7	3.2	3.7	dB	Y
UFC	Unwanted frequency components	300 Hz - 4.3kHz			-40	dBm	Y
		4.3kHz - 7kHz			-46	dBm	Y
		7kHz - 10kHz			-52	dBm	Y
		10kHz - 14kHz			-58	dBm	Y
		14kHz - 28.5kHz			-70	dBm	Y
		28.5kHz - 40kHz			-80	dBm	Y
Δ f	Frequency deviation				1.2	%	Y
V _{CT-H}	Comfort tone handset	Rel to LS			-36	dBr	N
		programmable in service mode			-30	dBr	N
					-24	dBr	N
					-18	dBr	N
V _{CT-L}	Comfort tone Loudspeaker	Rel to LS			-15	dBr	N
		programmable in service mode			-9	dBr	N
					-3	dBr	N
					+3	dBr	N

Ringer

Symbol	Parameter	Conditions	Min	Type	Max	Units	Test
F0	Frequency 0			0		Hz	N
F1	Frequency 1		770	800	830	Hz	Y
F2	Frequency 2		1025	1067	1110	Hz	Y
F3	Frequency 3		1280	1333	1385	Hz	Y
F4	Frequency 4			1300		Hz	N
F5	Frequency 5			2100		Hz	N
F6	Frequency 6			1200		Hz	N
F7	Frequency 7			2200		Hz	N
F8	Frequency 8			980		Hz	N
F9	Frequency 9			1180		Hz	N
F10	Frequency 10			1070		Hz	N
F11	Frequency 11			1270		Hz	N
F12	Frequency 12			1650		Hz	N
F13	Frequency 13			1850		Hz	N
F14	Frequency 14			2025		Hz	N
F15	Frequency 15			2225		Hz	N

Miscellaneous

Symbol	Parameter	Conditions	Min	Type	Max	Units	Test
VPARO	Pacifier level at RO	RL = 150 Ohm		30		mVpp	N
VPALS	Pacifier level at LS1/2	RL = 50 Ohm		100		mVpp	N

Test circuit

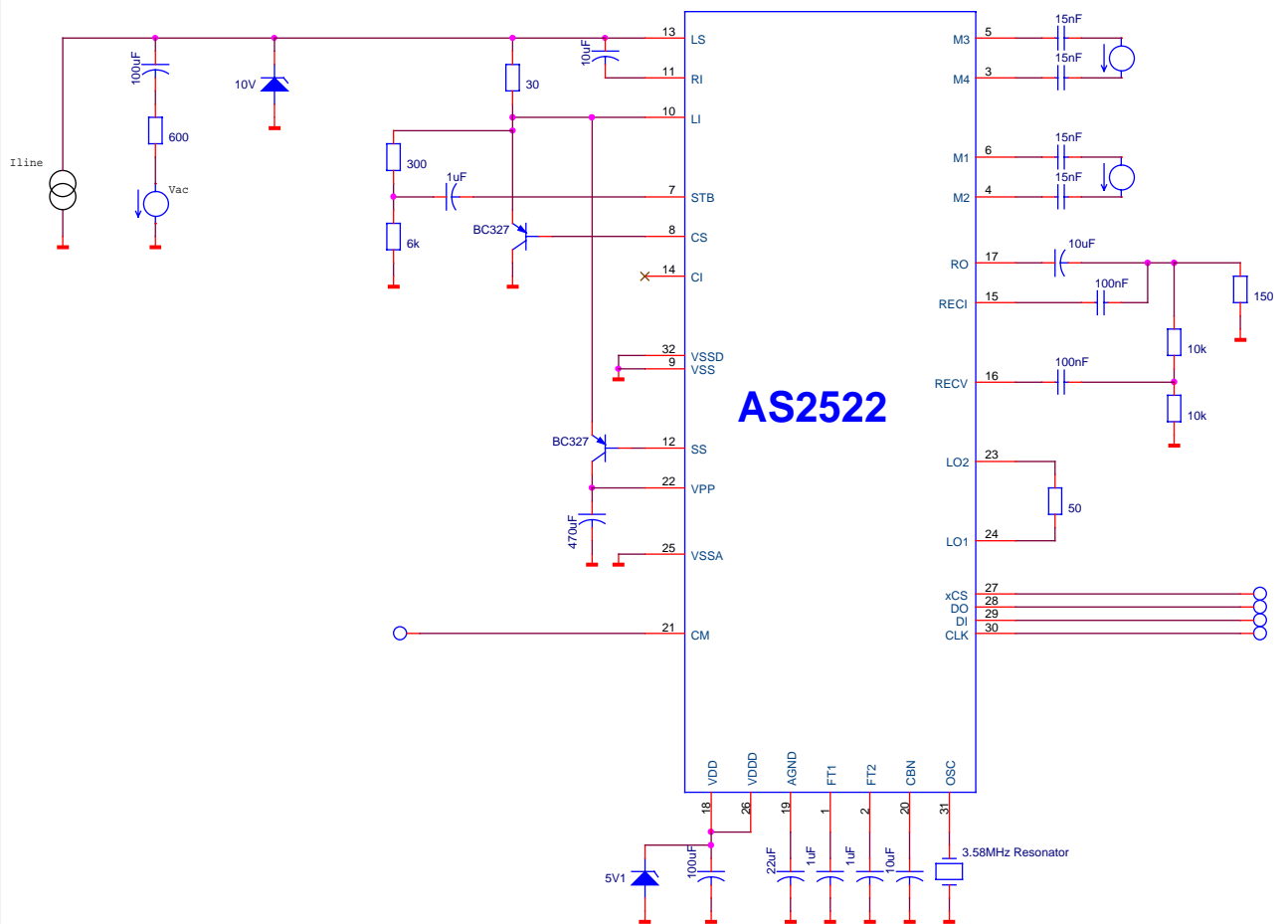

Typical application

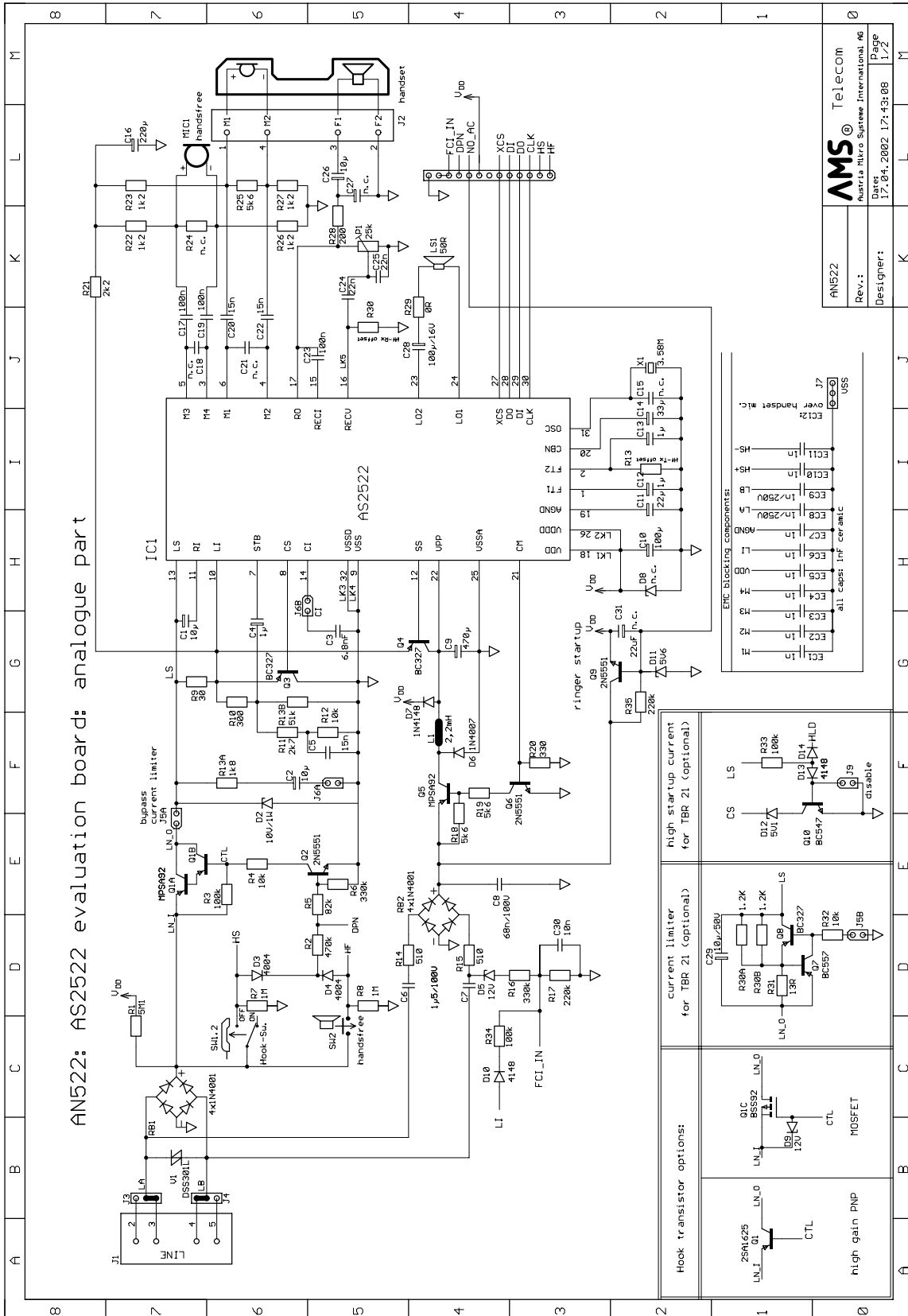

AMS	TeleCOM
Austria Mikro Systeme International AG	
Rev.:	17.04.2002 17:43:08
Designer:	Page 1/2

Bonding Diagram

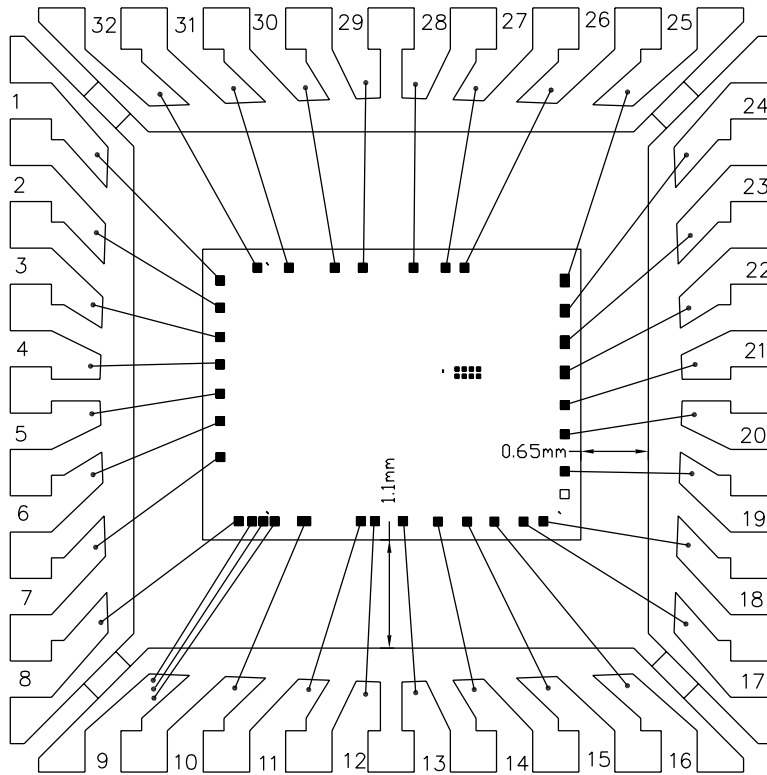

32 Lead 7x7mm TQFP dimensions

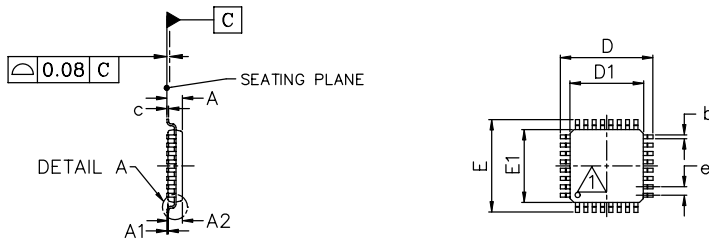

SYMBOL	MILLIMETER			INCH		
	MIN	NOM	MAX	MIN	NOM	MAX
A	1.00	1.10	1.20	.039	.043	.047
A1	0.05	0.10	0.15	.002	.004	.006
A2	0.95	1.00	1.05	.037	.039	.041
D	8.80	9.00	9.20	.346	.354	.362
D1	6.90	7.00	7.10	.272	.276	.280
E	8.80	9.00	9.20	.346	.354	.362
E1	6.90	7.00	7.10	.272	.276	.280
L	0.45	0.60	0.75	.018	.024	.030
e	0.80 BSC.			.0315 BSC.		
b	0.30	0.37	0.45	.012	.015	.018
c	0.13	0.16	0.20	.005	.006	.008

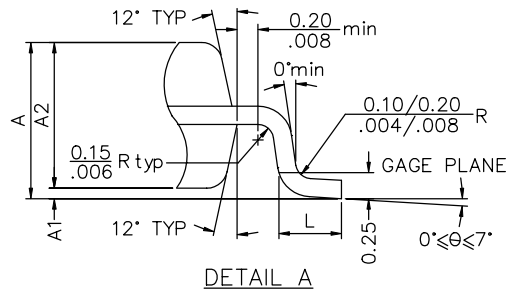

Packaging

32-pin plastic TQFP (suffix Q)

For exact mechanical package dimensions please see austriamicrosystems_{AG} packaging information.

Pin-out, Marking

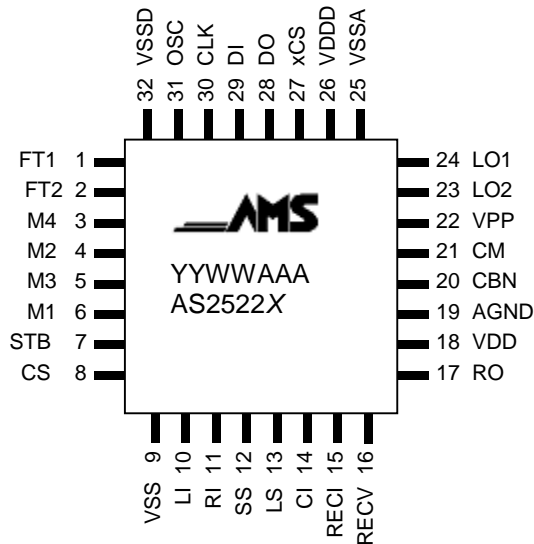

YY	year of production
WW	calendar week of production
AAA	austriamicrosystems _{AG} assembly ID
X	revision

Ordering Information

Number	Package	Description
AS2522B Q	TQFP	plastic thin quad flat package – 32 leads (suffix T)
AS2522B F	DOF	Dice-on-Foil

Devices sold by austriamicrosystems AG are covered by the warranty and patent identification provisions appearing in its Term of Sale. austriamicrosystems AG makes no warranty, express, statutory, implied, or by description regarding the information set forth herein or regarding the freedom of the described devices from patent infringement. austriamicrosystems AG reserves the right to change specifications and prices at any time and without notice. Therefore, prior to designing this product into a system, it is necessary to check with austriamicrosystems AG for current information. This product is intended for use in normal commercial applications. Applications requiring extended temperature range, unusual environmental requirements, or high reliability applications, such as military, medical life-support or life-sustaining equipment are specifically not recommended without additional processing by austriamicrosystems AG for each application.

Copyright

Copyright © 1997-2002, austriamicrosystems AG, Schloss Premstaetten, 8141 Unterpremstaetten, Austria-Europe. Trademarks Registered ®. All rights reserved. The material herein may not be reproduced, adapted, merged, translated, stored, or used without the prior written consent of the copyright owner.

The information furnished here by austriamicrosystems AG is believed to be correct and accurate. However, austriamicrosystems AG shall not be liable to recipient or any third party for any damages, including but not limited to personal injury, property damage, loss of profits, loss of use, interruption of business or indirect, special, incidental or consequential damages, of any kind, in connection with or arising out of the furnishing, performance or use of the technical data herein. No obligation or liability to recipient or any third party shall arise or flow out of austriamicrosystems AG rendering of technical or other services.

Contact

Headquarters

austriamicrosystems AG
Communications Business Unit
A 8141 Schloss Premstätten, Austria
T. +43 (0) 3136 500 0
F. +43 (0) 3136 525 01
www.austriamicrosystems.com

Sales Offices

Germany

austriamicrosystems Germany GmbH
Tegernseer Landstrasse 85
D-81539 München, Germany
Phone: +49/89/693643-0
Fax: +49/89/693643-66

France

austriamicrosystems France S.a.r.l.
124, Avenue de Paris
F-94300 Vincennes, France
Phone: +33/1/43 74 00 90
Fax: +33/1/43 74 20 98

Italy

austriamicrosystems Italy S.r.l.
Via Leone Tolstoj, 64
I-20146 Milano, Italy
Phone: +39/0242/36713
Fax: +39/0242/290889

Switzerland

austriamicrosystems Switzerland AG
Rietstrasse 4
CH-8640 Rapperswil, Switzerland
Phone: +41/55/220 9000
Fax: +41/55/220 9001

USA (west)

austriamicrosystems USA, Inc.
Suite 116, 4030 Moorpark Ave,
San Jose, CA 95117, USA
Phone: +1/408/345 1790
Fax: +1/408/345 1795

USA (east)

austriamicrosystems USA, Inc.
Suite 400, 8601 Six Forks Road
Raleigh, NC 27615, USA
Phone: +1/919/676 5292
Fax: +1/919/676 5305

United Kingdom

austriamicrosystems UK, Ltd.
Coliseum Business Centre, Watchmoor Park
Camberley, Surrey, GU15 3YL, UK
Phone: +44/1276/23 3 99
Fax: +44/1276/29 3 53

Japan

austriamicrosystems AG
Shin Yokohama Daini, Center Bldg. 10F
3-19-5, Shin Yokohama
Kohoku-ku, Yokohama 222-0033, Japan
Phone: +81/45/474 0962
Fax: +81/45/472 9845

Distributors & Representatives

austriamicrosystems AG is represented by distributors in the following countries. Please contact your nearest regional sales office for the distributor address:

Spain, Israel, Korea, Hong-Kong, Taiwan, Malaysia, Singapore, India, Brazil

Application Support

Please contact your local sales office or your distributor.

Компания «Life Electronics» занимается поставками электронных компонентов импортного и отечественного производства от производителей и со складов крупных дистрибьюторов Европы, Америки и Азии.

С конца 2013 года компания активно расширяет линейку поставок компонентов по направлению коаксиальный кабель, кварцевые генераторы и конденсаторы (керамические, пленочные, электролитические), за счёт заключения дистрибьюторских договоров

Мы предлагаем:

- Конкурентоспособные цены и скидки постоянным клиентам.
- Специальные условия для постоянных клиентов.
- Подбор аналогов.
- Поставку компонентов в любых объемах, удовлетворяющих вашим потребностям.
- Приемлемые сроки поставки, возможна ускоренная поставка.
- Доставку товара в любую точку России и стран СНГ.
- Комплексную поставку.
- Работу по проектам и поставку образцов.
- Формирование склада под заказчика.
- Сертификаты соответствия на поставляемую продукцию (по желанию клиента).
- Тестирование поставляемой продукции.
- Поставку компонентов, требующих военную и космическую приемку.
- Входной контроль качества.
- Наличие сертификата ISO.

В составе нашей компании организован Конструкторский отдел, призванный помогать разработчикам, и инженерам.

Конструкторский отдел помогает осуществить:

- Регистрацию проекта у производителя компонентов.
- Техническую поддержку проекта.
- Защиту от снятия компонента с производства.
- Оценку стоимости проекта по компонентам.
- Изготовление тестовой платы монтаж и пусконаладочные работы.



Тел: +7 (812) 336 43 04 (многоканальный)

Email: org@lifeelectronics.ru