



## AC/DC-sensitive Differential Current Sensors (DI-Sensors)

- Closed loop sensors with magnetic probe for highest accuracy and reliability
- Differential current range typically 30 to 300 mA
- Full load current to 50 A
- Single +5 V voltage supply
- Voltage output for direct connection at A/D – converters
- Automatic demagnetization of the sensor core for offset decrease
- Self-monitoring and test functions
- Measuring accuracy 1.5%
- Smallest temperature drift, highest long-term stability
- Metal screen against external fields
- Frequency range DC to 10 kHz
- Variants with passing through opening and with integrated primary conductors, with or without test winding
- Active sensors with integrated electronics
- Economical construction



### Applications

Control devices with AC/DC-sensitive differential current sensors are used primarily in transformerless solar inverters. An important safety function of these

devices is the monitoring of the leakage current of the entire system from photovoltaic - modules and inverter against earth. A defective system can become dangerous for people or release fires. Before it comes so far, the inverter must disconnect from the grid. The leakage current contains DC and AC components. Therefore an AC/DC-sensitive monitoring unit is necessary. Their heart is the VAC differential current sensor, whose output voltage is evaluated by the control system of the solar inverter.

Generally protection devices with AC/DC-sensitive differential current sensors can be used everywhere, where flat or pulsating DC can develop, whose amount is permanently greater than zero. Further examples are power supplies producing high DC voltages or uninterruptable power supplies.

### Variants of the VAC Sensors

It is both a type available with an opening for the primary conductor, as well as types with built-in primary conductors for PCB mounting. There are versions with two or four conductors for single and three phase systems.

The additional functions demagnetization, error signaling and internal test power are accessible through defined levels at the inputs / outputs  $V_{out}$  and  $V_{ref}$ .



### Functional description, technical data, available Types

Item no.	T60404-N4646-			
	... X950	... X960	... X975	...X976
<b>Style</b>				
<b>Dimensional diagram no.</b>	1	2	3	4
<b>Primary conductor style</b>	opening	via PCB. Two conductors A= 6,2 mm <sup>2</sup> for operating current	via PCB. Two conductors A= 6,2 mm <sup>2</sup> for operating current, one conductor for external test current	via PCB. Four conductors A= 4,9 mm <sup>2</sup> for operating current, one conductor for external test current
<b>Properties</b>				
<b>Supply voltage</b>	5 V			
<b>Supply current</b>	typ. 17 mA			
<b>Maximum primary current</b>	50 A			
<b>Nominal differential current</b>	300 mA			
<b>Output voltage</b>	reference voltage $\pm (0,74 \times \text{differential current} / 300 \text{ mA})$			
<b>Measuring range</b>	$\pm 850 \text{ mA}$			
<b>Output voltage range</b>	0,5 V ... 4,5 V			
<b>Reference voltage</b>	2,5 V reference voltage, internally generated or $V_{ref}=1.4$ to 3.5 from external source			
<b>Frequency range</b>	0 ... 10 kHz, limited by internal low pass filter. An additional external filter with e.g. 5 kHz roll off frequency is recommended.			
<b>Measuring error</b> at $T_{amb} = 25^{\circ}\text{C}$	< 1,5 % of nominal differential current			
<b>Temperature drift</b> -40 ... +85°C	< 0,1 mV/°C			
<b>Response time</b> (up to 90% of nominal differential current)	< 35 $\mu\text{s}$			
<b>Isolation strength</b> acc. to EN50178 (primary- and test current conductor vs. signal and supply voltage connections)  - system voltage - working voltage	to be maintained by a proper insulation of the primary onductor		600 V 1.000 V	
<b>Additional functions</b>				
<b>Error condition</b>  - indicated by - criteria	- output voltage < 0,5 V - break or short circuit of the magnetic probe, supply voltage smaller 4 Volts, during the demagnetization cycle.			
<b>Demagnetization</b> of the Sensor core  - triggered by - duration of cycle	- feeding the supply voltage <i>or</i> transition from <1 V to 2,5 V (normal voltage) at the reference voltage input, i.e. after test current cycle - 120 ms			
<b>Internal DC test current</b> for self test  - triggered by - output signal at test current	- setting reference voltage to 0 V (<1 V) - $U_{DC} = +0,25 \text{ V}$ at $V_{ref} = 0 \text{ V}$ . A possibly appearing primary current is superimposed			



## Maßbilder

Maßbild Nr. 1

Typen  
**T60404-N4646-X950**

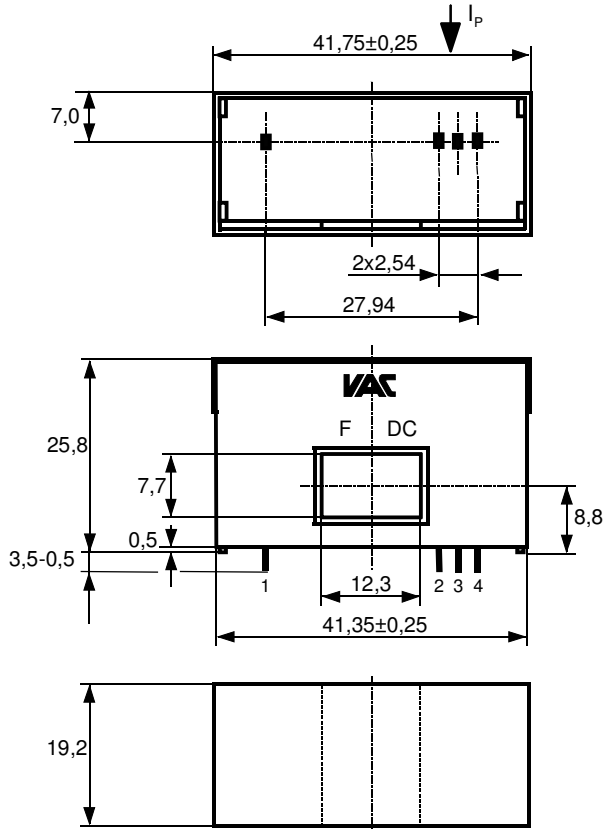

Toleranz der Stiftabstände  
 $\pm 0,2$  mm  
(Tolerances grid distance)

Marking:  
UL Mark  
Excerpt from  
Item no.  
F DC, in which  
F = Factory  
DC = Date Code

Connections:  
1 ... 4:  $0,7 \times 0,6$  mm

Pin Assignments  
1  $V_c +5 V$   
2 GND  
3  $V_{ref}$  In/Out  
4  $V_{out}$

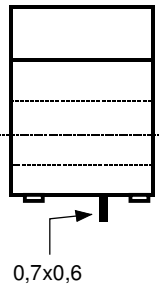



Maßbild Nr. 2

Typ  
T60404-N4646-X960

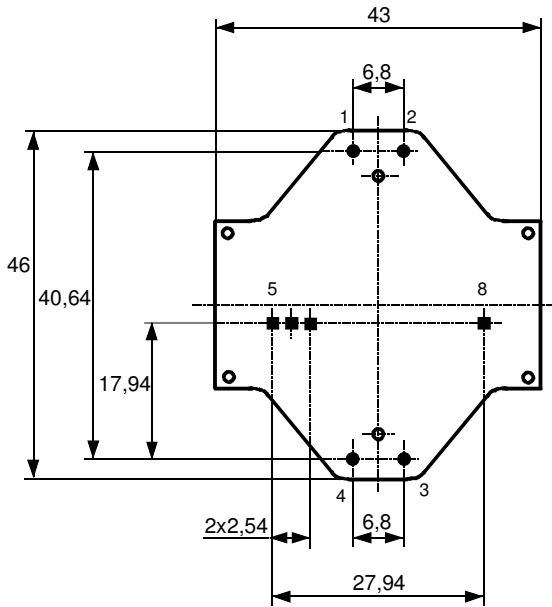

Toleranz der Stiftabstände  $\pm 0,2$ mm  
(Tolerances grid distance)

Marking:  
UL Mark  
Excerpt from  
Item no.  
F DC, in which  
F = Factory  
DC = Date Code

Connections:  
1 ... 4:  $\varnothing 2,8$  mm  
5 ... 8: 0,7 x 0,6 mm

Pin Assignments  
1 ... 4: primary current  
5  $V_{out}$   
6  $V_{ref}$   
7 GND  
8  $V_c +5 V$



Maßbild Nr. 3

Typ  
T60404-N4646-X975

Toleranz der Stiftabstände  $\pm 0,3\text{mm}$   
(Tolerances grid distance)

Prüfmaß  
(test dimension)

Beschriftung  
(marking)

DC = Date Code  
F = Factory



Marking:

UL Mark  
Excerpt from  
Item no.  
F DC, in which  
F = Factory  
DC = Date Code

Connections:

1 ... 4:  $\varnothing 2,8\text{ mm}$   
5 ... 8:  $0,7 \times 0,6\text{ mm}$   
9, 10:  $\varnothing 0,8\text{ mm}$

Pin Assignments

1 ... 4: primary current  
9, 10: test current  
5  $V_{out}$   
6  $V_{ref}$   
7 GND  
8  $V_c +5\text{ V}$



Maßbild Nr. 4

Typ  
T60404-N4646-X976

Toleranz der Stiftabstände  
Pin 1...6 = ±0,2mm  
Pin 7...14 = ±0,3mm  
(Tolerances grid distance)

DC =Date Code  
F =Factory

○ Prüfmaß  
(test dimension)



Beschriftung  
(marking)



Marking:  
UL Mark  
Excerpt from  
Item no.  
F DC, in which  
F = Factory  
DC = Date Code

Connections:  
1 ... 4: 0,6 x 0,7 mm  
5 ... 6: Ø 0,8 mm  
7 ... 14: Ø 2,5 mm

Pin Assignments  
1 V<sub>c</sub> +5 V  
2 GND  
3 V<sub>ref</sub>  
4 V<sub>out</sub>  
5, 6: test current  
7 ... 14: primary current



**VACUUMSCHMELZE GMBH & CO. KG**

GRÜNER WEG 37  
D-63450 HANAU  
PHONE +49 6181 38 0  
FACSIMILE +49 6181 38 2645  
INFO@VACUUMSCHMELZE.COM  
WWW.VACUUMSCHMELZE.COM

**VAC SALES USA LLC**

2935 DOLPHIN DRIVE  
SUITE 102  
42701 ELIZABETHTOWN KY / USA  
PHONE +1 270 769-1333  
FACSIMILE +1 270 765 3118  
INFO-USA@VACUUMSCHMELZE.COM

**VACUUMSCHMELZE SALES OFFICE SINGAPORE**

61 KAKI BUKIT AVENUE 1 #04-16  
SHUN LI INDUSTRIAL PARK  
SINGAPORE 417943  
TELEFON +65 6391 2600  
FAX +65 6391 2601  
VACSINGAPORE@VACUUMSCHMELZE.COM

## **VACUUMSCHMELZE GmbH & Co. KG**

### **ADVANCED MATERIALS – THE KEY TO PROGRESS**

Published by VACUUMSCHMELZE GmbH & Co. KG, Hanau  
© VACUUMSCHMELZE 2012. All rights reserved.

As far as patents or other rights of third parties are concerned, liability is only assumed for products per se, not for applications, processes and circuits implemented within these products. The information describes the type of product and shall not be considered as assured characteristics. Terms of delivery and rights to change design reserved.

Компания «Life Electronics» занимается поставками электронных компонентов импортного и отечественного производства от производителей и со складов крупных дистрибьюторов Европы, Америки и Азии.

С конца 2013 года компания активно расширяет линейку поставок компонентов по направлению коаксиальный кабель, кварцевые генераторы и конденсаторы (керамические, пленочные, электролитические), за счёт заключения дистрибьюторских договоров

Мы предлагаем:

- Конкурентоспособные цены и скидки постоянным клиентам.
- Специальные условия для постоянных клиентов.
- Подбор аналогов.
- Поставку компонентов в любых объемах, удовлетворяющих вашим потребностям.
- Приемлемые сроки поставки, возможна ускоренная поставка.
- Доставку товара в любую точку России и стран СНГ.
- Комплексную поставку.
- Работу по проектам и поставку образцов.
- Формирование склада под заказчика.
- Сертификаты соответствия на поставляемую продукцию (по желанию клиента).
- Тестирование поставляемой продукции.
- Поставку компонентов, требующих военную и космическую приемку.
- Входной контроль качества.
- Наличие сертификата ISO.

В составе нашей компании организован Конструкторский отдел, призванный помогать разработчикам, и инженерам.

Конструкторский отдел помогает осуществить:

- Регистрацию проекта у производителя компонентов.
- Техническую поддержку проекта.
- Защиту от снятия компонента с производства.
- Оценку стоимости проекта по компонентам.
- Изготовление тестовой платы монтаж и пусконаладочные работы.



Тел: +7 (812) 336 43 04 (многоканальный)

Email: [org@lifeelectronics.ru](mailto:org@lifeelectronics.ru)