

TTG-Series

ROCKER SWITCHES

The TTG-Series Mid-Sized Tippette snap-in rocker switches consist of two single pole illuminated or non-illuminated switches in a common base. Each pole can have the same or different switch function. These switches are AC rated up to 20 amps and are also suitable for low-voltage DC applications, in a wide range of markets.

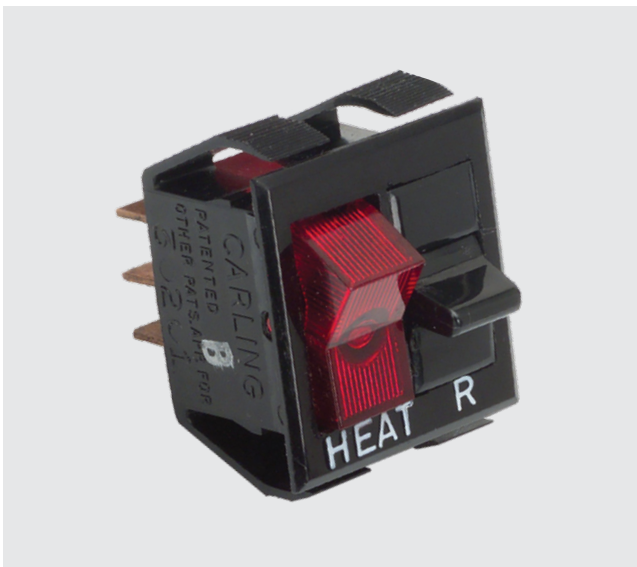

Product Highlights:

- ♦ Independent or Dependent Illumination
- ♦ Ratings up to 20 Amps
- ♦ Diamond or Long Line Lens Options
- ♦ Self-Cleaning Wiping Style Contacts

Typical Applications:

- ♦ Appliance
- ♦ HVAC
- ♦ Food Service
- ♦ Transportation



Dielectric Strength

UL/CSA:
1000V - live to dead metal parts

Electrical Life

50,000 cycles - maintained
25,000 cycles - momentary

Mechanical Life

100,000 cycles

Operating Temperature

32°F to 185°F (0°C to 85°C)

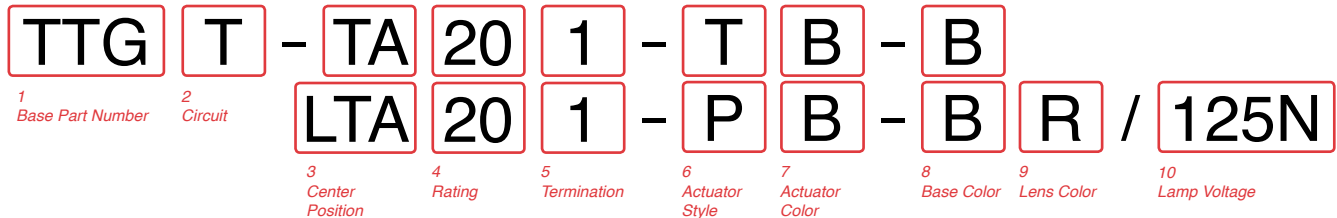

1 BASE PART NUMBER: SERIES	
TTG	Two Single Pole switches in one base
2 CIRCUIT ¹	
See Circuit Designation Chart	
3 BASIC SWITCH NUMBER	
TA	On-None-Off
TB	On-None-On
TC	On-Off-On
LTA	On-None-Off, Lighted
4 RATING	
10	5A 250VAC, 10A 125VAC, 1/2HP 125-250VAC
11	5A 250VAC, 10A 125VAC, 5A 125VAC L
20	10A 250VAC, 15A 125VAC, 3/4HP 125-250VAC
21	10A 250VAC, 15A 125VAC
22	10A 250VAC, 15A 125VAC, 20A 125-250VAC H, 3/4HP 125-250VAC
5 TERMINATION / FUNCTION	
	Solder Lug .250 Tab QC .187 Tab QC Wire Leads
On-None-Off	0 1 3 5
(On)-None-Off	A B D F
On-None-(Off)	L M R T
On-None-On	0 1 3 5
On-None-(On)	A B D F
On-Off-On	0 1 3 5

6 ACTUATOR STYLE		PS	Short Paddle
P		Paddle	Rocker
7 ACTUATOR COLOR		lighted³	
unlighted²		A	Amber
B		C	Clear
W		G	Green
		LU	Blue
		R	Red
8 BASE COLOR ²		B	Black
		W	White
9 LENS COLOR ⁴		A	Amber
		C	Clear
		G	Green
		LU	Blue
		R	Red
		W	White
10 LAMP VOLTAGE		neon	
incandescent		6V	6 volt
		12V	12 volt
		18V	18 volt
		24V	24 volt
		28V	28 volt
		125N	125 volt neon
		250N	250 volt neon

Notes:
Imprinting is available. Consult factory.
Panel Cut-Out Recommendations: For sheet metal panels, switch must enter panel in same direction as the punch. (Burr on bottom.) Test cut hole in actual material.
1 TG available with circuits A, B, C, D, E, F, L, T, U, G, H, I, J, M, N, P, Q, R, T, U, V, Y, Z.
2 Custom colors are available. Consult factory.
3 Specify lens color for LTA with rocker only.
4 Specify lens color for LTA with paddle actuators only.
() Indicates momentary function.

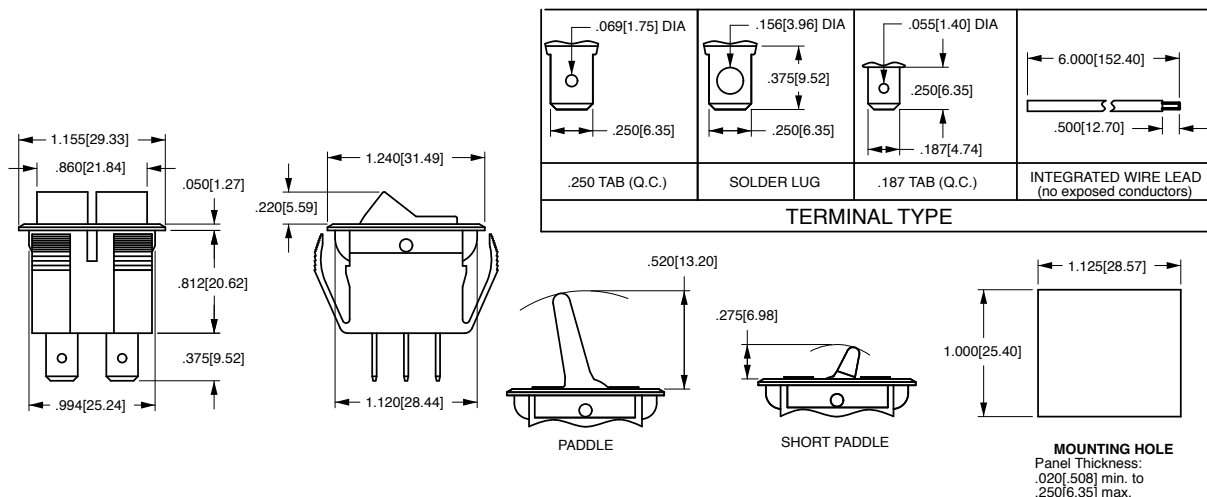

*Manufacturer reserves the right to change product specification without prior notice.

Circuit Designation Chart:

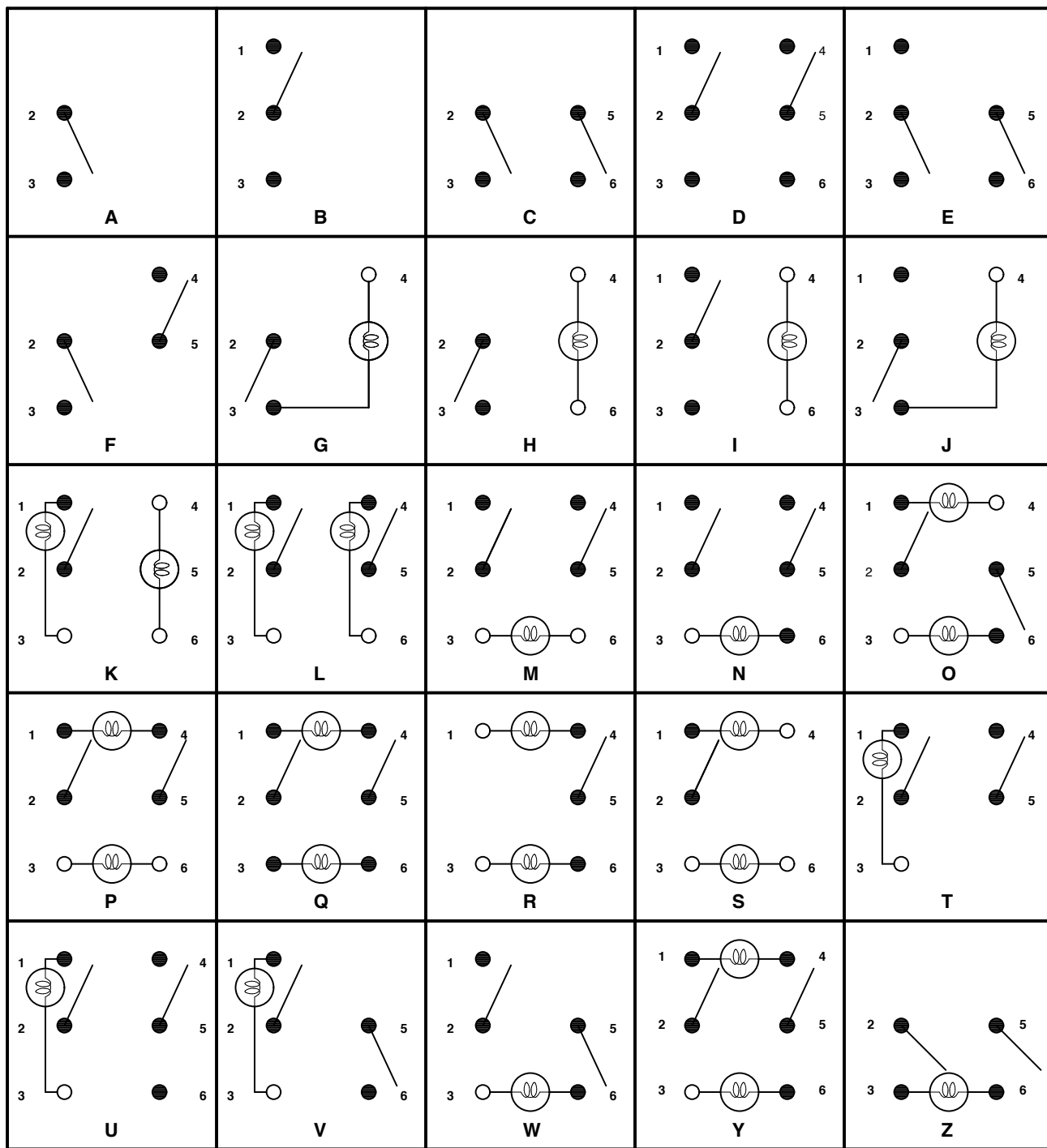

● CONTACT TERMINAL
Will make contact with switching lever

● CONTACT TERMINAL AND SWITCH LEVER

○ ISOLATED TERMINAL
Does not make contact with switching lever

○ BULB

Authorized Sales Representatives

Click on the group name on the map below to find your local representative or visit www.carlingtech.com/findarep.

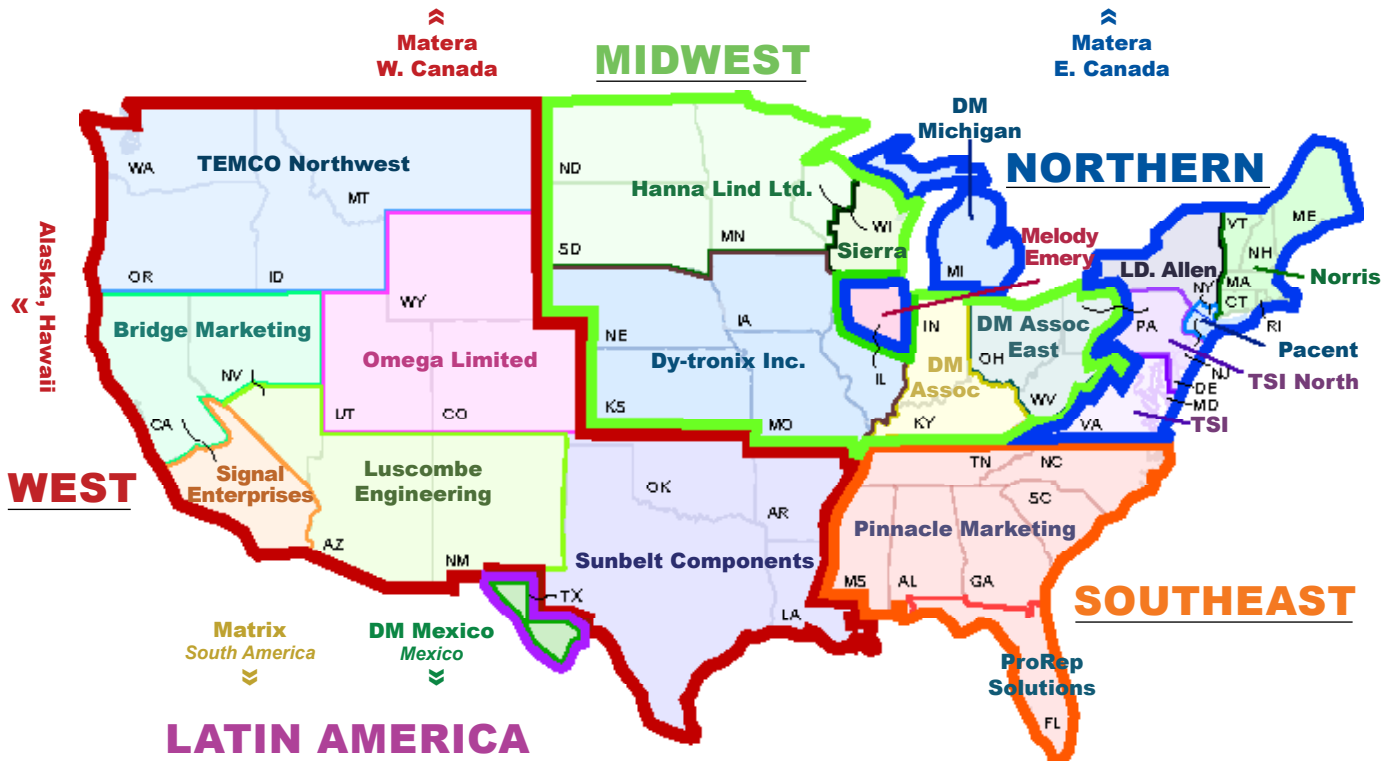

Americas



Europe
Middle East
Africa



Asia-Pacific
Oceania

About Carling

Founded in 1920, Carling Technologies is a leading manufacturer of electrical and electronic switches and assemblies, circuit breakers, electronic controls, power distribution units, and multiplexed power distribution systems. With four ISO registered manufacturing facilities and technical sales offices worldwide, Carling Technologies Sales, Service and Engineering teams do much more than manufacture electrical components, they engineer powerful solutions! To learn more about Carling please visit www.carlingtech.com/company-profile.

To view all of Carling's environmental, quality, health & safety certifications please visit www.carlingtech.com/environmental-certifications

Worldwide Headquarters

Carling Technologies, Inc.
60 Johnson Avenue, Plainville, CT 06062
Phone: 860.793.9281 **Fax:** 860.793.9231
Email: sales@carlingtech.com

Northern Region Sales Office: nrsm@carlingtech.com
Southeast Region Sales Office: sersm@carlingtech.com
Midwest Region Sales Office: mrsm@carlingtech.com
West Region Sales Office: wrsm@carlingtech.com
Latin America Sales Office: larsm@carlingtech.com

Asia-Pacific Headquarters

Carling Technologies, Asia-Pacific Ltd.,
Kowloon, Hong Kong
Phone: Int + 852-2737-2277 **Fax:** Int + 852-2736-9332
Email: sales@carlingtech.com.hk

Shenzhen, China: shenzhen@carlingtech.com
Shanghai, China: shanghai@carlingtech.com
Pune, India: india@carlingtech.com
Kaohsiung, Taiwan: taiwan@carlingtech.com
Yokohama, Japan: japan@carlingtech.com

Europe | Middle East | Africa Headquarters

Carling Technologies LTD
4 Airport Business Park, Exeter Airport,
Clyst Honiton, Exeter, Devon, EX5 2UL, UK
Phone: Int + 44 1392.364422 **Fax:** Int + 44 1392.364477
Email: ltd.sales@carlingtech.com

Germany: gmbh@carlingtech.com
France: sas@carlingtech.com



Carling Technologies®

Innovative Designs. Powerful Solutions.

Компания «Life Electronics» занимается поставками электронных компонентов импортного и отечественного производства от производителей и со складов крупных дистрибьюторов Европы, Америки и Азии.

С конца 2013 года компания активно расширяет линейку поставок компонентов по направлению коаксиальный кабель, кварцевые генераторы и конденсаторы (керамические, пленочные, электролитические), за счёт заключения дистрибьюторских договоров

Мы предлагаем:

- Конкуренеспособные цены и скидки постоянным клиентам.
- Специальные условия для постоянных клиентов.
- Подбор аналогов.
- Поставку компонентов в любых объемах, удовлетворяющих вашим потребностям.
- Приемлемые сроки поставки, возможна ускоренная поставка.
- Доставку товара в любую точку России и стран СНГ.
- Комплексную поставку.
- Работу по проектам и поставку образцов.
- Формирование склада под заказчика.
- Сертификаты соответствия на поставляемую продукцию (по желанию клиента).
- Тестирование поставляемой продукции.
- Поставку компонентов, требующих военную и космическую приемку.
- Входной контроль качества.
- Наличие сертификата ISO.

В составе нашей компании организован Конструкторский отдел, призванный помогать разработчикам, и инженерам.

Конструкторский отдел помогает осуществить:

- Регистрацию проекта у производителя компонентов.
- Техническую поддержку проекта.
- Защиту от снятия компонента с производства.
- Оценку стоимости проекта по компонентам.
- Изготовление тестовой платы монтаж и пусконаладочные работы.



Тел: +7 (812) 336 43 04 (многоканальный)
Email: org@lifeelectronics.ru