

LOC	DIST	REVISIONS			
DF	AO	REV	DATE	BY	APPV
B		REVISED PER ECO-13-002047	05FEB2013	MGM	CT

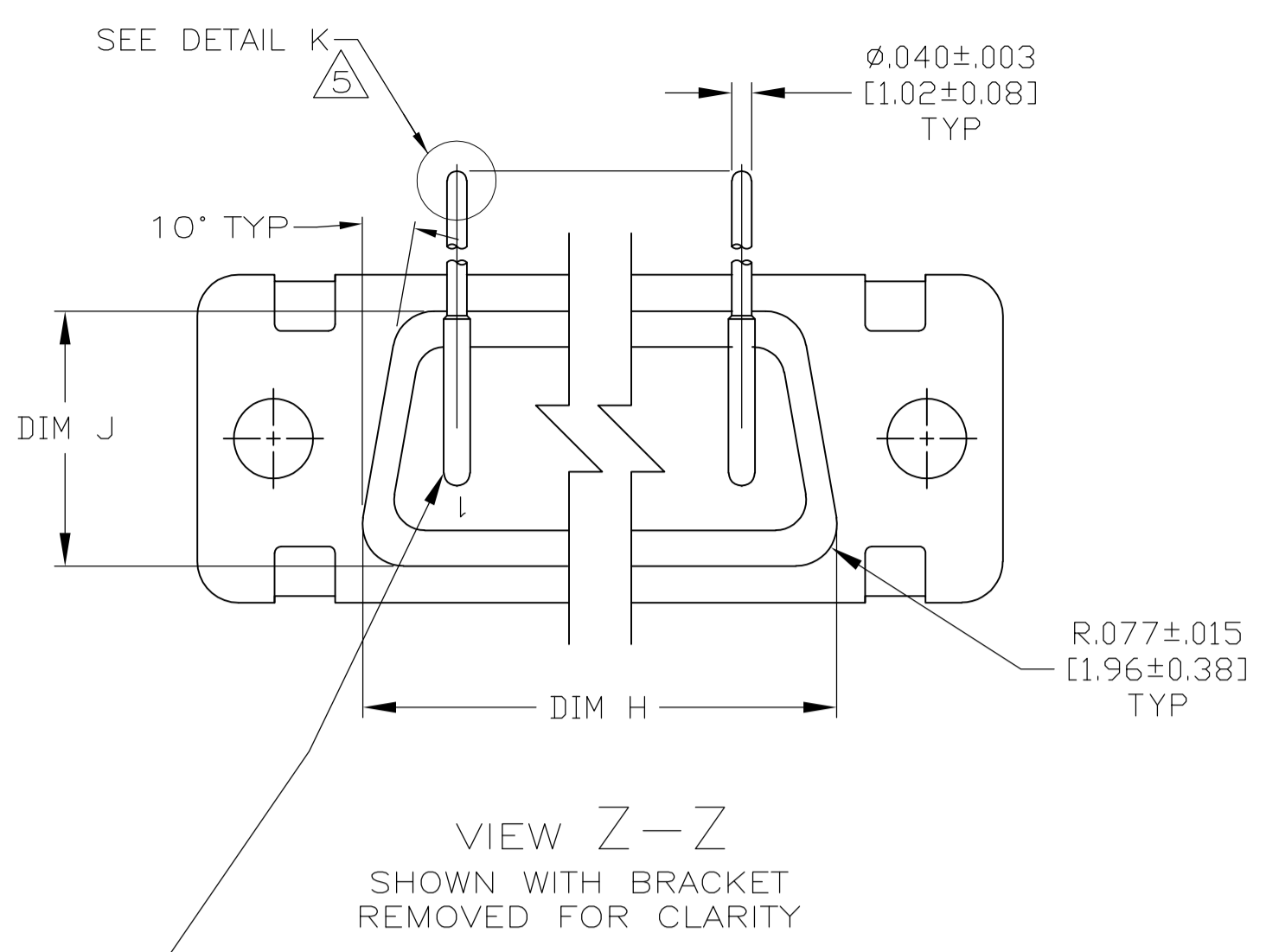
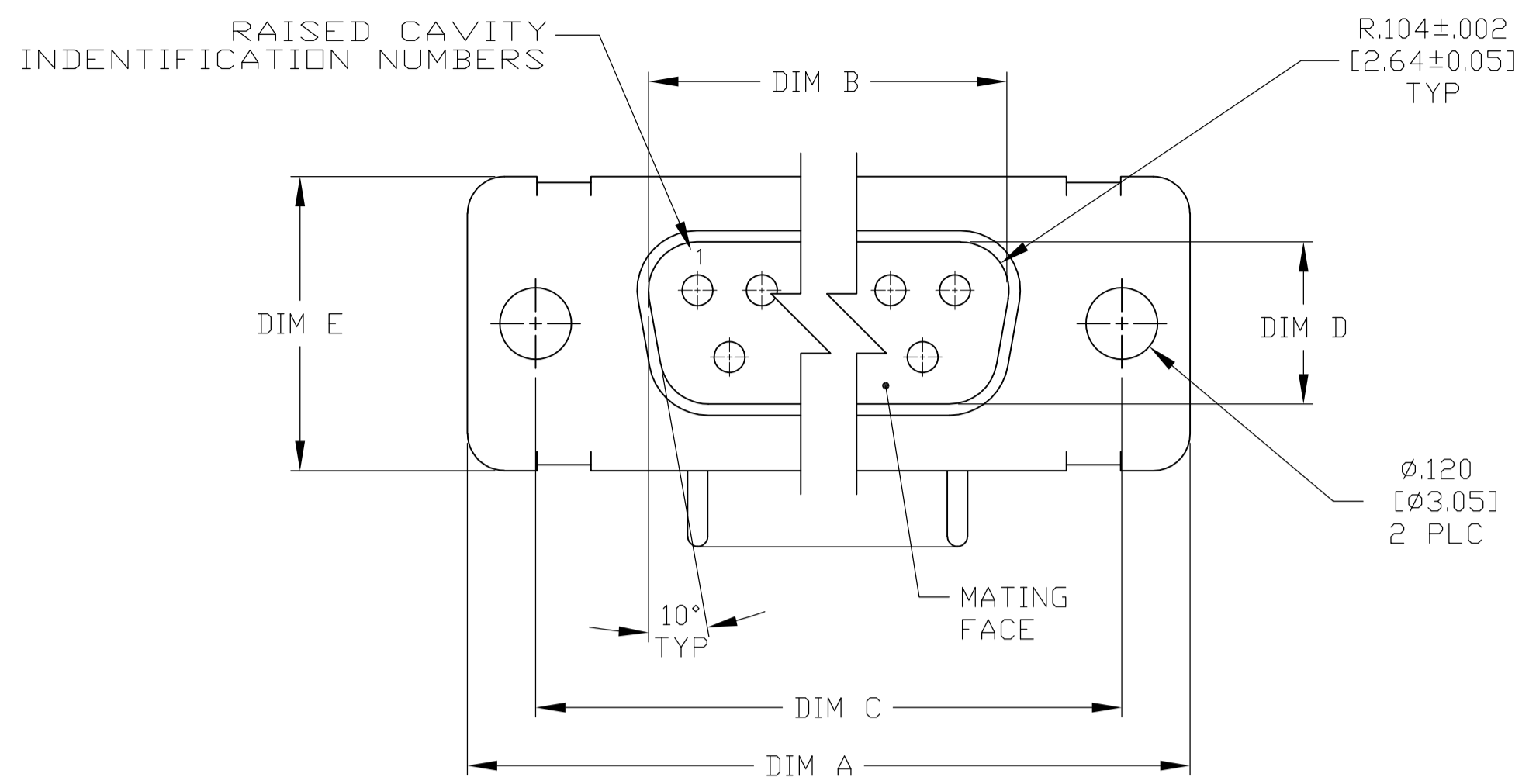

VIEW Z-Z
SHOWN WITH BRACKET REMOVED FOR CLARITY

CONTACT (QTY = NO. OF POSN)
MATL: BRASS PER ASTM-B-16, OR BERYLLIUM COPPER PER ASTM-B-194
FINISH: GOLD PER ASTM-B-488, TYPE II, GRADE C, CLASS 1.27 IN CONTACT MATING AREA, .000010 [0.0003] MIN THK GOLD PER ASTM-B-488 OVER .000050 [0.0013] MIN THK NICKEL PER SAE-AMS-QQ-N-290 ON CONTACT BODY

1. SEE SHEET 2 FOR RECOMMENDED P.C. BOARD LAYOUT. TRUE POSITION TOLERANCE FOR P.C. BOARD LAYOUT IS .010 [0.25] AT MAX MATERIAL CONDITION. SUGGESTED BOARD THICKNESS IS .062 [1.57]
2. THE CONNECTORS DESCRIBED IN THIS DOCUMENT MEET THE REQUIREMENTS OF MIL-C-24308 AND MATE WITH ANY RECEPTACLE CONNECTOR WITH SAME INSERT ARRANGEMENT.
3. MARKED WITH .047 [1.19]-.062 [1.57] HIGH CHARACTERS. FAR SIDE REFERS TO THE WIDE SIDE OF THE KEYSTONE. NEAR SIDE REFERS TO THE NARROW SIDE OF THE KEYSTONE. IF THE SHELL IS TOO SMALL FOR THE ENTIRE MARKING, MARKING SHALL BE SPLIT AS FOLLOWS:
 - A. "M24308" ON FRONT SHELL, FAR SIDE.
 - B. SLASH SHEET AND DASH NUMBER ON REAR SHELL, FAR SIDE.
 - C. "MFG'S" (NAME, BRAND OR LOGO) AND DATE CODE ON FRONT SHELL, NEAR SIDE.
 - D. MFG'S PART NUMBER ON REAR SHELL, NEAR SIDE.
4. REQUIREMENT FOR FULL PIN DIAMETER EXTENSION:
 - .159 [4.04] MIN, SHELL SIZES 1 AND 2.
 - .150 [3.81] MIN, SHELL SIZES 3 AND 4.
5. SOLDER DIPPED PER J-STD-001 WITH Sn63 SOLDER PER J-STD-006 IN THE ENTIRE AREA OF DIMENSION SHOWN. (1757845-6 THRU -10 ONLY.)
6. MEETS SOLDERABILITY PER MIL-STD-202 METHOD 208.

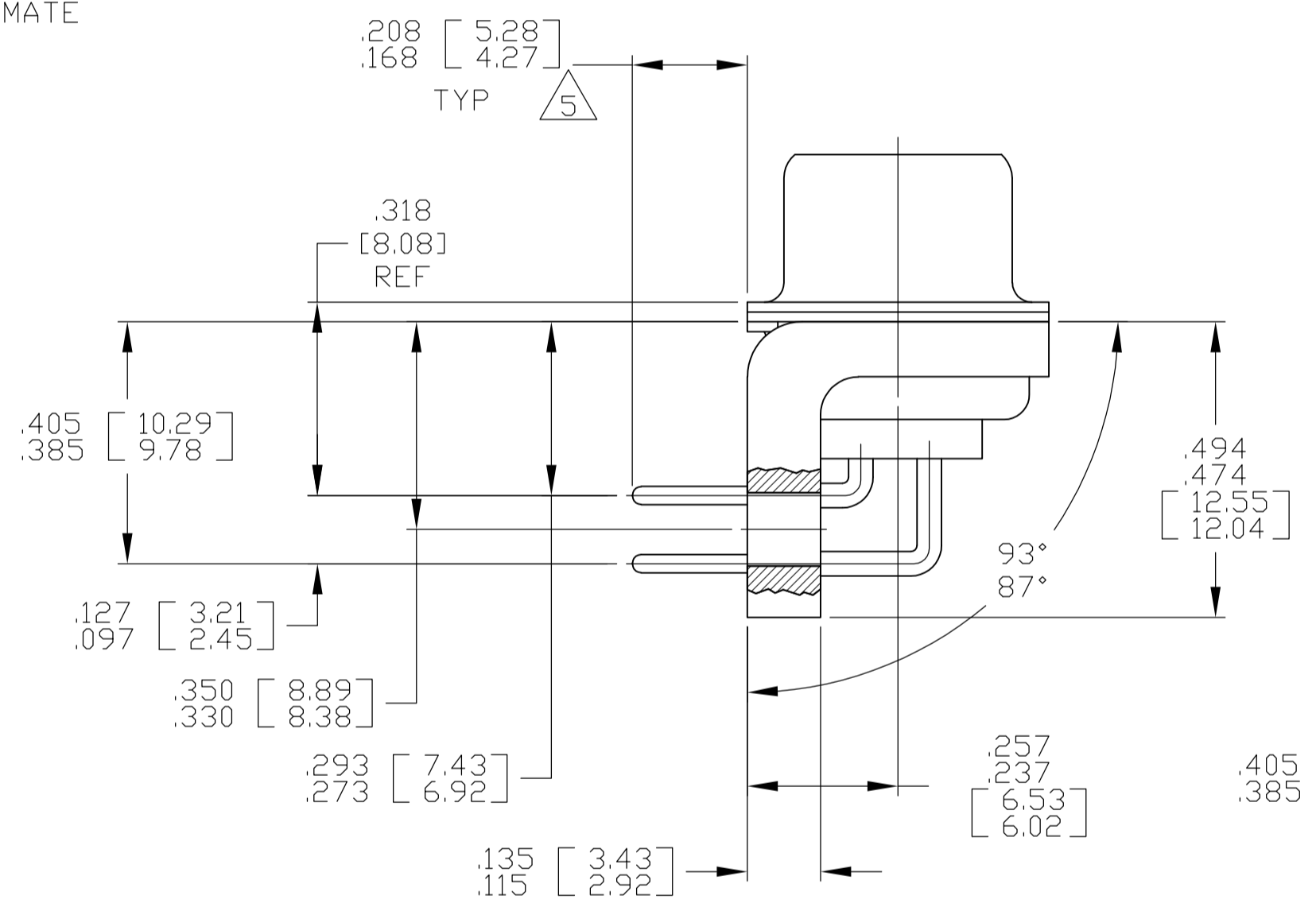
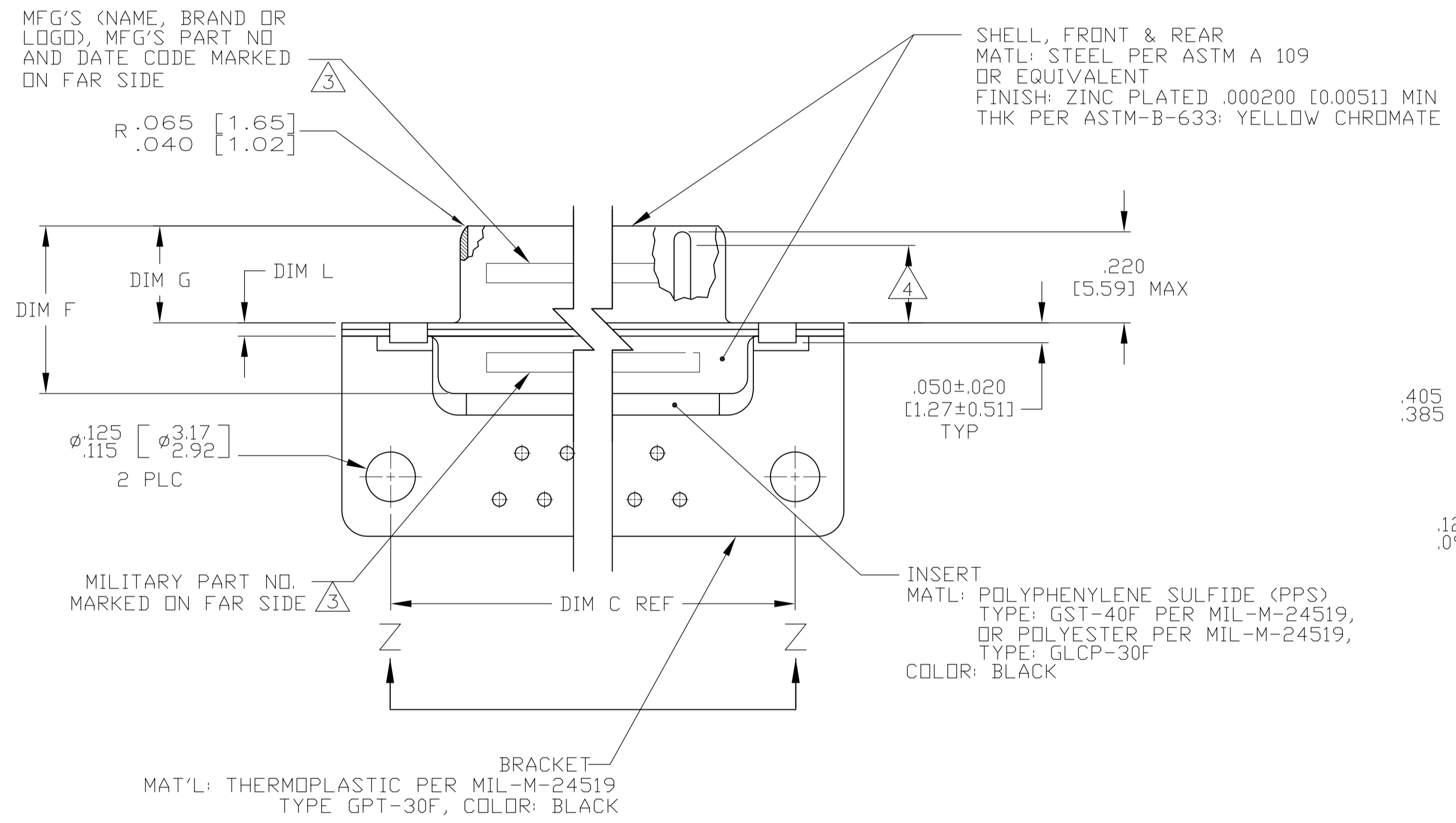

SHELL SIZES 1 THRU 4 CONTACT CONFIGURATION

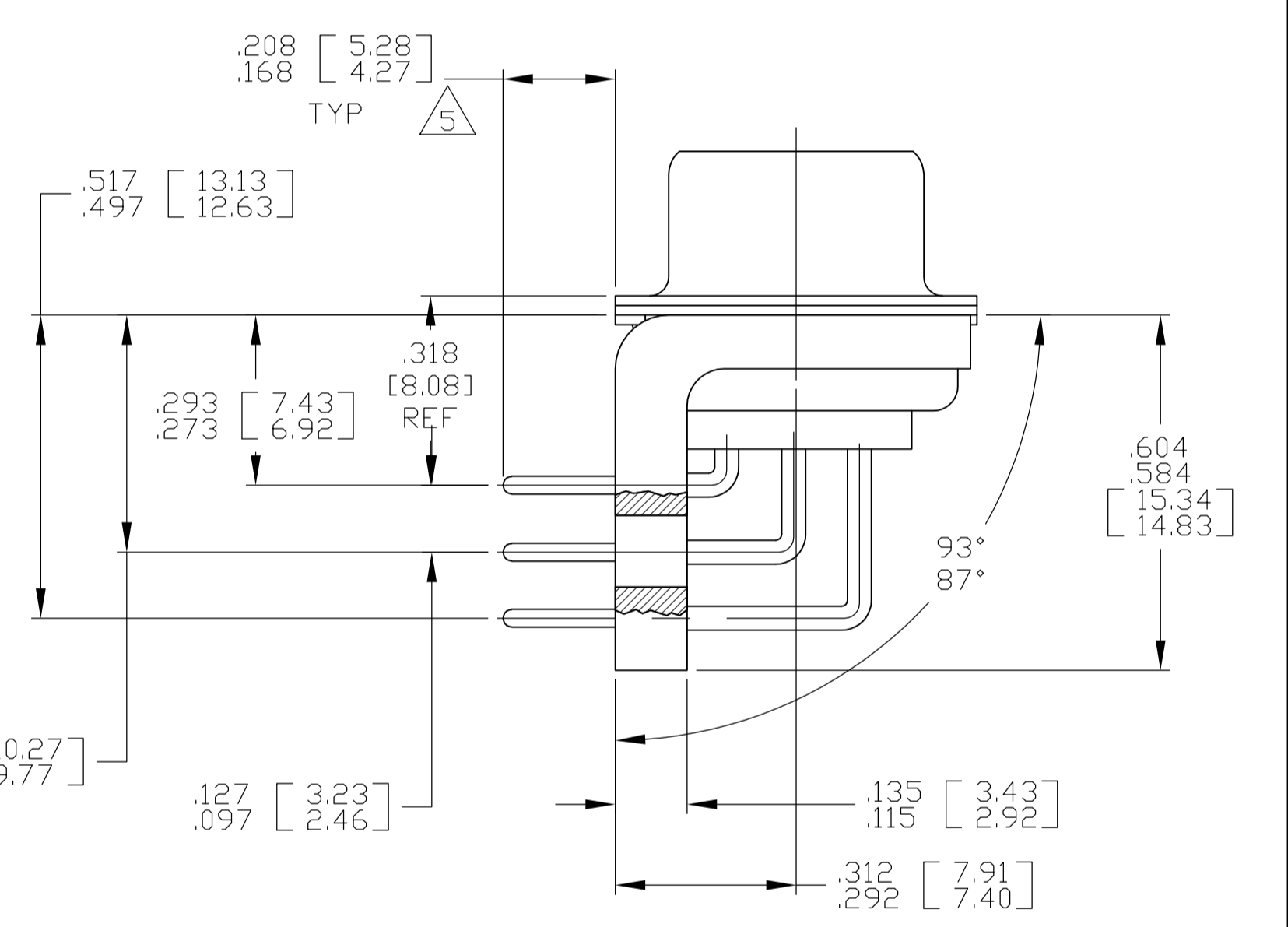

SHELL SIZE 5 CONTACT CONFIGURATION

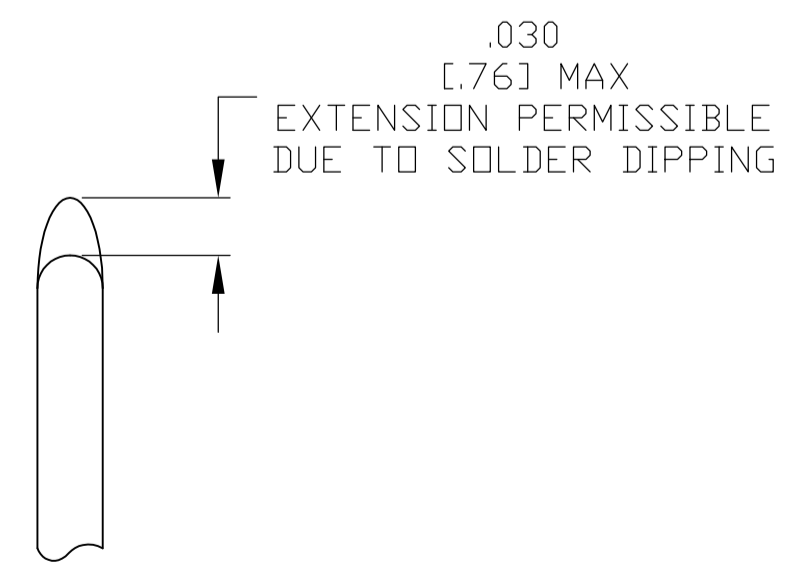

.049	[1.24]	.544	[13.82]	2.188	[55.58]	.236	[5.99]	.436	[11.07]	.620	[15.75]	.446	[11.33]	2.411	[61.24]	2.084	[52.55]	2.650	[67.31]
.029	[0.74]	.412	[10.46]	2.282	[57.96]	.224	[5.69]	.416	[10.57]	.590	[14.99]	.436	[11.07]	2.401	[60.99]	2.074	[52.30]	2.620	[66.55]
.049	[1.24]	.432	[10.97]	2.282	[57.96]	.236	[5.99]	.436	[11.07]	.509	[12.93]	.334	[8.48]	2.505	[63.63]	2.187	[54.97]	2.744	[69.70]
.029	[0.74]	.412	[10.46]	2.262	[57.45]	.224	[5.69]	.416	[10.57]	.479	[12.17]	.324	[8.23]	2.495	[63.37]	2.177	[54.71]	2.714	[68.94]
.049	[1.24]	.432	[10.97]	1.635	[41.53]	.236	[5.99]	.436	[11.07]	.509	[12.93]	.334	[8.48]	1.857	[47.17]	1.539	[38.51]	2.103	[53.42]
.029	[0.74]	.412	[10.46]	1.615	[41.02]	.224	[5.69]	.416	[10.57]	.479	[12.17]	.324	[8.23]	1.847	[46.91]	1.529	[38.25]	2.073	[52.65]
.040	[1.02]	.432	[10.97]	1.093	[27.76]	.238	[6.05]	.432	[10.97]	.509	[12.93]	.334	[8.48]	1.317	[33.45]	.999	[24.79]	1.556	[39.52]
.020	[0.51]	.412	[10.46]	1.073	[27.25]	.229	[5.82]	.412	[10.46]	.479	[12.17]	.324	[8.23]	1.307	[33.20]	.989	[24.54]	1.526	[38.76]
.049	[1.24]	.432	[10.97]	.769	[19.53]	.238	[6.05]	.432	[10.97]	.509	[12.93]	.334	[8.48]	.989	[25.12]	.671	[16.46]	1.228	[31.19]
.029	[0.74]	.412	[10.46]	.749	[19.02]	.229	[5.82]	.412	[10.46]	.479	[12.17]	.324	[8.23]	.979	[24.87]	.661	[16.21]	1.198	[30.43]
.049	[1.24]	.432	[10.97]	2.188	[55.58]	.236	[5.99]	.436	[11.07]	.620	[15.75]	.446	[11.33]	2.411	[61.24]	2.084	[52.55]	2.650	[67.31]
.029	[0.74]	.412	[10.46]	2.262	[57.45]	.224	[5.69]	.416	[10.57]	.590	[14.99]	.436	[11.07]	2.401	[60.99]	2.074	[52.30]	2.620	[66.55]
.049	[1.24]	.432	[10.97]	2.282	[57.96]	.236	[5.99]	.436	[11.07]	.509	[12.93]	.334	[8.48]	2.505	[63.63]	2.187	[54.97]	2.744	[69.70]
.029	[0.74]	.412	[10.46]	2.262	[57.45]	.224	[5.69]	.416	[10.57]	.479	[12.17]	.324	[8.23]	2.495	[63.37]	2.177	[54.71]	2.714	[68.94]
.049	[1.24]	.432	[10.97]	1.635	[41.53]	.236	[5.99]	.436	[11.07]	.509	[12.93]	.334	[8.48]	1.857	[47.17]	1.539	[38.51]	2.103	[53.42]
.029	[0.74]	.412	[10.46]	1.615	[41.02]	.224	[5.69]	.416	[10.57]	.479	[12.17]	.324	[8.23]	1.847	[46.91]	1.529	[38.25]	2.073	[52.65]
.040	[1.02]	.432	[10.97]	1.093	[27.76]	.238	[6.05]	.432	[10.97]	.509	[12.93]	.334	[8.48]	1.317	[33.45]	.999	[24.79]	1.556	[39.52]
.020	[0.51]	.412	[10.46]	1.073	[27.25]	.229	[5.82]	.412	[10.46]	.479	[12.17]	.324	[8.23]	1.307	[33.20]	.989	[24.54]	1.526	[38.76]
.049	[1.24]	.432	[10.97]	.769	[19.53]	.238	[6.05]	.432	[10.97]	.509	[12.93]	.334	[8.48]	.989	[25.12]	.671	[16.46]	1.228	[31.19]
.029	[0.74]	.412	[10.46]	.749	[19.02]	.229	[5.82]	.412	[10.46]	.479	[12.17]	.324	[8.23]	.979	[24.87]	.661	[16.21]	1.198	[30.43]

DIM L	DIM J	DIM H	DIM G	DIM F	DIM E	DIM D	DIM C	DIM B	DIM A	INSERT ARRANGEMENT	NO OF POS	SHELL SIZE	MILITARY P/N ON CONNECTOR	MFG'S P/N MARKED ON CONNECTOR	MFG'S PART NO.
										3			3		

DETAIL K
SCALE 10:1
FOR 1757845-6 THRU -10 ONLY

THIS DRAWING IS A CONTROLLED DOCUMENT.

DTN: C.C. THOMAS 10FEB2008
CHK: D. MILLER 2-13-06
APPV: D. MILLER 2-13-06

TE Connectivity

PLUG ASSEMBLY, AMP/LITE, RT ANGLE, SERIES 109, SIZE 1 THRU 5

APPLICATION SPEC: 00779

SIZE: A1 CASE CODE: 1757845 DRAWING NO: 1757845

SCALE: 4:1 SHEET: 1 OF 2 REV: B

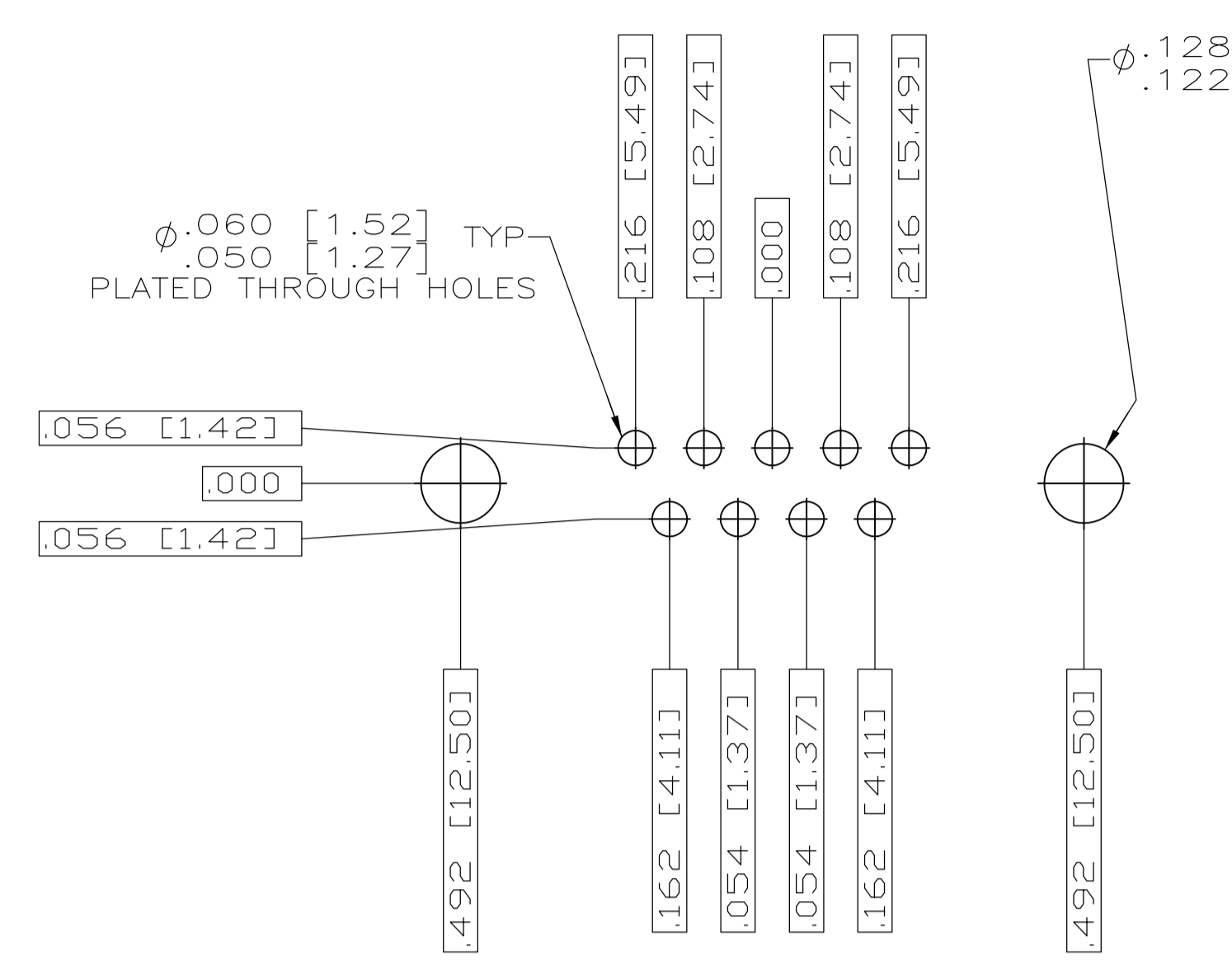

RECOMMENDED P.C. BOARD LAYOUT
SHELL SIZE 1 (9 POSITION) ⚠

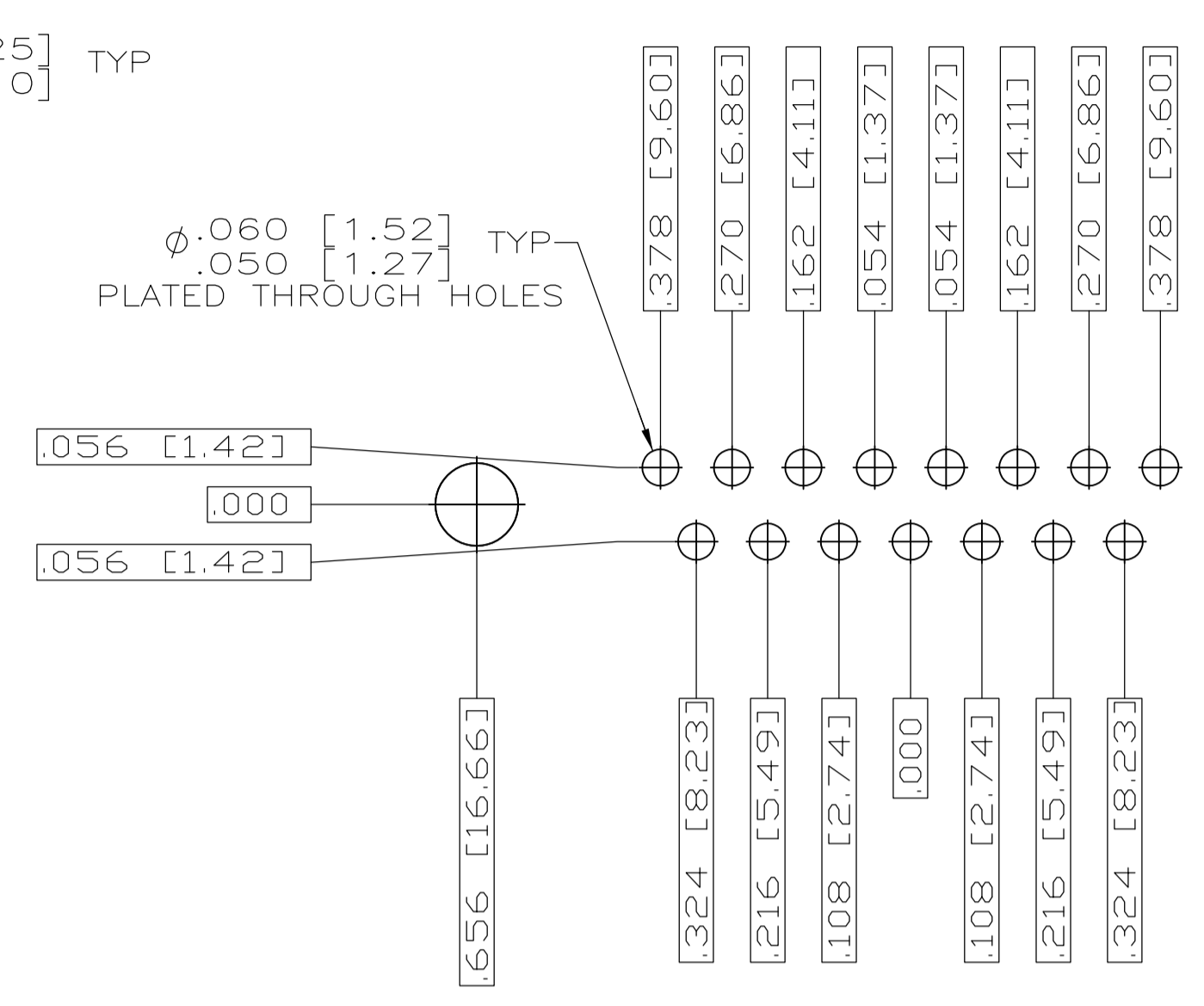

RECOMMENDED P.C. BOARD LAYOUT
SHELL SIZE 2 (15 POSITION) ⚠

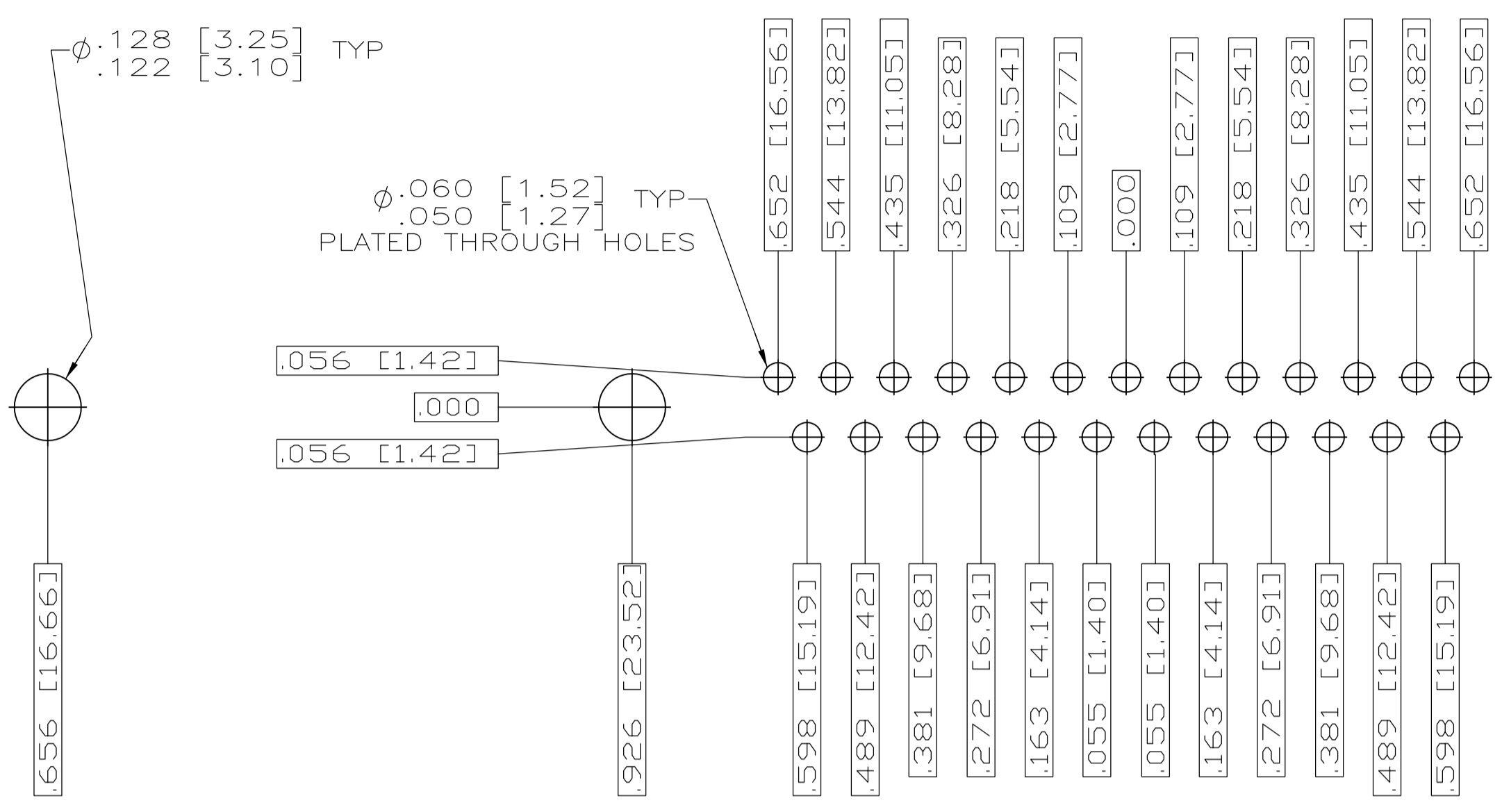

RECOMMENDED P.C. BOARD LAYOUT
SHELL SIZE 3 (25 POSITION) ⚠

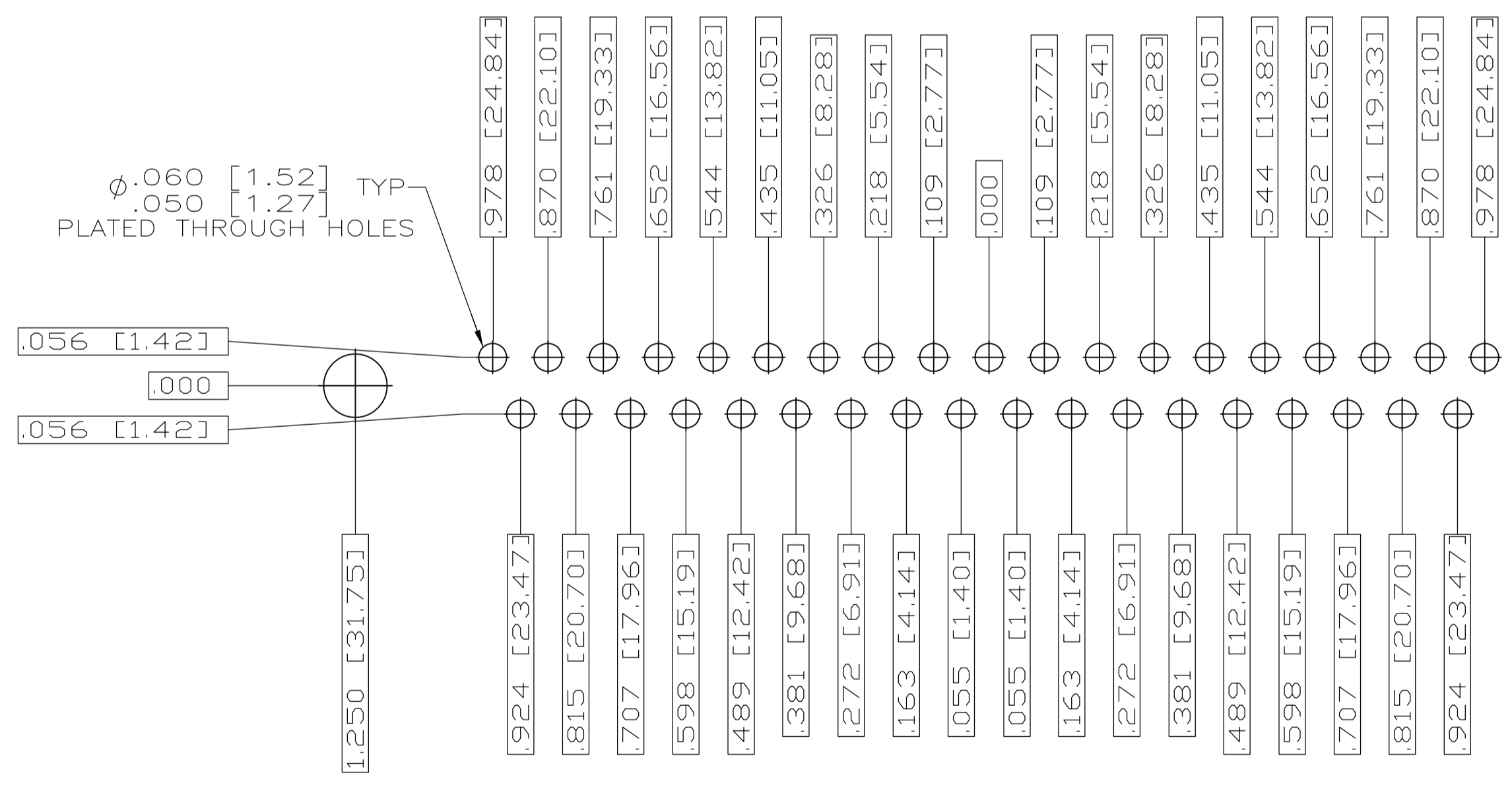

RECOMMENDED P.C. BOARD LAYOUT
SHELL SIZE 4 (37 POSITION) ⚠

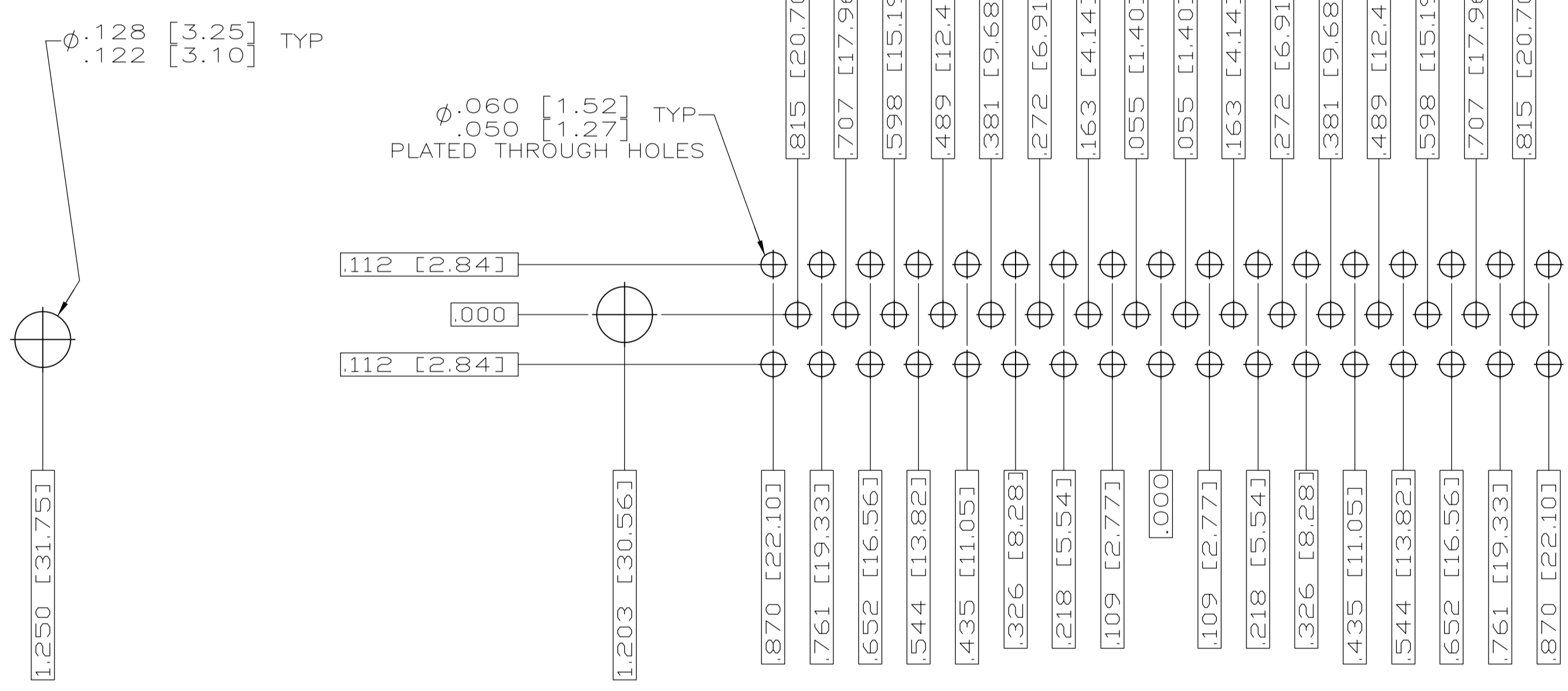

RECOMMENDED P.C. BOARD LAYOUT
SHELL SIZE 5 (50 POSITION) ⚠

THIS DRAWING IS A CONTROLLED DOCUMENT.		DN C.C.THOMAS	2-10-06	TE Connectivity
DIMENSIONS: INCHES		CHK D.HOFFMAN	2-23-06	
TOLERANCES UNLESS OTHERWISE SPECIFIED:		APVD D.MILLER	2-23-06	NAME PLUG ASSY,AMPLIMITE RIGHT ANGLE,SERIES 109,SIZE 1 THRU 5
0 PL ±	1 PL ±	APPLICATION SPEC		SIZE A1
2 PL ±	3 PL ±	MATERIAL SEE CALLOUTS		CAGE CODE 00779
4 PL ±	FINISH SEE CALLOUTS	WEIGHT		DRAWING NO 1757845
CUSTOMER DRAWING		SCALE 4:1		RESTRICTED TO SHEET 2 OF 2

Компания «Life Electronics» занимается поставками электронных компонентов импортного и отечественного производства от производителей и со складов крупных дистрибьюторов Европы, Америки и Азии.

С конца 2013 года компания активно расширяет линейку поставок компонентов по направлению коаксиальный кабель, кварцевые генераторы и конденсаторы (керамические, пленочные, электролитические), за счёт заключения дистрибьюторских договоров

Мы предлагаем:

- Конкурентоспособные цены и скидки постоянным клиентам.
- Специальные условия для постоянных клиентов.
- Подбор аналогов.
- Поставку компонентов в любых объемах, удовлетворяющих вашим потребностям.
- Приемлемые сроки поставки, возможна ускоренная поставка.
- Доставку товара в любую точку России и стран СНГ.
- Комплексную поставку.
- Работу по проектам и поставку образцов.
- Формирование склада под заказчика.
- Сертификаты соответствия на поставляемую продукцию (по желанию клиента).
- Тестирование поставляемой продукции.
- Поставку компонентов, требующих военную и космическую приемку.
- Входной контроль качества.
- Наличие сертификата ISO.

В составе нашей компании организован Конструкторский отдел, призванный помогать разработчикам, и инженерам.

Конструкторский отдел помогает осуществить:

- Регистрацию проекта у производителя компонентов.
- Техническую поддержку проекта.
- Защиту от снятия компонента с производства.
- Оценку стоимости проекта по компонентам.
- Изготовление тестовой платы монтаж и пусконаладочные работы.



Тел: +7 (812) 336 43 04 (многоканальный)

Email: org@lifeelectronics.ru