

LOC	DIST	REVISIONS			
P	LTN	DESCRIPTION	DATE	DMN	APVD
C		REVISED PER ECO-10-018054	04NOV2010	CJV	EJB
D		REVISED PER ECO-12-003481	15MAR2012	KS	AC
E		REVISED PER ECO-12-005533	31MAR2012	JY	AC
F		REVISED PER ECO-14-017735	30EC2014	RG	MC

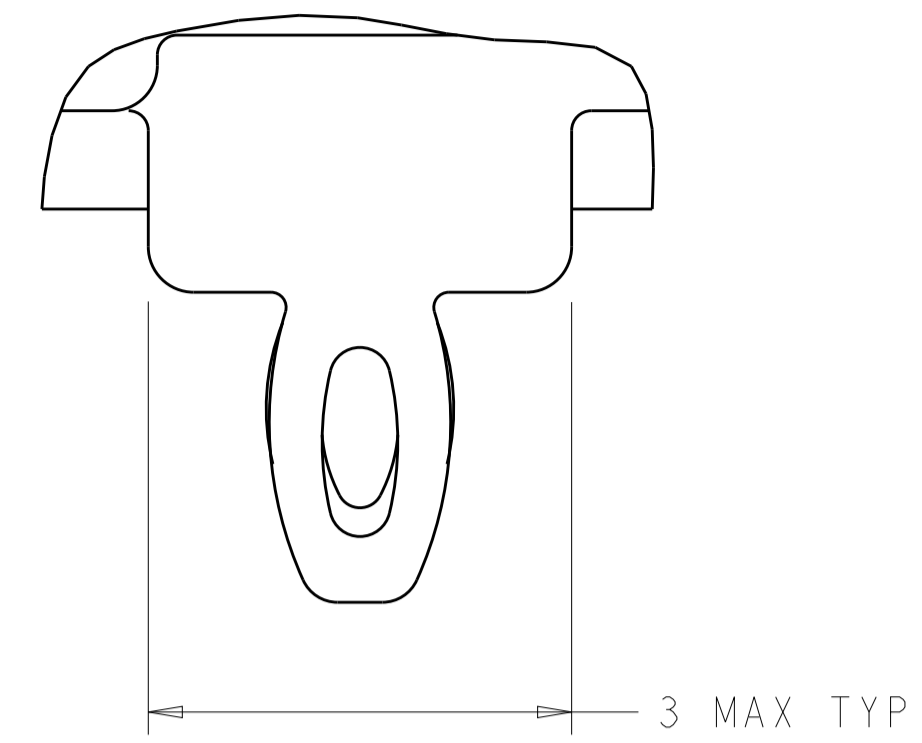

DETAIL S
 SCALE 20:1

- 1 CAGE ASSEMBLY MATERIAL: NICKEL SILVER, 0.25 THICK
 HEAT SINK MATERIAL: ALUMINUM
 HEAT SINK CLIP MATERIAL: STAINLESS STEEL
 EMI SPRING MATERIAL: COPPER ALLOY
 FRONT FLANGE MATERIAL: ZINC ALLOY
 LIGHT PIPE MATERIAL: CLEAR POLYCARBONATE
- 2 PITCH BETWEEN PORTS OF ONE 1X4 CAGE ASSEMBLY.
- 3 SPACING BETWEEN CAGES ON THE SAME PC BOARD, TO BE SPECIFIED BY CUSTOMER, MUST COMPLY WITH MINIMUM DIMENSIONS SHOWN.
- 4 REFERENCE APPLICATION SPEC 114-13218 FOR RECOMMENDED DRILL HOLE DIAMETER AND PLATING THICKNESS.
- 5 DATUMS AND BASIC DIMENSIONS ESTABLISHED BY CUSTOMER.
- 6 DIMENSION F IS THE NOMINAL THICKNESS OF CUSTOMER SUPPLIED PC BOARD,
 SINGLE SIDED PC BOARD MINIMUM THICKNESS = 1.45mm
 DOUBLE SIDED PC BOARD MINIMUM THICKNESS = 2.2mm PER QSFP.
- 7 HEAT SINKS, LIGHT PIPES, AND HEAT SINK CLIPS SHIPPED ASSEMBLED TO CAGE ASSEMBLY. CAGE ASSEMBLY MAY BE PRESSED INTO THE PCB AS SHIPPED.
- 8 DATUM -A- IS TOP SURFACE OF PC BOARD.
- 9 DIMENSION APPLIES WITH MODULE INSERTED IN CAGE.
- 10 UNPLATED THRU HOLE.
- 11 MATES WITH QSFP MSA COMPATIBLE TRANSCEIVER.
- 12 SURFACE TRACES PERMITTED WITHIN THIS AREA EXCEPT WHERE CAGE STANDOFFS, SHOWN IN DETAIL S, CONTACT PC BOARD.
- 13 BASELINE FOR THESE DIMENSIONS IS THE CENTER OF COMPLIANT PIN HOLE.
- 14 2D BARCODE AND DATE CODE (YYWW) MARKED ON SIDE OF CAGE ASSEMBLY.

- 15 REFERENCE APP SPEC 114-13218 FOR GASKET THICKNESS CALCULATION.
- 16 EMI SPRING FINISH: 2µm MINIMUM TIN
 FRONT FLANGE FINISH: 3µm MINIMUM TIN OVER 1.27µm MINIMUM NICKEL
 OVER 5.08µm MINIMUM COPPER.
 HEAT SINK FINISH: NICKEL
- 17 HEAT SINKS AND CLIPS SHIPPED ASSEMBLED TO CAGE ASSEMBLY. CAGE ASSEMBLY MAY BE PRESSED INTO THE PCB AS SHIPPED. LIGHT PIPES, SHIPPED UNATTACHED, MUST BE ASSEMBLED BY CUSTOMER AFTER THE CASE IS SEATED IN THE PCB.

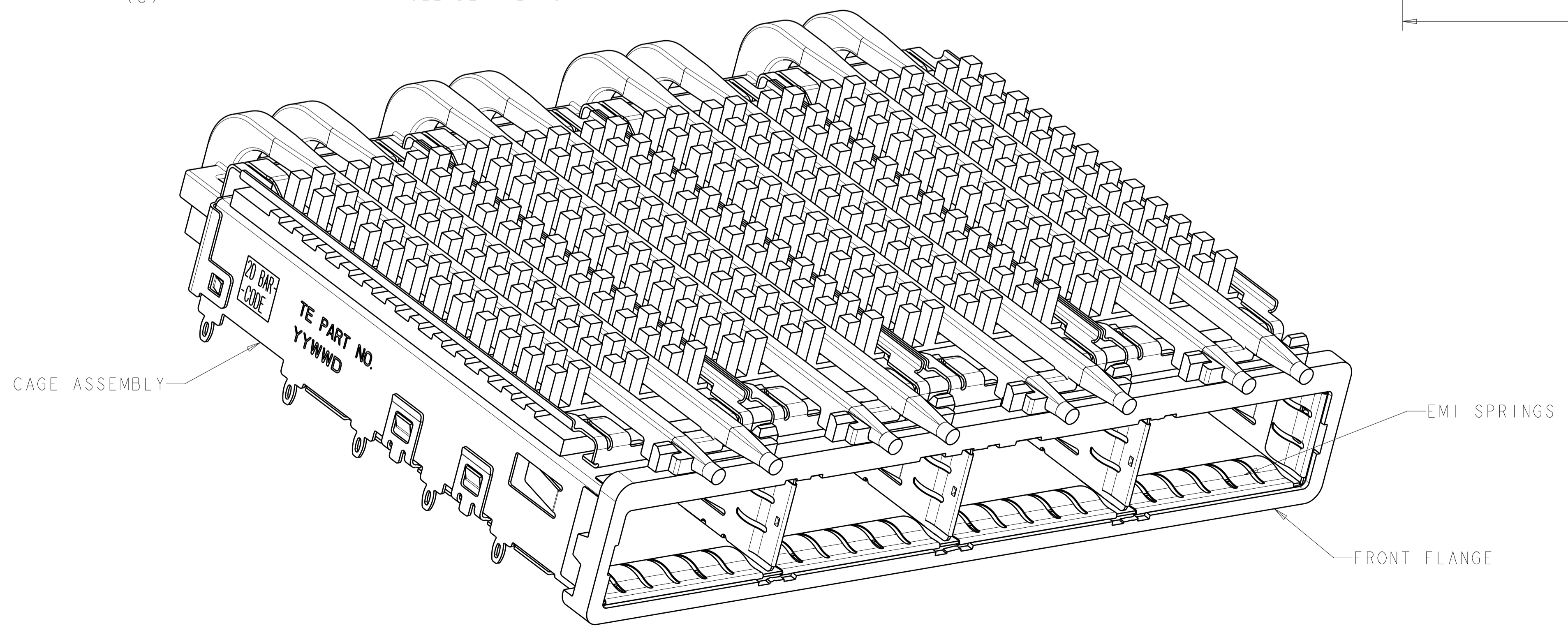
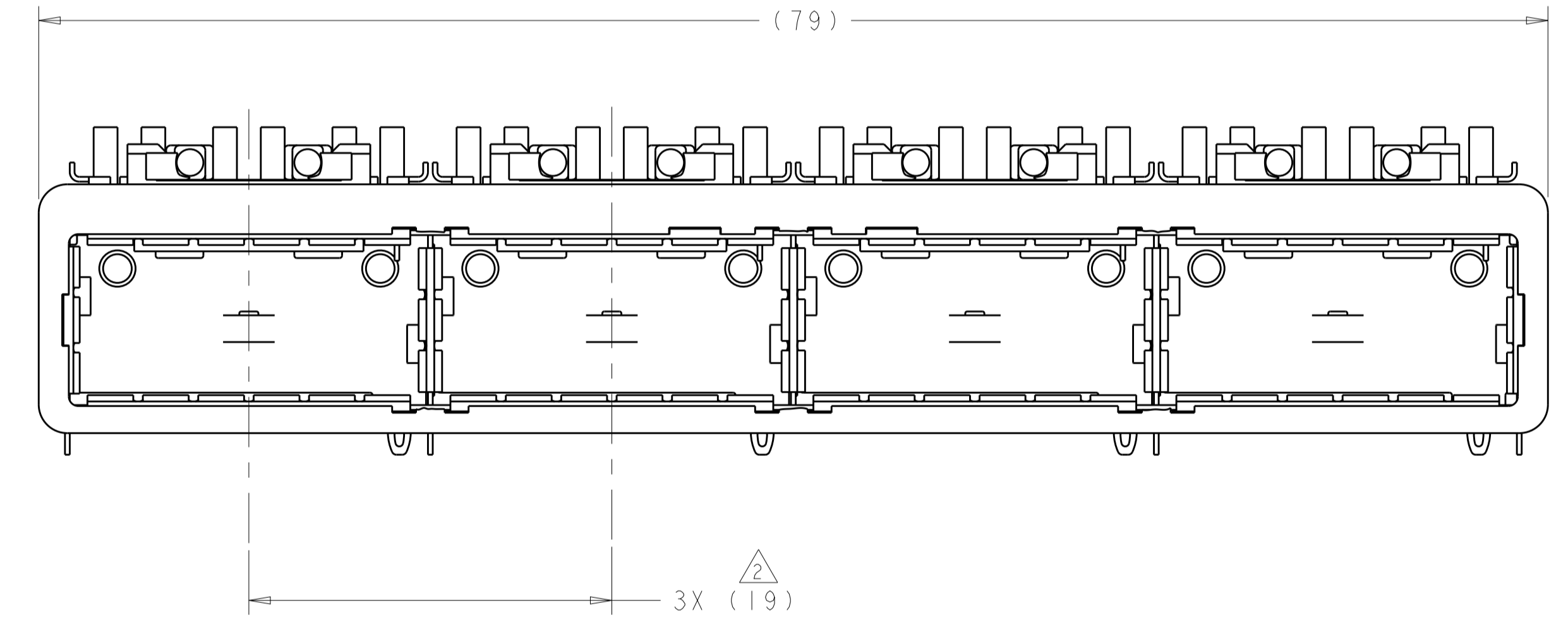
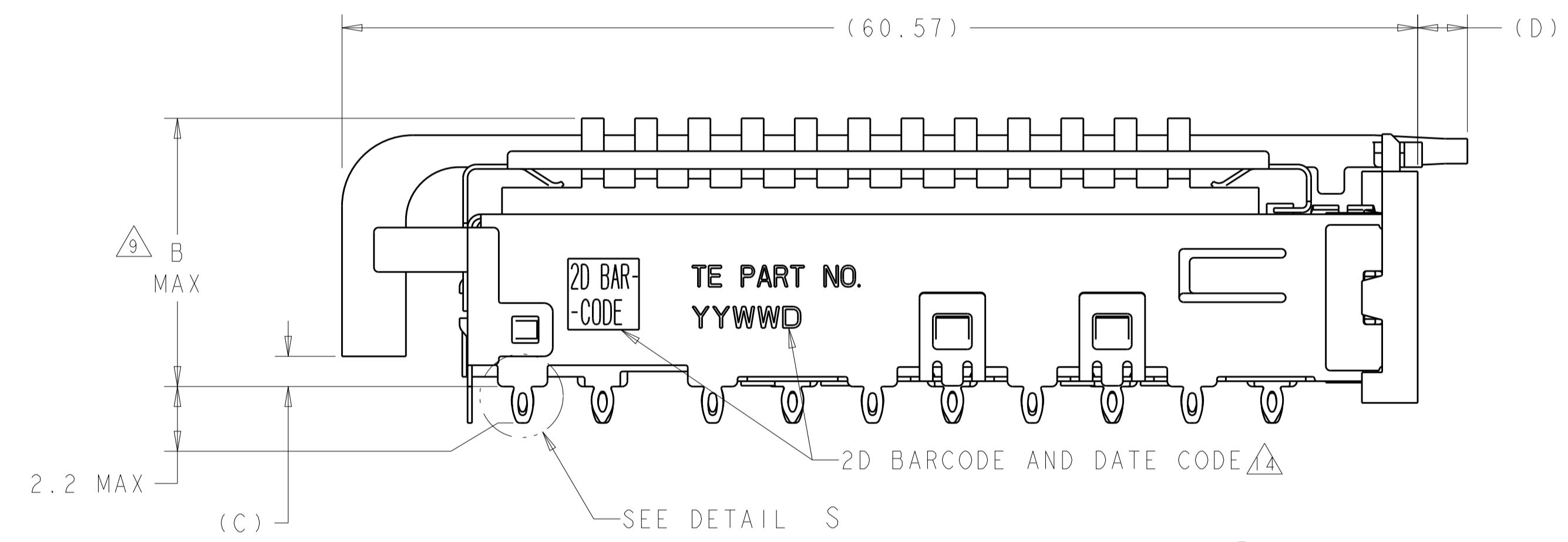

	E	D	C	B	HEAT SINK PROFILE	PART NUMBER
7	1.3-1.4	5.7	2.15	16.0	SAN	2057183-5
11	1.3-1.4	5.7	2.15	13.7	PCI	2057183-4
7	0.8-1.1	2.8	1.70	23.0	NETWORKING	2057183-3
7	0.8-1.1	2.8	1.70	16.0	SAN	2057183-2
11	0.8-1.1	2.8	1.70	13.7	PCI	2057183-1

THIS DRAWING IS A CONTROLLED DOCUMENT. DMN: C. VALENTINE 01MAY2008
 CHK: E. BRIGHT 01MAY2008
 APVD: F. BRIGHT 01MAY2008

STE TE Connectivity

NAME: 1X4 CAGE ASSEMBLY, BEHIND BEZEL, W/ LIGHT PIPES AND HEAT SINKS, QSFP

PRODUCT SPEC: 108-2286
 APPLICATION SPEC: 114-13218

SIZE: A1 CAGE CODE: 00779 DRAWING NO: 2057183

MATERIAL: NICKEL SILVER
 FINISH: 0.25 THICK

CUSTOMER DRAWING SCALE: 4:1 SHEET 1 OF 5 REV F

LOC	DIST	REVISIONS					
GP	00	P.	LYR	DESCRIPTION	DATE	DWN	APVD
		-		SEE SHEET 1			

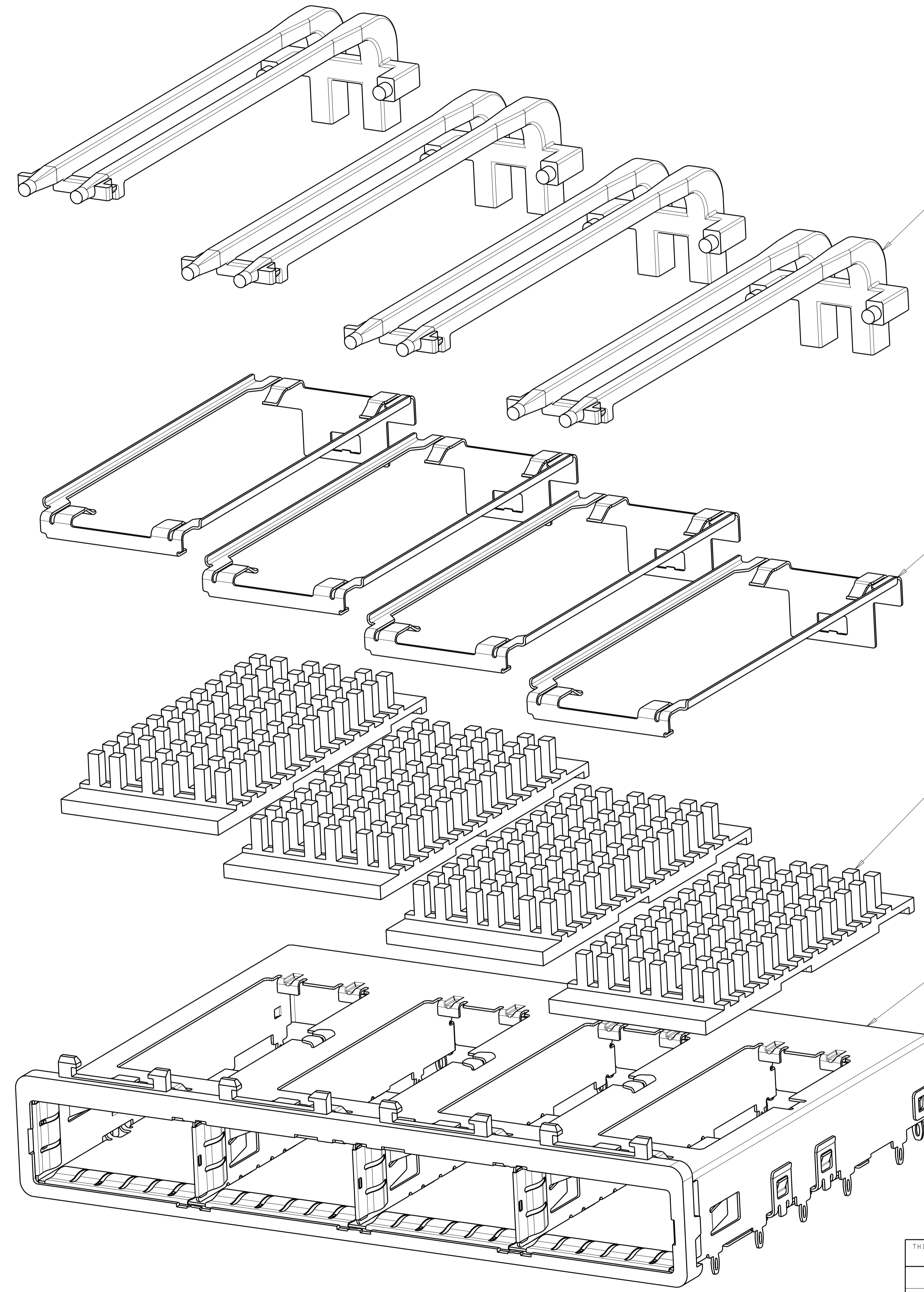

DOUBLE LIGHT PIPES ∇/∇
 QUANTITY: 4

HEAT SINK CLIPS ∇/∇
 QUANTITY: 4

72 PIN HEAT SINKS ∇/∇
 QUANTITY: 4

1X4 BEHIND BEZEL QSFP
 CAGE ASSEMBLY
 QUANTITY: 1

THIS DRAWING IS A CONTROLLED DOCUMENT.		DWN C. VALENTINE 01MAY2008	TE Connectivity
DIMENSIONS: mm		CHK E. BRIGHT 01MAY2008	
		APVD E. BRIGHT 01MAY2008	NAME 1X4 CAGE ASSEMBLY, BEHIND BEZEL, W/ LIGHT PIPES AND HEAT SINKS, QSFP
TOLERANCES UNLESS OTHERWISE SPECIFIED:		PRODUCT SPEC	SIZE A100779C=2057183
0 PLC ±		108-2286	RESTRICTED TO
1 PLC ±0.1		APPLICATION SPEC	
2 PLC ±		114-13218	
3 PLC ±		WEIGHT	
4 PLC ±		CUSTOMER DRAWING	
ANGLES ±		SCALE 4:1	SHEET 2 OF 5
FINISH		REV F	

LOC	DIST	REV	DATE	BY	APPD
GP	00				

REVISIONS			
NO.	DESCRIPTION	DATE	BY
-	SEE SHEET 1	-	-

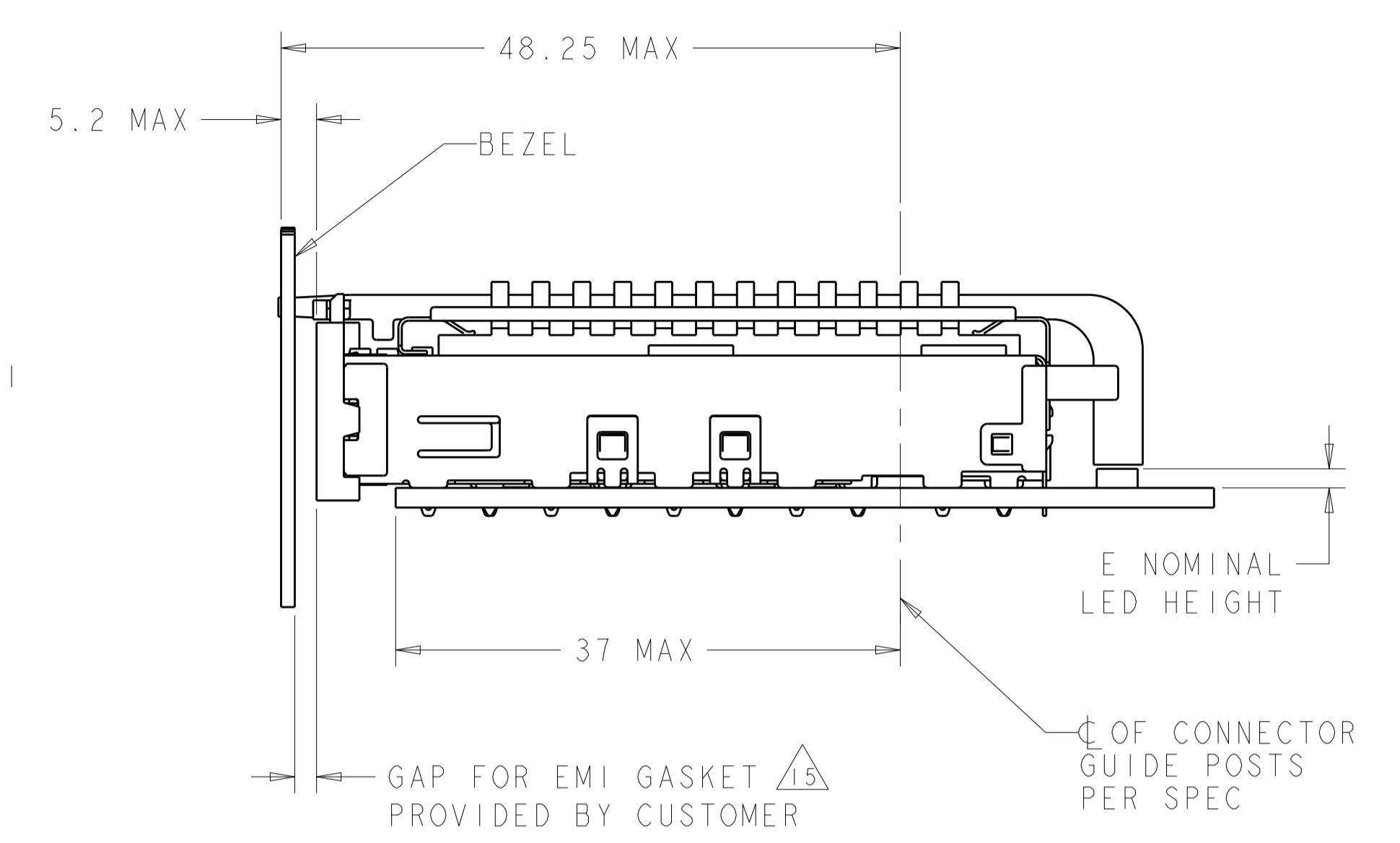
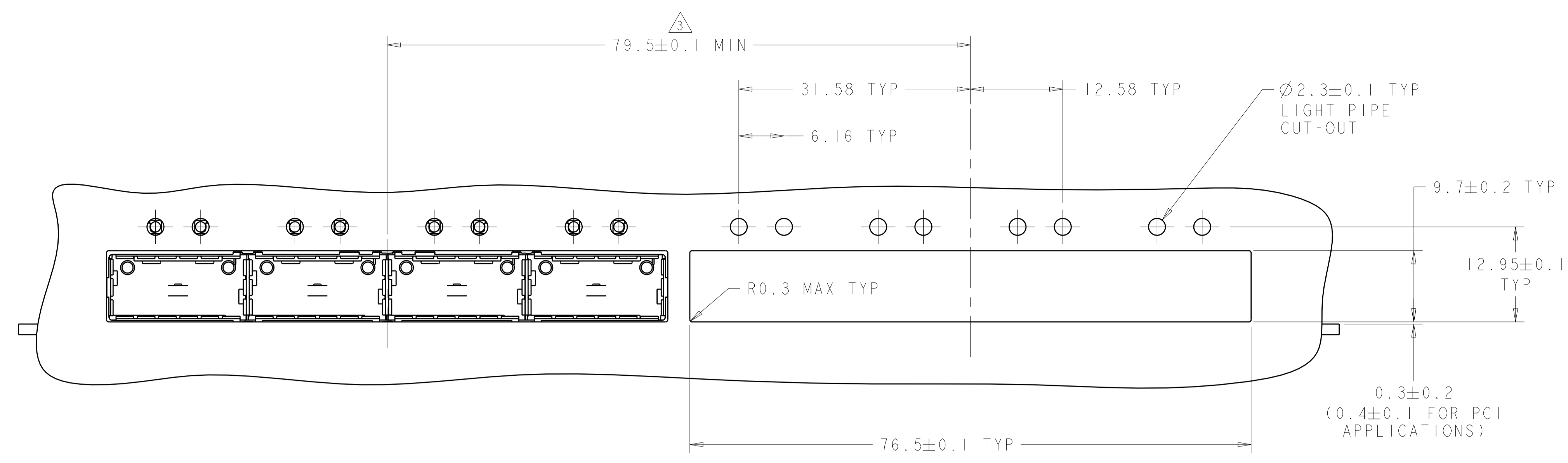

ONE SIDED CONFIGURATION
 SCALE 5:2

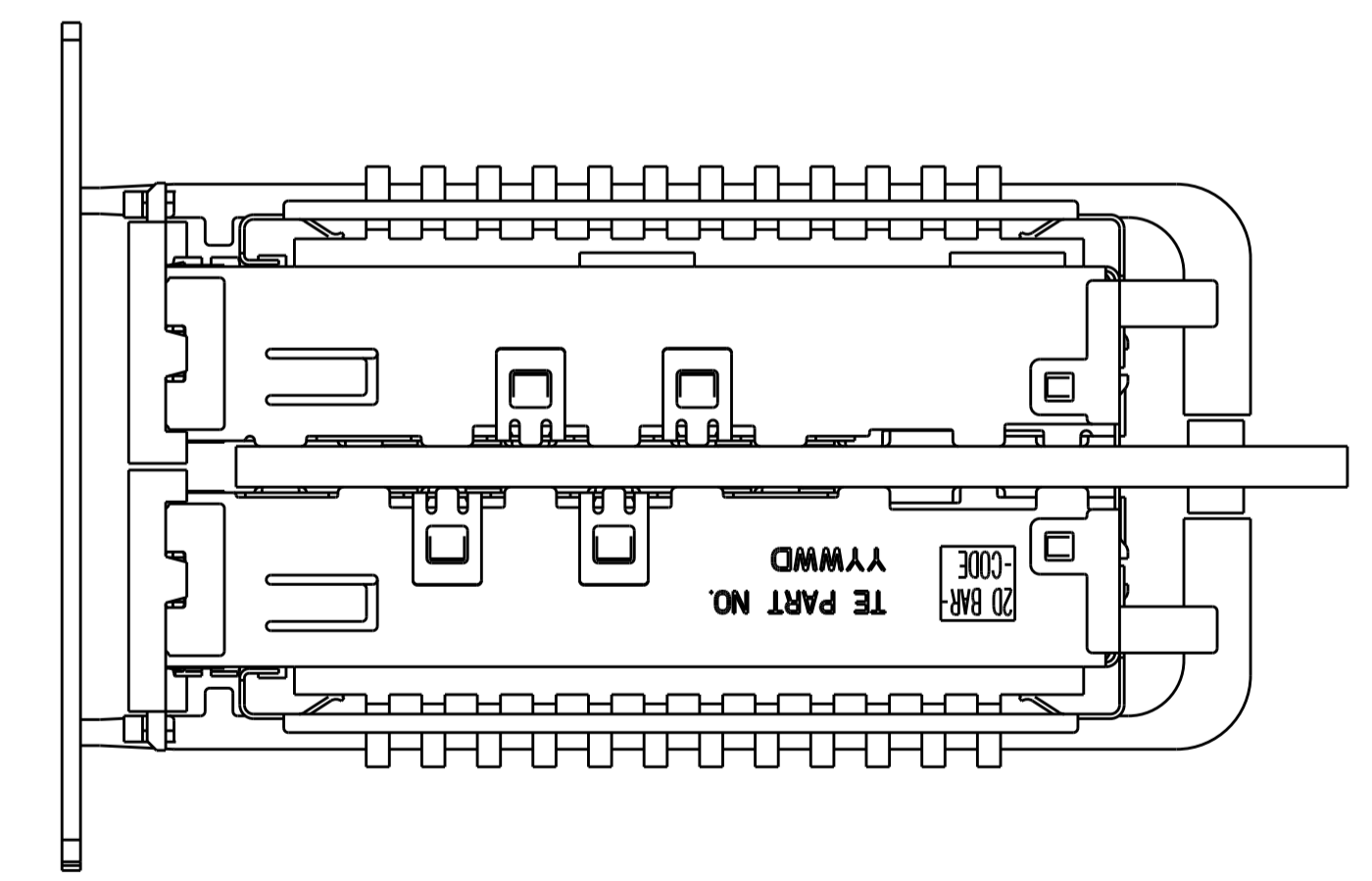
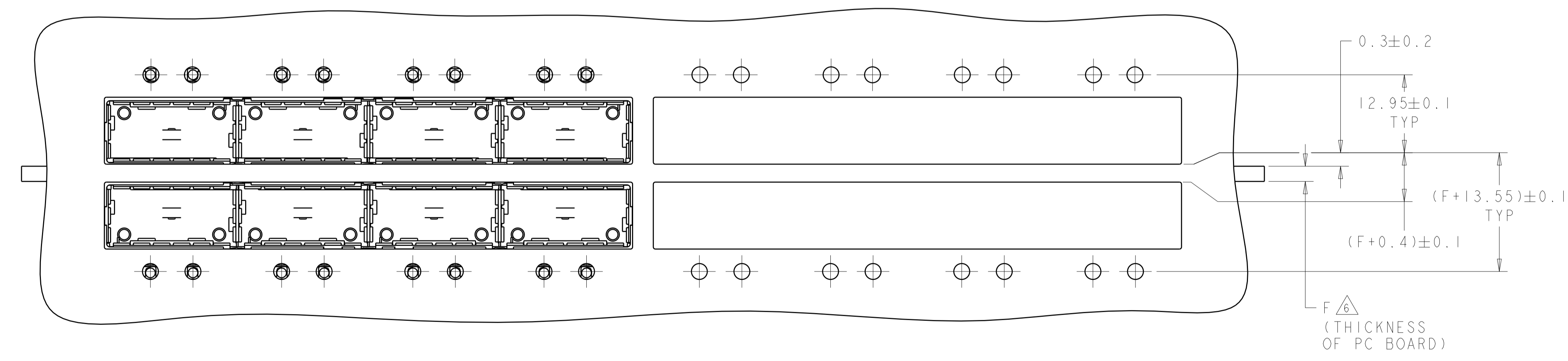

BELLY TO BELLY CONFIGURATION
 SIMILAR TO ONE SIDED
 EXCEPT WHERE NOTED
 SCALE 5:2

THIS DRAWING IS A CONTROLLED DOCUMENT.		OWN: C. VALENTINE 01MAY2008	TE Connectivity
DIMENSIONS: mm		CHK: E. BRIGHT 01MAY2008	
TOLERANCES UNLESS OTHERWISE SPECIFIED:		APVD: E. BRIGHT 01MAY2008	NAME: 1X4 CAGE ASSEMBLY, BEHIND BEZEL, W/ LIGHT PIPES AND HEAT SINKS, QSFP
0 PLC ±		PRODUCT SPEC: 108-2286	
1 PLC ±0.1		APPLICATION SPEC: 114-13218	SIZE: A100779C=2057183
2 PLC ±0.1		WEIGHT: -	
3 PLC ±		CUSTOMER DRAWING	RESTRICTED TO: -
4 PLC ±		SCALE: 4:1	SHEET: 3 OF 5
ANGLES ±			REV: F
FINISH -			

LOC	DIST	REV	DATE	BY	APPD
GP	00				

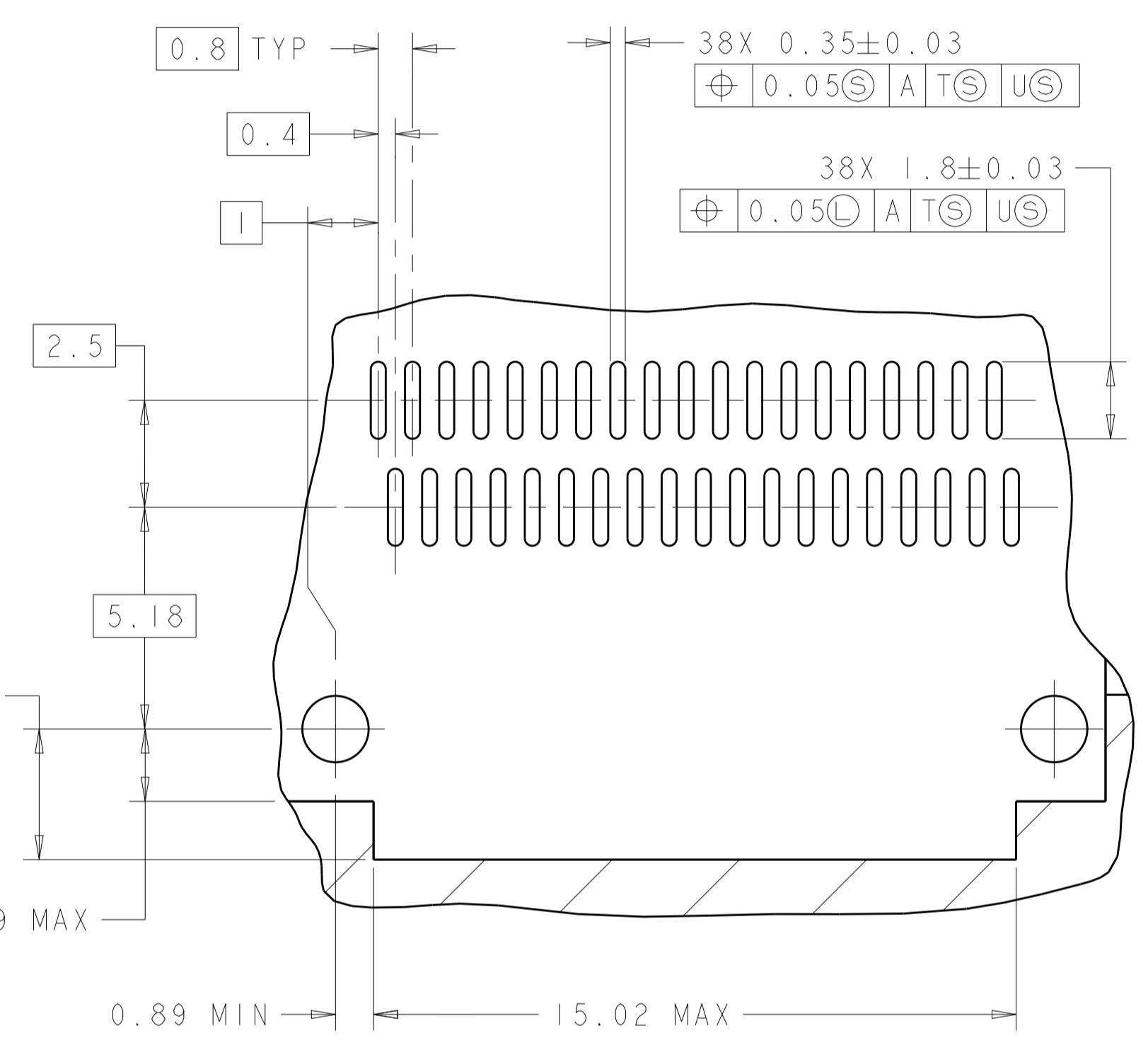
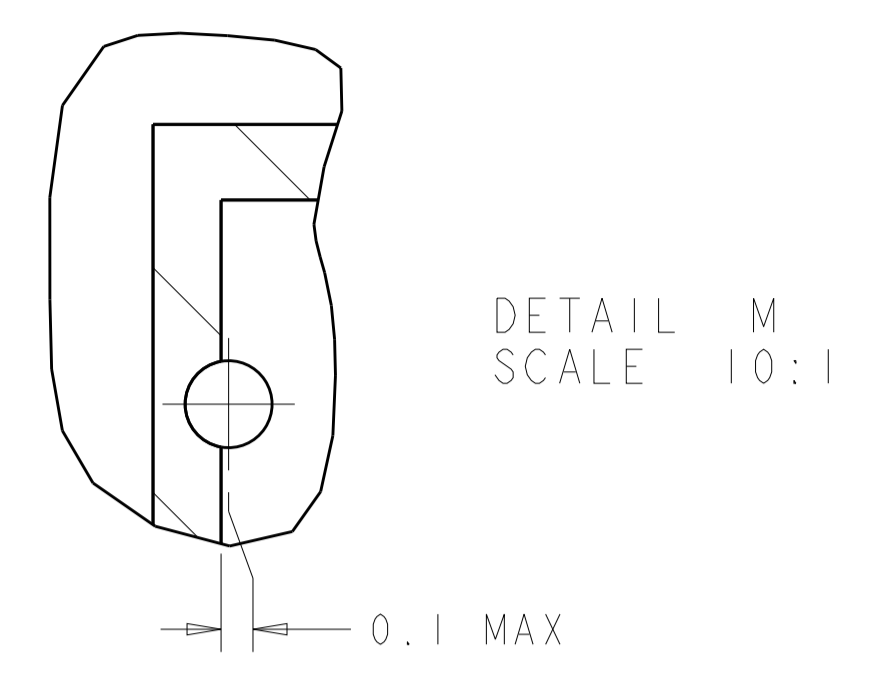
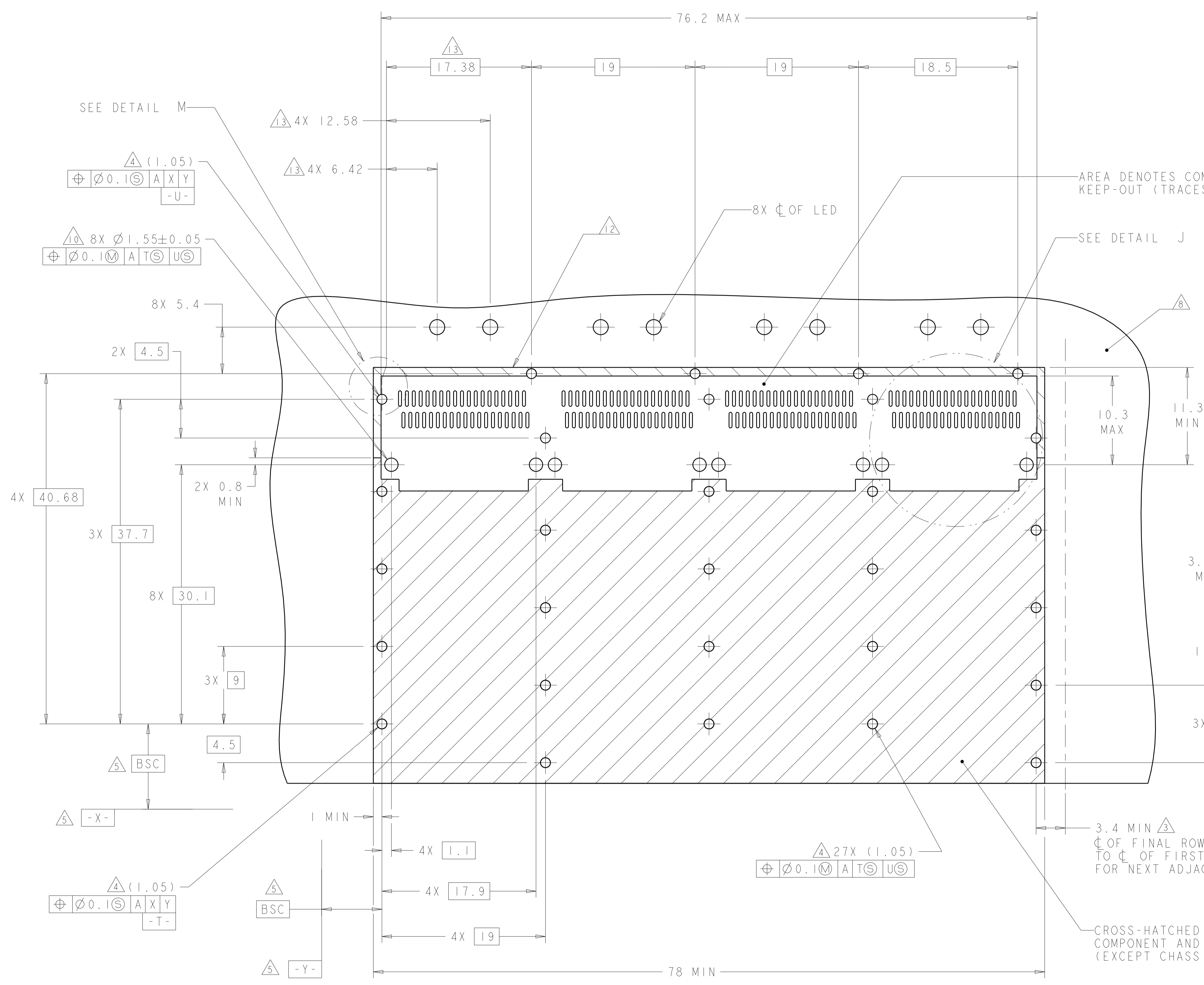

RECOMMENDED PC BOARD LAYOUT
 SINGLE SIDE MOUNT CONFIGURATION
 SCALE 4:1

THIS PRODUCT HAS NOT COMPLETED VALIDATION/QUALIFICATION TESTING

3.4 MIN Δ
 ϕ OF FINAL ROW OF HOLES
 TO ϕ OF FIRST ROW OF HOLES
 FOR NEXT ADJACENT CAGE

CROSS-HATCHED AREA DENOTES
 COMPONENT AND TRACE KEEP-OUT
 (EXCEPT CHASSIS GROUND)

THIS DRAWING IS A CONTROLLED DOCUMENT.		OWN C. VALENTINE 01MAY2008	TE Connectivity												
DIMENSIONS: mm		CHK E. BRIGHT 01MAY2008													
TOLERANCES UNLESS OTHERWISE SPECIFIED:		APVD E. BRIGHT 01MAY2008	NAME 1X4 CAGE ASSEMBLY, BEHIND BEZEL, W/ LIGHT PIPES AND HEAT SINKS, QSFP												
<table border="1"> <tr> <td>0 PLC</td> <td>±</td> </tr> <tr> <td>1 PLC</td> <td>±0.1</td> </tr> <tr> <td>2 PLC</td> <td>±0.1</td> </tr> <tr> <td>3 PLC</td> <td>±</td> </tr> <tr> <td>4 PLC</td> <td>±</td> </tr> <tr> <td>ANGLES</td> <td>±</td> </tr> </table>		0 PLC	±	1 PLC	±0.1	2 PLC	±0.1	3 PLC	±	4 PLC	±	ANGLES	±	PRODUCT SPEC 108-2286	SIZE A1
0 PLC	±														
1 PLC	±0.1														
2 PLC	±0.1														
3 PLC	±														
4 PLC	±														
ANGLES	±														
MATERIAL		APPLICATION SPEC 114-13218	RESTRICTED TO												
FINISH		WEIGHT	SCALE 4:1 SHEET 4 OF 5 REV F												
		CUSTOMER DRAWING													

Компания «Life Electronics» занимается поставками электронных компонентов импортного и отечественного производства от производителей и со складов крупных дистрибьюторов Европы, Америки и Азии.

С конца 2013 года компания активно расширяет линейку поставок компонентов по направлению коаксиальный кабель, кварцевые генераторы и конденсаторы (керамические, пленочные, электролитические), за счёт заключения дистрибьюторских договоров

Мы предлагаем:

- Конкуренспособные цены и скидки постоянным клиентам.
- Специальные условия для постоянных клиентов.
- Подбор аналогов.
- Поставку компонентов в любых объемах, удовлетворяющих вашим потребностям.
- Приемлемые сроки поставки, возможна ускоренная поставка.
- Доставку товара в любую точку России и стран СНГ.
- Комплексную поставку.
- Работу по проектам и поставку образцов.
- Формирование склада под заказчика.
- Сертификаты соответствия на поставляемую продукцию (по желанию клиента).
- Тестирование поставляемой продукции.
- Поставку компонентов, требующих военную и космическую приемку.
- Входной контроль качества.
- Наличие сертификата ISO.

В составе нашей компании организован Конструкторский отдел, призванный помогать разработчикам, и инженерам.

Конструкторский отдел помогает осуществить:

- Регистрацию проекта у производителя компонентов.
- Техническую поддержку проекта.
- Защиту от снятия компонента с производства.
- Оценку стоимости проекта по компонентам.
- Изготовление тестовой платы монтаж и пусконаладочные работы.



Тел: +7 (812) 336 43 04 (многоканальный)

Email: org@lifeelectronics.ru