



SY898530U

500MHz 1:16 3.3V-to-2.5V LVPECL
Fanout Buffer

General Description

The SY898530U is a 1:16 Fanout buffer which can accept most standard differential logic levels and outputs the signal as a differential 2.5V LVPECL signal. The part can amplify input signals as small as 150mVpp to the full LVPECL output swing. The SY898530U is well suited for clock distribution applications which demand versatility and low-skew performance. It is pin-to-pin compatible with IDT's ICS8530 fanout buffer.

The SY898530U operates from a 3.3V $\pm 5\%$ core power supply and a 2.5V $\pm 5\%$ output supply and is guaranteed over the full commercial temperature range (0°C to +70°C). It is available in a 48-pin TQFP lead-free package.

Data sheets and support documentation can be found on Micrel's web site at www.micrel.com.

Functional Block Diagram

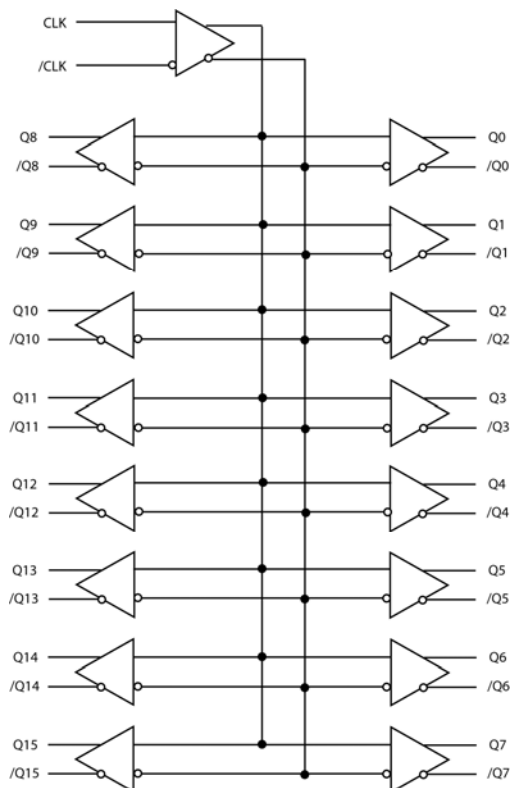

Features

- 16 Differential 2.5V LVPECL outputs
- Differential CLK inputs. Accepts LVDS, LVPECL, LVHSTL, SSTL, HCSL logic levels
- Translates any single-ended input signal to 2.5V LVPECL levels with a resistor bias on /CLK input
- 500MHz maximum output frequency
- <50ps output skew
- <250ps part-to-part skew
- <2ns propagation delay
- 3.3V Core, 2.5V output operating supply
- 0°C to +70°C operating temperature
- Available in 48-pin TQFP package
- Pin-to-pin compatible with ICS8530

Applications

- Data distribution
- High-performance PCs
- Communications
- Parallel processor-based systems

Precision Edge is a registered trademark of Micrel, Inc.

Micrel Inc. • 2180 Fortune Drive • San Jose, CA 95131 • USA • tel +1 (408) 944-0800 • fax + 1 (408) 474-1000 • <http://www.micrel.com>

January 2011

M9999-013111-C
hbwhelp@micrel.com or (408) 955-1690

Ordering Information

Part Number	Package Type	Operating Range	Package Marking	Lead Finish
SY898530UTZ	TQFP-48	Commercial	SY898530UTZ with Pb-Free bar-line indicator	Matte-Sn
SY898530UTZTR ⁽²⁾	TQFP-48	Commercial	SY898530UTZ with Pb-Free bar-line indicator	Matte-Sn
SY898530UTZTX ^(2, 3)	TQFP-48	Commercial	SY898530UTZ with Pb-Free bar-line indicator	Matte-Sn

Notes:

1. Contact factory for die availability. Dice are guaranteed at T_A = 25°C, DC Electricals only.
2. Tape and Reel.
3. EIA specification orientation.

Pin Configuration

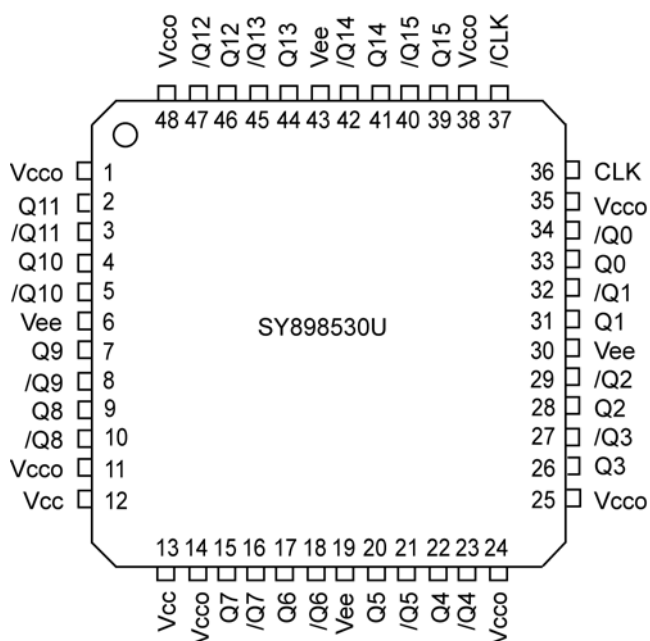

48-Pin TQFP (TQFP-48)

Pin Description

Pin Number	Pin Name	Pin Function
36, 37	CLK, /CLK	Differential Clock Inputs. Accepts LVDS, LVPECL, LVHSTL, SSTL, HCSL logic levels. CLK is internally connected to a pull-down resistor, /CLK is internally connected to a pull-up resistor. See "Pin Characteristics" for typical values.
33, 34 31, 32 28, 29 26, 27 22, 23 20, 21 17, 18 15, 16 9, 10 7, 8 4, 5 2, 3 46, 47 44, 45 41, 42 39, 40	Q0, /Q0 Q1, /Q1 Q2, /Q2 Q3, /Q3 Q4, /Q4 Q5, /Q5 Q6, /Q6 Q7, /Q7 Q8, /Q8 Q9, /Q9 Q10, /Q10 Q11, /Q11 Q12, /Q12 Q13, /Q13 Q14, /Q14 Q15, /Q15	2.5V LVPECL Differential Output Pairs. Differential buffered copies of the input signal. The output swing is typically 740mV. See Interface Applications for termination information.
1, 11, 14, 24, 25, 35, 38, 48	VCCO	Output Power Supply: Bypass with 0.1 μ F//0.01 μ F low ESR capacitors as close to the VCCO pins as possible. Supplies the output buffers.
12, 13	VCC	Core Power Supply: Bypass with 0.1 μ F//0.01 μ F low ESR capacitors as close to the VCC pins as possible. Supplies input and core circuitry.
6, 19, 30, 43	VEE	Ground

Pin Characteristics

Symbol	Description	Min.	Typ.	Max.	Units
C _{IN}	Input Capacitance		4		pF
R _{PULLUP}	Input Pull Up Resistor		50		K Ω
R _{PULLDOWN}	Input Pull Down Resistor		30		K Ω

Clock Input Function Table

Inputs		Outputs		Input to Output Mode	Polarity
CLK	/CLK	Qx	/Qx		
0	1	Low	High	Differential to Differential	Non-Inverting
1	0	High	Low	Differential to Differential	Non-Inverting
0	Biased ⁽¹⁾	Low	High	Single-Ended to Differential	Non-Inverting
1	Biased ⁽¹⁾	High	Low	Single-Ended to Differential	Non-Inverting
Biased ⁽¹⁾	0	High	Low	Single-Ended to Differential	Inverting
Biased ⁽¹⁾	1	Low	High	Single-Ended to Differential	Inverting

Note:

1. Refer to Interface Applications for Single-Ended Interfaces.

Absolute Maximum Ratings⁽¹⁾

Supply Voltage (V_{CC})	4.6V
Input Voltage (V_{IN})	-0.5V to $V_{CC} + 0.5V$
LVPECL Output Current (I_{OUT})	
Continuous	50mA
Surge	100mA
Lead Temperature (soldering, 20sec.)	260°C
Storage Temperature (T_s)	-65°C to +150°C

Operating Ratings⁽²⁾

Supply Voltage (V_{CC})	3.135V to 3.465V
Output Supply Voltage (V_{CCO})	2.375V to 2.625V
Ambient Temperature (T_A)	0°C to +70°C
Package Thermal Resistance ⁽³⁾	
TQFP	
Still-air (θ_{JA})	48°C/W
Junction-to-Case (θ_{JC})	25°C/W

DC Electrical Characteristics⁽⁶⁾

$V_{CC} = 3.135V$ to $3.465V$, $V_{CCO} = 2.375V$ to $2.625V$, $T_A = 0^\circ C$ to $+70^\circ C$, unless otherwise stated.

Symbol	Parameter	Condition	Min.	Typ.	Max.	Units
V_{CC}	Power Supply Voltage Range		3.135	3.3	3.465	V
V_{CCO}	Output Power Supply		2.375	2.5	2.625	
I_{EE}	Power Supply Current	Max. V_{CC} , V_{CCO}			125	mA
I_{IH}	Input HIGH Current	CLK	$V_{CC} = V_{IN} = 3.465V$		150	uA
		/CLK			5	uA
I_{IL}	Input LOW Current	CLK	$V_{CC} = 3.465V$, $V_{IN} = 0.5V$	-5		uA
		/CLK		-150		uA
V_{PP}	Peak-to-Peak Input Swing		0.15		1.3	V
V_{CMR}	Common Mode Input Voltage	Note 4, 5	0.5		$V_{CC} - 0.85$	V

PECL Outputs DC Electrical Characteristics⁽⁶⁾

$V_{CC} = 3.135V$ to $3.465V$, $V_{CCO} = 2.375V$ to $2.625V$, $T_A = 0^\circ C$ to $+70^\circ C$, Outputs terminated with 50Ω to $V_{CCO} - 2V$ unless otherwise stated.

Symbol	Parameter	Condition	Min.	Typ.	Max.	Units
V_{OH}	Output HIGH Voltage		$V_{CCO} - 1.1$		$V_{CCO} - 0.7$	V
V_{OL}	Output LOW Voltage		$V_{CCO} - 2.0$		$V_{CCO} - 1.4$	V
V_{OUT}	Output Voltage Swing		0.55		0.93	V

Notes:

1. Permanent device damage may occur if absolute maximum ratings are exceeded. This is a stress rating only and functional operation is not implied at conditions other than those detailed in the operational sections of this data sheet. Exposure to absolute maximum ratings conditions for extended periods may affect device reliability.
2. The data sheet limits are not guaranteed if the device is operated beyond the operating ratings.
3. Package thermal resistance assumes exposed pad is soldered (or equivalent) to the device's most negative potential on the PCB. ψ_{JB} and θ_{JA} values are determined for a 4-layer board in still-air number, unless otherwise stated. The circuit is designed to meet the DC specifications shown in the above table after thermal equilibrium has been established.
4. For single-ended applications, the maximum input voltage for CLK, /CLK is $V_{CC} + 0.3V$.
5. Common mode voltage is defined as V_{IH} .
6. The circuit is designed to meet the DC specifications shown in the above table after thermal equilibrium has been established.

AC Electrical Characteristics

$V_{CC} = 3.135V$ to $3.465V$, $V_{CCO} = 2.375V$ to $2.625V$, $T_A = 0^{\circ}C$ to $+70^{\circ}C$, unless otherwise stated.

Symbol	Parameter	Condition	Min.	Typ.	Max.	Units
f_{MAX}	Maximum Frequency		500			MHz
t_{PD}	Propagation Delay	Note 7	1		2	ns
t_{Skew}	Output-to-Output skew	Note 8, 10		26	50	ps
	Part-to-Part Skew	Notes 9, 10			250	ps
t_{JITTER}	Integration Range = 12kHz – 20MHz	Output = 312MHz		477		fs
t_R, t_F	Output Rise/Fall Times (20% to 80%)	At full output swing.	300		700	ps
	Duty Cycle		47	50	53	%

Notes:

7. Measured from the differential input crossing point to the differential output crossing point.
8. Output-to-Output skew is the difference in time between outputs, receiving data from the same input, for the same temperature, voltage and transition.
9. Part-to-part skew is defined for two parts with identical power supply voltages at the same temperature and no skew at the edges at the respective inputs.
10. This parameter is defined in accordance with JEDEC Standard 65.

Phase Noise Graph

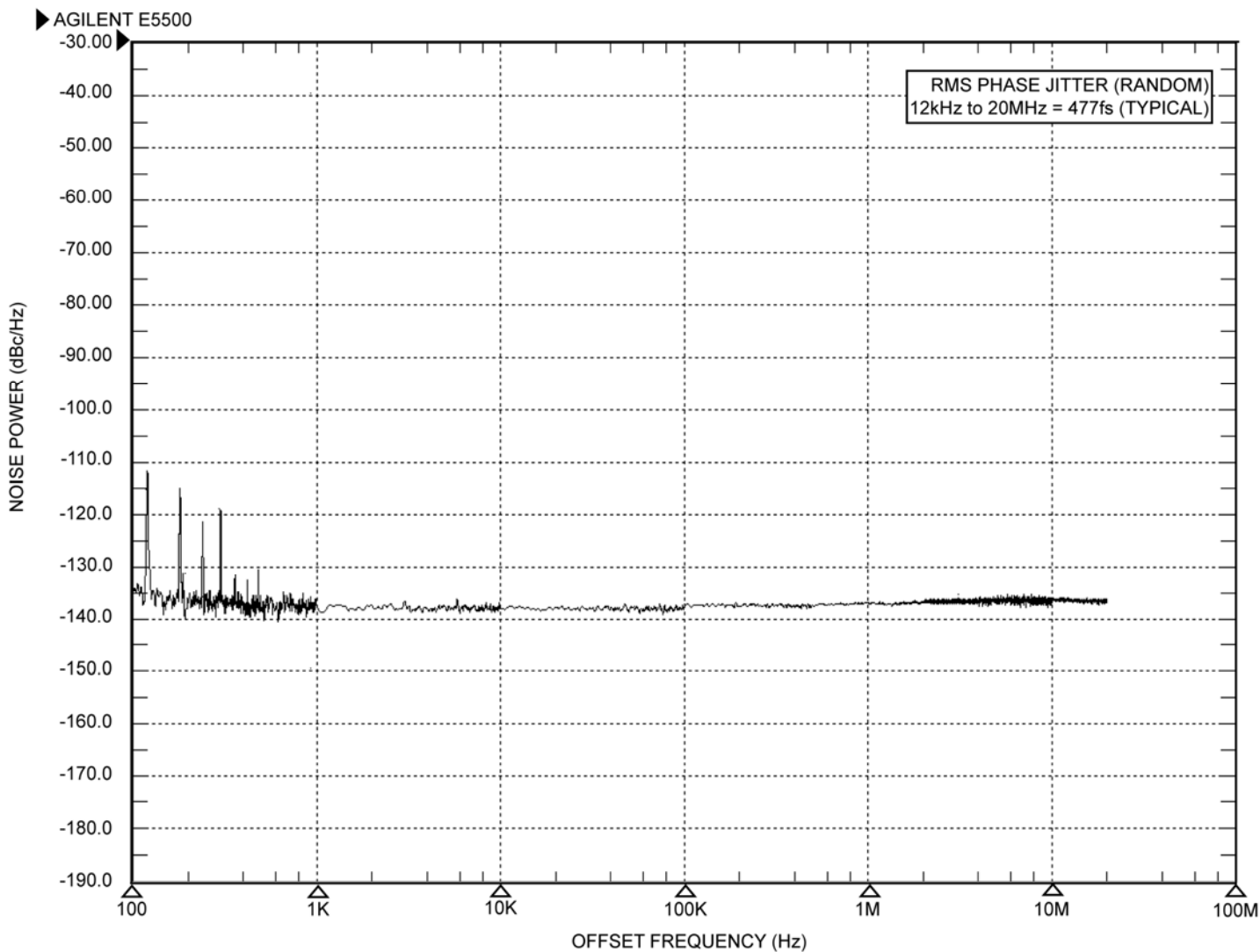

Phase Noise Plot: 312MHz @ 3.3V

Test Circuit

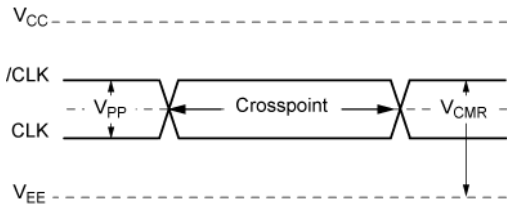

Differential Input Level

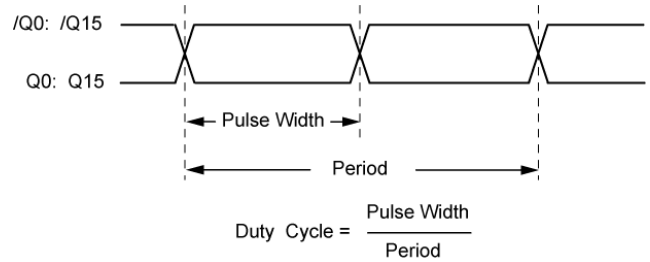

Output Duty Cycle

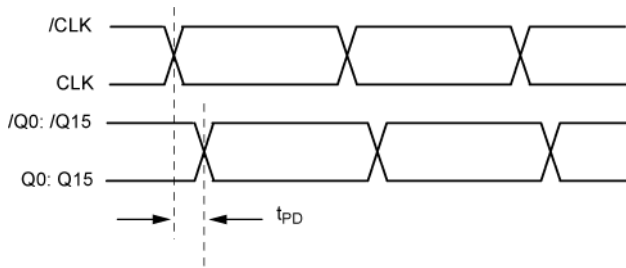

Propagation Delay

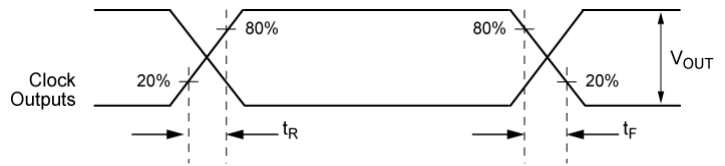

Output Rise/Fall Times

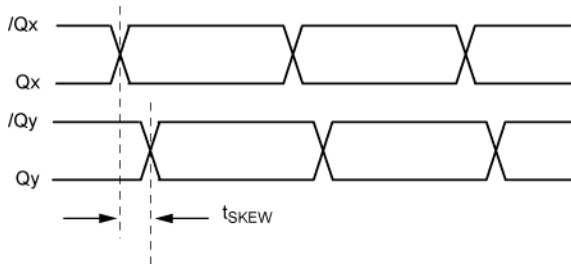

Output-to-Output Skew

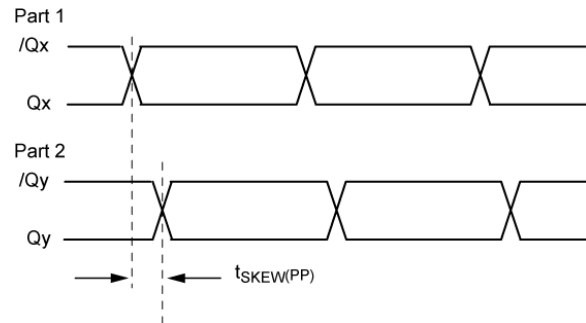

Part-to-Part Skew

Typical Characteristics

$V_{CC} = 3.3V$, $V_{CCO} = 2.5V$, $T_A = 25^\circ C$, Input Signal = 800mV

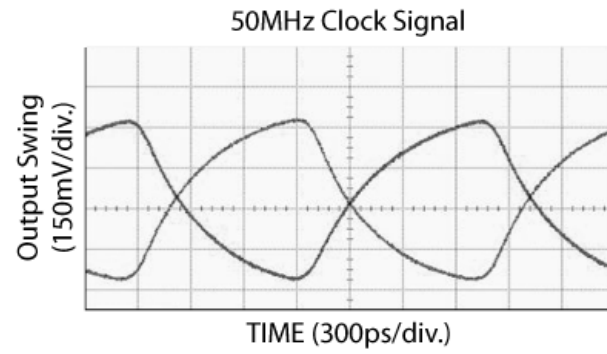
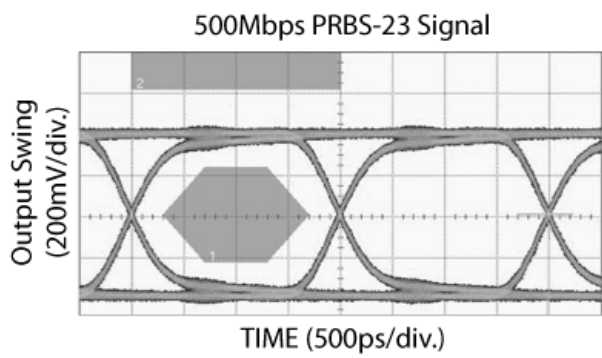

Output Interface Applications

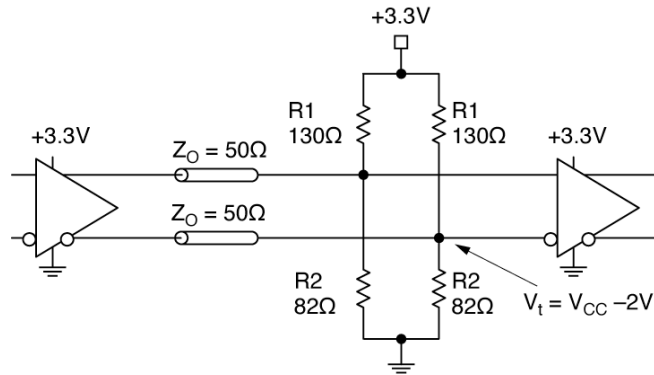

Figure 1. Parallel Termination-Thevenin Equivalent

Notes:

1. For +2.5V systems: $R_1 = 250\Omega$, $R_2 = 82.5\Omega$.
2. For +5.0V systems: $R_1 = 82\Omega$, $R_2 = 130\Omega$.

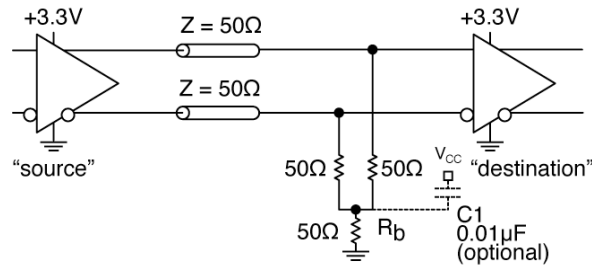

Figure 2. Three-Resistor "Y-Termination"

Notes:

1. Power-saving alternatives to Thevenin termination.
2. Place termination resistors as close to destination inputs as possible.
3. R_b resistor sets the DC bias voltage, equal to V_t . For +3.3V systems $R_b = 46\Omega$ to 50Ω . For +5V systems, $R_b = 110\Omega$.

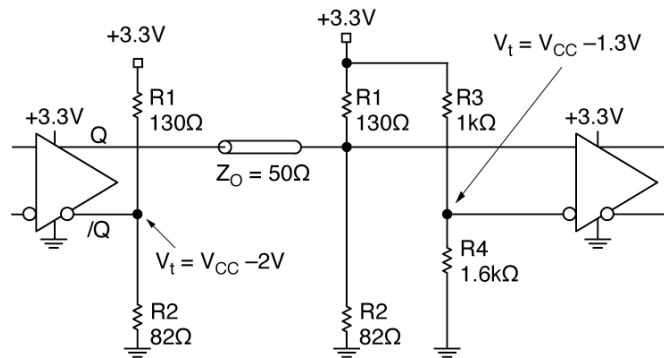

Figure 3. Terminating Unused I/O

Notes:

1. Unused output (/Q) must be terminated to balance the output.
2. For 2.5V systems: $R_1 = 250\Omega$, $R_2 = 62.5\Omega$, $R_3 = 1.25k\Omega$, $R_4 = 1.2k\Omega$.

Input Interface Applications

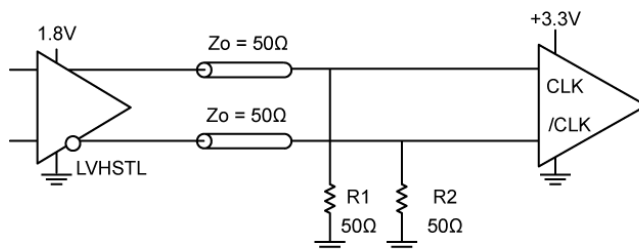

Figure 4. CLK and /CLK Input Driven By 1.8V LVHSTL

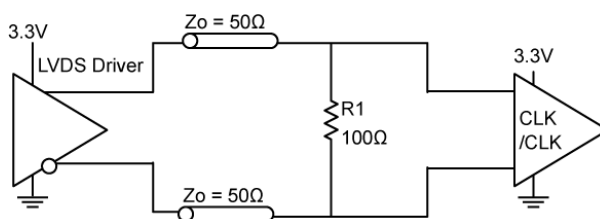

Figure 5. CLK and /CLK Input Driven By 3.3V LVDS Driver

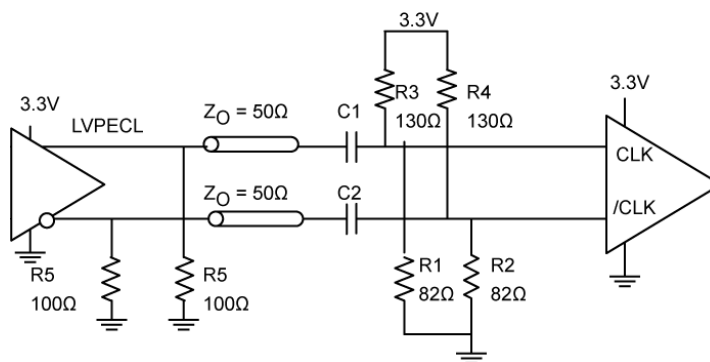
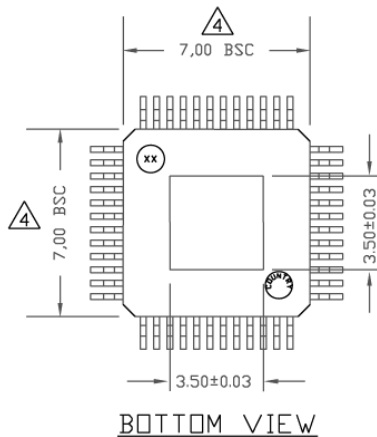
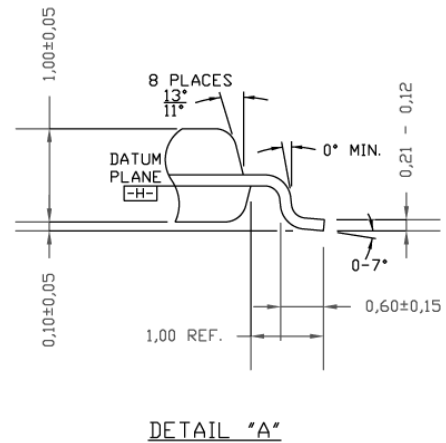
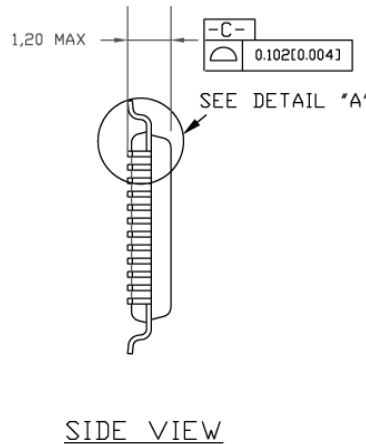
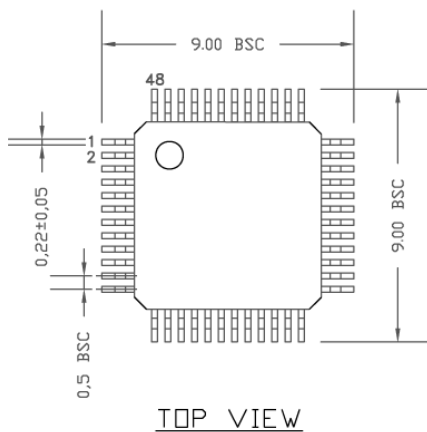

Figure 6. CLK and /CLK Input Driven By 3.3V LVPECL Driver with AC Couple

Notes:

1. For +2.5V systems: R_1 & $R_2 = 250\Omega$, R_3 & $R_4 = 82.5\Omega$.
2. For +5.0V systems: R_1 & $R_2 = 82\Omega$, R_3 & $R_4 = 130\Omega$.

Package Information



NOTES:

1. DIMENSION DOES NOT INCLUDE MOLD FLASH OR PROTRUSIONS, EITHER OF WHICH SHALL NOT EXCEED 0.254MM.
 2. LEAD DIMENSION DOES NOT INCLUDE DAMBAR PROTRUSION.
 3. PACKAGE TOP MOLD DIMENSIONS ARE SMALLER THAN BOTTOM
-  MOLD DIMENSIONS AND TOP OF PACKAGE WILL NOT OVERHANG BOTTOM OF PACKAGE.

48-Pin TQFP (TQFP-48)

MICREL, INC. 2180 FORTUNE DRIVE SAN JOSE, CA 95131 USA
 TEL +1 (408) 944-0800 FAX +1 (408) 474-1000 WEB <http://www.micrel.com>

Micrel makes no representations or warranties with respect to the accuracy or completeness of the information furnished in this data sheet. This information is not intended as a warranty and Micrel does not assume responsibility for its use. Micrel reserves the right to change circuitry, specifications and descriptions at any time without notice. No license, whether express, implied, arising by estoppel or otherwise, to any intellectual property rights is granted by this document. Except as provided in Micrel's terms and conditions of sale for such products, Micrel assumes no liability whatsoever, and Micrel disclaims any express or implied warranty relating to the sale and/or use of Micrel products including liability or warranties relating to fitness for a particular purpose, merchantability, or infringement of any patent, copyright or other intellectual property right.

Micrel Products are not designed or authorized for use as components in life support appliances, devices or systems where malfunction of a product can reasonably be expected to result in personal injury. Life support devices or systems are devices or systems that (a) are intended for surgical implant into the body or (b) support or sustain life, and whose failure to perform can be reasonably expected to result in a significant injury to the user. A Purchaser's use or sale of Micrel Products for use in life support appliances, devices or systems is a Purchaser's own risk and Purchaser agrees to fully indemnify Micrel for any damages resulting from such use or sale.

© 2009 Micrel, Incorporated.

Компания «Life Electronics» занимается поставками электронных компонентов импортного и отечественного производства от производителей и со складов крупных дистрибьюторов Европы, Америки и Азии.

С конца 2013 года компания активно расширяет линейку поставок компонентов по направлению коаксиальный кабель, кварцевые генераторы и конденсаторы (керамические, пленочные, электролитические), за счёт заключения дистрибьюторских договоров

Мы предлагаем:

- Конкуренспособные цены и скидки постоянным клиентам.
- Специальные условия для постоянных клиентов.
- Подбор аналогов.
- Поставку компонентов в любых объемах, удовлетворяющих вашим потребностям.
- Приемлемые сроки поставки, возможна ускоренная поставка.
- Доставку товара в любую точку России и стран СНГ.
- Комплексную поставку.
- Работу по проектам и поставку образцов.
- Формирование склада под заказчика.
- Сертификаты соответствия на поставляемую продукцию (по желанию клиента).
- Тестирование поставляемой продукции.
- Поставку компонентов, требующих военную и космическую приемку.
- Входной контроль качества.
- Наличие сертификата ISO.

В составе нашей компании организован Конструкторский отдел, призванный помогать разработчикам, и инженерам.

Конструкторский отдел помогает осуществить:

- Регистрацию проекта у производителя компонентов.
- Техническую поддержку проекта.
- Защиту от снятия компонента с производства.
- Оценку стоимости проекта по компонентам.
- Изготовление тестовой платы монтаж и пусконаладочные работы.



Тел: +7 (812) 336 43 04 (многоканальный)

Email: org@lifeelectronics.ru